

# RF AMPLIFIER REPLACEMENT (FROM ANALOGIC TO TELI)

## TABLE OF CONTENTS

Table of Contents .....	1
1.Overview .....	2
1-1.Required Tool.....	2
2.Lock Out Tag Out .....	3
3.REMOVAL / REPLACEMENT OF RF AMPLIFIER POWER MODULE.....	4
3-1.RF Amplifier Power Module Replacement .....	5
4.Restoration .....	10
APPENDIX A- UNIVERSAL LIFT KIT ASSEMBLY FOR 0.35T POWER CABINET .....	11

Rev 1

**1. Overview**

This Service Note describes replacement procedure from Analogic RF Amp to Teli RF Amp. Refer to *Appendix A- Universal Lift Kit Assembly* procedure for instructions on using hoist to lift RF Amplifier Power Module into the 0.35T Power Cabinet.

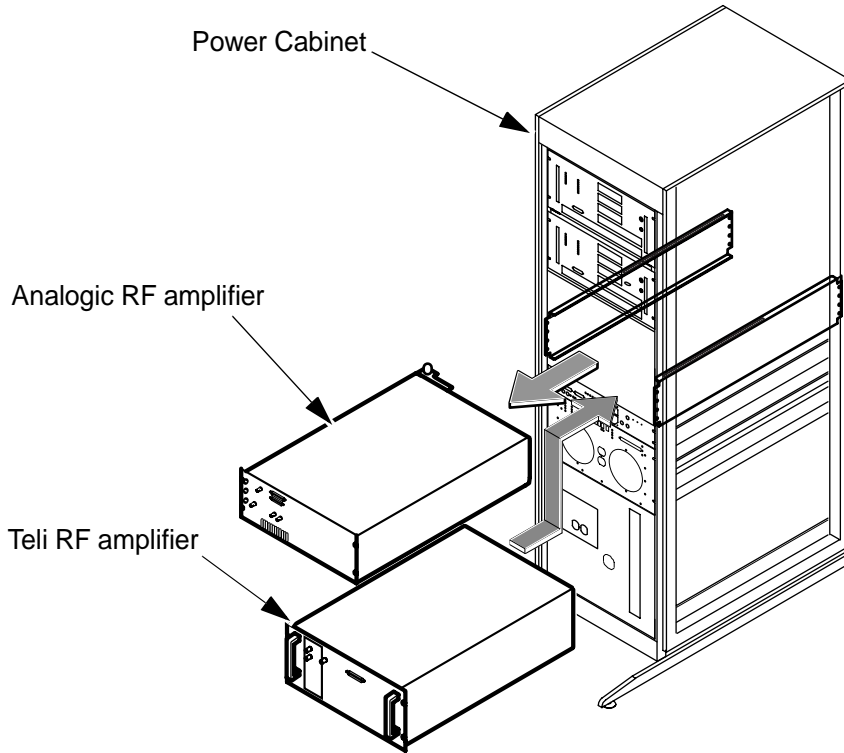

**RF AMPLIFIER**

**FRU (1) PART LIST**

<b>Manufacturer's Part Number</b>	<b>GEMS Part Number</b>	<b>Item Description</b>
TGA1406A	2320323	RF Amplifier Module with Case

**1-1 Required Tool:**

Items	Qty	Type/Parts Number	Part
Lock and Tag (for Lock Out Tag Out)	1		
Digital Multimeter	1		
Phillips Screwdriver	1		
Standard Screwdriver	1	2326630	Cable connecting of rear panel
Two medium sized crescent wrenches	1		

Rev 1

## 2. LOCK OUT TAG OUT



**FATAL ELECTRIC SHOCK HAZARD! TO PREVENT FATAL ELECTRIC SHOCK, DISCONNECT POWER AT THE PDU BEFORE YOU PERFORM THE REMOVAL/REPLACEMENT PROCEDURES. PERFORM LOCKOUT TAGOUT PROCEDURE. DO THIS BY SECURING THE PDU MAIN INPUT CIRCUIT BREAKER.**

1. Bring Signa software down.
2. Remove the front, rear and side covers from the 0.35T Power Cabinet.
3. Turn OFF the "OC/HOST" circuit breaker at the Power Distribution Unit (PDU).
4. Turn OFF the "SSM" circuit breaker at the Power Distribution Unit (PDU).
5. At the front (left) of the PDU place the "MAIN INPUT CIRCUIT BREAKER" switch to the OFF position.
6. Lock Out Tag Out the PDUs "MAIN INPUT CIRCUIT BREAKER" (press the light gray arrow on the handle and insert the lock and tag).
7. Verify all LEDs are OFF (not illuminated) on front of SSM, RFI.
8. Using a Voltmeter measure the RF Amplifier Power Module input power located in the rear (right) of the 0.35T Power Cabinet.
  - Measure between L1 and L2, verify voltmeter measures 0 VAC.

Rev 1

**3. REMOVAL / REPLACEMENT OF RF AMPLIFIER POWER MODULE**

**WARNING!**

**POSSIBLE PERSONAL INJURY! REMOVE POWER FROM THE PDU MAIN INPUT CIRCUIT BREAKER BEFORE REMOVING RF AMPLIFIER. VERIFY THAT LOCK OUT AND TAG OUT THE PDU MAIN INPUT CIRCUIT BREAKER IS PROPERLY PERFORMED. SERIOUS INJURY OR DEATH BY ELECTROCUTION MAY OTHERWISE OCCUR.**

1. Perform Section 2- Lock Out Tag Out (Refer to CD-ROM *Dir. 2250758-3 [or -2], MR Signa OpenSpeed Service Methods, Renewal Parts and Service Tools, Safety, Section 6, OSHA LOCKOUT/TAGOUT REQUIREMENTS.*)
2. At the rear of the 0.35T Power Cabinet turn OFF the CB1, CB2, CB3, and CB4 circuit breakers on the rear of the System Support Module (SSM). Remove the humboldt connector (P1) on rear of SSM. See Illustration 1.

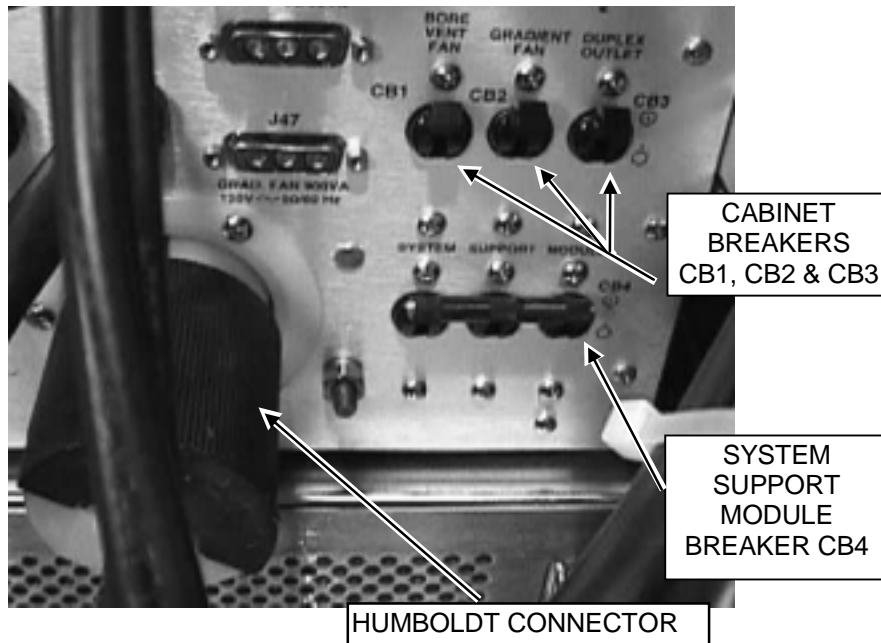

**REAR CABINET CIRCUIT BREAKER LOCATIONS  
ILLUSTRATION 1**

Rev 1

**3-1 RF Amplifier Power Module Replacement (continued)**

3. Visually verify that power has been removed by verifying the fans and LEDs on the RFI, RF Amp, and SSM (System Support Module) are OFF.
4. Disconnect all connectors from front and rear panel of Analogic RF amplifier.
  - Front Panel: J4 (RF Out), J1 (Customer Interface) and J3 (RF In)
  - Rear Panel: L1(BLK), L2(RED) and Ground cable
5. Remove 4 screws from front panel of RF amplifier.
6. Withdraw RF amplifier until lock point of guide rail.
7. Release the lock pin of RF amplifier from upper side of guide rail.
8. Remove RF amplifier from the power cabinet.

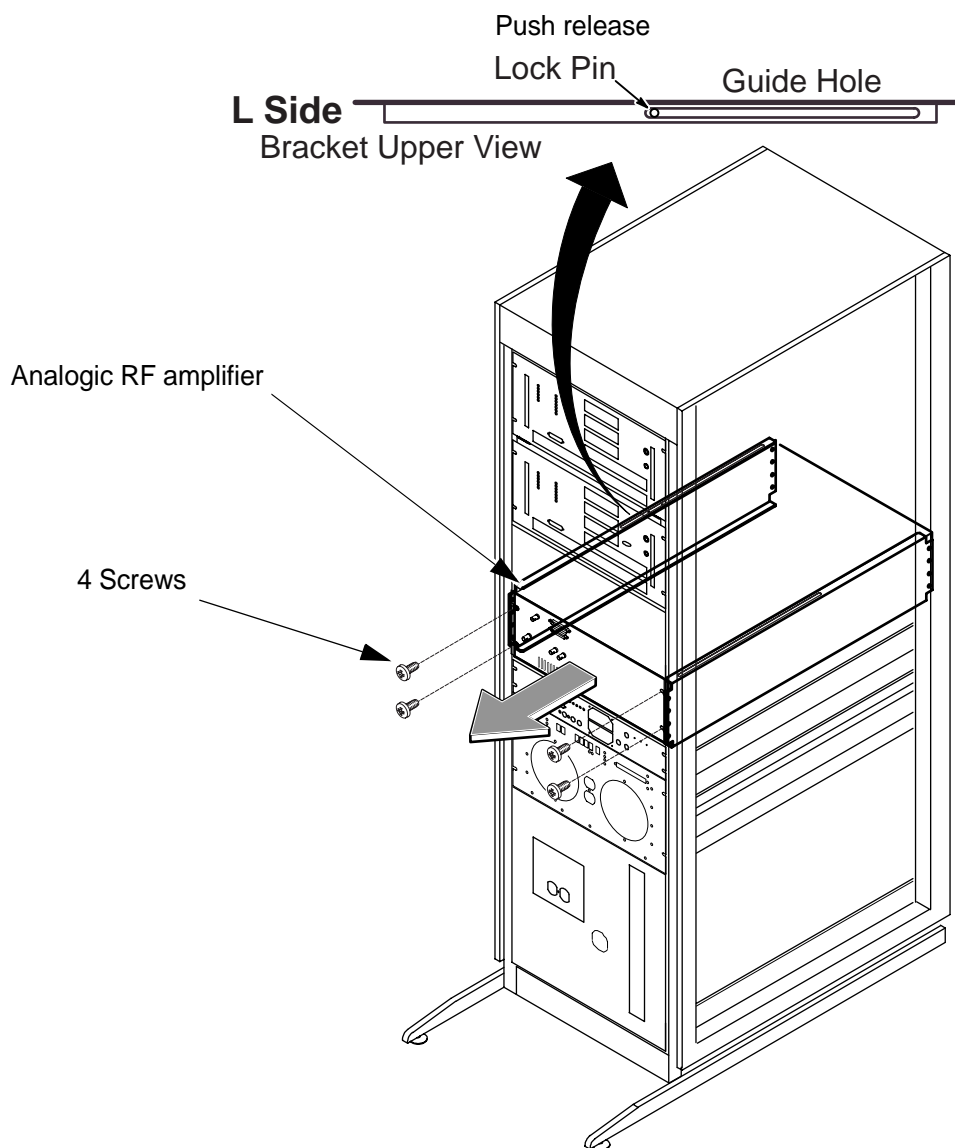

**RF AMPLIFIER POWER MODULE REPLACEMENT  
ILLUSTRATION 2**

Rev 1

**3-1 RF Amplifier Power Module Replacement (continued)**

- 9. Remove R and L guide rails from the power cabinet by removing 6 screws for each side.
- 10. Install R and L guide rails to the power cabinet with 8 screws and clips for each side.

**NOTE: Direct the guide hole of L guide rail to rear side.**

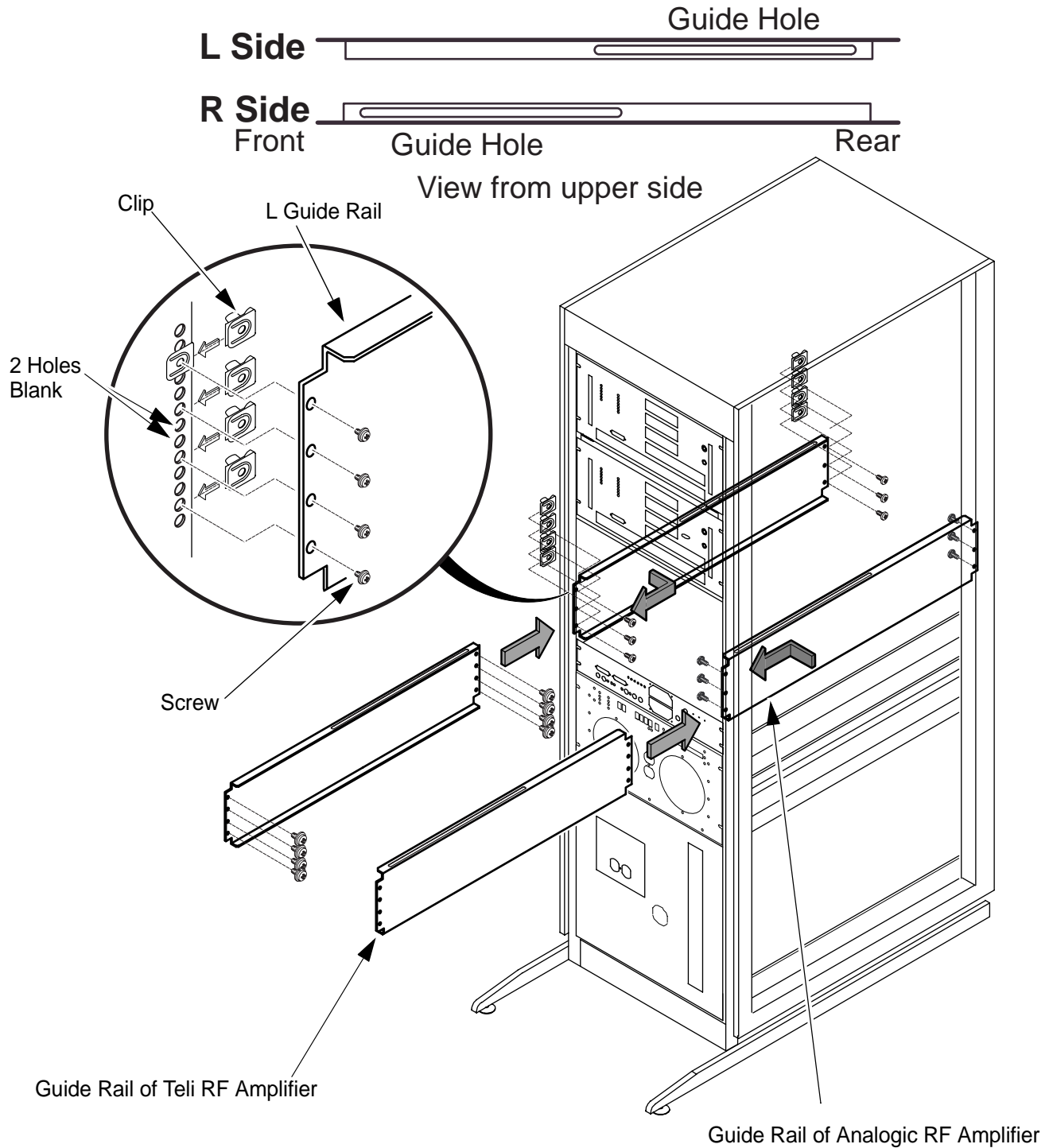

**RF AMPLIFIER POWER MODULE REPLACEMENT  
ILLUSTRATION 3**

Rev 1

**3-1 RF Amplifier Power Module Replacement (continued)**

11. Install guide bracket to Teli RF Amp with removed 2 screws.

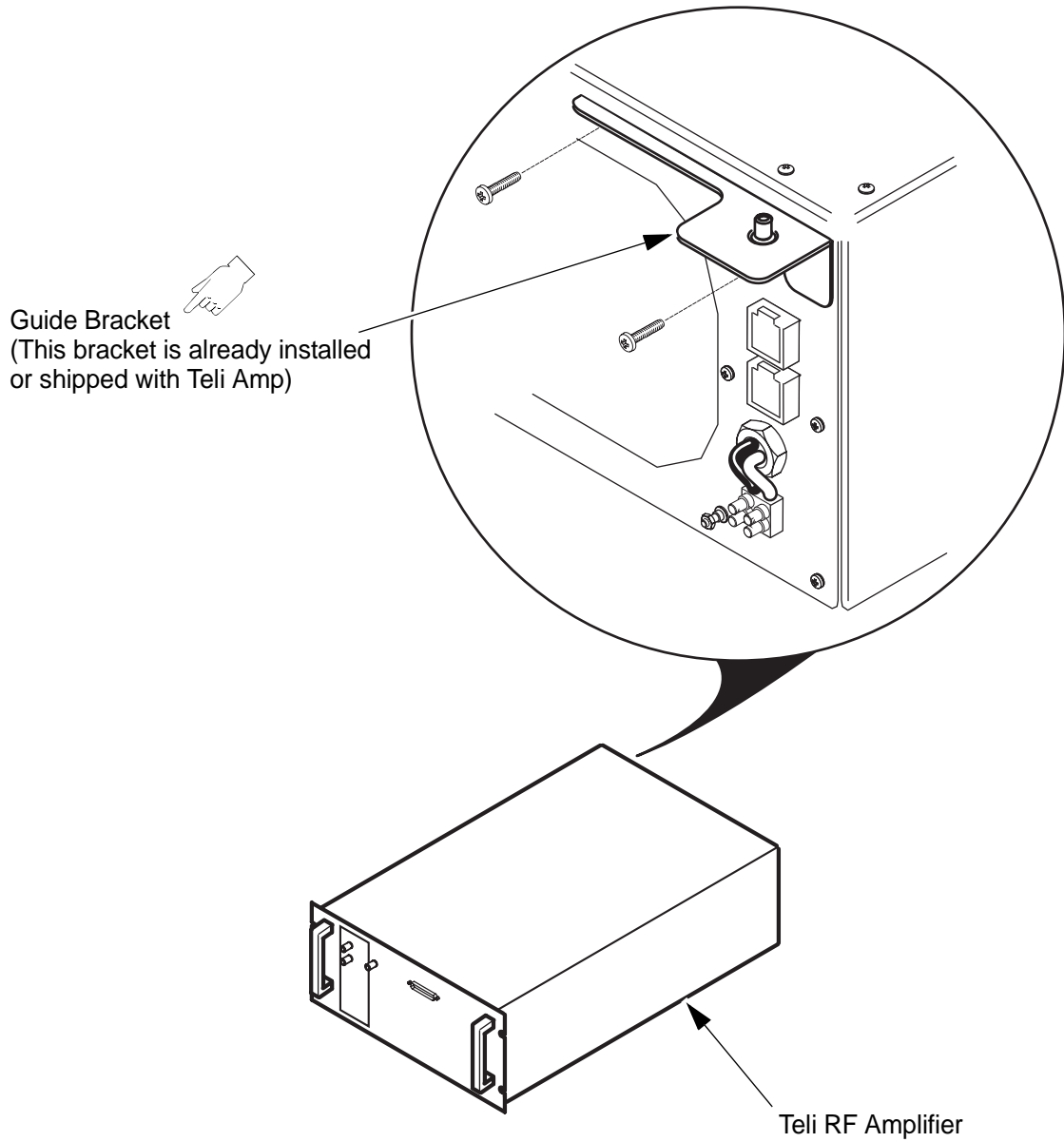

**RF AMPLIFIER POWER MODULE REPLACEMENT  
ILLUSTRATION 4**

Rev 1

**3-1 RF Amplifier Power Module Replacement (continued)**

- 12. Install Teli RF Amp to the power cabinet holding pin of guide bracket.
- 13. Fix front panel of RF Amp to the power cabinet with 4 screws.

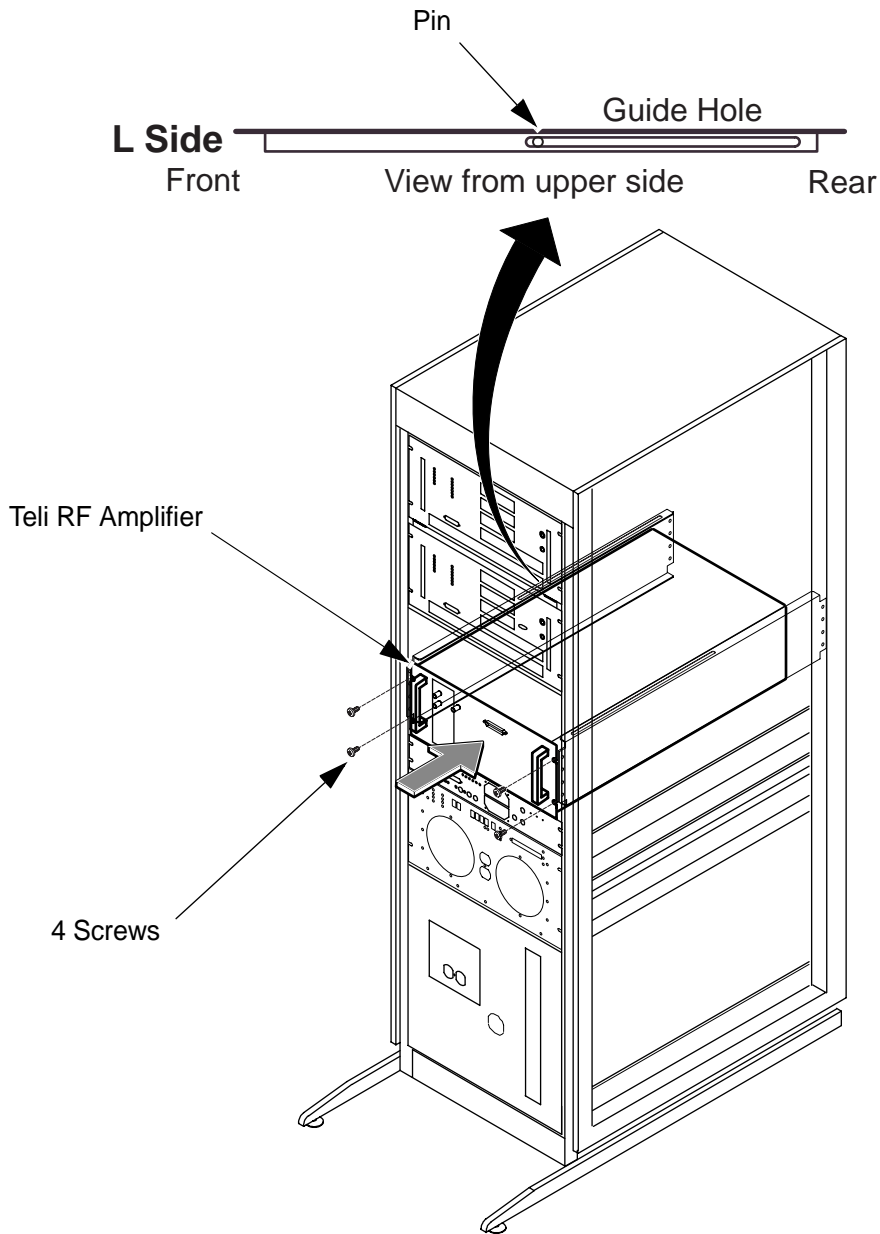

**RF AMPLIFIER POWER MODULE REPLACEMENT  
ILLUSTRATION 5**

Rev 1

**3-1 RF Amplifier Power Module Replacement (continued)**

14. Connect the cables to front and rear side of RF Amp as illustration.

- Teli RF Amp (Front side) RF IN J3 - AMP1 Drive
- Teli RF Amp (Front side) Ext Cont J1 - RF Interface AMP 1 COMM J16
- Teli RF Amp (Rear side) RF OUT J4 - RF Interface AMP 1 IN J1
- Teli RF Amp (Rear side) L1, L2 and Ground

15. Fix the cable to right handle of RF amplifier with tie-wrap.

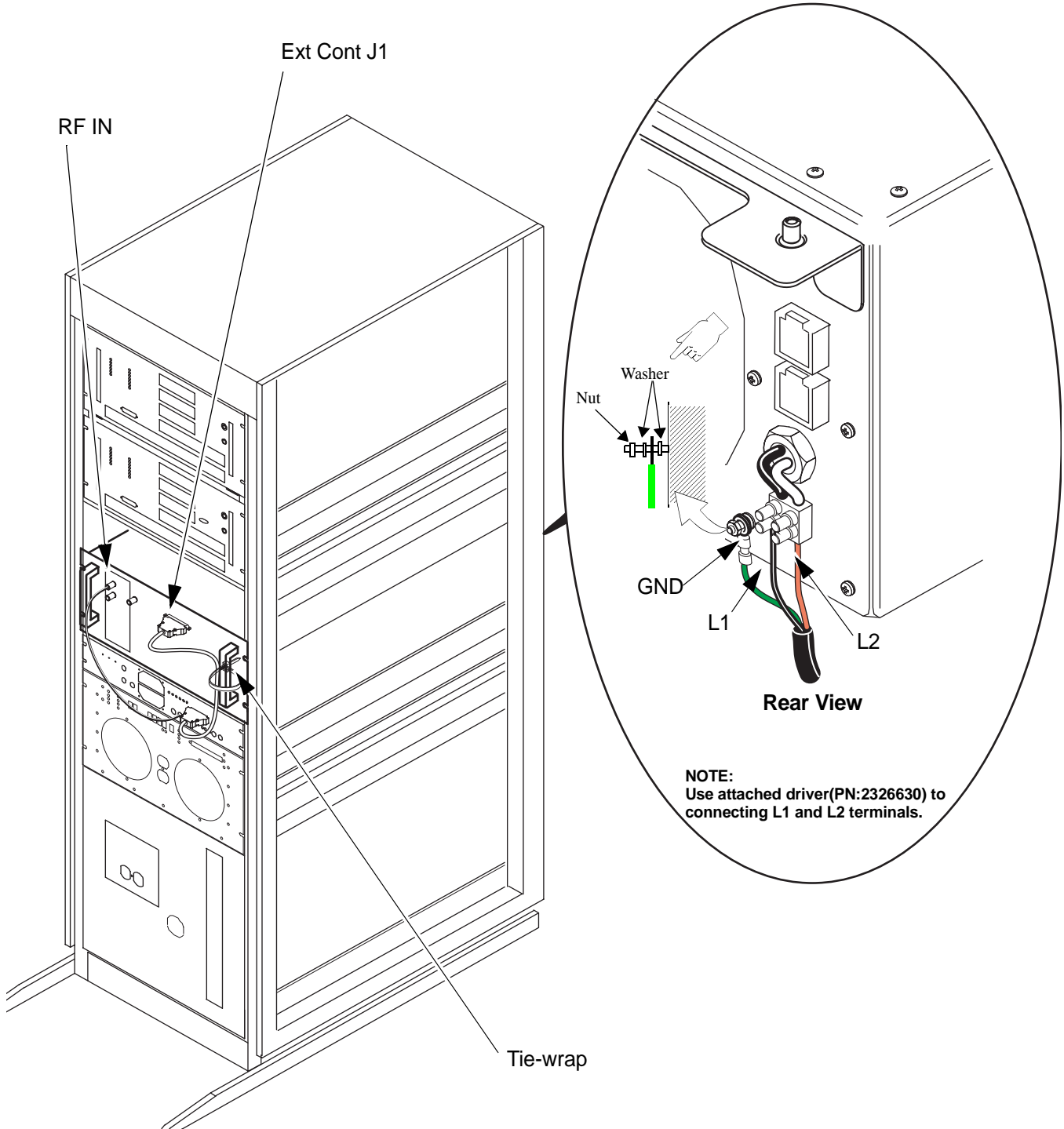

**RF AMPLIFIER POWER MODULE REPLACEMENT  
ILLUSTRATION 6**

Rev 1

#### 4. Restoration

1. Visually verify the "MAIN INPUT CIRCUIT BREAKER" switch is in the OFF position at the front (left) of the PDU and has the proper Lock Out Tag Out before continuing.
2. Remove lock and tag out from the PDU "MAIN INPUT CIRCUIT BREAKER" and restore power to the 0.35T Power Cabinet.
  - A. Re-connect the SSM humboldt connector (P1).
  - B. Place the four (4) circuit breakers located at the rear of the "SSM" to the ON position.
  - C. Switch ON the "SSM" circuit breaker at the front of the PDU.
  - D. Switch ON the "OC/HOST" circuit breaker at the front of the PDU.

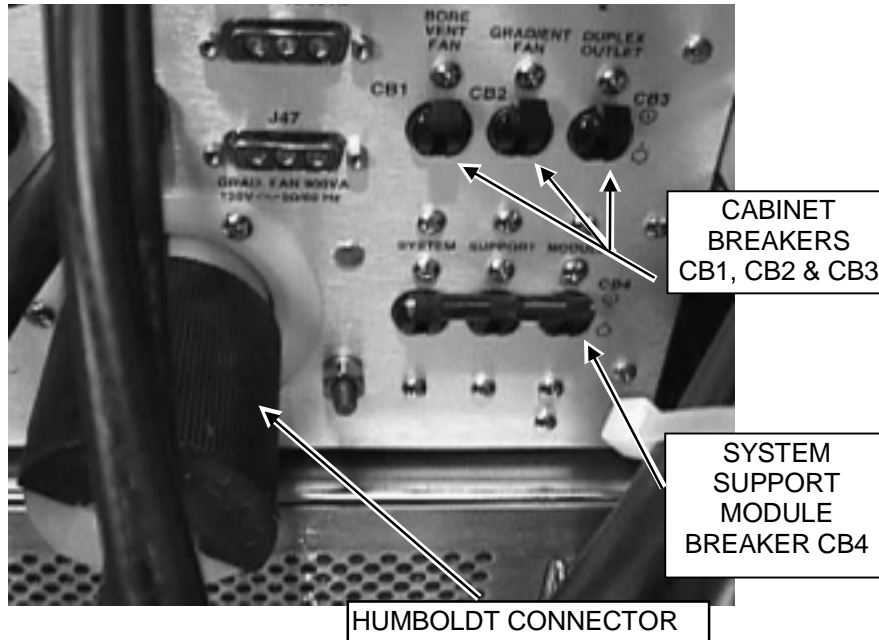

**REAR CABINET CIRCUIT BREAKER LOCATIONS**

3. Verify the RF Amplifier switch is ON at the rear of the RF Amplifier.
  - Re-SIGNA as required.
4. After replacing the RFI Module, the RF Amplifier needs to be calibrated, refer to *GRFD Power RF Out Setup And Calibration* on the CD ROM, Direction 2250758-3 [or -2].
5. Reinstall all covers to 0.35T Power Cabinet.

Rev 1

## APPENDIX A- UNIVERSAL LIFT KIT ASSEMBLY FOR 0.35T POWER CABINET

### A-1 Introduction

The Universal Lift Hoist is assembled from parts stored in the Universal Lift Hoist Kit. Lift attachments specially designed for the RF/PDU Cabinet (1.0T) are found in the outer-most compartments of the lift kit.

### A-2 Tools Required

- Universal Lift Hoist Kit with RF/PDU attachments, 46-317266G5
- Small hand tools including a Phillips-head screwdriver
- Two medium sized crescent wrenches

### A-3 Assembly Procedural Steps

1. Remove the bracket at top of cabinet.
2. Locate the three (3) large Steel Rail sections and place them on a flat surface for assembly. See Illustration A-1.

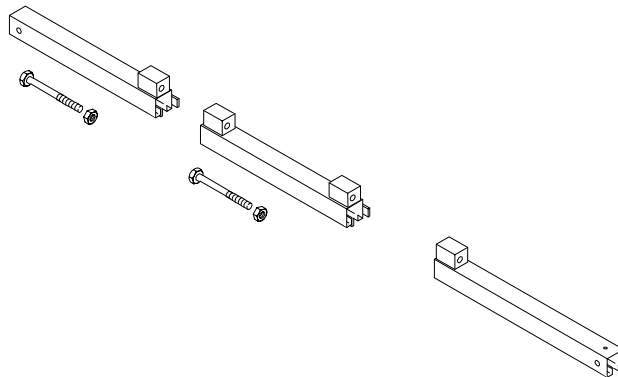

#### STEEL RAIL SECTIONS, HEX BOLTS, AND HEX NUTS

ILLUSTRATION A-1

3. Arrange the rail sections in the proper order (rear, center, then front) and fasten them together with 4.75" X 1/2" caps crews and hex nuts.
4. Use the crescent wrenches to tighten the cap screws.

Rev 1

**A-3 Assembly Procedural Steps (continued)**

5. Locate the Brass Colored Inner Rail and insert it into the Steel Rails as shown in Illustration A-2.

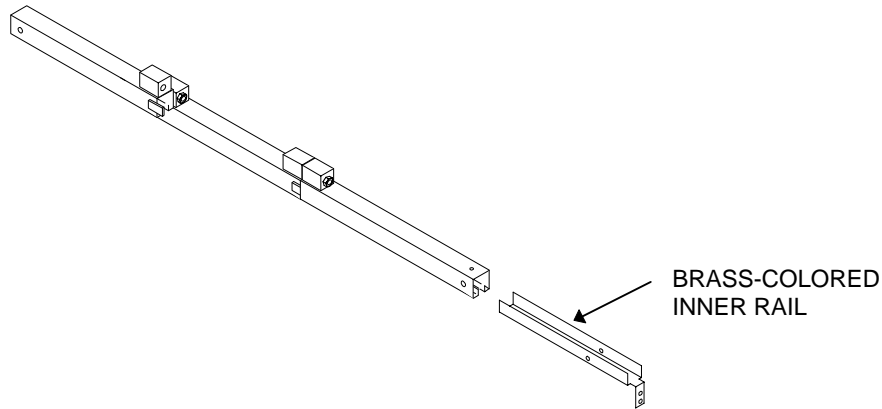

**ASSEMBLED STEEL RAILS AND BRASS-COLORED INNER RAIL**

ILLUSTRATION A-2

6. Insert the Brass Colored Inner Rail into the open end of the rear rail section.
7. Locate one of two (2) locking pins in the lift kit. Insert one locking pin into the hole near the open end of the rear rail section. This locking pin secures the Brass Colored Inner Rail to the outer Steel Rail. See Illustration A-3.

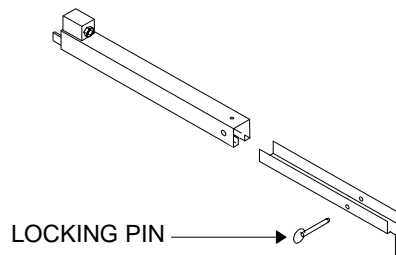

**REAR STEEL RAIL, LOCKING PIN, AND BRASS-COLORED INNER RAIL**

ILLUSTRATION A-3

Rev 1

**A-3 Assembly Procedural Steps (continued)**

8. Assemble and fasten the elevating brackets to the rail assembly. See Illustration A-4.

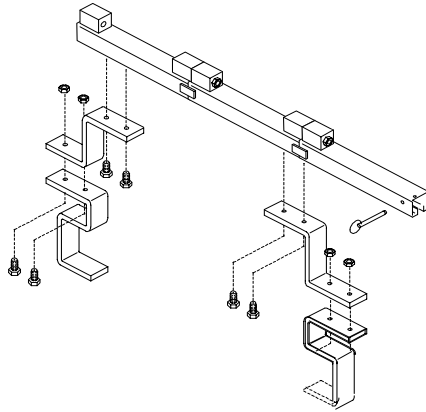

**HOIST TOP RAIL PARTS WITH ELEVATING BRACKETS**

ILLUSTRATION A-4

9. Remove the front and rear covers of the 0.35T Power Cabinet.

Rev 1

**A-3 Assembly Procedural Steps (continued)**

10. Place the Steel Rail and elevating bracket assembly at the top of the 0.35T Power Cabinet. Center the Rail Assembly on the top of the RF Amplifier. See Illustration A-5.

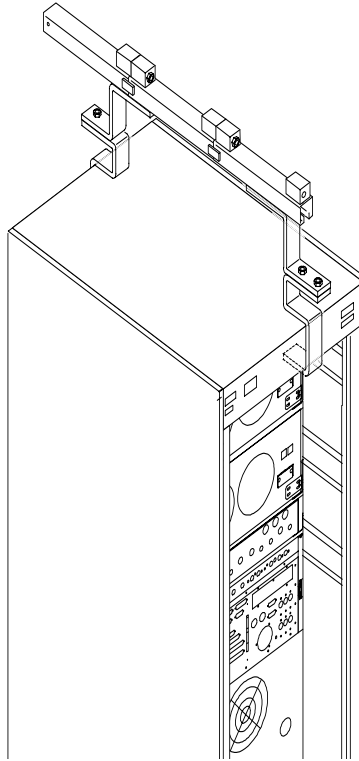

**HOISTPARTS REAR VIEW ASSEMBLED**  
ILLUSTRATION A-5

11. Locate the Hoist Assembly in the Lift Kit. See Illustration A-6.

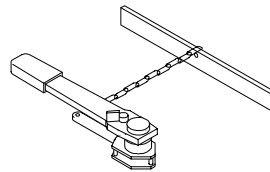

**HOIST ASSEMBLY**  
ILLUSTRATION A-6

Rev 1

**A-3 Assembly Procedural Steps (continued)**

12. Insert the Hoist Assembly into the open end of the front rail. Insert a locking pin into the holes near the front edge of the front rail. This locking pin prevents the Hoist Assembly from sliding out of the rails. See Illustration A-7.

**PLACEMENT OF HOIST ASSEMBLY INTO FRONT END OF STEEL RAIL ASSEMBLY**

ILLUSTRATION A-7

Rev 1

**A-3 Assembly Procedural Steps (continued)**

13. Select the proper lift brackets for the Analogic RF Amplifier and attach to side of amplifier, then attach the Hoist Assembly to the lift bracket. See Illustration A-8.

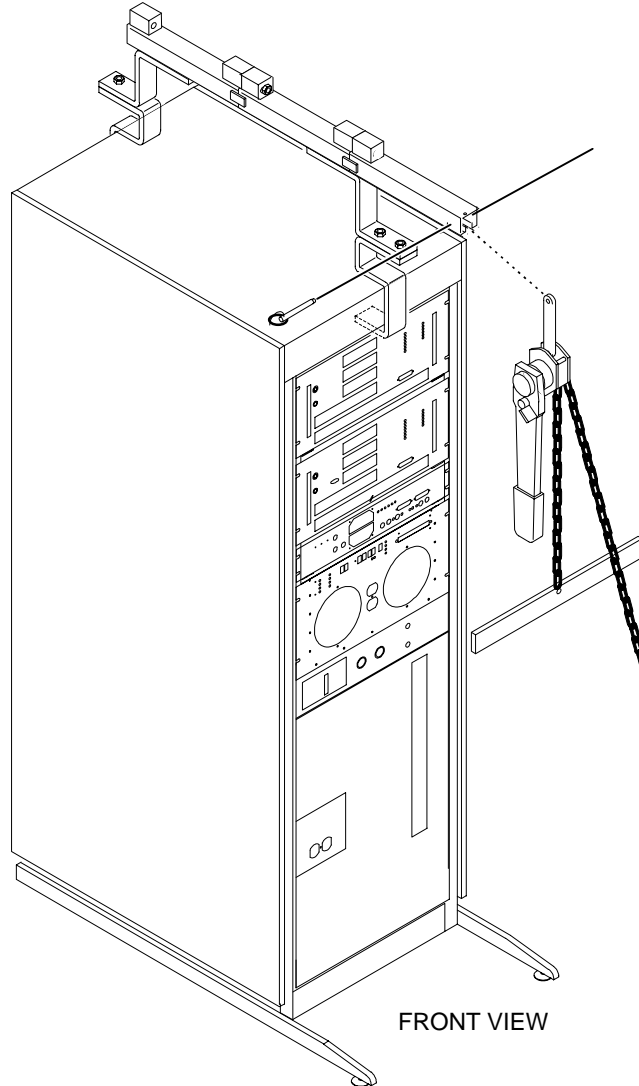
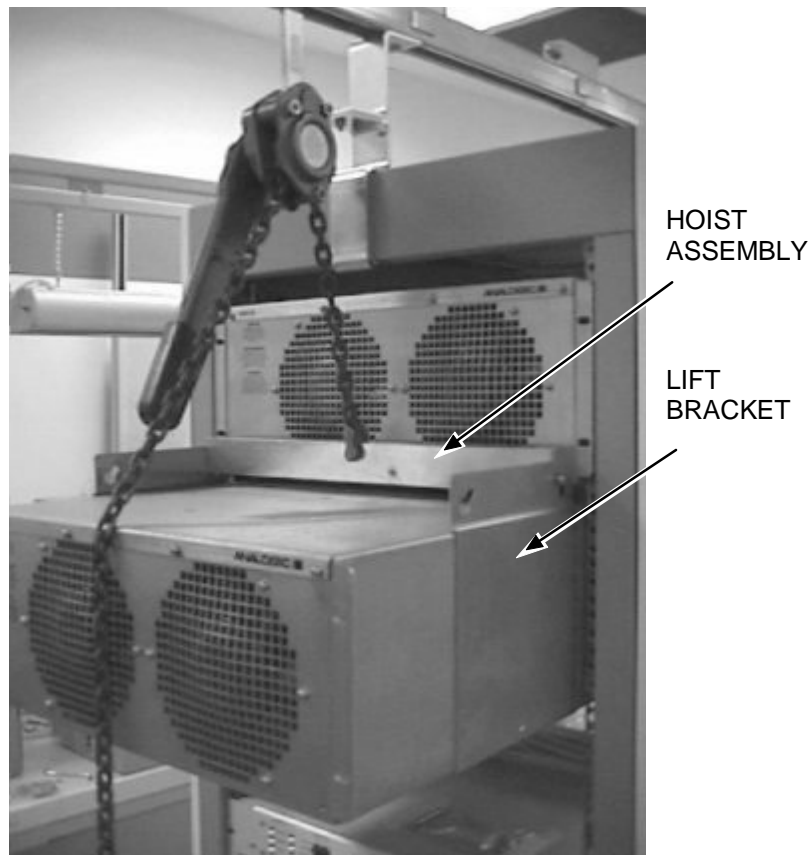

**ATTACHING LIFT BRACKET TO HOIST ASSEMBLY**

ILLUSTRATION A-8

Rev 1

**A-3 Assembly Procedural Steps (continued)**

14. The Universal Lift Hoist is now ready for operation. Illustration A-9 shows the Universal Lift Hoist being used to remove a RF Amplifier Module from a 0.35T Power Cabinet.



**USING THE UNIVERSAL LIFT HOIST TO REMOVE THE RF AMP**

ILLUSTRATION A-9

Rev 1

**Revision History**

<b>Rev</b>	<b>Date</b>	<b>Author</b>	<b>Primary Reasons For Change</b>
0	Feb 01, 2002	K.Tsumagari	Initial Release
1	Nov 27, 2002	Y. Masumo	P7, P9: Corrected information.