

# FRONT FRAME INSTALLATION

## TABLE OF CONTENTS

Table of Contents .....	1
1.Preparation .....	2
2.Front Lower Frame Installation .....	3
3.Side Lower Frame Installation .....	4
4.Front Upper Frame Installation .....	5
5.Magnet Deck Plates Installation .....	6
6.Front Upper Frame Adjustment .....	9

Rev 0

**1. Preparation**

1. Verify that the following frames are already installed before starting the frame installation.

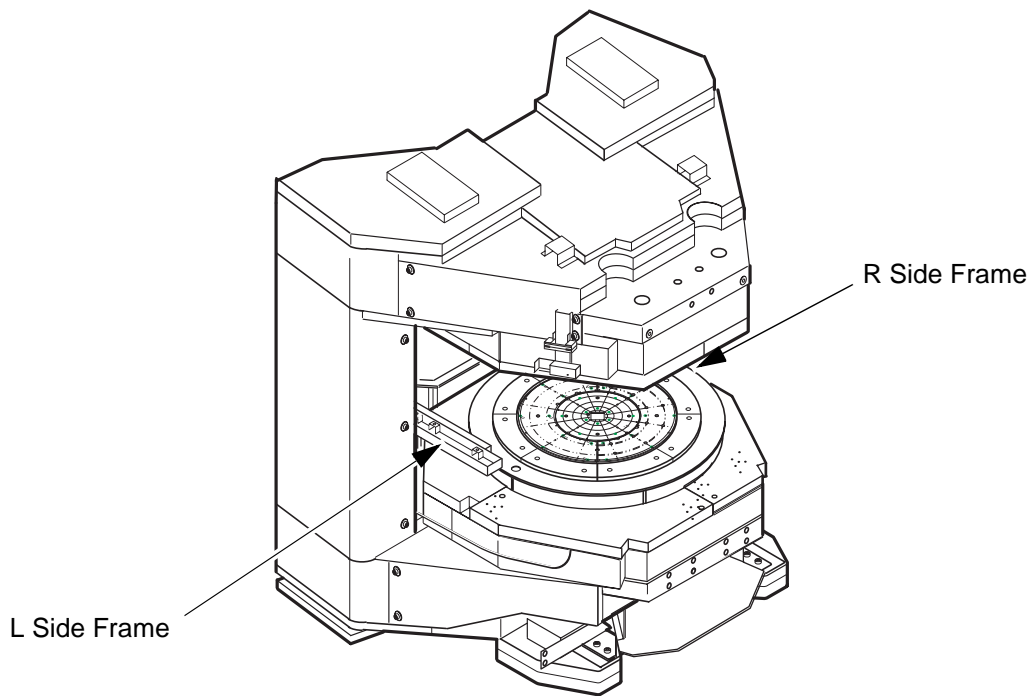

**FRAMES BEFORE STARTING THE INSTALLATION**  
ILLUSTRATION 1

**NOTE:**

The Magnet heater and sensor cables must be routed around the outside of the magnet Insulator. Do not bury the magnet heater and sensor cables into the insulator.

**Required Tool:**

Items	Qty	Type/Parts Number	Part
100 cm Ruler	1	Non ferrous	Front Upper Frame Adjustment
15 cm Ruler	1	Non ferrous	Front Upper Frame Adjustment
Level Gauge	1	Non ferrous	Front Deck Plate Adjustment
Metric Allen Wrench Set	1	Non ferrous	Frame/Insulator Installation

Rev 0

### 2. Front Lower Frame Installation

1. Install Front Lower frame with 4 plastic washers(2281519), 4 washers(N9100WM) and 4 screws(N9020YM: M10).Do not tighten.
2. Install 6 Studs(2145353) and Front Insulators(BORE LF and SIDE FL) to the magnet front lower side.Do not fix insulator with screw/washer.When installing table rail, these insulators will be remove.

**NOTE: Do not fix insulators with screw/washer. When installing table rail, these insulators will be remove.**

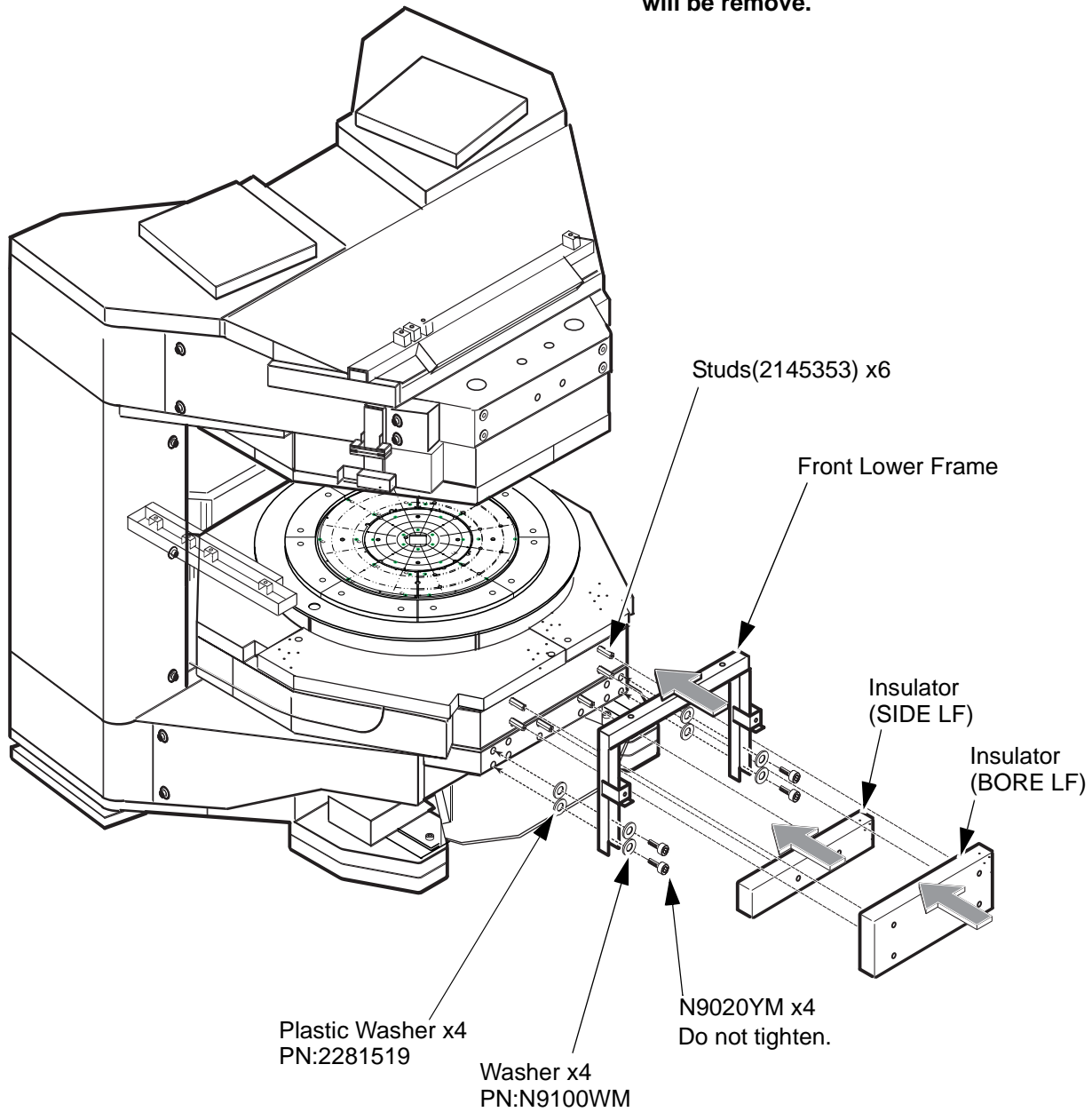

**FRONT LOWER FRAME INSTALLATION  
ILLUSTRATION 2**

Rev 0

### 3. Side Lower Frame Installation

1. Install R and L Side Lower Frames to magnet with 3 shims and 7 screws(U0438AAx4 and U0444AAx3) for each frames.
2. Install 4 Caps to holes of R and L side frames inside.

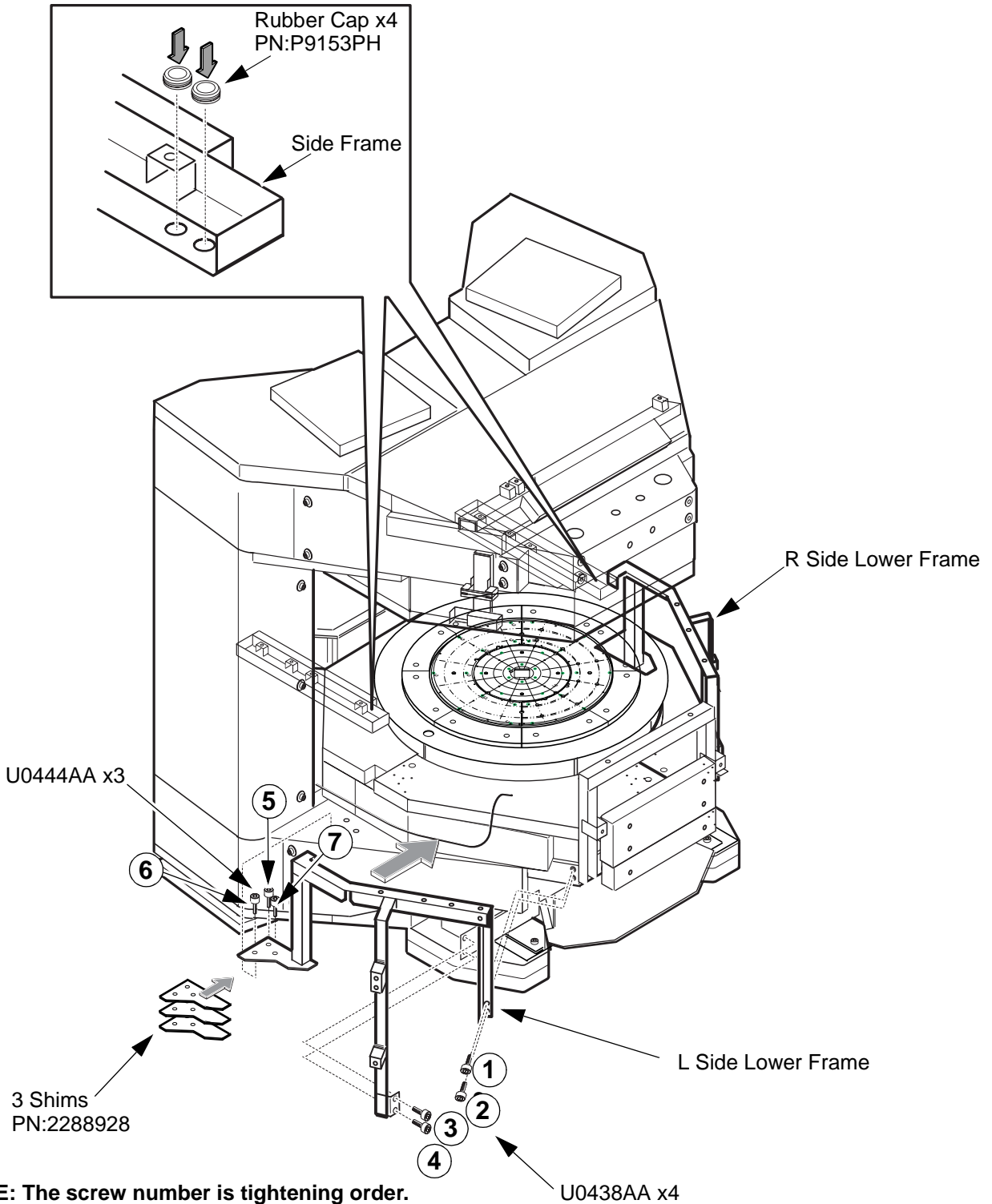

**SIDE LOWER FRAME INSTALLATION**  
ILLUSTRATION 3

Rev 0

**4. Front Upper Frame Installation**

1. Install Insulator(Top Front1) to the magnet with 2 studs(2145353) and 2 screws(U0438AA) / washers(2290018).
2. Install Front Upper Frame to the magnet with plastic washers(2281519:large x4) and 4 screws(N9020YM x4 with washers N9100WM x4). This is temporary tightening.
3. Install Insulator(Top Front2) to the magnet with 2 studs(2145353) and 2 screws(U0438AA) / washers(2290018).
4. Install Insulator(Top Front3) to the magnet with 2 studs(2145353) and 2 screws(U0438AA) / washers(2290018).

**NOTE:** After installing deck plates, adjust front upper frame according to procedure in page 9.

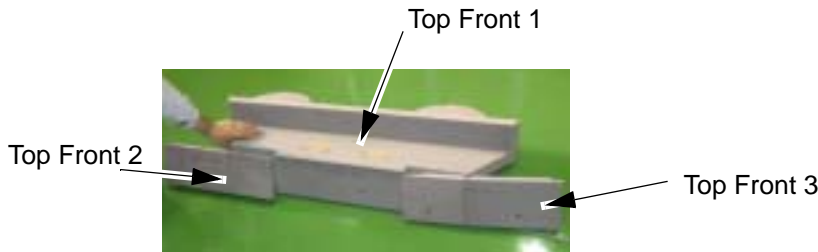

**Top Front1 Insulator**  
 Stud(2145353) x2  
 Washer(2290018) x2  
 Screw(U0438AA) x2

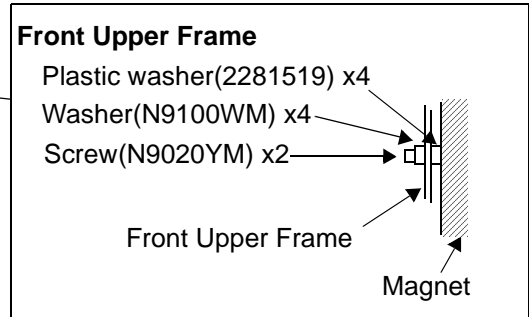

**Top Front2 Insulator**  
 Stud(2145353) x2  
 Washer(2290018) x2  
 Screw(U0438AA) x2

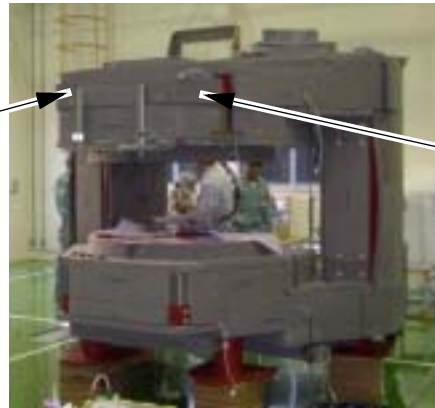

**Top Front3 Insulator**  
 Stud(2145353) x2  
 Washer(2290018) x2  
 Screw(U0438AA) x2

**FRONT UPPER FRAME INSTALLATION**  
 ILLUSTRATION 4

Rev 0

**5. Magnet Deck Plates(Front Deck Plate) Installation (1 of 3)**

1. Set Front Deck Plate onto the front lower frame.
2. Install the No.1,2,3,4,5 and 6 screws(temporary tightening-Inside screw:U0444AAx6) of front deck plate.Do not tighten.
3. Tighten the 6 screws according to tightening order of deck plate.
4. Adjust height of front deck plate become to horizontal surface using level gauge.
5. Tighten the 4 screws of front lower frame.

**NOTE:**

Do not install rear deck plates in this procedure.  
This plates will be installed in rear cover installation.

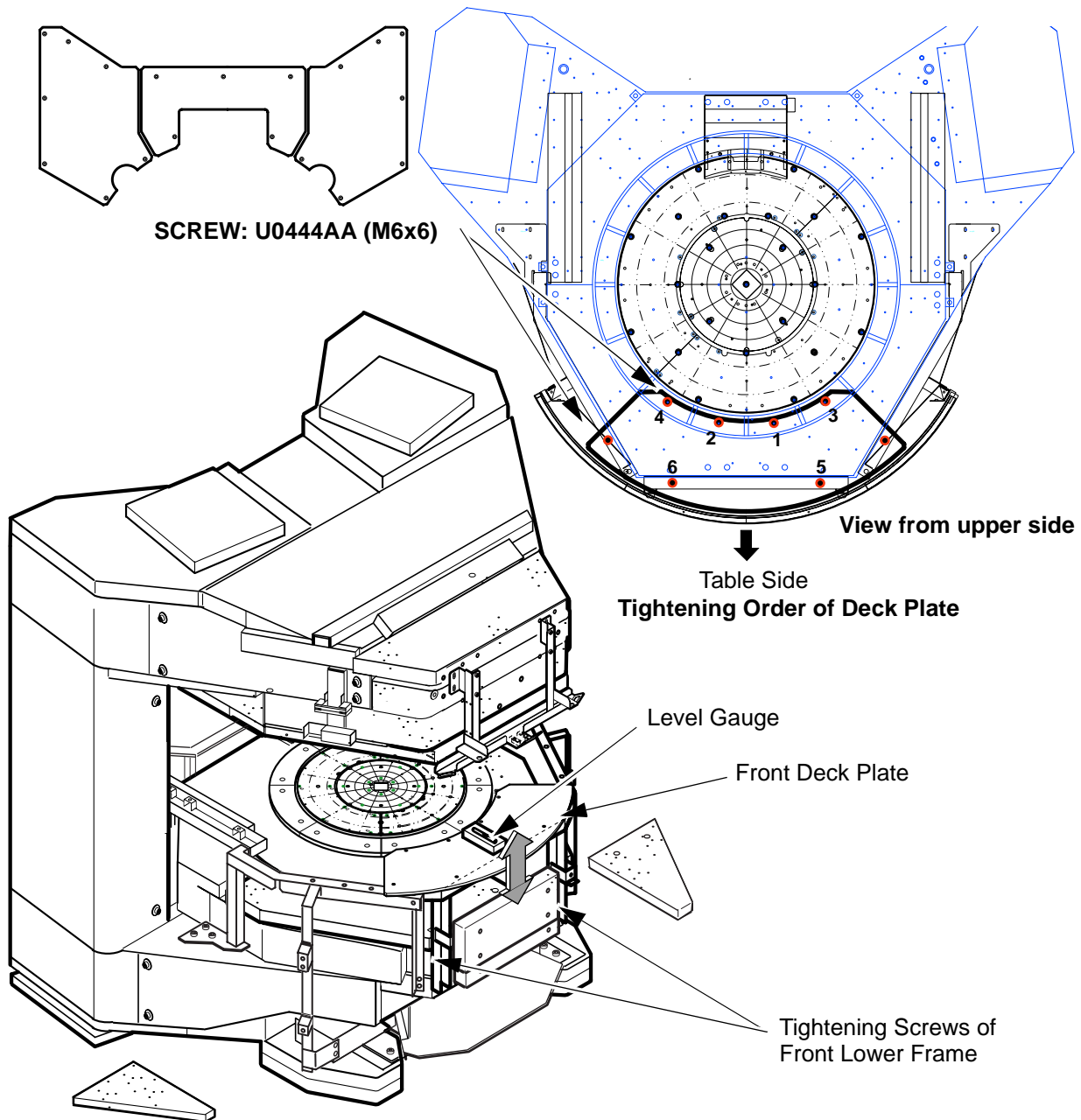

**MAGNET FRONT DECK PLATES INSTALLATION  
ILLUSTRATION 5**

Rev 0

**5. Magnet Deck Plates(Front Side Deck Plates) Installation (2 of 3)**

1. Install R and L Side Deck Plates onto the side lower frames with 36 screws.Do not tighten.
2. Tighten 36 screws of R and L side deck plates according to tightening order.
3. Tighten 2 screws (No.16) of front deck plate.
4. Check that the height of side deck plates are horizontal surface using level gauge.
5. Check that the all deck plates are horizontal plane.If not,readjust the front and side frames.

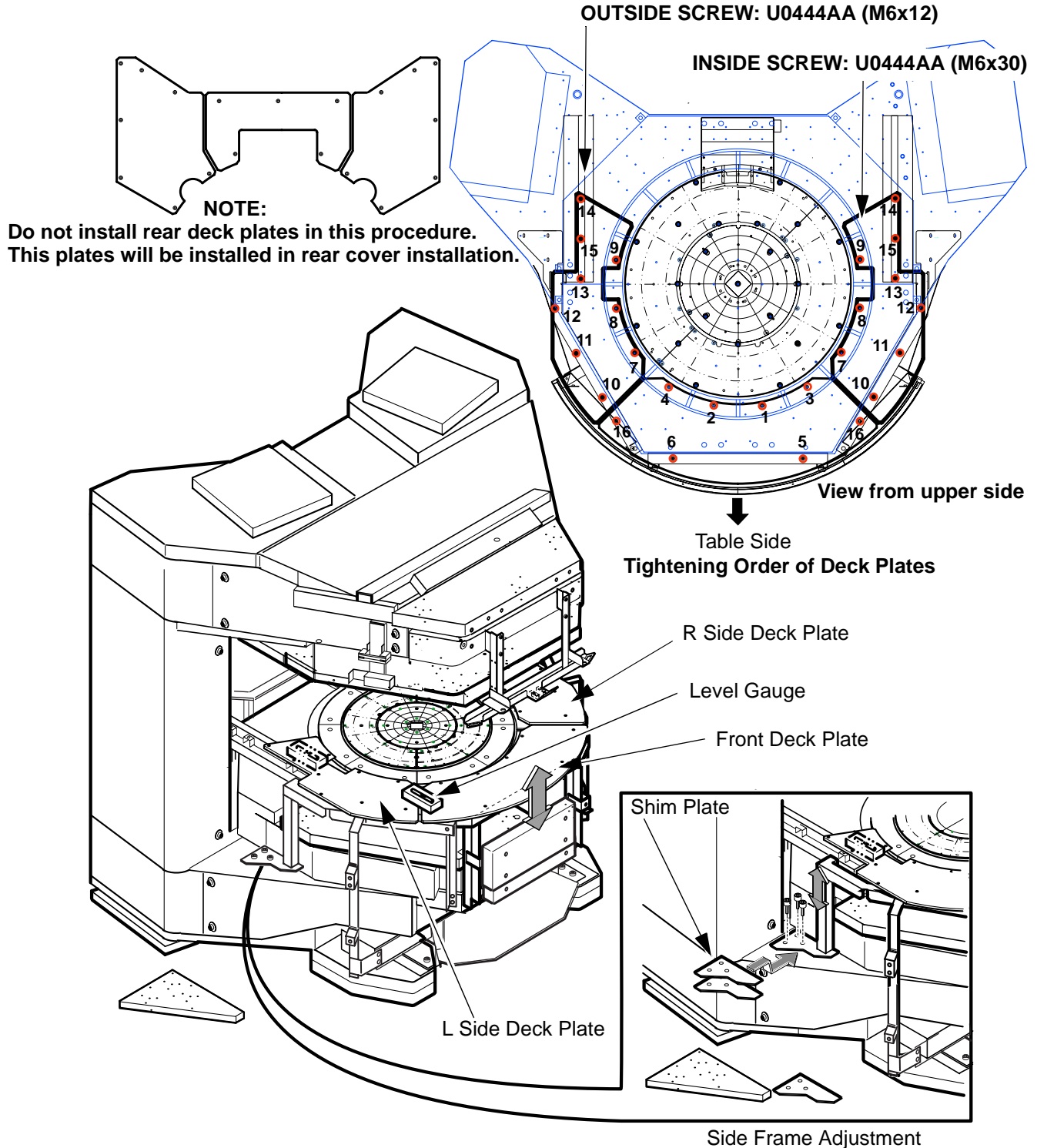

**MAGNET FRONT DECK PLATES INSTALLATION(CONTINUED)**  
ILLUSTRATION 6

Rev 0

**5. Magnet Deck Plates(Front Side Deck Plates) Installation (3 of 3)**

- 6. Install BORE D3 and D2 Insulators to the magnet with 2 studs(PN:2145353) and 2 washers(PN:2290018)/screws(U0438AA) for each side.
- 7. Install 2 Insulators(SIDE FLL x2) to magnet lower front side with tape.
- 8. After installed front deck plates, perform front upper frame adjustment. (go to next page.)

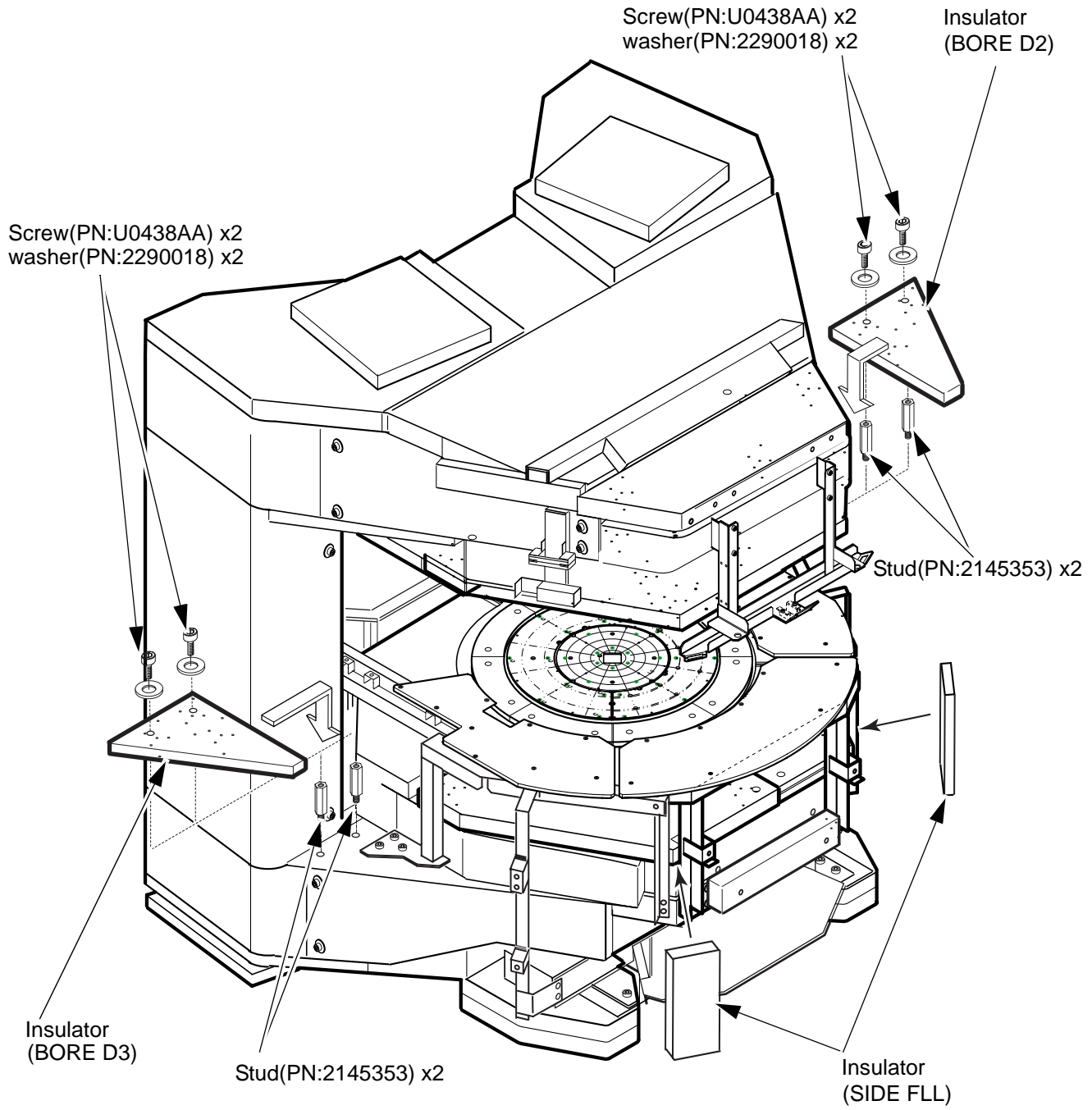

**MAGNET FRONT DECK PLATES INSTALLATION(CONTINUED)**  
ILLUSTRATION 7

Rev 0

### 6. Front Upper Frame Adjustment

**NOTE: This adjustment needs two persons.**

1. Loosen 4 screws fixing front upper frame to the magnet upper side.
2. Adjust front upper frame position become to dimension of 568 +/- 1 mm from front deck plate surface to front upper frame at two points.
3. Tighten 4 screws.
4. Check that the dimension is 568 +/- 1 mm.

**NOTE: If this adjustment is not properly, front cover can not be installed to frames.**

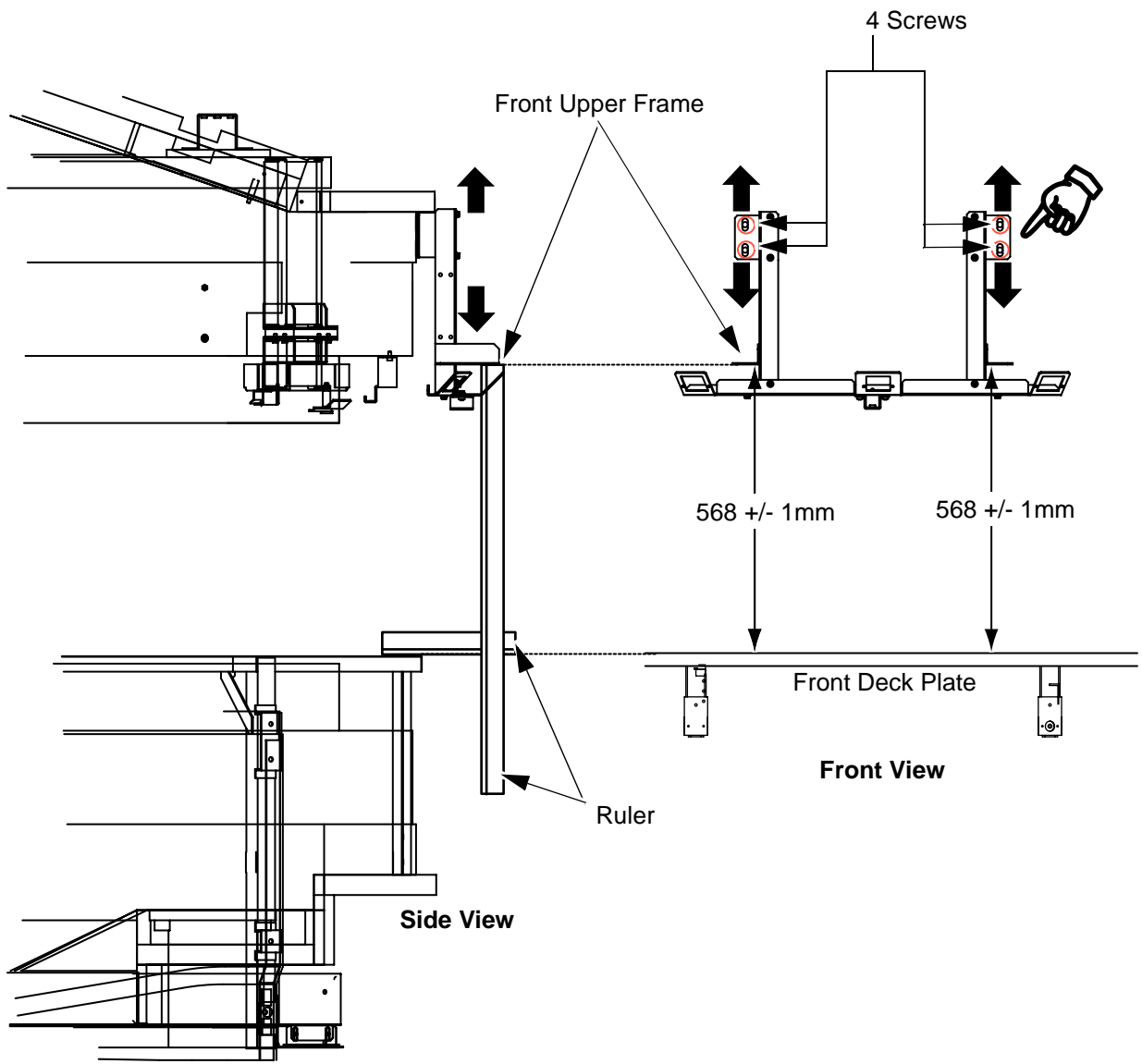

**FRONT UPPER FRAME ADJUSTMENT  
ILLUSTRATION 8**

Rev 0

**Revision History**

<b>Rev</b>	<b>Date</b>	<b>Author</b>	<b>Primary Reasons For Change</b>
0	Nov 26, 2002	Y. Masumo	Initial Release for YD Magnet