

# TABLE OF CONTENTS

- table of contents .....1**
- 1- Introduction.....2**
- 2- Operator Workspace Cabinet.....3**
  - 2-1 SCSI Expansion Box.....3
  - 2-2 IBM Compatible Personal Computer .....3
  - 2-3 Bit 3 Fiber Optic Interface .....3
  - 2-4 Model 800 Ethernet Hub .....3
  - 2-5 Power Module .....3
- 3- Operator Workspace Table.....4**
  - 3-1 SGI Host Computer.....4
    - 3-1-1 Computer Modules.....4
    - 3-1-2 CPU and Memory Details.....4
    - 3-1-3 Power Requirements.....4
    - 3-1-4 Internal Disk Devices .....5
  - 3-2 Workspace Interface Module .....5
  - 3-3 Host Monitor.....5
  - 3-4 Keyboard and Mouse .....5
  - 3-5 SCSI Serial Expansion Module .....5
  - 3-6 Serial Converter Box .....6
- 4- Optional Data Storage Devices .....7**
- revision history .....8**

**DESCRIPTION**

This document relates to Signa Horizon Release 8.2 Operator Workspace Subsystem.

**1- INTRODUCTION**

The purpose of this document is to outline the details for the Operator Workspace subsystem. The Operator Workspace has two main components. The Operator Workspace Table, and the Operator Workspace Cabinet. See Illustration 1-1.

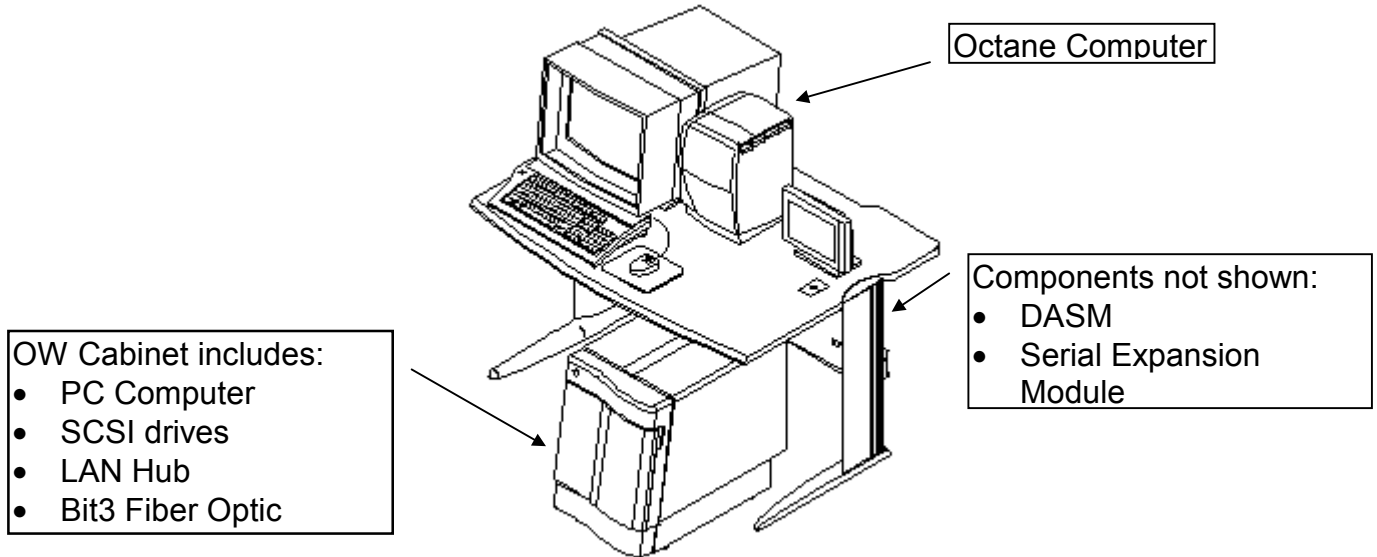

**OCTANE OPERATOR WORKSPACE**  
ILLUSTRATION 1-1

The Computer and Console implement a security system which uses hardware and software to deter the unauthorized use and/or modification of proprietary and purchased option software residing in the Computer. The security system ensures that only authorized users (service person or service contract holder) are allowed to access and execute proprietary software and prohibits execution of purchased option software on unauthorized systems.

## **2- OPERATOR WORKSPACE CABINET**

### **2-1 SCSI Expansion Box**

The SCSI expansion box includes all the system drives.

- MOD Drive
- CD-ROM Drive
- Legacy DAT Drive (Option)
- Legacy OD Drive (Option)

### **2-2 IBM Compatible Personal Computer**

The PC will now have Windows 95™ installed with release 8.2.

### **2-3 Bit 3 Fiber Optic Interface**

The Bit 3 Fiber Optic Interface remains the same for release 8.2.

### **2-4 Model 800 Ethernet Hub**

The LAN Hub remains the same for release 8.2

### **2-5 Power Module**

The AC Distribution Box is located in the Operator Workspace Cabinet under the SCSI Expansion Box. This provides power to the SCSI Expansion box as well as the WIM.

### 3- OPERATOR WORKSPACE TABLE

#### 3-1 SGI Host Computer

The SGI Octane Computer is housed in a chassis that sits on the workspace table. All external connections are on the back of the chassis.

Refer to Illustration 3-1 for the computer output connections.



**OCTANE REAR CONNECTIONS**  
ILLUSTRATION 3-1

#### 3-1-1 Computer Modules

The Host Computer is made up of easy access modules. For replacement procedures, refer to the SGI Octane Workstation Replacement Parts.

- PCI Module - The PCI module is a card cage housing the Ethernet card and the SCSI-3 card.
- XIO Module - The XIO module has 4 slots and houses the video graphics and I/O. The VCR option is also installed in this module.
- System Module - The system module houses the CPU and the memory along with many of the I/O ports which interface to the rest of the system.

#### 3-1-2 CPU and Memory Details

The following are the CPU and memory details:

- R10K CPU 195 MHz
- 64-bit architecture
- 64K Primary cache with a 1MB cache upgrade
- 4MB TMRAM upgrade (graphics)
- Base has 128MB with an additional 128MB upgrade

#### 3-1-3 Power Requirements

- AC Power Input
- Main Power Supply
- Auxiliary Power Supply
- External Power Connectors

### 3-1-4 Internal Disk Devices

- **Storage Device Controller(s)** - The SGI Host Computer mother board has two built in SCSI-II ports to communicate with peripherals.
- **Hard Disk Drive** - The Host Computer can accommodate three hard disk drives. The system uses two of the three hard drive slots. The mounting accepts a standard drive mounted in a sled tray for easy service access. The system interface is a SCSI daisy chain cable with a removable connector which is a 50 position dual row header.

### 3-2 Workspace Interface Module

The Workspace Interface Module (WIM) remains the same for release 8.2. However, the power supplied to the WIM is now housed in the AC Distribution box located in the operator workspace cabinet.

### 3-3 Host Monitor

The host monitor used by the OpenSpeed system is a NEC 21-inch flat panel. The panel is connected by cable directly to the SGI Octane video out. Power is supplied by a brick power supply plugged into the Work Space power strip.

### 3-4 Keyboard and Mouse

The Keyboard contains an emergency stop button which can be used by the operator to power down certain system cabinets. When the button is pressed, a signal is sent to the TYME-II Board in the System Cabinet. This sends an E-Stop signal to the PDU, which causes power shut-off to the RF/Pen Cabinet, Gradient Cabinet, Shim Power Supply, and Magnet Power Supply Cabinets.

### 3-5 SCSI Serial Expansion Module

This module provides 8-port connections for SCSI serial connections.

### 3-6 Serial Converter Box

In OpenSpeed, the Serial Converter Box, See Illustration 3-2 is used to convert the SGI Octane RS 232 serial ports to RS 485 so that that the computer can communicate with the TCU, (Temperature Control Module). And RS 422 for communications with the Coil ID Unit.

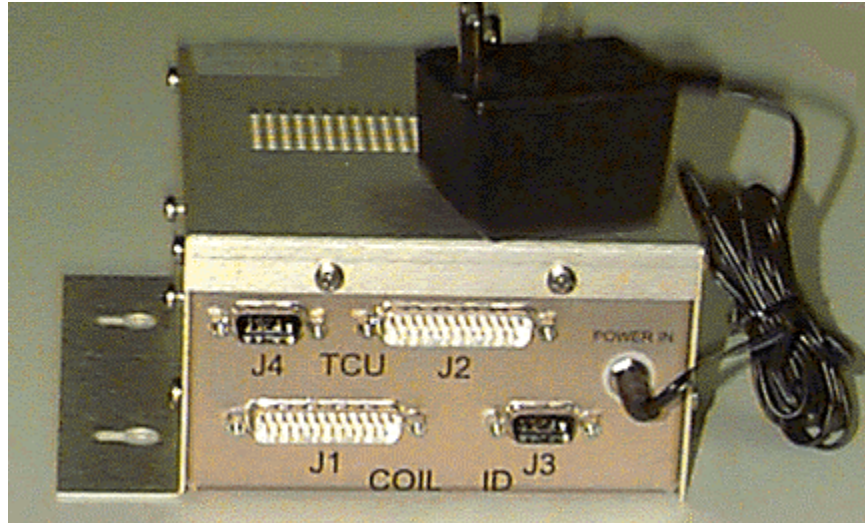

ILLUSTRATION 3-1  
SERIAL CONVERTER BOX

Port 5 on the Octane computer attaches by cable to J1 of the interface box. J3 then is attached by cable to the Coil ID. Port 2 on the Octane computer attaches by cable to J2. Then out through J4 to the TCU.

Power is supplied by a power supply brick, which converts 120VAC to 9VDC.

#### **4- OPTIONAL DATA STORAGE DEVICES**

The following optional external devices can be added to the system:

- Imaging Camera
- Remote Video Monitor
- Line Printer
- VTR/VCR

## REVISION HISTORY

REV	DATE	AUTHOR	PRIMARY REASONS FOR CHANGE
A	Apr 28, 1998	K. L-P	Initial version
0	May 15, 1998	K.L-P	Added Illustration 3-1.
1	Aug, 10, 2000	R. Hawthorne	Added section 3-6 talking to the serial converter box.