

TABLE OF CONTENTS

Table of contents	1
1- Overview	3
2- Integrated Operator Workspace (OW)	3
2-1 Operator Workspace Table	3
2-2 Operator Workspace Cabinet	3
3- Systems cabinet	4
3-1 ISE Chassis	4
3-2 Transmit Subsystem	4
3-3 Receive Subsystem	5
4 GRFD Cabinet	5
4-1 RF Amplifier.....	5
4-2 Gradient Power Modules	6
4-3 Power Distribution Unit (PDU)	6
5 Magnet Enclosure and patient handling	7
5-1 Scan Room Interface (SRI)	7
5-2 Patient Comfort	7
5-3 Patient Alignment Lights.....	7
5-4 Longitudinal Drive	7
5-4 PAC Module	7
5-6 Penetration Panel	8
5-7 Pneumatic Patient Alert System	8
6- coils	8
6-1 Gradient Coil Assembly	8
6-2 RF Body Coil	8
6-3 Head Coil	9
7- Magnets	9
8- Peripherals	9
8-1 Imaging Camera	9
8-2 Line Printer	9
Revision history	10

Description - This is an overview of the Signa Ovation system.

The block diagrams show the major components, where they are located.

System Block Diagram

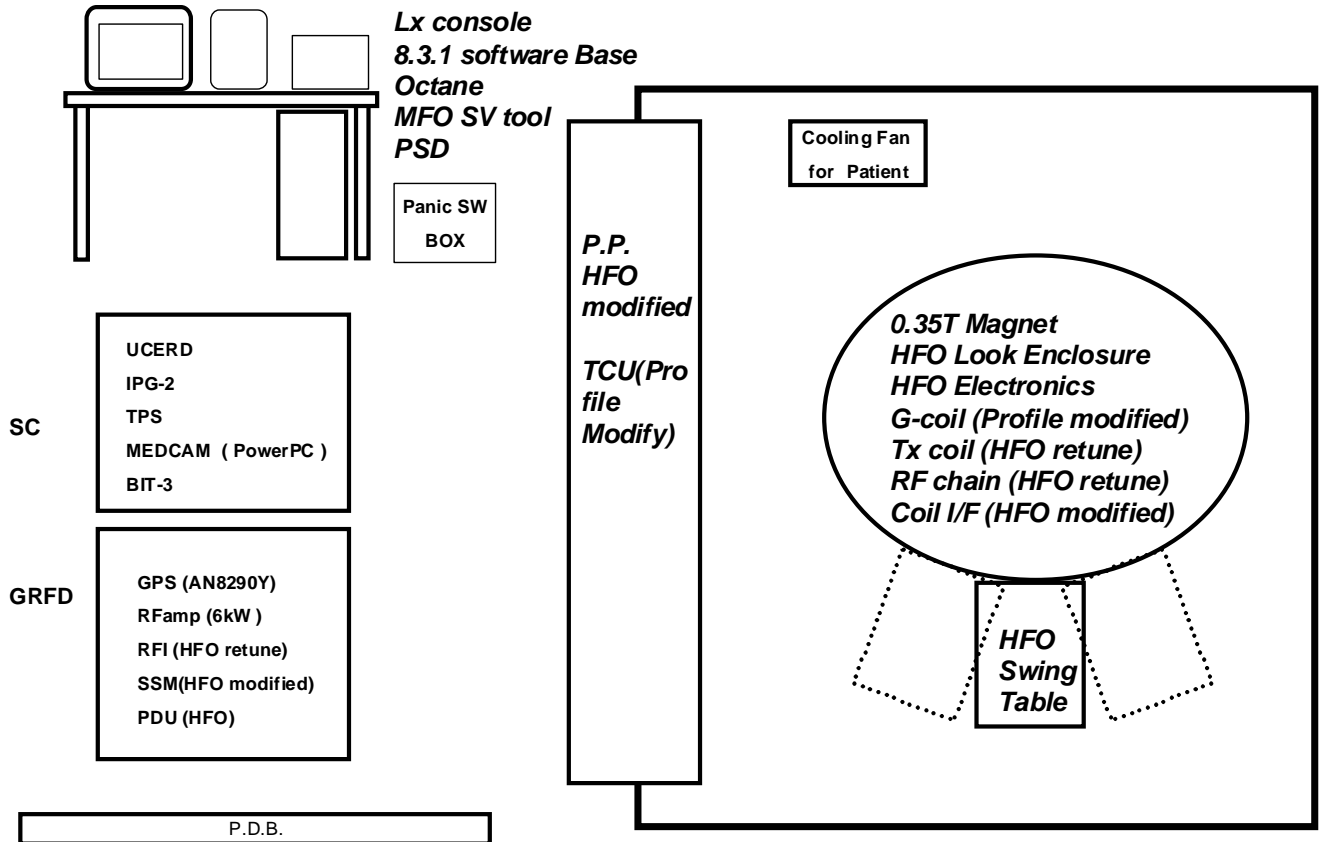

1- OVERVIEW

The Signa Ovation system is made up of a variety of subsystems. These subsystems include the Operator Workspace, Gradient Driver subsystem, RF subsystem, Magnet subsystem, Patient Handling, Gradient/ RF waveform generation subsystem.

The system consists of three cabinets: Systems Cabinet (same as 8.x version), the GRFD Cabinet (includes the Gradient, RF, and PDU subsystems), and the Operator Workspace.

2- INTEGRATED OPERATOR WORKSPACE (OW)

Illustration 2-1 shows Operator Workspace. There are multiple components located on the Integrated Operator Workspace (OW). Two main areas of the Integrated Operator Workspace are the OW Table, and the OW Cabinet.

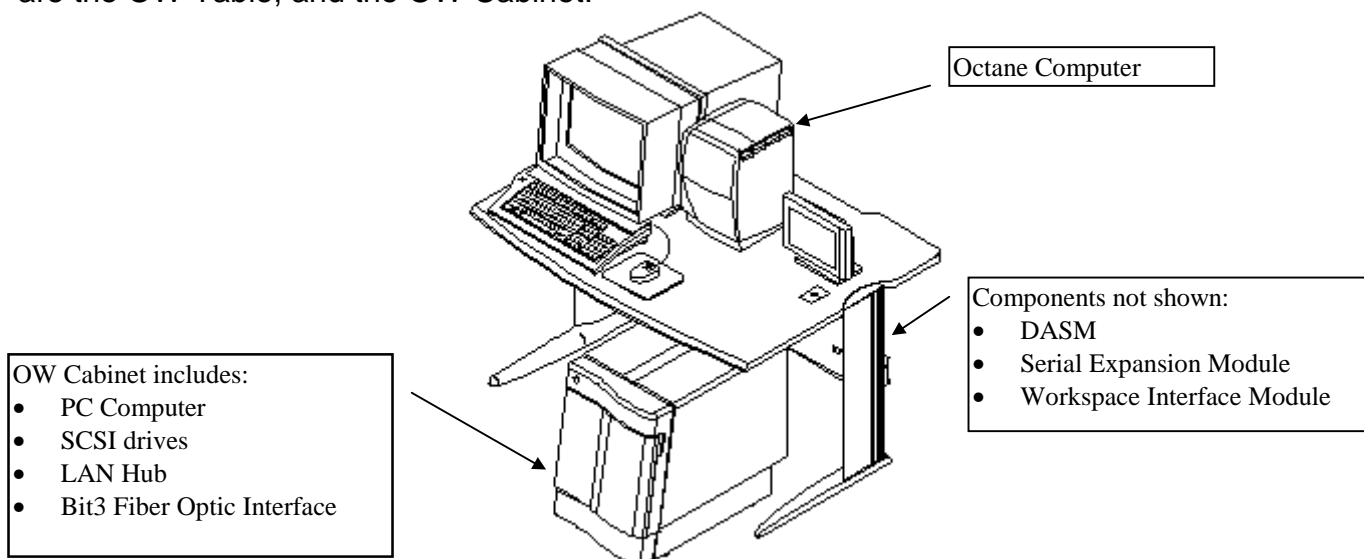

ILLUSTRATION 2-1
OPERATOR WORKSPACE

2-1 Operator Workspace Table

The Operator Workspace Table holds the host LCD display, the PC LCD panel, a duplex keyboard, mouse, modem, DASM, and the Octane Host Computer. The duplexing keyboard and mouse are capable of interfacing with both the Silicon Graphics Incorporated (SGI) host computer, and with the IBM-compatible personal computer (housed in the Operator Workspace Cabinet).

2-2 Operator Workspace Cabinet

The Operator Workspace Cabinet is an enclosure that houses the IBM-compatible PC and the miscellaneous drives needed for the system (CDROM and MOD). In addition, this cabinet houses the Model 800 Ethernet Hub and a Specialix brand serial expansion module.

3- SYSTEMS CABINET

The System Cabinet contains the Integrated System Electronics (ISE) and the TYME-II.

The ISE performs all the data collection and reconstruction of RF signals. It receives commands and RF waveform information from the SGI Host via the TYME-II Board and the IPG Board. It communicates to the host computer through the Bit3 fiber optic interface. The Exciter Module receives IPG data via the ISE Backplane. These inputs are combined to generate real-time RF waveforms which are sent by the Digital Exciter to the GRFD Cabinet. The detected signal (by the RF coil) is demodulated by the Digital Receiver. The data acquisition portion of the UCERD performs any preprocessing before transferring the data to the memory board(s). The Host Computer reconstructs the raw data into an image file(s).

The TYME-II receives certain system "status" signals (E-Stop, door open, etc.), processes the signals, and transmits corresponding "action" signals to the appropriate devices (PDU, TYME Board, Manifold I/F Board, etc.).

3-1 ISE Chassis

The Integrated System Electronics (ISE) subsystem provides excitation of selected patient nuclei at the Larmor frequency, detects returning echoes, and reconstructs the raw data into an image. This is accomplished by computer-modulated waveforms input to the UCERD exciter. This low-level transmitted signal is amplified by the RF amplifier. The resultant high-level signal is input to an RF coil located in the magnet. A low-level received signal (echo) is then detected from the sample, or patient, and is amplified by a preamplifier, located at the magnet. This amplified received signal is input to the UCERD receiver. The receiver demodulates the signal and digitizes it so that it can be processed by the Host Computer, and the reconstructed image can be transferred to the computer. The transmitter and receiver have connections via two transmit/receive (T/R) switches for two operator-selected output modes of the RF amplifier. Each coil is functionally similar to an antenna.

3-2 Transmit Subsystem

The transmit subsystem consists of six major components:

- Integrated Pulse Generator (IPG)
- UCERD exciter (Digital Exciter Board (located on the UCERD)) which contains the Exciter DAC Board and Narrow Band Exciter Module
- 6kW RF Amplifier located in the GRFD Cabinet
- System Support Module (SSM) (located in the GRFD cabinet), containing APM Board, Power Supplies and the CPD Board

3-3 Receive Subsystem

The receive subsystem consists of three major components:

- T/R Switch for each coil
- Preamplifier
- UCERD receiver (Digital Receiver Board which contains the Receiver A/D Board and Narrow Band Receiver Module).

Most of the UCERD subsystem hardware is contained in the System Cabinet, GRFD Cabinet, Magnet Enclosure, and Table Interface.

4 GRFD CABINET

The GRFD Cabinet contains the RF Amplifier, RF Interface (RFI), System Support Module (APM, Power Supplies, and Pin Switch Driver with SPC), three gradient amplifiers, and a System Control Assembly (SCA).

4-1 RF Amplifier

The solid-state RF amplifier provides power to the RF coils (body, head, etc.) The RF amplifier requires signals from several other subsystems for proper operation which include: RF input signal from the UCERD, mode (body or head), frequency and operating commands originating from the IPG Board, the UNBLANK signal which is received from the Digital Exciter Board via the CPD Board, and the Power Monitor HV REL signal to control a 12 Vdc relay as a hard-wired safety feature.

4-2 Gradient Power Modules

The gradient portion of the GRFD cabinet consists of three switch-mode amplifiers, a switch-mode power supply and a system-control assembly mounted in a rack assembly.

The purpose of the gradient amplifiers is to produce highly stable three-axis waveforms to drive the gradient coils of a magnetic resonance imaging (MRI) system. The amplifier system accepts digital waveform data, converts the data to analog signals, and amplifies them to a high power level.

The rack assembly provides support and cooling air to the electronic modules. Air flow for the system is from front to back. Fans are located on a swing out panel in the rear. All modules mount onto the rack support rails.

The power supply unit (PSU) transforms and regulates the AC input to produce a high voltage output. The high voltage output is converted to the output signal by the axis amplifiers.

The System Control Assembly (SCA) includes the operator interface, and the auxiliary voltage supplies. The auxiliary voltages power the logic, analog circuitry, and fans. Local switching and an alpha-numeric display are located within the SCA unit. Control information from the SCA to the amplifiers, and status information from all three amplifiers to the SCA, are transferred on a common ribbon cable "Amplifier Bus".

The amplifiers provide the high current drive to the gradient coils, and include all control interfaces and the input and output filters. The axis amplifier is a field replaceable unit. Connectors are provided on the rear of the amplifier for DC power from the PSU, and terminals for connection to the gradient load cables.

4-3 Power Distribution Unit (PDU)

The PDU portion of the GRFD cabinet provides power for the entire MR system, excluding magnet room accessories (e.g., oxygen monitor and Emergency Rundown Unit, or Magnet Monitor). The PDU with 20 kVA transformer can transform input power of 480 V or 380/400/415 V for international unit into an output voltage of 208 VAC.

5 MAGNET ENCLOSURE AND PATIENT HANDLING

5-1 Scan Room Interface (SRI)

The SRI Module processes control and status data in the scan room, and exchanges scan room data with the TYME card (located in the TPS/ISE chassis). In the scan room, data inputs to the SRI Module come from the Longitudinal Drive Assembly, the Dock Assembly, and the Magnet Enclosure Control Switches, while data outputs go to the Magnet Enclosure Status Indicators. The SRI is located on the top of the magnet.

5-2 Patient Comfort

The Patient Comfort Module consists of a bore vent, bore lighting, and a microphone and speaker for patient-to-operator communication. The module is located on top of the magnet.

5-3 Patient Alignment Lights

Three fixed patient alignment lights are mounted on the front face of the magnet frame. These provide a perfectly aligned wraparound beam pattern for the coronal, axial, and sagittal planes in the magnet bore. The three fixed lights are laser diodes for Cx magnets.

5-4 Longitudinal Drive

The Longitudinal Drive system moves the patient cradle in and out of the magnet bore. The patient cradle can also be moved 120mm laterally from center, however, this movement requires a manual procedure. Table can be swing +/- 25 ° from center manually.

5-4 PAC Module

The Physiological Acquisition Controller (PAC) Board acquires, digitizes, and transmits physiological signals from the patient to the IPG board. The system uses these signals to synchronize the scanner to physiological events such as patient respiration, heart beat, and pulse.

Respiratory Compensation is used during torso scans to help eliminate artifacts caused by patient breathing motion. The compensation is based on the patient's respiratory rate, which is measured by a bellows placed across the patient's chest or abdomen.

Cardiac gating is used when the specific position of the heart is important for imaging. The gating is based on the patient's heart motion, which is monitored by electrocardiogram (ECG) leads placed on the patient's chest. Peripheral gating is used to minimize the effect of blood flow through the body. A plethysmograph (photopulse sensor) is placed on the patient's finger to detect blood flow.

5-6 Penetration Panel

All system interconnections penetrating the RF shielding surrounding the exam room are filtered to minimize RF interference. This includes electrical, fiber optic, and air lines.

The Temperature Control Unit (TCU) is located on the Penetration Panel. This assembly controls the temperature of the magnet since temperature variations can affect image quality.

5-7 Pneumatic Patient Alert System

The Pneumatic Patient Alert System is a stand-alone system that allows the patient to contact the operator even when console volume is turned down. This patient-to-operator contact occurs when the patient squeezes a hand-held air bulb; this sets off an audible and visual alarm near the operator.

6- COILS

The gradient subsystem produces calibrated magnetic fields based on digital input received from the IPG. The gradient subsystem consists of:

- Gradient Coil Assembly
- Gradient Power Modules (Refer to Section 4-4)

6-1 Gradient Coil Assembly

The Gradient Coil Assembly is a two discs constructed of the fiberglass that attaches to the bore of the magnet. The Gradient Coil Assembly contains three separate electrical coils (x, y, and z) that are used to produce the spatial field gradients that linearly vary the strength of the magnetic field throughout the image volume. This gradient field, together with the RF pulses, defines the image slice thickness and the image plane.

6-2 RF Body Coil

The receive function of Body Coil is not used for human imaging. It is just used for maintenance purpose. The Body Quadrature T/R Switch and Hybrid Assembly split the output of the RF amplifier into four signals, I and Q, that are ninety degrees out of phase with each other, and apply these signals to the inputs of the body coil. A body TR bias signal is applied to the heliax cable at the RFI assembly. This couples the RF amplifier output to the hybrid input, and couples the reflected power signal to the internal load.

During receive, the RF amplifier and load are disconnected from the hybrid, so that all the received signals from the coil are applied to the input of the preamplifier for best receive sensitivity.

6-3 Head Coil

Quad Head Coil consists of two coils: solenoid coil and birdcage coil. The birdcage coil is used to linear transmission. Solenoid and birdcage coils can detect the quadrature phase of nMR signal.

The echo from the patient is extremely small in amplitude. To keep it from being obscured by noise, the preamplifier boosts the level of the echo before transmitting it along the coaxial cable from the exam room to the receiver.

7- MAGNETS

The 3,500 gauss magnetic field is produced by a permanent magnet.

8- PERIPHERALS

8-1 Imaging Camera

The system interfaces with a laser camera, which provides a means to get hard copy output of images on film. Several formats are available on one film size.

8-2 Line Printer

This option provides a means of creating a hard copy record of ASCII data (not used to print images or graphics).

REVISION HISTORY

REV	DATE	AUTHOR	PRIMARY REASONS FOR CHANGE
0	Mar 9, 2001	Y. Masumo	Initial version (Modified from HFO)