

TABLE OF CONTENTS

TABLE OF CONTENTS	1
1- MAGNETIC FIELD CONSIDERATIONS	2
2- CRYOGENS	2
3- OXYGEN MONITOR	3
4- HIGH VOLTAGES	4
5- RF FIELDS	4
6- OSHA LOCKOUT / TAGOUT REQUIREMENTS	4
6-1 Scope	4
6-2 Application	4
6-3 Exceptions	5
6-4 Purpose	5
6-5 General Application	5
6-6 Definitions	5
6-7 Application of Control	6
6-8 MR Lockout of Signa Horizon Systems	6
7- ELECTRICAL INSTALLATION AND SERVICING	7
8- SURFACE COIL WARNING LABELS FOR SIGNA HORIZON	8
9- PHANTOM SPILL PROCEDURES	9
REVISION HISTORY	13

Description - Contains safety overview for the Signa system, including magnetic fields, cryogenics, high voltages, RF fields, OSHA lockout / tagout requirements, and new Signa Horizon surface coil warning labels. Specific cautions, warnings, and dangers for these areas are provided in procedures where applicable.

1- MAGNETIC FIELD CONSIDERATIONS

The magnetic field strength used in MRI is approximately 25,000 times that of the earth! This field is three-dimensional; therefore, magnetic field precautions must be applied to the floors above and below the magnet, as well as to the surrounding space on the same level.

Take the following precautions to prevent danger to persons and equipment:

- Post WARNING signs outside the 5 gauss zone, alerting personnel with cardiac pacemakers, neurostimulators, and other biostimulation devices of the affect of the magnetic field on these devices.
- Post WARNING signs at the termination point of the magnet cryogenic vent, alerting personnel to the sudden discharge of freezing gases and small objects.
- Post SECURITY signs outside the magnet room, alerting personnel of high magnetic field and not to bring ferromagnetic objects in the magnet room.
- Do not bring ferromagnetic objects (e.g., tools, pens, tape measures, steel-toe shoes, vacuum pumps, etc.) into the magnet room. Large metal objects must not be brought near the outside walls of the magnet room. For Signa Horizon, refer to *Direction 2120460, Signa Horizon Pre-Installation, Section 2, Room Layouts*, for equipment proximity limits.
- Analog watches (those with hands) and magnetic-coded credit cards can be destroyed if taken near the magnet.
- Magnetic tapes can be erased, recording heads magnetized, and camera shutters ruined by strong magnetic fields.
- Use only non-magnetic cylinders and dewars when transferring cryogenics into an energized magnet.

2- CRYOGENS

Liquid helium and liquid nitrogen are odorless, colorless, and non-toxic; they are, however, at extremely low temperatures: liquid helium at 4.2K (−452°F) and liquid nitrogen at 77.6K (−320°F). These liquids cause severe burns if they come in contact with skin. Wear protective clothing and gloves that are non-absorbent so that any spillage will run off and not be trapped against the skin.

Contact of liquid cryogenics or gas with the eyes can cause severe frostbite. Wear safety goggles or a face shield.

Gaseous helium and nitrogen displace air without warning, and can cause rapid asphyxiation and even death if there is not sufficient ventilation. Always **be sure** that the oxygen monitor is functioning properly prior to transferring any cryogenics. If the alarm mode of the oxygen monitor is activated, immediately determine the cause. If ventilation is a problem, **correct the situation**. Be sure that the oxygen monitor is reading a safe level before you enter the affected area to continue with service procedures. Always store gas cylinders and cryogen dewars in a well-ventilated area.

Rooms in which cryogen liquids are stored and handled must be designated no smoking areas. The extreme low temperatures of liquid helium and nitrogen cause oxygen from the air to liquify on cold surfaces (e.g., on transfer tubes) and increase its local concentration. There is a potential fire danger if grease or oil come in contact with these surfaces since they are combustible substances.

If you are in the magnet room and a quench occurs follow these basic rules:

- Remain calm; don't panic.
- Open the scan room door, prop it open, and exit the room immediately.
- Turn on the exhaust fan for the scan room (if not automatically turned on by oxygen monitor).
- If the door cannot be opened, stay near the floor. This is where the oxygen is.
- Open or, if necessary, break the window to relieve pressure in the magnet room.
- Prop open the scan room door, and exit the room immediately.
- If the door cannot be opened, exit through the window.
- Do not enter the magnet room until the oxygen monitor indicates a safe level.

3- OXYGEN MONITOR

Note

Since March 1, 1994, the oxygen monitor is no longer delivered with GE MR systems. Oxygen monitors are still available as an accessory from GE Medical Systems through Diagnostics Imaging Accessories (DIA).

The oxygen monitor sensor element should be replaced every six to twelve months (beginning in 1994, a new five- year oxygen sensor element became available). They are shipped in transparent airtight packages, and should be inspected upon receipt. The cells contain a strong caustic potassium (KOH) solution. If the cell membrane is punctured, do not open the package.

4- HIGH VOLTAGES

The plate voltage used by high power vacuum tube amplifiers is the most dangerous hazard in the RF subsystem. Lethal potentials in excess of 4100 volts, with momentary current capability greater than 100 amps, are present in the amplifiers and their power supplies during operation.

Interlock switches are provided on the covers of power supply and amplifier decks to minimize the danger of electrocution; however, they should never be taken for granted.

All circuit breakers on the rear of the RF cabinet must be off and tagged, and cabinet power cords must be unplugged before opening any modules containing high-voltage circuitry. Allow at least three minutes for filter capacitors to discharge before removing any module covers for service.

Always assume that a circuit is "hot" until proven otherwise. Discharge high-voltage circuitry by shorting to ground and across terminals of floating power supplies before touching components. Do not rely on bleeder resistors to discharge capacitors. While they will eventually reduce voltages to safe levels, bleeder circuits have time constants as long as several minutes to limit heat dissipation during normal operation.

5- RF FIELDS

General Electric Company policy specifically prohibits service personnel from using any part of their body for a phantom, or dummy load, while testing the power amplifier or related components in the RF subsystem. This restriction protects service personnel from inadvertent overexposure to the heating effects of high energy RF fields, which could occur while servicing with certain safety features bypassed or otherwise disabled.

6- OSHA LOCKOUT / TAGOUT REQUIREMENTS

6-1 Scope

This standard covers the servicing and maintenance of machines and equipment in which the unexpected energization, or start-up, of the machine or equipment could cause injury to employee.

6-2 Application

This standard applies to the control of energy during servicing and/or maintenance of machines or equipment.

6-3 Exceptions

Minor adjustments and other minor service activities, which take place during normal operation, are not covered by this standard if they are routine, repetitive, and integral to the use of the equipment for operation, provided the work is performed using alternative measures that provide effective protection.

This standard does not apply to work on cord and plug-connected electric equipment. Exposure to the hazards of unexpected energization, or start-up, of such equipment is controlled by the unplugging of the equipment from the energy source, and by the plug being under the exclusive control of the employee performing the servicing or maintenance.

6-4 Purpose

Require employers to establish a program, and use procedures for affixing appropriate lockout devices, or tagout devices, to energy-isolating devices, and to otherwise disable machines or equipment to prevent unexpected energization, start-up, or release of stored energy in order to prevent injury to an employee.

6-5 General Application

If an energy-isolating device is not capable of being locked out, use a tagout device. Such device shall be attached at the same location that the lockout device would have been attached.

6-6 Definitions

Energy-isolating device: Mechanical device that physically prevents the transmission or release of energy (i.e., manually operated electrical circuit breaker or disconnect switch).

Energy source: Any source of electrical, mechanical, hydraulic, pneumatic, chemical, thermal, or other energy.

Lockout: Placement of a lockout device on an energy-isolating device, in accordance with an established procedure, ensuring that the energy-isolating device and the equipment being controlled cannot be operated until the lockout device is removed. It is also necessary to attach a tagout device to the lockout device.

Lockout device: A device that uses a positive means such as a lock (either key or combination type) to hold an energy-isolating device in the safe position.

Tagout: Placement of a tagout device on an energy-isolating device, in accordance with an established procedure, to indicate that the energy-isolating device and the equipment being controlled may not be operated until the tagout device is removed.

Tagout device: A prominent warning device, such as a tag and a means of attachment, that can be securely fastened to an energy-isolating device in accordance with an established procedure, to indicate that the energy- isolating device, and the equipment being controlled, may not be operated until the tagout device is removed.

Lockout / tagout: If an energy-isolating device is not capable of being locked out, the site energy control program shall use a tagout system.

6-7 Application of Control

The established procedure for the application of energy control shall cover the following:

- Preparation for shutdown.
- Machine or equipment shutdown.
- Machine or equipment isolation.
- Lockout or tagout devise application.
- Verification of isolation.

Basic rule: All equipment shall be locked out or tagged to protect against accidental or inadvertent operation when such operation could cause injury to personnel.

6-8 MR Lockout of Signa Horizon Systems



SHOCK HAZARD! SOME HORIZON 1.5T UPGRADES USE STANDARD PDUS. STANDARD PDUS ARE NOT LOCKOUT-COMPATIBLE AND CAN ONLY BE TAGGED.

Signa Horizon subsystems that receive power from a Compact Power Distribution Unit (PDU) have access to a dedicated bank of circuit breakers located behind a lockable door. Therefore, to electrically isolate a cabinet, Field Service Engineers need only set the appropriate circuit breaker in the Compact PDU to off and lock the door.

The Mains Disconnect Box supplies power to the Compact PDU. If power to the Compact PDU must be turned off, the Mains Disconnect Box must be shut down and locked out.

WARNING!

SHOCK HAZARD! TO PREVENT POSSIBLE ELECTRIC SHOCK, DO NOT USE THE KEY LOCK ON THE COMPACT PDU DOOR. THE LOCK IS A COMMON LOCK WITH MULTIPLE KEYS AVAILABLE AND DEFEATS THE OSHA REQUIREMENT OF ONE LOCK-ONE KEY. USE THE LOCKING RING AND PADLOCK.

The procedure for locking the Compact PDU is (see Illustration L2056A):

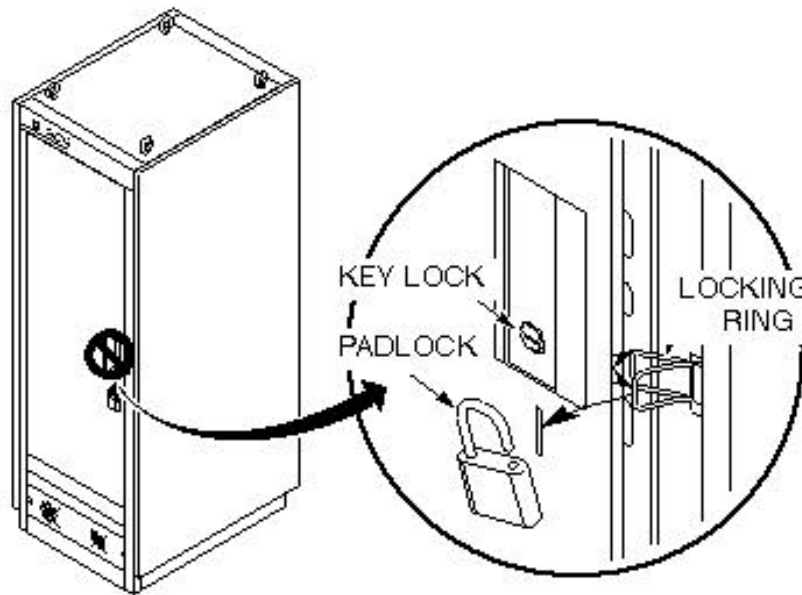

ILLUSTRATION L2056A
LOCKING OUT A COMPACT PDU

1. Open front door of Compact PDU and turn off appropriate circuit breaker.
2. Rotate locking ring out.
3. Close door while guiding locking ring through door slot below key lock.
4. Use a padlock through the locking ring on outside of door to lock PDU Cabinet.
5. Tag the padlock.

7- ELECTRICAL INSTALLATION AND SERVICING

All electrical installations that are preliminary to the positioning of the equipment at the site prepared for that equipment shall be performed by licensed electrical contractors. In addition, electrical feeds into the Power Distribution Unit shall be performed by licensed electrical contractors. Other connections between pieces of electrical equipment, calibrations, and testing shall be performed by qualified GE personnel. The products involved (and the accompanying electrical installations) are highly sophisticated, and require special engineering competence. In performing all electrical work on these products, GE will use its own specially trained field engineers. All of GE's electrical work on these products will comply with the requirements of the applicable electrical codes. The purchaser of GE equipment shall only utilize qualified personnel (i.e., GE's field engineers, personnel of third-party service companies with equivalent training, or licensed electricians) to perform electrical servicing on the equipment.

8- SURFACE COIL WARNING LABELS FOR SIGNA HORIZON

Note

The Surface Coil UFI-compatibility issue and warning labels plan do NOT apply to 1.0T Signa Horizon systems.

With the purchase or upgrade of a 1.5T Horizon, HiSpeed, or EchoSpeed, there are several RF coils that will no longer be compatible with the Signa Horizon system. It is required that these non-compatible coils be removed from the site and returned to GE. A new coil of the same type will be supplied for each of these non-compatible coils before they are removed from the site. This will be accomplished by a marketing promotion, special no-cost S-CATs, or an FMI.

All new and existing surface coils that are compatible with Signa Horizon have a warning tag applied to the coil cable, near the cable connector and, for some coils, a warning tag applied to the cable of the coil next to the coil housing (see Illustration L4806A).

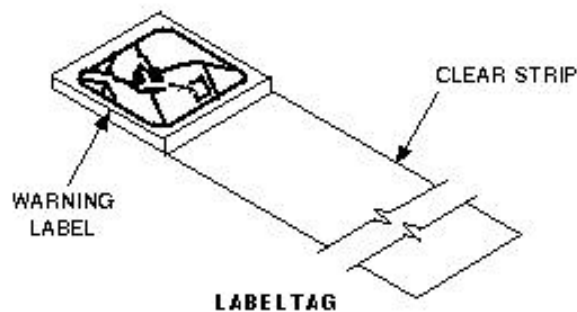

ILLUSTRATION L4806A

SIGNA HORIZON SURFACE COIL WARNING TAG

Also, all Signa Horizon Head Carriages have a warning label, to the right of each of the surface coil and phased array connectors, which states, "WARNING! TO PREVENT PATIENT BURNS, USE ONLY COILS WITH THIS LABEL/SYMBOL NEAR THE CONNECTOR:" (see Illustration L4807A). These warning labels are available English, French, Spanish, German, Italian, Portuguese, Japanese, and Chinese. (English language labels are on the delivered Signa Horizon Head Carriage.

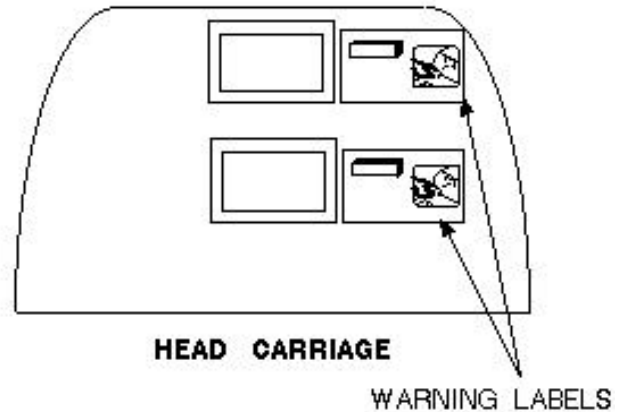
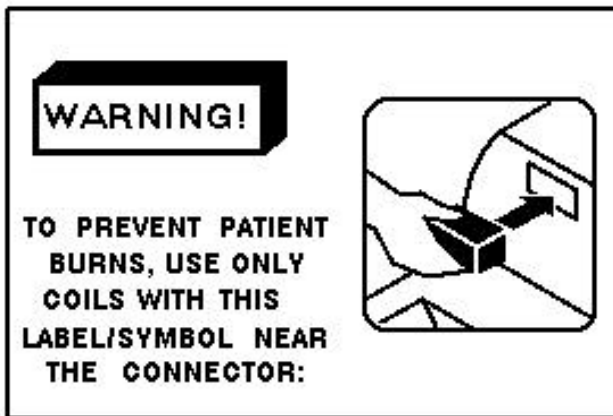

ILLUSTRATION L4807A
 SIGNA HORIZON SURFACE COIL WARNING LABEL

For non-GE-approved surface coils: Refer the customer to the original coil manufacturer for information on coil compatibility with Signa Horizon.

Note

GE makes no claims as to compatibility of coils not approved by GE for use on Signa systems. We have no way of knowing if these non-GE coils are compatible with our software and/or hardware. The customer uses these coils at their own risk, and GE accepts no responsibility for their use.

9- PHANTOM SPILL PROCEDURES

Material Safety Data Sheets (MSDS) were developed to comply with OSHA. Because of the low concentrations of solutions in MR phantoms, they are nonregulated by both DOT and RCRA (Resource Conservation & Recovery Act), with the exception of phantoms that contain phosphoric acid. This document is limited to phantoms shipped in support of MR Signa systems.

An envelope marked "Shipping Docs Enclosed," containing a specific MSDS document, is sent with each phantom shipped to a customer. While some customers may keep these on file, it is apparent, by the number of requests for MSDSs received at headquarters, that many do not. **This creates confusion when a phantom spill occurs on-site, requiring immediate action.** An MSDS covers the chemical contents by product description, hazards identification, toxic information, first aid measures, and handling instructions. This document does not cite a specific spill clean up procedure. Nor does the disposition of faulty, leaking phantoms. In the event of a chemical spill, notify the building security. They will alert the spill team.

Preliminary Procedure

Ensure that the customer has a record of MSDS on file based on the phantom list identified later in this document. If these sheets are not available, obtain the missing MSDS according to the following procedure:

1. Log on to the GEMS IBM mainframe system from a "green screen," or via a laptop computer.
2. Select PCICS from the mainframe "samon" screen followed by your user name and password.
3. Select MANUFACTURING INQUIRY. <Enter>
4. Select PF11, HAZARDOUS MATERIALS.
5. Select PF1, MSDS Inquiry Menu.
6. Enter MSDS number on line 1. (A list of MSDS numbers by phantom type follows below.)
7. Select PF1, SELECT BY MSDS NUMBER.
8. Select PF5, for print command. File these MSDS report where they can be readily accessed.
9. If you are still unable to locate a set of MSDS, or are unable to get access to the GEMS mainframe, contact your field EHS person for your zone, or contact the MR Phantom Lab at (414)-521-6494.

Phantom List by Solution

CuSO₄ (copper sulfate)

MSDS 8363922

46-265622G1 1.0/1.5T 20L Carboy
46-258559G1 Coronal/Sagittal
46-258582G1 Full Field Distortion

46-287325G1 Surface Coil Axial Slab
46-287379G1 Head Axial
46-271279G1 Quad Phase
46-265826G5 Head TLT Sphere
46-265635G5 Body TLT Sphere
46-282978G1 DQA Contrast Vials (Labelled A,B,C inside the DQA)
46-287780G1 Teledyne Ampules
46-287780G3 Teledyne Ampules
46-320830G1 Grafidy Vials

MSDS 8363705

46-265635G2 T2 Body Sphere

NiCl₂ (nickel chloride)**MSDS 8363917**

46-317776g1 DQA III
46-265826G6 Head TLT Sphere
46-265635G6 Body TLT Sphere
46-317586G1 100mm Sphere
46-317604G1 TMJ Phantom
46-317605G1 CTL Phantom
46-317626G1 P/U Phantom
46-328501G1 DQA
46-287780G2 Teledyne Ampules
46-328480G1 Surface Coil Kit
46-265622G2 0.5T 20L Carboy
P9300VD 50L Carboy
2125244 Short Loader

NiCl₂ and NaCl (nickel chloride and sodium chloride)**MSDS 3363917**

46-282280G1 W100 Phantom

Manganese chloride, potassium sorbate, sodium chloride, and glycerin**MSDS 8363919**

46-287902G1 Body Loader
46-287902G2 Body Loader

Manganese chloride, potassium sorbate, sodium chloride**MSDS 8363918**

46-287899G1 Head Loader
2138299 Short Loader

Manganese chloride and potassium sorbate

MSDS 8363916

46-265826G3 Head SNR Sphere
46-265826G4 Body SNR Sphere

Manganese chloride and sodium chloride

MSDS 8363921

46-287236G1 5x11" Surface Coil Load
46-287237G1 5.5" GP Surface Coil Load
46-287236G2 5.5" Circular Back Surface Coil Load
46-287238G1 5x11" Ear Surface Coil Load

Glycerin, sodium chloride, and sodium hypochlorite

MSDS 8363920

46-282978G1 DQA (if the small bottles labelled A,B,C are leaking , see MSDS 8363922)

Phosphoric Acid

MSDS 8360515

46-317299G1 Spectro Phantom
46-317299G2 Spectro Phantom
46-320368G1 Teledyne Ampules

Copper Sulfate

MSDS 8363705

2138298 SPT LV Shim

REVISION HISTORY

REV	DATE	AUTHOR	PRIMARY REASONS FOR CHANGE
0	August 5, 1998	M. Whitlow	Initial conversion from Toolbook to Word.