

# TABLE OF CONTENTS

**TABLE OF CONTENTS** ..... 1

**1- OVERVIEW** ..... 2

**2- TOOLS AND INSTRUMENTS REQUIRED** ..... 4

**3- INITIAL CONDITIONS** ..... 5

    3-1 Pre-requisite Status ..... 5

**4- INITIAL HARDWARE PREPARATION** ..... 6

**5- HEAD HARDWARE SETUP AND CHECKS** ..... 8

**6- BODY CHECKS** ..... 16

**7- AMPLIFIER SHUTDOWN VERIFICATION** ..... 25

**8- SYSTEM RESTORATION** ..... 28

**9- DECLARATION FORM PREPARATION** ..... 29

**APPENDIX A — SIGNA POWER MONITOR FUNCTIONAL TEST DECLARATION FORM** ..... 30

**APPENDIX B — ALTERNATE EQUIPMENT SETUPS & NON-SERVICE PROTOCOLS** ..... 31

**APPENDIX C — MISCELLANIOUS RF CONVERSIONS AND FORMULAS** ..... 34

    RF Conversion Formulas ..... 34

**APPENDIX D — DUMMY LOAD AND CABLES CALIBRATION** ..... 35

    E-1 Overview ..... 35

    D-2 Tools and Instruments Required ..... 36

    D-3 Initial Setup ..... 36

    D-4 Data Collection ..... 39

    D-5 Analysis ..... 42

    D-6 Calculation of RF power ..... 43

    D-7 System Restoration ..... 44

    D-8 Wattmeter Trivia ..... 45

    D-9 Scope Trivia ..... 46

**REVISION HISTORY** ..... 48

## 1- OVERVIEW

This section applies to systems installed with the 0.7T RF/PDU (GRFD) Cabinet (contains the RFI, SSM, RF amplifier, gradients, and PDU).

Use this procedure to ensure that the power monitors are fully functional, including redundant trip capability. The tests described use a special PSD (pulse sequence data base) to provide excitation for the RF amplifier. The PSD allows the service engineer to selectively force peak power, pulse width, and duty cycle beyond allowable limits. Select set points for testing by modifying Control Variables that override the values normally calculated and downloaded by the PSD.

Power Monitor firmware operation is changed to bypass/test mode by moving “monitor” switches (A and B) on the front of the SSM. This action permits set-point verification without tripping the RF amplifier, thereby eliminating the time consuming necessity of resetting the amplifier after each trip. It is necessary to measure the RF output power and know at what level each monitor tripped.

Three methods are available and listed in the order of preference for measuring head and body RF output power:

- **RF Power Measurement Kit** - Easy to use, preferred method of power measurement.
- **Bird wattmeter** - Must account for cable and load loss to determine actual power.
- **Oscilloscope** - Must account for cable and dummy load loss to accurately calculate the power from the observed peak voltage. This method works but the process used to derive the power is somewhat complex and lacks the accuracy of the previous two methods. It is, for this reason, not recommended.

It is *strongly recommended* that the RF Power Measurement Kit be used to obtain an accurate measurement of the RF output power. If it is not possible to obtain an RF Power Measurement Kit then one of the two other methods can be used provided that:

- The Dummy Load and Cables Calibration procedure in Appendix D has been performed and the individual loss values are known.



**WARNING!**

**FAILURE TO ACCOUNT FOR THE ACTUAL LOSSES IN THE DUMMY LOAD AND CABLES WHEN NOT USING THE RF POWER MEASUREMENT KIT TO MEASURE RF POWER CAN RESULT IN SIGNIFICANT MEASUREMENT ERRORS.**

After checking the set points, the actual shutdown of the amplifier is verified: once for monitor A, once for monitor B, and once for the HV relay shutdown. The actual shutdown of the amplifier is verified twice for monitor A (to verify both relay and logic shutdowns), and once for monitor B (connected to amplifier via monitor A). This also confirms that the bypass/test “monitor” switches (A and B) are restored prior to returning the system to normal operation.

A Calibration Flowchart has been provided in Illustration 1-1.

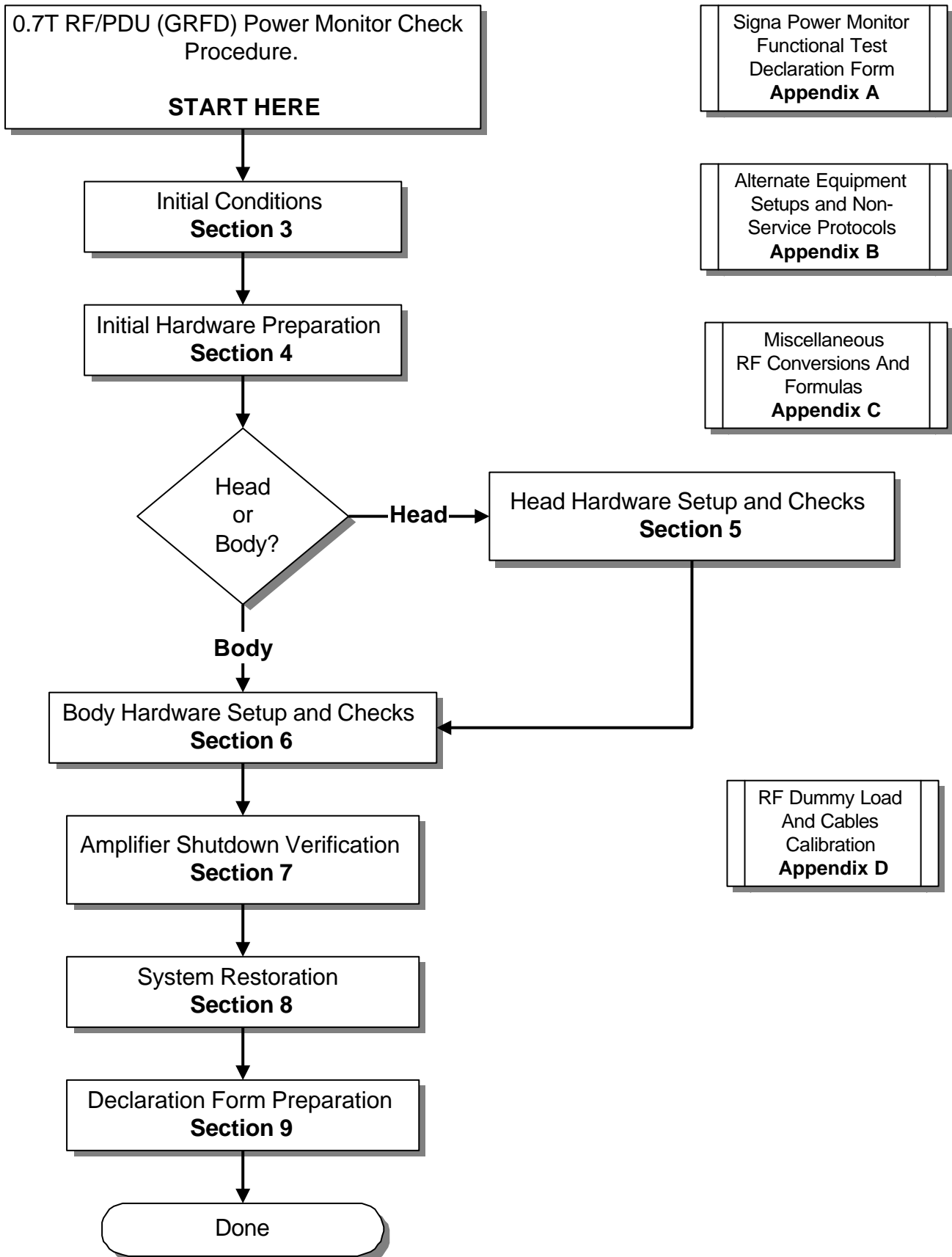

POWER MONITOR CHECK FLOWCHART  
ILLUSTRATION 1-1

**2- TOOLS AND INSTRUMENTS REQUIRED**

Table 2-1 describes what tools are necessary if the RF Power Measurement Kit is NOT used. Table 2-2 describes all the necessary tools needed if the RF Power Measurement Kit is used.

The use of the RF Power Measurement Kit to complete the RF Power Monitor Check is highly recommended.

TABLE 2-1  
**TOOLS AND INSTRUMENTS REQUIRED WITHOUT RF POWER MEASUREMENT KIT**

Item	Description	Part Number
1.	RF Test Cables Kit	46-255816G1
2.	50 ohm, 200 Watt, 30 dB attenuator - Bird Model 8322	46-255837P10
3.	Oscilloscope	46-183029P61
4.	Wattmeter and appropriate elements (optional)	Not supplied

TABLE 2-2  
**TOOLS AND INSTRUMENTS REQUIRED WITH RF POWER MEASUREMENT KIT**

Item	Description	Part Number
1.	RF Power Measurement Kit	46-317724G1 or G2
2.	50 ohm, 200 Watt, 30 dB attenuator - Bird Model 8322 <b>NOTE:</b> Only required with G1 Kit	46-255837P10
3.	Oscilloscope	46-183029P61

**3- INITIAL CONDITIONS**

Perform the prerequisite calibration procedures in the sequence listed in Table 3-1.

TABLE 3-1  
**PRE — REQUISITE PROCEDURES**

Step	Procedure Title	When Required
1	Dummy Load & Cables Calibration (Do ONLY if not using the RF Power Measurement Kit)	Calibration required whenever using the dummy load and cables. This value will be frequency specific and can change over time.
2	RF/PDU Max Power RF Out Setup and Calibration	At initial installation or if the RFI, UCERD Exciter, or RF Amps have been repaired or replaced.



**POSSIBLE EQUIPMENT DAMAGE. ENSURE THAT THE RF AMPLIFIER HAS A DUMMY LOAD CONNECTED TO ITS OUTPUT BEFORE INITIATING TESTS. IF NOT, FAULTS MAY OCCUR AND RF AMPLIFIER COMPONENTS COULD BE PERMANENTLY DAMAGED.**

**3-1 Pre-requisite Status**

**Pre-requisite** — Signa must be fully functional and properly calibrated.

**Pre-requisite** — Software must be running with the system capable of normal imaging.

#### 4- INITIAL HARDWARE PREPARATION

1. Verify that the system is not scanning and that all coils have been removed from the magnet bore. See the **DANGER** message on this page.



**PROPERTY DAMAGE! TO PREVENT COIL AND ASSOCIATED SWITCH DAMAGE, REMOVE ALL PHANTOMS AND HARDWARE (I.E., HEAD COIL, SURFACE COIL...) FROM THE MAGNET BORE.**

2. Remove the front door from the RF/PDU Cabinet.
3. See Illustration 4-1. On the front of the SSM place the:
  - 2 (two) power MONITOR switches (A and B) to the middle BYPASS position.
  - 3 (three) DRV FLT switches to the bottom DIS (disable faults) position.

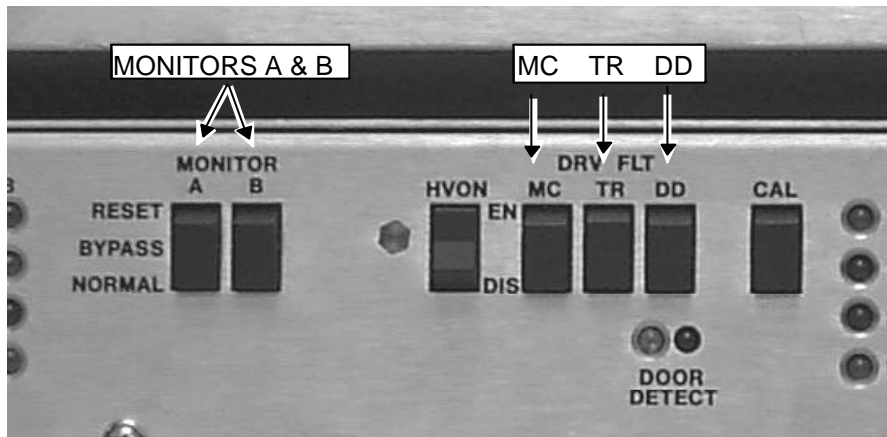

SSM FRONT PANEL SWITCHES DISABLED  
ILLUSTRATION 4-1

6. Remove the test window from the Test Switches and Test LEDs on the front of the SSM. See Illustration 4-2

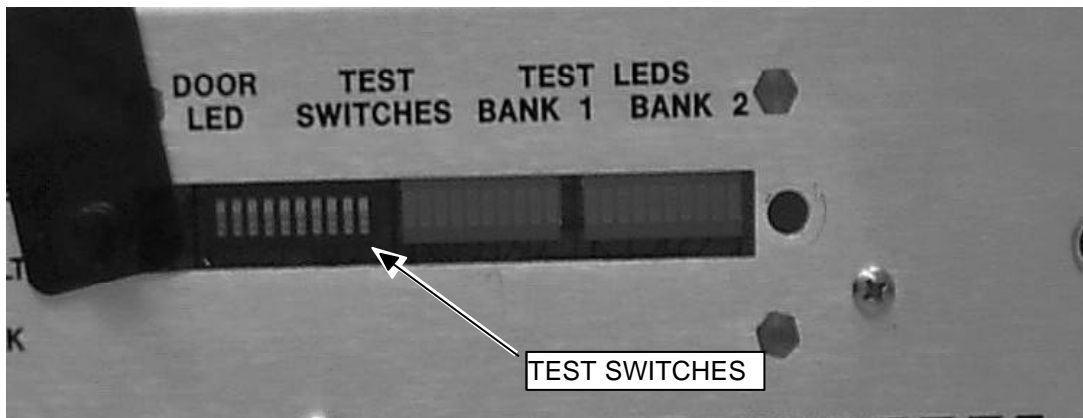

INSIDE THE TEST WINDOW  
ILLUSTRATION 4-2

**Note**

Order of DIP switch placement is important otherwise the system will not recognize changes.

- 7. Place the first four switches in the order and positions shown in Table 4-1 or use the alternate proprietary procedure.

TABLE 4-1  
**SWITCH POSITIONS**

<b>SWITCH NUMBER</b>	<b>POSITION</b>
2	UP
3	DOWN
4	UP
1	UP

- 8. The TEST LED will illuminate.

## 5- HEAD HARDWARE SETUP AND CHECKS

1. If you are not using the RF Power Measurement Kit then complete the Dummy Load and Cables Calibration procedure in Appendix D.



**PERSONAL INJURY! PREVENT POSSIBLE RF BURNS WHEN DISCONNECTING HELIAX CABLES FROM J3 OR J4 ON THE RFI BY VERIFYING THAT THE SYSTEM IS NOT MANUALLY PRESCANNING OR SCANNING. VERIFY THAT THE SCAN DESKTOP ICON DISPLAYS THE "IDLE" MESSAGE.**



2. Connect the system as shown on the Head Output RF Power Measurement Kit Card # 58 (750W, 58dBm) or refer to Appendix B (Alternate Equipment Setup) if using the wattmeter or the scope.

### Note

The head RF output connection is no longer to the non-existent EFB unit, as the reference cards in some of the older kits show, but instead to the J3 output on the rear of the RFI.

3. At operator work space, select the scan desktop ICON in the desktop control panel, if you have not already done so.
4. At the operator work space, prepare the system for a Head Power Monitor scan using the "Service Protocols" procedure in Table 5-1 below. Refer to Appendix B for the non-proprietary protocol.

TABLE 5-1  
SCAN PRESCRIPTION - HEAD PM CHECKS

Note: This is the alternate proprietary procedure available for GE use, and to sites with a valid Advanced Service Package Limited License. Refer to Appendix B for the non-proprietary protocol.

- [New Pt]**  
Id: **geservice** <ENTER>  
Name: **pmc**  
Weight (Lb.): **300**  
Set Patient Protocols to **Service**.
- At front enclosure:  
Landmark in the Head area—remove all coils.  
press **LANDMARK**.  
press **MOVE TO SCAN**.
- At Patient Protocols – select **other**.
- In the protocol field, type **o.23.1**<ENTER> (o=Other, 23.1 =series) to load the head protocol  
**OR** select [**o.23**] [**Series 1**] [**Accept**].  
**[OK]** (if required).
- [Save Series]**.
- [Prepare to Scan]**.

G. **[Research Operations]**.  
**[Setup Params]**. Set **TG** to **50**. **[Done]**.  
H. **[Research Operations]**.

10. Refer to Table 5-3. Note that the table consists of 5 columns (**Test, Scan Conditions, Adjustments, Verify, Conclusions**) and 10 individual rows of various head power tests.

**Note**

It may be advantageous at this point to print a hard copy of Table 5-3. This will provide a quick reference and also a place for making notations.

- 11. Start at the first **Test** row in Table 5-3. Under the **Scan Conditions** column highlight or type-in the CVs into the CV Name box and then enter the listed corresponding number into the Current Value box. Right mouse-click on the remaining items listed in the column.
- 12. Advance to the **Adjustments** column on the right and perform the directions listed in the column. Refer to steps 8 (RF Power Measurement Kit), 13 (wattmeter method), or 14 (oscilloscope method) for measuring the RF Power as directed by the instructions in the **Adjustments** column.
- 13. **If using the RF Power Measurement Kit:** Refer to the RF Power Measurement Kit reference card # 58 calibration sticker (1.0T Head RF Output). Otherwise, skip ahead to steps 22 or 23.
- 14. Note the Scope Power and Scope Rdg values from the calibration sticker on the reference card. The example below shows what information is on the card.

1.0T HEAD CARD # 58 CALIBRATION STICKER DATA
A. Card Number 46-317724P32
Nominal: 58.75 dBm
Attenuation: -55.43 dB
<b>Scope Power:</b> 3.32 dBm
<b>Scope Rdg:</b> 0.927 Vpp

- 15. Measure the amplitude of the RF waveform from the scope face in volts peak (Vp).
- 16. Mouse click on the **ToolBelt Icon** and then **[Utilities]**, **[RF Calculator]**, **[Start]**.

17. Use the RF Calculator program to determine the power output from the amplifier. Enter the actual reference and measured values in place of the sample values in the example below.

(Q)uick RF Calculator  
 (R)F Calculator

Enter selection: (Q,R) [Q] :R

RF Power Calculator

- 1) Watts to dBm
- 2) dBm to Watts
- 3) Scope relative voltage from relative power (Watts)
- 4) Scope relative voltage from relative power (dBm)
- 5) Scope relative power from relative voltage (Watts)
- 6) Scope relative power from relative voltage (dBm)
- 7) Quit

Enter selection: (1..7) [5] : 6

\*\*\*\*\* NOTE: Constant attenuation is assumed! \*\*\*\*\*

Enter reference power in dBm: (0.0..1000.00) [10.00] : **3.32** ← Scope Power *from card*.

Enter reference Volts peak: (0.0..100.00) [8.00] : **0.4635** ← Scope Rdg *from card* divided by 2.

Enter measured volts peak: (0.0..100.00) [8.00] : **0.2129** ← **Peak voltage** measured from scope.

Measured power is **-3.43 dBm** ← **This is the power observed at the scope. Please record this number in the Measured Power column in Table 5-2.**

Press ENTER to continue [ ] : <Enter>

RF Power Calculator

- 1) Watts to dBm
- 2) dBm to Watts
- 3) Scope relative voltage from relative power (Watts)
- 4) Scope relative voltage from relative power (dBm)
- 5) Scope relative power from relative voltage (Watts)
- 6) Scope relative power from relative voltage (dBm)
- 7) Quit

Enter selection: (1..7) [5] : *Don't exit yet as you will use tool # 6 repeatedly to complete the power monitor check.*

18. Note the measured power at the scope (in **dBm**) calculated by the RF Calculator program. Record this number in the Measured Power column in Table 5-2. Be sure to include the polarity of the number.

19. Note the Attenuation value (in **dBm**) from the calibration sticker. This will be a negative number. Record this number in the Attenuation (in dBm) column in Table 5-2. Be sure to include the polarity of the number.
20. Refer to Table 5-2 and subtract the Attenuation value from the Measured Power value. Please be sure to mind the polarity signs of the numbers. **This is critical.** Record the resulting value (in dBm) in the column labeled "RFI Output". See the example in the first row of Table 5-2.

TABLE 5-2  
RFI RF OUTPUT CALCULATION

<b>Check</b>	<b>Measured Power (in dBm)</b>  (Calculated from RF Tool)	<b>Attenuation (in dBm)</b>  (From calibration sticker)	<b>RFI Output (in dBm)</b>
<b>Example Only</b>	<b>- 3.43dBm</b> (from above RF Calculator)	<b>- 55.43dBm</b> (from above cal sticker)	<b>- 3.43 – (- 55.43) = <u>52.00 dBm</u></b>
<b>1</b>	_____dBm	_____dBm	Measured Power – Attenuation = _____dBm
<b>2</b>	_____dBm	_____dBm	Measured Power – Attenuation = _____dBm
<b>3</b>	_____dBm	_____dBm	Measured Power – Attenuation = _____dBm
<b>4</b>	_____dBm	_____dBm	Measured Power – Attenuation = _____dBm
<b>5</b>	_____dBm	_____dBm	Measured Power – Attenuation = _____dBm

21. Use the value recorded in the RFI Output column to compare to the values (in dBm) in the **Verify** column of Table 5-3.



**THE RFI OUTPUT VALUE RECORDED IN TABLE 5-2 IS EXPRESSED IN dBm. THE VALUES IN THE VERIFY COLUMN OF TABLE 5-3 ARE EXPRESSED IN BOTH dBm AND WATTS. COMPARE THE RFI OUTPUT (IN dBm) ONLY TO THE VALUES EXPRESSED IN dBm. DO NOT ATTEMPT TO DIRECTLY COMPARE THE RFI OUTPUT WITH A VALUE EXPRESSED IN WATTS WITHOUT CONVERTING ONE OF THE TWO VALUES SO THAT BOTH ARE EXPRESSED IN THE SAME UNIT OF MEASUREMENT. SEE APPENDIX C, IF NECESSARY, FOR CONVERSION INFORMATION.**

22. **If using the wattmeter procedure:** Read the wattmeter display and use the formula below to calculate the head RF power. Note that the cable loss factor was determined from the procedure in Appendix D. Record the calculated power. This will be compared to the values expressed in Watts in the **Verify** column. Continue with the Table instructions.

<b>RF Power Measurement (in watts) Using Wattmeter And Formula:</b>
Wattmeter reading (in watts) <b>X</b> cable loss factor

23. **If using the oscilloscope:** Read the peak voltage (V<sub>peak</sub>) from the scope display and use the formula below to calculate the head RF power. Note that the dummy load and cable loss factor was determined from the procedure in Appendix D. This will be compared to the values expressed in Watts in the **Verify** column. Continue with the Table instructions.

<b>RF Power Measurement (in watts) Using Oscilloscope And Formula:</b>
$\frac{(V_{peak})^2}{100}$ <b>X</b> dummy load and cable loss factor

24. When all measurements have been completed then reference the specified limits in the **Verify** column and record the PASS/FAIL status of the test.
25. Perform the steps in **Conclusion** column and then proceed to the next row and repeat the process again. Continue this until all the tests listed in Table 5-3 have been completed.

**Note**

Allow at least 12 seconds after looping starts before checking status of FAULT LEDs.

**Note**

It is possible that the system may report a PSD Download failure when calmode 2 is used. If this happens then change the calmode from 2 to 5. Measure the peak voltage of the 2<sup>nd</sup> pulse (180 degree pulse) when calmode = 5. This will be fixed on a subsequent software release.

TABLE 5-3  
HEAD CHECKS (0.7T) HFO

Test	Scan Conditions	Adjustments (Note 1)	Verify	Conclusion
HEAD PEAK POWER <i>high</i>	[Modify CVs] calmode = 2 trig = 7 aset = 50 [Accept] [Research Operations] [Download] [Manual Prescan]	Increase Transmit Gain (TG) until laptop or SSM LED indicates fault occurred on one of the monitors; measure Power.  Continue increasing TG until laptop or SSM LED indicates other monitor has faulted; measure Power.	Power is within specifications: Min: 160 W or 52 dBm Max: 240 W or 53.8 dBm Nom: 200 W or 53 dBm <input type="checkbox"/> Pass <input type="checkbox"/> Fail	Set TG to 0. [Done].  Place both Monitor A and B switches to <b>RESET</b> , then <b>BYPASS</b> .  On laptop, press 'C' to continue.
HEAD PEAK POWER <i>LOW</i>	[Modify CVs] aset = 30 [Accept] [Research Operations] [Download] [Manual Prescan]	Increase Transmit Gain (TG) until laptop or SSM LED indicates fault occurred on one of the monitors; measure Power.  Continue increasing TG until laptop or SSM LED indicates other monitor has faulted; measure Power.	Power is within specifications: Min: 100 W or 50 dBm Max: 136 W or 51.34 dBm Nom: 117 W or 50.7 dBm <input type="checkbox"/> Pass <input type="checkbox"/> Fail	Set TG to 0. [Done].  Place both Monitor A and B switches to <b>RESET</b> , then <b>BYPASS</b> .  On laptop, press 'C' to continue.

TABLE 5-3  
HEAD CHECKS (0.7T) HFO (CONTINUED)

HEAD PULSE WIDTH (PW) <i>high</i> (min Limit)	[Modify CVs] calmode = 1 p1 = <b>7823</b> aset = <b>255</b> pwset = <b>35</b> [Accept] [Download] [Manual Prescan]	Increase TG (from 0) until Power measures 50W (46.9 dBm) to 70W (48.45 dBm). (Note 2)	SENSE LEDs on SSM are ON HEAD LED on RFI is ON FAULT LEDs (both OFF) <input type="checkbox"/> Pass <input type="checkbox"/> Fail	[Done].
<b>Note 2:</b> If necessary, increase TG until SENSE LEDs come on. No more than 100 W (50.00 dBm) should be necessary.				
HEAD PW <i>High</i> (Max Limit)	[Modify CVs] p1 = <b>8647</b> [Accept] [Research Operations] [Download] [Manual Prescan]	Do not change TG.	FAULT LEDs (both ON) <input type="checkbox"/> Pass <input type="checkbox"/> Fail	[Done], Place both Monitor A and B switches to <b>RESET</b> , then <b>BYPASS</b> . On laptop, press 'C' to continue.
HEAD PW <i>LOW</i> (Min Limit)	[Modify CVs] p1 = <b>1076</b> pwset = <b>5</b> [Accept] [Research Operations] [Download] [Manual Prescan]	Do not change TG.	SENSE LEDs on SSM are ON HEAD LED on RFI is ON FAULT LEDs (both OFF) <input type="checkbox"/> Pass <input type="checkbox"/> Fail	[Done]
HEAD PW <i>LOW</i> (Max Limit)	[Modify CVs] p1 = <b>1276</b> [Accept] [Research Operations] [Download] [Manual Prescan]	Do not change TG.	FAULT LEDs (both ON) <input type="checkbox"/> Pass <input type="checkbox"/> Fail	[Done], Place both Monitor A and B switches to <b>RESET</b> , then <b>BYPASS</b> . On laptop, press 'C' to continue.

TABLE 5-3  
HEAD CHECKS (0.7T) HFO (CONTINUED)

<p>HEAD DUTY CYCLE (DC) HIGH CYCLE (DC) (Min Limit)</p>	<p><b>[Modify CVs]</b> t3 = <b>33333</b> TR_SLOP = <b>0</b> calmode = <b>3</b> p3 = <b>3900</b> pwset = <b>255</b> dcset = <b>130</b> <b>[Accept]</b> <b>[Research Operations]</b> <b>[Download]</b> <b>[Manual Prescan]</b></p>	<p>Do not change TG.</p>	<p>SENSE LEDs on SSM are ON HEAD LED on RFI is ON FAULT LEDs (both OFF) (Note 3) <input type="checkbox"/> Pass <input type="checkbox"/> Fail</p>	<p><b>[Done].</b></p>
<p>HEAD DC <i>High</i> (Max limit)</p>	<p><b>[Modify CVs]</b> p3 = <b>4767</b> <b>[Accept]</b> <b>[Research Operations]</b> <b>[Download]</b> <b>[Manual Prescan]</b></p>	<p>Do not change TG.</p>	<p>FAULT LEDs (both ON) (Note 3) <input type="checkbox"/> Pass <input type="checkbox"/> Fail</p>	<p><b>[Done],</b> Place both Monitor A and B switches to <b>RESET</b>, then <b>BYPASS</b>. On laptop, press 'C' to continue.</p>
<p>HEAD DC <i>LOW</i> (Min Limit)</p>	<p><b>[Modify CVs]</b> p3 = <b>750</b> dcset = <b>25</b> <b>[Accept]</b> <b>[Research Operations]</b> <b>[Download]</b> <b>[Manual Prescan]</b></p>	<p>Do not change TG.</p>	<p>SENSE LEDs on SSM are ON HEAD LED on RFI is ON FAULT LEDs (both OFF) (Note 3) <input type="checkbox"/> Pass <input type="checkbox"/> Fail</p>	<p><b>[Done].</b></p>
<p>HEAD DC <i>LOW</i> (Max Limit)</p>	<p><b>[Modify CVs]</b> p3 = <b>917</b> <b>[Accept]</b> <b>[Research Operations]</b> <b>[Download]</b> <b>[Manual Prescan]</b></p>	<p>Do not change TG.</p>	<p>FAULT LEDs (both ON) (Note 3) <input type="checkbox"/> Pass <input type="checkbox"/> Fail</p>	<p><b>[Done],</b> Place both Monitor A and B switches to <b>RESET</b>, then <b>NORMAL</b>. On laptop, press 'C' to continue.</p>

## 6- BODY CHECKS

Tests in this section allow the service engineer to selectively force body mode peak power, pulse width, and duty cycle beyond allowable limits.



**PROPERTY DAMAGE! PREVENT COIL AND ASSOCIATED SWITCH DAMAGE, BY REMOVING ALL PHANTOMS AND HARDWARE (I.E., HEAD COIL, SURFACE COIL...) FROM THE MAGNET BORE.**

1. Confirm that all the steps in Section 4 - Initial Hardware Preparation - have been done.
2. Verify that the system is not scanning and that all coils have been removed from the magnet bore. See the two **DANGER** messages on this page.
3. If you are not using the RF Power Measurement Kit then refer to the procedure in Appendix D and characterize the dummy load and cables. If these values were already determined in Section 5 then the same values can be used in this section and it is not necessary to reference Appendix D again.



**PERSONAL INJURY! PREVENT POSSIBLE RF BURNS WHEN DISCONNECTING HELIAX CABLES FROM J3 OR J4 ON THE RFI BY VERIFYING THAT THE SYSTEM IS NOT MANUALLY PRESCANNING OR SCANNING. VERIFY THAT THE SCAN DESKTOP ICON DISPLAYS THE "IDLE" MESSAGE.**



4. Connect the system as shown on the Body Output RF Power Measurement Kit Card # 68.8 (7.58kW, 68.8dBm) or refer to Appendix B (Alternate Equipment Setup) if using the wattmeter or scope.

### Note

The body RF output connection is no longer to the non-existent EFB unit, as the older reference cards from the kit show, but instead to the J4 output on the rear of the RFI. An RF adapter is provided in the RF Power Measurement Kit to connect between the HN J4 body RF output and the RF Power Measurement Kit 40 dB N-connector coupler.

5. At operator work space, select the scan desktop ICON in the desktop control panel, if you have not already done so.
6. At the operator work space, prepare the system for a Body Power Monitor scan using the "Service Protocols" procedure in Table 6-1 below. Refer to Appendix B for the non-proprietary protocol.

TABLE 6-1  
SCAN PRESCRIPTION - BODY PM CHECKS

Note: This is the alternate proprietary procedure available for GE use, and to sites with a valid Advanced Service Package Limited License. Refer to Appendix B for the non-proprietary protocol.

- A. **[New Series]**  
At Patient Protocols – select **other**.
- B. In the protocol field, type **o.23.2<ENTER>** (o=Other, 23.2 =series) to load the body protocol  
**OR** select **[o.23] [Series 2] [Accept]**.  
**[OK]** (if required).
- C. **[Save Series]**.
- D. **[Prepare to Scan]**.
- E. **[Research Operations]**.  
**[Setup Params]**. Set **TG** to **50**. **[Done]**.
- F. **[Research Operations]**.  
**[Display CVs]**. Highlight CV Name and enter the following:  
CV name: **dcset <ENTER>, 255 <ENTER>**  
CV name: **t3 <ENTER>, 20000 <ENTER>**  
**[Accept]**.
- F. **[Research Operations]**

7. Refer to Table 6-3. Note that the table consists of 5 columns (**Test, Scan Conditions, Adjustments, Verify, Conclusions**) and 10 individual rows of various head power tests.

**Note**

It may be advantageous at this point to print a hard copy of Table 6-3. This will provide a quick reference and also a place for making notations.

- 8. Start at the first **Test** row in Table 6-3. Under the **Scan Conditions** column highlight or type-in the CVs into the CV Name box and then enter the listed corresponding number into the Current Value box. Right mouse-click on the remaining items listed in the column.
- 9. Advance to the **Adjustments** column on the right and perform the directions listed in the column. Refer to steps 10 (RF Power Measurement Kit), 15 (wattmeter method), or 16 (oscilloscope method) for measuring the RF Power as directed by the instructions in the **Adjustments** column.
- 10. **If using the RF Power Measurement Kit:** Refer to the RF Power Measurement Kit reference card # 68.8 calibration sticker (1.0T Body RF Output). Otherwise, skip ahead to steps 19 or 20.
- 11. Note the Scope Power and Scope Rdg values from the calibration sticker on the reference card. The example below shows what information is on the card.

1.0T BODY CARD # 68.8 CALIBRATION STICKER DATA
Card Number 46-317724P33
Nominal: 68.80 dBm
Attenuation: -65.41 dB
Scope Power: 3.39 dBm
Scope Rdg: 0.934 Vpp

12. Measure the amplitude of the RF waveform from the scope face in volts peak (Vp).
13. Mouse click on the **ToolBelt Icon** and then [**Utilities**], [**RF Calculator**], [**Start**].

14. Use the RF Calculator program to determine the power output from the amplifier. Enter the actual reference and measured values in place of the sample values in the example below.

(Q)uick RF Calculator  
 (R)F Calculator

Enter selection: (Q,R) [Q] :R

RF Power Calculator

- 1) Watts to dBm
- 2) dBm to Watts
- 3) Scope relative voltage from relative power (Watts)
- 4) Scope relative voltage from relative power (dBm)
- 5) Scope relative power from relative voltage (Watts)
- 6) Scope relative power from relative voltage (dBm)
- 7) Quit

Enter selection: (1..7) [5] : 6

\*\*\*\*\* NOTE: Constant attenuation is assumed! \*\*\*\*\*

Enter reference power in dBm: (0.0..1000.00) [10.00] : **3.39** ← Scope Power *from card*.

Enter reference Volts peak: (0.0..100.00) [8.00] : **0.467** ← Scope R<sub>dg</sub> *from card* divided by 2.

Enter measured volts peak: (0.0..100.00) [8.00] : **0.351** ← **Peak** voltage measured from scope.

Measured power is **0.910 dBm** ← **This is the power observed at the scope. Please record this number in the Measured Power column in Table 5-2.**

Press ENTER to continue [ ] : <Enter>

RF Power Calculator

- 1) Watts to dBm
- 2) dBm to Watts
- 3) Scope relative voltage from relative power (Watts)
- 4) Scope relative voltage from relative power (dBm)
- 5) Scope relative power from relative voltage (Watts)
- 6) Scope relative power from relative voltage (dBm)
- 7) Quit

Enter selection: (1..7) [5] : *Don't exit yet as you will use tool # 6 repeatedly to complete the power monitor check.*

15. Note the measured power at the scope (in **dBm**) calculated by the RF Calculator program. Record this number in the Measured Power column in Table 6-2. Be sure to include the polarity of the number.

16. Note the Attenuation value (in **dBm**) from the calibration sticker. This will be a negative number. Record this number in the Attenuation (in dBm) column in Table 6-2. Be sure to include the polarity of the number.
17. Refer to Table 6-2 and subtract the Attenuation value from the Measured Power value. Please be sure to mind the polarity signs of the numbers. **This is critical.** Record the resulting value (in dBm) in the column labeled "RFI Output". See the example in the first row of Table 6-2.

TABLE 6-2  
RFI RF OUTPUT CALCULATION

<u>Check</u>	<u>Measured Power (in dBm)</u>  (Calculated from RF Tool)	<u>Attenuation (in dBm)</u>  (From calibration sticker)	<u>RFI Output (in dBm)</u>
Example Only	<b>0.910dBm</b> (from above RF Calculator)	<b>- 65.41dBm</b> (from above cal sticker)	<b>0.910 – (- 65.41) = <u>66.32 dBm</u></b>
1	_____dBm	_____dBm	Measured Power – Attenuation = _____dBm
2	_____dBm	_____dBm	Measured Power – Attenuation = _____dBm
3	_____dBm	_____dBm	Measured Power – Attenuation = _____dBm
4	_____dBm	_____dBm	Measured Power – Attenuation = _____dBm
5	_____dBm	_____dBm	Measured Power – Attenuation = _____dBm

18. Use the value recorded in the RFI Output column to compare to the values (in dBm) in the **Verify** column of Table 6-3.



**THE RFI OUTPUT VALUE RECORDED IN TABLE 6-2 IS EXPRESSED IN dBm. THE VALUES IN THE VERIFY COLUMN OF TABLE 6-3 ARE EXPRESSED IN BOTH dBm AND WATTS. COMPARE THE RFI OUTPUT (IN dBm) ONLY TO THE VALUES EXPRESSED IN dBm. DO NOT ATTEMPT TO DIRECTLY COMPARE THE RFI OUTPUT WITH A VALUE EXPRESSED IN WATTS WITHOUT CONVERTING ONE OF THE TWO VALUES SO THAT BOTH ARE EXPRESSED IN THE SAME UNIT OF MEASUREMENT. SEE APPENDIX C, IF NECESSARY, FOR CONVERSION INFORMATION.**

19. **If using the wattmeter procedure:** Read the wattmeter display and use the formula below to calculate the body RF power. Note that the dummy load and cable loss factor was determined from the procedure in Appendix D. Record this calculated power and then continue with the Table instructions.

<b>RF Power Measurement (in watts) Using Wattmeter And Formula:</b>
Wattmeter reading (in watts) <b>X</b> dummy load and cable loss factor

20. **If using the oscilloscope:** Read the peak voltage (V<sub>peak</sub>) from the scope display and use the formula below to calculate the body RF power. Note that the dummy load and cable loss factor was determined from the procedure in Appendix D and the scope correction factor was determined in Appendix D. Record this calculated power and then continue with the Table instructions.

<b>RF Power Measurement (in watts) Using Oscilloscope And Formula:</b>
$\frac{(V_{\text{peak}})^2}{100} \text{ X dummy load and cable loss factor}$

21. When all measurements have been completed then reference the specified limits in the **Verify** column and record the PASS/FAIL status of the test.
22. Perform the steps in **Conclusion** column and then proceed to the next row and repeat the process again. Continue this until all the tests listed in the Table have been completed.

**Note**

Allow at least 12 seconds after looping starts before checking status of FAULT LEDs.

**Note**

It is possible that the system may report a PSD Download failure when calmode 2 is used. If this happens then change the calmode from 2 to 5. Measure the peak voltage of the 2<sup>nd</sup> pulse (180 degree pulse) when calmode = 5. This will be fixed on a subsequent software release.

TABLE 6-3  
BODY CHECKS (0.7T) HFO

Test	Scan Conditions	Adjustments (Note 1)	Verify	Conclusion
BODY PEAK POWER HIGH	[Display CVs] calmode = 2 trig = 7 aset = 110 [Accept] [Research Operations] [Download] [Manual Prescan]	Increase Transmit Gain (TG) until laptop or SSM LED indicates fault occurred on one of the monitors; measure and note Power.  Continue increasing TG until laptop or SSM LED indicates other monitor has faulted; measure and note Power.	Power is within specifications: Min: 4100W, 66.127dBm Max: 4500W, 66.53dBm Nom: 4300W, 66.33dBm <input type="checkbox"/> Pass <input type="checkbox"/> Fail	Set TG to 0. [Done]  Place both Monitor A and B switches to <b>RESET</b> , then <b>BYPASS</b> .  On laptop, press 'C' to continue.
BODY PEAK POWER LOW	[Display CVs] aset = 30 [Accept] [Research Operations] [Download] [Manual Prescan]	Increase Transmit Gain (TG) until laptop or SSM LED indicates fault occurred on one of the monitors; measure and note Power.  Continue increasing TG until laptop or SSM LED indicates other monitor has faulted; measure and note Power.	Power is within specifications: Min: 1100W, 60.41dBm Max:1300W, 61.14dBm Nom:1200W, 60.79dBm <input type="checkbox"/> Pass <input type="checkbox"/> Fail	Set TG = 0. [Done]  Place both Monitor A and B switches to <b>RESET</b> , then <b>BYPASS</b> .  On laptop, press 'C' to continue.

TABLE 6-2  
**BODY CHECKS (0.7T) HFO (CONTINUED)**

Test	Scan Conditions	Adjustments (Note 1)	Verify	Conclusion
BODY PULSE WIDTH (PW) HIGH (Min Limit)	<p><b>[Display CVs]</b>                      calmode = 1                      p1 = <b>7823</b>                      aset = <b>255</b>                      pwset = <b>35</b>  <b>[Accept]</b>  <b>[Research Operations]</b>  <b>[Download]</b>  <b>[Manual Prescan]</b></p>	Increase TG (from 0) until power measures 500W (56.99 dBm) to 700 W (58.45 dBm). (Note 2)	SENSE LEDs on SSM are ON, BODY LED on RFI is ON, FAULT LEDs (both OFF) <input type="checkbox"/> Pass <input type="checkbox"/> Fail	<b>[Done]</b>
<p><b>Note 2:</b> If necessary, increase TG until SENSE LEDs come on. No more than 1 kW (60.00 dBm) should be necessary.</p>				
BODY PW HIGH (Max Limit)	<p><b>[Display CVs]</b>                      p1 = <b>8647</b>  <b>[Accept]</b>  <b>[Research Operations]</b>  <b>[Download]</b>  <b>[Manual Prescan]</b></p>	Do not change TG.	FAULT LEDs (both ON) <input type="checkbox"/> Pass <input type="checkbox"/> Fail	<p><b>[Done]</b>                      Place both Monitor A and B switches to <b>RESET</b>, then <b>BYPASS</b>.                      On laptop, press 'C' to continue.</p>
BODY PW LOW (Min Limit)	<p><b>[Display CVs]</b>                      p1 = <b>1076</b>                      pwset = <b>5</b>  <b>[Accept]</b>  <b>[Research Operations]</b>  <b>[Download]</b>  <b>[Manual Prescan]</b></p>	Do not change TG.	SENSE LEDs on SSM are ON, BODY LED on RFI is ON, FAULT LEDs (both OFF) <input type="checkbox"/> Pass <input type="checkbox"/> Fail	<b>[Done]</b>
BODY PW LOW (Max Limit)	<p><b>[Display CVs]</b>                      p1 = <b>1276</b>  <b>[Accept]</b>  <b>[Research Operations]</b>  <b>[Download]</b>  <b>[Manual Prescan]</b></p>	Do not change TG.	FAULT LEDs (both ON) <input type="checkbox"/> Pass <input type="checkbox"/> Fail	<p><b>[Done]</b>                      Place both Monitor A and B switches to <b>RESET</b>, then <b>BYPASS</b>.                      On laptop, press 'C' to continue.</p>

TABLE 6-2  
**BODY CHECKS (0.7T) HFO (CONTINUED)**

BODY DUTY CYCLE (DC) <i>HIGH</i> (Min Limit)	<p><b>[Display CVs]</b>                  calmode = 3                  t3 = 33333                  TR_SLOP = 0                  p3 = 3900                  pwset = 255                  dcset = 130  <b>[Accept]</b>  <b>[Research Operations]</b>  <b>[Download]</b>  <b>[Manual Prescan]</b></p>	Do not change TG.	SENSE LEDs on SSM are ON, BODY LED on RFI is ON, FAULT LEDs (both OFF) (Note 3) <input type="checkbox"/> Pass <input type="checkbox"/> Fail	<p><b>[Done]</b></p>
BODY DC <i>HIGH</i> (Max Limit)	<p><b>[Display CVs]</b>                  p3 = 4767  <b>[Accept]</b>  <b>[Research Operations]</b>  <b>[Download]</b>  <b>[Manual Prescan]</b></p>	Do not change TG.	FAULT LEDs (both ON) (Note 3) <input type="checkbox"/> Pass <input type="checkbox"/> Fail	<p><b>[Done]</b>                  Place both Monitor A                  and B switches to  <b>RESET</b>,                  then <b>BYPASS</b>.                  On laptop, press 'C' to                  continue.</p>
BODY DC <i>LOW</i> (Min Limit)	<p><b>[Display CVs]</b>                  p3 = 750                  dcset = 25  <b>[Accept]</b>  <b>[Research Operations]</b>  <b>[Download]</b>  <b>[Manual Prescan]</b></p>	Do not change TG.	SENSE LEDs on SSM are ON, BODY LED on RFI is ON, FAULT LEDs (both OFF) (Note 3) <input type="checkbox"/> Pass <input type="checkbox"/> Fail	<p><b>[Done]</b></p>
BODY DC <i>LOW</i> (Max Limit)	<p><b>[Display CVs]</b>                  p3 = 917  <b>[Accept]</b>  <b>[Research Operations]</b>  <b>[Download]</b>  <b>[Manual Prescan]</b></p>	Do not change TG.	FAULT LEDs (both ON) (Note 3) <input type="checkbox"/> Pass <input type="checkbox"/> Fail	<p><b>[Done]</b>                  Place both Monitor A                  and B switches to  <b>RESET</b>,                  then <b>NORMAL</b>.                  On laptop, press 'C' to                  continue.</p>

## 7- AMPLIFIER SHUTDOWN VERIFICATION

Tests in this section verify that each power monitor is capable of shutting down the RF Amplifier independently of the other, and further verify both the logic and relay shutdowns for each channel. Setpoints are not checked in this section — this test is forcing a shutdown.

When one or both of the monitors is in bypass mode, the HV relay shutdown is disabled.

1. Disable power monitor B by placing the monitor B switch on the front panel of the SSM in the Bypass position.
2. At the operator work space, prepare the system for a Amp Shutdown Verification scan using the "Service Protocols" procedure in Table 7-1 below. Refer to the body protocol in Appendix B for the non-proprietary protocol.

### Note

Verify that the Head Coil has been removed from the patient table before continuing.

TABLE 7-1

### SCAN PRESCRIPTION - HIGH VOLTAGE RELAY SHUTDOWN — BODY MODE

Note: This is the alternate proprietary procedure available for GE use, and to sites with a valid Advanced Service Package Limited License.

A. **[New Series]**

At Patient Protocols – select **other**.

- B. In the protocol field, type **o.23.3<ENTER>** (o=Other, 23.3 =series) to load the body protocol  
**OR** select **[o.23] [Series 3] [Accept]**.

**[OK]** (if required).

C. **[Save Series]**

D. **[Prepare to Scan]**.

E. **[Research Operations]**.

**[Setup Params]**. Set **TG** to **0**. **[Done]**.

F. **[Research Operations]**.

**[Display CVs]**. Highlight CV Name and enter the following:

CV name: **trig <ENTER>, 1 <ENTER>**

CV name: **aset <ENTER>, 120 <ENTER>**

CV name: **calmode <ENTER>, 2 <ENTER>**

CV name: **pwset <ENTER>, 255 <ENTER>**

CV name: **dcset <ENTER>, 255 <ENTER>**

CV name: **p1 <ENTER>, 3100 <ENTER>**

CV name: **p3 <ENTER>, 2400 <ENTER>**

G. **[Research Operations] [Download]**.

H. **[Prepare to Scan]**.

I. Select **[Manual Prescan]**.

3. Increase TG until monitor A FAULT LED illuminates. Quickly verify the following:
  - The FAULT LED on for monitor A (resets automatically after two seconds).
  - RF amplifier is shutdown and displaying fault code 84 or 85 (IPER resets the amplifier 10 to 15 seconds after the power monitor fault clears, i.e., a few seconds after the Fault LED goes off on the amplifier). Software Message Log - Software will log an 84 or 85 fault in the message log.
  - Verify oscilloscope or Wattmeter (press FWD PEP then MAX) reads zero RF power.

**Note**

Do not perform any operations at the keyboard while In Place Error Recovery (IPER) is resetting the RF amplifier.

4. While waiting for the RF amplifier to recover, place monitor B in normal mode by placing the monitor B switch on the front panel of the SSM in the Normal position. Now both monitors A and B should be in normal mode.
5. After IPER has reset the RF amplifier, first decrease TG by 50 counts (5dB), then press START SCAN on the operator's console to initiate looping.
6. Increase TG until the FAULT LED for monitor A or B illuminates. Quickly verify the following:
  - FAULT LED on for monitor A or B (resets automatically after two seconds).
  - RF amplifier is shutdown and displaying fault code 84 or 85 (IPER resets the amplifier 10 to 15 seconds after the power monitor fault clears, i.e., a few seconds after the Fault LED goes off on the amplifier). Software Message Log - Software will log an 84 or 85 fault in the message log.
  - Verify oscilloscope or Wattmeter (press FWD PEP then MAX) reads zero RF power.

**Note**

Do not perform any operations at the keyboard while In Place Error Recovery (IPER) is resetting the RF amplifier.

7. While waiting for the amplifier to recover, disable power monitor A by placing the monitor A switch on the front panel of the SSM in the Bypass position.
8. After IPER has reset the RF amplifier, first decrease TG by 50 counts (5dB), then press START SCAN on the operator's console to initiate looping.

9. Increase TG until monitor B FAULT LED illuminates. Quickly verify the following:
  - FAULT LED on for monitor B (resets automatically after two seconds).
  - RF amplifier is shutdown and displaying fault code 84 or 85 (IPER resets the amplifier 10 to 15 seconds after the power monitor fault clears, i.e., a few seconds after the Fault LED goes off on the amplifier). Software Message Log - Software will log an 84 or 85 fault in the message log.
  - Verify oscilloscope or Wattmeter (press FWD PEP then MAX) reads zero RF power.

**Note**

Do not perform any operations at keyboard while In Place Error Recovery (IPER) is resetting the RF amplifier.

10. After IPER has reset the RF amplifier, select **[Done]**.
11. In the Rx Manager, select **[End Exam]**.
12. Proceed to Section 8 – System Restoration

**8- SYSTEM RESTORATION**

1. Refer to Illustration 8-1. At the front of the SSM place the:
  - 2 (two) power MONITOR switches (A and B) to the bottom NORMAL position.
  - 3 (three) DRV FLT switches to the top EN (enable faults) position.

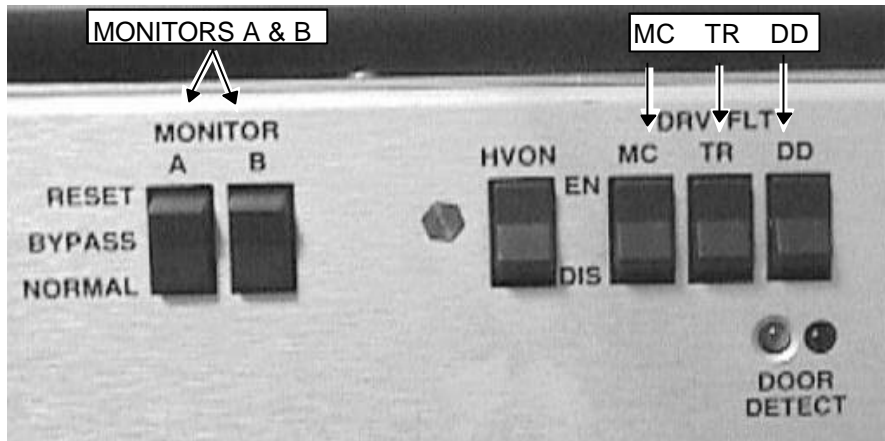

**FRONT PANEL SWITCHES ENABLED**

ILLUSTRATION 8-1

2. Place DIP switches 4, 3, 2, and 1 of the Test Switches in the DOWN position or disconnect laptop computer from J46 on the rear of the SSM.

**Note**

If using the Laptop perform the following steps to exit MONS.EXE and return to Windows:

- A) Follow screen directions to return to DOS.
- B) At the DOS C:\CCLASS\ERBTEC> prompt, type **EXIT<ENTER>**.

3. Ensure that the dummy load (all test equipment) is disconnected from the rear of the cabinet.
4. Ensure that the head and body Heliac cables are reconnected to the rear of the cabinet.
5. Complete one head scan satisfactorily.
6. Complete one body scan satisfactorily.
7. Replace the front door on the cabinet.

Prepare and file power monitor functional check data sheet according to current company policy. See Section 9 – Declaration Form Preparation.

**9- DECLARATION FORM PREPARATION**

1. Prepare Direction 2212504, *Signa Release 8.X RF/PDU 1.0T/1.5T Cabinet Power Monitor Functional Test Declaration Form, Appendix A*. Refer to procedure for Data Sheet for Power Monitor Test Declaration Form.
2. File completed declaration form per current company policy.

**APPENDIX A — SIGNA POWER MONITOR FUNCTIONAL TEST DECLARATION FORM**

**Signa Release 8.X RF/PDU 1.0T/1.5T CABINET  
 Power Monitor Functional Test Declaration**

**SITE**

\_\_\_\_\_  
 (NAME) (SYSTEM ID, ROOM NUMBER, ETC., IF APPLICABLE)

\_\_\_\_\_  
 (STREET) (SYSTEM CABINET SERIAL NUMBER)

\_\_\_\_\_  
 (CITY, STATE, ZIP CODE) (CURRENT SYSTEM SOFTWARE RELEASE)

**TEST EQUIPMENT**

\_\_\_\_\_  
 (BIRD WATTMETER SERIAL NO.) (OSCILLOSCOPE SERIAL NO.) (RF POWER MEASUREMENT KIT SERIAL NO.)

\_\_\_\_\_  
 (DUMMY LOAD PLUS CABLES ATTEN FACTOR) (AMP TO WATTMETER CABLE ATTEN FACTOR)

**PERFORMANCE**

FUNCTION CHECK STATUS	PASS
BODY PEAK POWER TEST	<input type="checkbox"/>
BODY PULSE WIDTH TEST	<input type="checkbox"/>
BODY DUTY CYCLE TEST	<input type="checkbox"/>
HEAD PEAK POWER TEST	<input type="checkbox"/>
HEAD PULSE WIDTH TEST	<input type="checkbox"/>
HEAD DUTY CYCLE TEST	<input type="checkbox"/>
SHUTDOWN VERIFICATION	<input type="checkbox"/>

CONFIGURATION FILE ENTRIES		
	Cable loss coefficient	Coil loss coefficient
Head Coil	_____	_____
Body Coil	_____	_____
AMP Cal Head	_____	ABSOLUTE AVG SAR _____
AMP Cal Body	_____	ABSOLUTE PEAK SAR _____
Average SAR Factor	_____	Peak SAR Factor _____

**RESTORATION CHECK LIST**

- On the front panel of the SSM, place the two monitor switches in the Normal position, and place the three DRV FLT switches in the enable faults position (EN).
- Ensure that the dummy load is disconnected from the rear of the cabinet.
- Ensure that the head and body Heliac cables are reconnected to the rear of the cabinet.
- Disconnect laptop computer from J46 on the rear of the SSM.
- Complete one head scan satisfactorily.
- Complete one body scan satisfactorily.
- Replace the front door on the cabinet.
- Prepare and file Direction 2212504, *Signa Horizon 5.X & 8.X RF/PDU 1.0T/1.5T Power Monitor Functional Test Declaration Form* according to company policy.

\_\_\_\_\_  
 (PERFORMED BY - PLEASE PRINT)

\_\_\_\_\_  
 (SIGNATURE)

\_\_\_\_\_  
 (DATE)

DIRECTION 2212504 REV 2 (March 16, 1999)

**APPENDIX B — ALTERNATE EQUIPMENT SETUPS & NON-SERVICE PROTOCOLS**

Use this section if the RF Power Measurement Kit is NOT going to be used. This section contains the setup information and protocols necessary to measure the body and head RF output power using either a wattmeter or oscilloscope.

TABLE B-1  
**TOOLS AND INSTRUMENTS REQUIRED WITHOUT RF POWER MEASUREMENT KIT**

<b>Item</b>	<b>Description</b>	<b>Part Number</b>
1.	RF Test Cables Kit	46-255816G1
2.	50 ohm, 200 Watt, 30 dB attenuator - Bird Model 8322	46-255837P10
3.	Oscilloscope	46-183029P61
4.	Laptop serial cable (optional)	2124497-46
4.	Wattmeter and appropriate elements (optional)	Not supplied

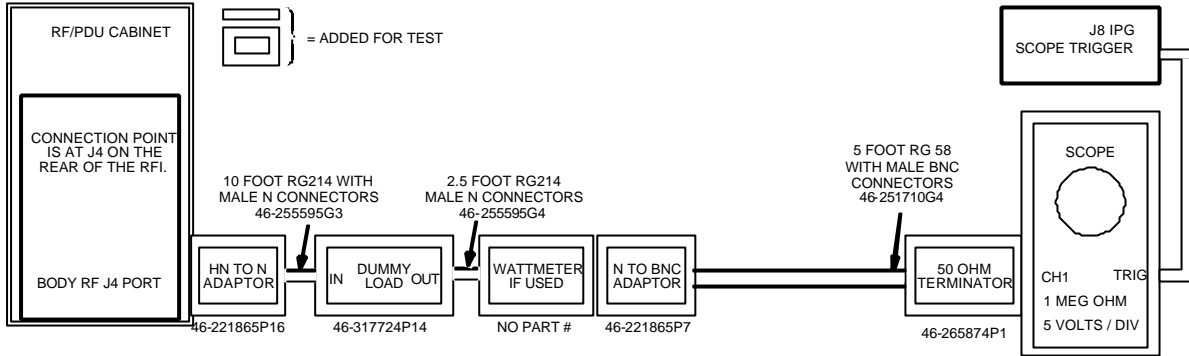

ALTERNATE BODY EQUIPMENT SETUP FOR WATTMETER OR SCOPE MEASUREMENT  
ILLUSTRATION B-1

**Note**

If the wattmeter is not available then bypass it's connection in the circuit using an N-female to N-female connector 46-265875P2.

**NON-SERVICE BODY PROTOCOL**

PATIENT REGISTER .

PATIENT INFORMATION

Patient Id **geservice**  
 Patient Name **body pmc**  
 Weight (Lb) **300 ~ IMPORTANT**  
 Landmark **[>] [Sternal Notch]**

PATIENT PROTOCOLS

PATIENT POSITION

Patient Position **[>] [Supine]**  
 Patient Entry **[>] [Head First]**  
 Coil **[...] [Body] [Accept]**

IMAGING PARAMETERS

Plane **[>] [Axial]**  
 Mode **[>] [2D]**  
 Pulse Seq **[...] [Spin Echo]**  
 Imaging Options **[Accept]**  
 Psd Name **none (default)**  
 Protocol **cal**  
 Protocol **no entry**

SCAN TIMING

\* of Echoes **1 (default)**  
 TE **[25]**  
 TR **[200]**

SCANNING RANGE

FOV **[24]**  
 Slice Thickness **[10]**  
 Spacing **0**  
 Start **0**  
 End **0**  
 # Slices **1 (default)**  
 L/R Center **0 (default)**  
 P/A Center **0 (default)**  
 Table Delta **0.00 (default)**

ACQUISITION TIMING

Freq **[256]**  
 Phase **[128]**  
 NEX **[2]**  
 Freq Dir **[>] [R/L]**  
 Auto Center Freq **[>] [Peak]**  
 (lowest window) **[Save Series]**  
**[Research Operations] [Setup Params]**  
 Set TG **50 [Done]**  
**[Research Operations] [Download]**  
**[Prepare to Scan]**

If performing Amplifier Shutdown Verification of Section 7 then be sure to enter the CVs per Table 7-1, items F - H.

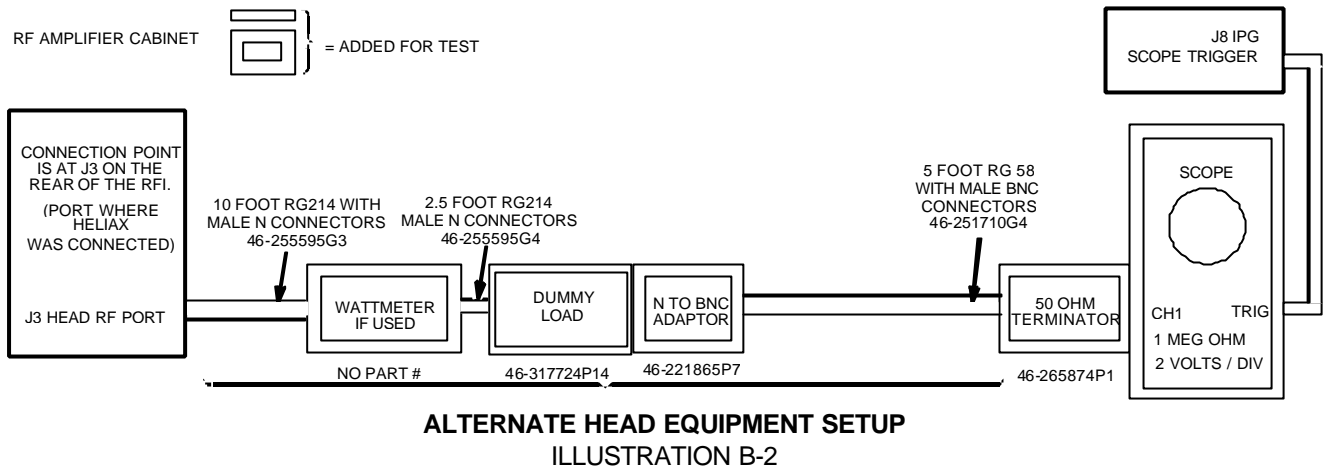

**Note**

If the wattmeter is not available then bypass it's connection in the circuit using an N-female to N-female connector 46-265875P2.

**NON- SERVICE HEAD PROTOCOL**

PATIENT REGISTER .  
PATIENT INFORMATION

Patient Id **geservice**  
 Patient Name **head pmc**  
 Weight (Lb) **300 ~ IMPORTANT**  
 Landmark **[>] [Sternal Notch]**

PATIENT PROTOCOLS **[Patient Position]**

PATIENT POSITION

Patient Position **[>] [Supine]**  
 Patient Entry **[>] [Head First]**  
 Coil **[...] [Head] [Accept]**

IMAGING PARAMETERS

Plane **[>] [Axial]**  
 Mode **[>] [2D]**  
 Pulse Seq **[...] [Spin Echo] [Accept]**  
 Imaging Options none (default)  
 Psd Name **cal**  
 Protocol no entry

SCAN TIMING

\* of Echoes 1 (default)  
 TE **[25]**  
 TR **[200]**

SCANNING RANGE

FOV **[24]**  
 Slice Thickness **[10]**  
 Spacing **0**  
 Start **0**  
 End **0**  
 # Slices 1 (default)  
 L/R Center 0 (default)  
 P/A Center 0 (default)  
 Table Delta 0.00 (default)

ACQUISITION TIMING

Freq **[256]**  
 Phase **[128]**  
 NEX **[2]**  
 Freq Dir **[>] [R/L]**  
 Auto Center Freq **[>] [Peak]**  
 (lowest window) **[Save Series]**  
**[Research Operations] [Setup Params]**  
 Set TG **50 [Done]**  
**[Research Operations] [Download]**  
**[Prepare to Scan]**

## APPENDIX C — MISCELLANIOUS RF CONVERSIONS AND FORMULAS

### RF Conversion Formulas

These are provided to assist the experienced FE with troubleshooting but are not referenced in the calibration process. The RF conversions below are presented in two different formats. The first format is the actual mathematical formula. The second format assumes that you are entering the data into the LX system calculator exactly as you read it (Access the LX system calculator by right mouse clicking in the background and then selecting the calculator from the Root menu.). Be aware that there is also an RF Power Calculator available on the LX system under the **Toolbelt icon, [Utilities], [RF Calculator], [Start]**. Watts to dBm, dBm to Watts, relative volts to relative power, and relative power to relative volts conversions can be done with the RF Power Calculator tool.

#### VP-P to dBm Calculation:

$$\text{dBm} = 20 \log \left( \frac{V_{pp}}{0.632} \right)$$

VP-P [,] 0.632 [=] [LOG] [\*] 20 [=] dBm.

#### dBm to VP-P Calculation:

$$V_{pp} = 10 \left( \frac{\text{dBm}}{20} \right) \times 0.632 \quad \text{or} \quad V_{pp} = \text{antilog} \left( \frac{\text{dBm}}{20} \right) \times 0.632$$

dBm [,] 20 [=] [INV LOG] [\*] 0.632 [=] VP-P.

**Example:** Using 3.65 dBm, the Scope Power reading listed on a particular Kit card, and the LX system calculator to determine the equivalent Vpp:

3.65 [,] 20 [=] (0.1825) [INV LOG] (1.5222991) [\*] 0.632 [=] (0.9620931) VP-P.

#### dBm to Watts Calculation:

$$\text{Watts} = 10 \left( \frac{\text{dBm}}{10} \right) \times 0.001 \quad \text{or} \quad \text{Watts} = \text{antilog} \left( \frac{\text{dBm}}{10} \right) \times 0.001$$

dBm [,] 10 [=] [INV LOG] [=] [\*] 0.001 [=] Total Watts.

## APPENDIX D — DUMMY LOAD AND CABLES CALIBRATION

**Description** - This procedure provides directions for determining the true loss attributable to the dummy load and cables used when measuring the RF output power with a wattmeter or oscilloscope of 100 MHz bandwidth or greater. It is necessary to know and account for the actual loss these components contribute in order to accurately measure RF power. This procedure is not needed if using the RF Power Measurement Kit. The RF Power Measurement Kit has already been calibrated so that this loss is known and accounted for.

### E-1 Overview

Test cables long enough to reach the cables, connectors and dummy load to be tested are connected between the Exciter RF Output (System Cabinet J1) and Receiver Body Input (System Cabinet J2). Receiver gains (R1 & R2) and transmit gain (TG) are set for near full scale reading on the power spectrum during prescan calibration. A reference scan is taken and stored in a raw file. The Attenuation Test Tool is used to calculate the baseline factor from the reference scan for the test cables (i.e., there is some loss from the test cables).

The dummy load and cable(s) to be tested are next inserted in series with the test cables and another scan is taken. Again, the Attenuation Test Tool is used to determine the "Magnitude Squared Attenuation Factor" (i.e., how much has the test signal been attenuated?). This attenuation factor is used in the RF power calibration process to accurately calculate the RF power level.

#### Note

If any problems are encountered during the following procedure, always start over at the beginning and re-do the reference scan. Then you may add, as directed in this procedure, any type of attenuation hardware you might have reason to test.

**D-2 Tools and Instruments Required**

See Table D2-1

TABLE D2-1  
REQUIRED TOOLS AND INSTRUMENTS

Item	Description	Part Number	Qty.
1	50-ohm dummy load, 200 watt, 30 dB attenuator - Bird Model 8322 (or equivalent).	46-317724P14	1
2	RF Test Cables Kit	46-255816G1	1

**D-3 Initial Setup**

1. Open the System Cabinet back door and locate the TNS module inside the upper left of the cabinet. This unit has an LCD display, Reset Button, and Disable/Enable toggle switch on the front.
2. Locate the body TNS on the TNS module. This is one of the two shiny metal TNS boxes affixed to the main TNS module assembly that is mounted farthest from the rear of the cabinet. Multicoil systems have an additional piggyback board affixed with 3 extra TNS boxes that mounts over the top of the main TNS module assembly.
3. Bypass the body TNS (A24 A1 A1) from the circuit by disconnecting the small coax cables A24 A1 A1 J12 (signal output) and A24 A1 A1 J2 (signal input) from the TNS and connecting both together using a female-BNC to female-BNC adapter (also known as a bullet adapter 46-220427P3).

**Note**

Failure to bypass the body TNS out of the circuit may result no signal being received by the system. Merely disabling the TNS by moving the Enable/Disable toggle switch down to the Disable position instead of bypassing it out of the circuit may work, however, the TNS processor can override the switch.

4. Reconfigure test hardware as shown in Illustration D3-1.

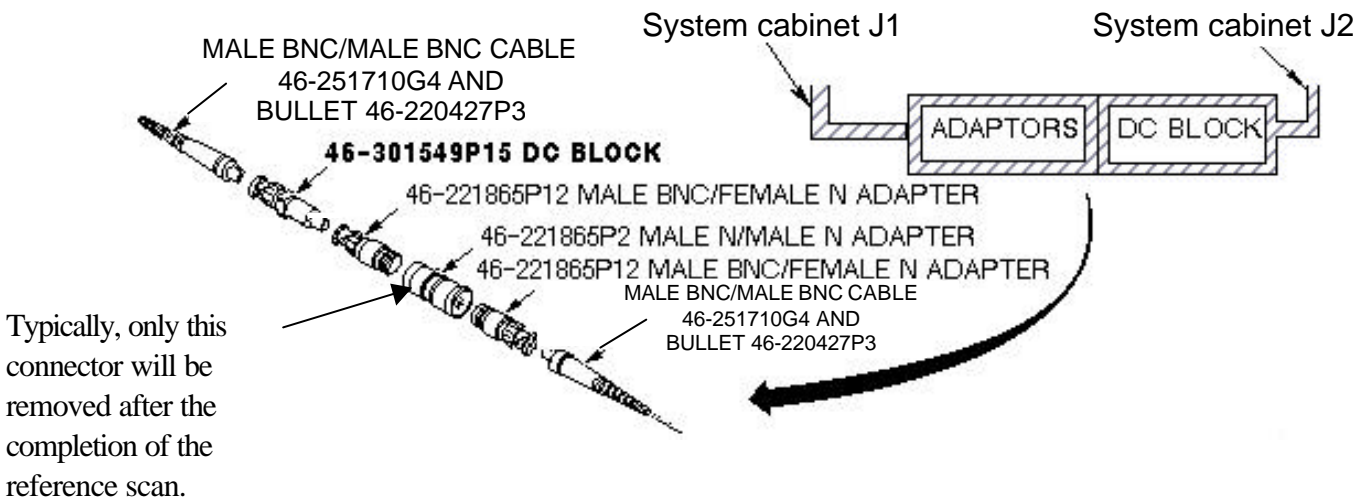
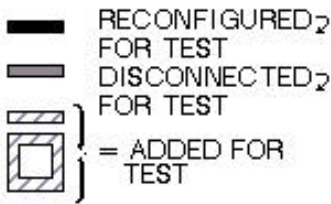

**CONNECTIONS FOR INITIAL AMPLITUDE SCAN**  
ILLUSTRATION D3-1

**Note**

Adapters not shown in Illustration D3-1 can be added, if necessary, from the RF Cables Kit. Usage of the inline DC Block as shown in Illustration D3-1 is mandatory.

5. Disconnect the existing cables at the Systems cabinet I/F panel J1 (RF Out) and J2 (Receiver Body Input) and set them aside.
6. Connect the assembled test cables and adapters between J1 (RF Out) and J2 (Receiver Body Input) on the System Cabinet interface.

7. At the operator work space, prepare the system for a Dummy Load scan using the procedure, see below.
  - a. Click on **[New Pt]**  
Id: **geservice**  
Name: **dummy load**  
Weight (Lb): **111**  
Set Patient Protocols to **Service**.
  - b. In the Protocol field, type **o.18.1** (o=Other, 1=series number) to load the protocol.
  - c. Set a landmark if necessary, then **Save Series**.
  - d. With the right mouse key, select **[Research Operations]**, then select **[Display CVs]**.  
Set value of CV **calmode** to **2** (trapezoid pulse).  
(Caution here. Make sure the previous CV has been cleared before entering the next one.  
Look at the screen!)  
Set value of CV **p2\_ramp** to **1** (1  $\mu$ sec ramp time).  
Set value of CV **t2** to **50000** (50 msec tr).  
Set value of CV **pismode** to **1** (exc service).  
Set value of CV **pmode** to **1** (data collection).  
Set value of CV **daqm** to **1** (data in window).
  - e. Select **[Accept]** and then select **[Research Operations]**, then select **[Download]** then select **[Manual Prescan]**.

**D-4 Data Collection**

1. When in **[Manual Prescan]**, set **R1** to **7**, and **R2** to **14**.
2. Adjust transmit gain (**TG**) to achieve an R1 or R2 (on IP display) of approximately 98%, without going over.
3. Select **[Done]**.
4. Select **[Scan]** (Ignore the message: MR signal too large, reduce receiver gain.) (Note: on the LX systems tested, the scan time starts at 13 seconds, counts down to 7 seconds, then ends. This is normal and is not cause for alarm.)
5. From the MR Tools desktop, select **[Cals/checks]** and then **[Attenuation Test]**.
6. Use **[Atten Test]** tool selection to analyze data, as shown in Table D4-1.

TABLE D4-1  
 DATA COLLECTION

Output/Prompts	Input/Comments
Last run number used was: XXXX	
Please enter runfile number (XXXX): .....	<Enter>
Please select Locked / Unlocked file (L,U) (U):.....	<Enter> (working)
<pre>   *****     *****   Average Max. magnitude Across All Views = aaaaa Average Max. magnitude Squared          = bbbbb Average RMS Across All Views             = ccccc ***** Do you want to make this run the reference(Y,N)(N):.....                     </pre>	
<p><b>STOP!</b> Do not answer the next question at this point.                      Continue with step 7 below.</p>	

7. The next step will involve removing only the center male N to male N adapter from the test cables, setting it aside, and adding in the dummy load and cables that need to be characterized.

**Note**

This assumes that the item to be characterized has N female connectors at it's input and output. If it has an N connector at the input and a BNC at the output or BNC connectors at both the input and output then an additional adapter(s) will be needed in order to connect it to the test cables. Adding in one or two uncharacterized adapters should not appreciably change the baseline attenuation factor. In this case, if the wattmeter is not being used, the 2.5 ft. cable (RG214, 46-255595G4) can be eliminated from the circuit. It is not needed.

8. Connect your test cables to the opposite ends of either:

- Illustration D4-1 - Dummy Load and Cables
- Illustration D4-2 - Amplifier to Wattmeter Cable.

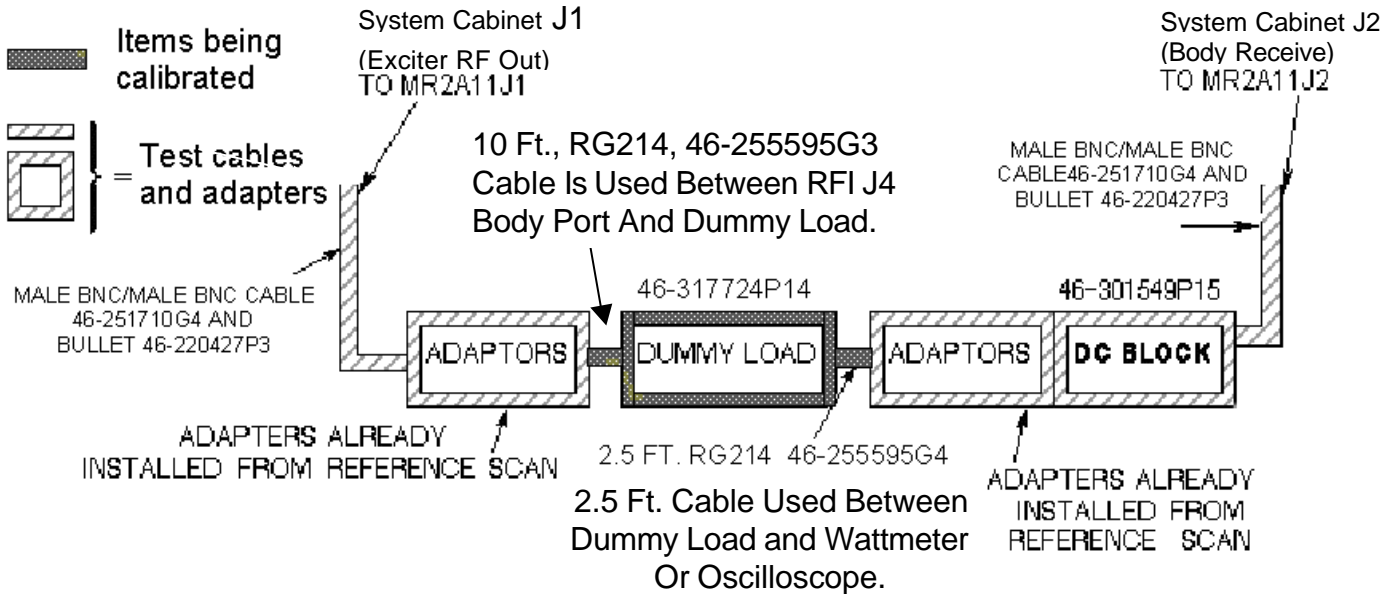

**CONNECTIONS FOR DUMMY LOAD + CABLES SCAN**  
ILLUSTRATION D4-1

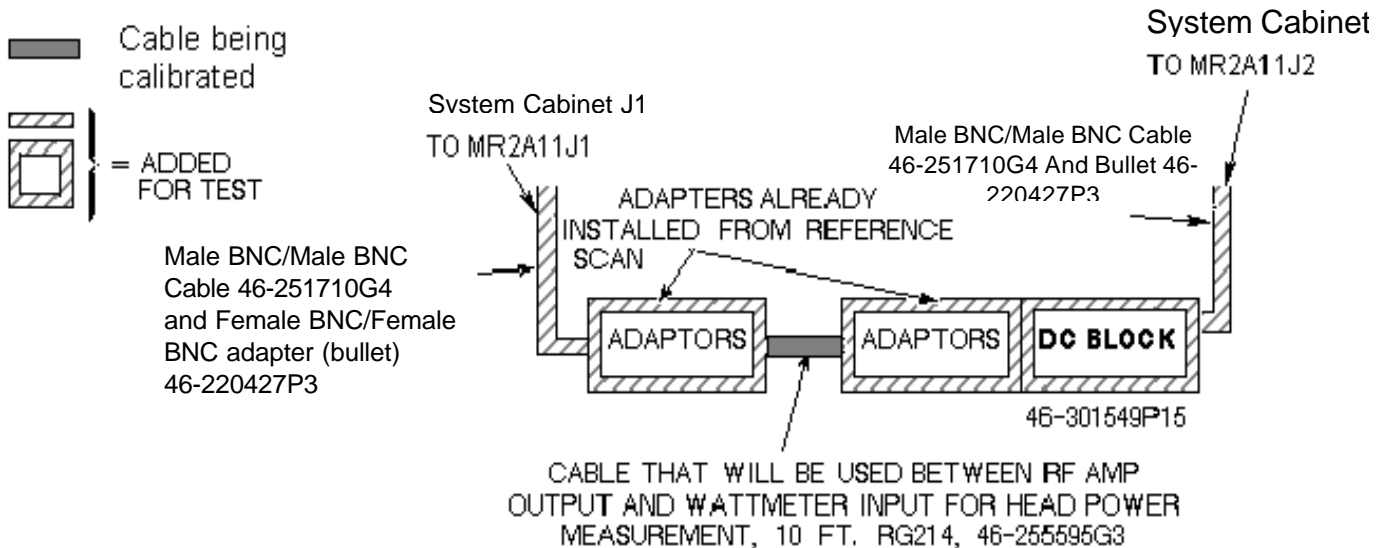

**AMP TO WATTMETER CABLE SCAN**  
ILLUSTRATION D4-2

**Note**

"Bullet" RF connector referred to in illustrations D4-1 and D4-2 is a female BNC/female BNC adapter, 46-220427P3.

9. Select the scanning icon again to activate the scanning screen.
10. Select [**Scan**].
11. When the scan is completed, re-select the tools icon again and begin the Analysis in section D-5. It will be necessary to toggle between the Scan and Toolbelt icons if multiple passes are done.

**D-5 Analysis**

See Table D5-1.

TABLE D5-1  
**ANALYSIS**

Output/Prompts	Input/Comments
Do you want to compute Gain or Attenuation Ratio(G,A)[G]:	<b>A</b> <Enter> <u>IMPORTANT:</u> Answer <b>after</b> the scan is done.
Last run number used was: XXXX Please enter runfile number [XXXX]:.....	<Enter>
Please select Locked / Unlocked file (L,U) [U]:.....	<Enter> (Working)
*****  *****	
Average Max. Magnitude Across All Views = aaaaa	
Average Max. Magnitude Squared = bbbbb	
Average RMS Across All Views = ccccc	
Magnitude Attenuation Factor = xxxxx	
Magnitude Squared Attenuation Factor = yyyyy	<====Record in "Value" column in Table D5-2.
RMS Attenuation Factor = zzzzz	
*****	

1. Record the "Magnitude Squared Attenuation Factor" number and record it in the appropriate Value box in Table D5-2.

TABLE D5-2  
**ATTENUATION FACTORS**

MODE	CALIBRATED HARDWARE	PART NUMBER(S)	VALUE	NOMINAL VALUES
BODY OR HEAD	DUMMY LOAD + CABLES ATTEN FACTOR	46-255595G3 46-317724P14 46-255595G4		1000 TO 1200
HEAD ONLY	AMP TO WATTMETER ATTEN FACTOR	46-255595G3		1.0 TO 1.2

**D-6 Calculation of RF power**

Peak voltage should be used in the calculation in order to get an accurate result. It can be converted to power using the following formula as long as certain factors are known and accounted for. The scope correction factor **MUST** be known. So must the *actual* total loss attributed to anything that connects the measuring device to the source. This often includes the accumulated loss associated with the dummy load and any interconnecting cables. Table D6-1 shows the calculation of power if all the attenuating devices in the measurement circuit exhibited perfect loss; that is, the devices added no more or less loss than what they were designed to provide. Table D6-2 shows the same calculation of power but accounts for the measurement-circuit loss values in deriving the true power. Note that the loss has a significant impact on the calculated power.



**THE SCOPE CORRECTION FACTOR MUST BE KNOWN FOR THE FORMULAS SHOWN IN TABLES D6-1 AND D6-2. IF IT IS NOT KNOWN, DO NOT USE THIS METHOD. GROSSLY INACCURATE MEASUREMENTS AND POSSIBLE SYSTEM DAMAGE WILL RESULT.**

$$\left( \frac{V_{\text{peak}}}{\text{scope correction factor}} \right)^2 \times \text{dummy load and cables attenuation} = \text{RF Power}$$

2 X Z

where "X" and "X" in the above formula signifies multiplication

Assume Z = 50 Ω , V<sub>peak</sub> = 27.53, scope correction factor = 1.00 (scope loss is negligible at 1.0T frequency), dummy load and cables atten. = 1000 (dummy load and cables are all ideal)

$$\frac{\left( \frac{27.53V_p}{1.00} \right)^2}{100} \times 1000 = 7580 \text{ Watts} = 7.58 \text{ kW}$$

This result assumes a ***theoretically perfect*** situation in which there is no loss. These situations, in common practice, rarely exist!

TABLE D6-1  
**RF POWER CALCULATION WITH NO LOSS**

Now, consider the "real life" type situation in Table D6-2 in which the loss is considered:

$$\left( \frac{V_{\text{peak}}}{\text{scope correction factor}} \right)^2 \times \text{dummy load and cables attenuation} = \text{RF Power}$$

where "X" and "X" in the above formula signifies multiplication

Assume  $Z = 50 \Omega$ ,  $V_{\text{peak}} = 27.1$ , scope correction factor = 1.00 (scope loss is negligible at 1.0T frequency),  
dummy load and cables atten. = 1028

$$\left( \frac{27.1V_p}{1.00} \right)^2 \times 1028 = 7550 \text{ Watts (very close to 7.58kW.)}$$

Accounting for the loss resulted in an accurate answer. 7550 Watts is as close as we can hope to get to 7580 Watts without using the RF Power Measurement Kit. Note that if none of the loss had been accounted for the error could have been **206 Watts or 2.7%**. As a result, the observer would attempt to adjust the RF power above the 7580 Watt limit.

TABLE D6-2  
RF POWER CALCULATION WITH LOSS CONSIDERED

**D-7 System Restoration**

1. Reconnect original cables to the System Cabinet I/F J1 and J2.
2. Remove the female-BNC to female-BNC (bullet) adapter joining A24 A1 A1 J12 and A24 A1 A1 J2 and reconnect these to the body TNS. J2 (signal input) will connect to the top of the TNS and J12 (signal output) will connect to the bottom.
3. Perform one satisfactory head or body scan.

## D-8 Wattmeter Trivia

Why are measurements between a oscilloscope and a Bird Wattmeter found to be different? Repeated GEMS Education Center lab groups that performed the Dummy Load and Cables attenuation process correctly, and obtained an accurate attenuation value, were able to accurately measure RF power as well as with a 400 MHZ scope! Remember, for wattmeter measurements however, the meter reading must be multiplied by the atten factor. Leaving this little factor out is the reason why the above 'note' was made. In body mode the wattmeter is placed after the dummy load. Its atten value must be used to calculate the correct RF value. If it is NOT used, then it should be expected there will be an error of 10% or more!

In head mode, the wattmeter is placed before the dummy load. In this case only the 'cable' factor is used to correct the wattmeter reading. The 'cable' factor is the other atten test you did for the 10 foot cable only. Typically that value is between 1.0 to 1.2. Doesn't sound like much???? Take your calculator out for a moment. Take 2,000 watts (displayed reading) and multiply by an atten factor of 1.0 ; the results are obvious, 2,000 watts. Now take the same displayed 2,000 and multiply it by an atten factor of 1.2 = 2,400 watts! Hopefully this example will show the importance of the attenuation values. You just calculated a 20% error if you were wrong because you didn't do atten test on the 10 foot cable!

## D-9 Scope Trivia

A basic 'rule of thumb' in the scope industry is that 'to accurately measure a high frequency signal, the bandwidth of the scope should be at least 5X the frequency being measured'. That means that for a 64 MHZ signal the scope bandwidth would have to be at least 320 MHZ. Along the same line, a 42 MHZ signal would require a bandwidth of at least 210 MHZ. This is why the 400 MHZ scope was chosen several years ago for MR use. Knowing this should alert you as to what might have to be done in order to get correct scope readings from whatever scope you carry today. Who knows what bandwidth scope you'll be working with tomorrow? Will it be of sufficient bandwidth to give accurate measurements? What can you do if it is not covered by the rule of thumb? Read on!

Experimentation with multiple scopes have shown that an error is typically somewhere between 0 and 16%. That's right, some 100 MHZ scopes have no loss! Others may have as much as 15 or 16%. Additionally, it has been found that it is not necessarily the whole scope that has this loss, but the individual channels typically exhibit differences. In other words, channel one might have a 3% loss when channel two could lose 15%. There is no fixed number for all 100 MHZ scopes!

How do you get around these losses? Well, there are two ways. First you could compare a RF waveform on your scope, side by side, with a 400 MHZ scope. Use the same cables etc. and just move the cables from scope to scope. You can then calculate the loss for each channel of the 100 MHZ scope vs. the 400 MHZ scope. Keep the scope intensity low for best accuracy. If and when possible, determine the losses for a 1.5T and 1.0T system. That's for 64 and 42 MHZ. Point of note: there are various losses at 42 MHZ as well as with 64 MHZ. And, typically they differ! Your scope may have a 0 to 15% rolloff at 64 MHZ and 0 to 12% at 42 MHZ. All scopes differ!

Secondly, the next time you have your scope calibrated, just attach a tag asking for the % loss of signal at 42 and 64 MHZ for each channel. You should also state that you want this to be done at the 5 and 2 volts/div setting. This will cover both body and head measurements. At two different re-calibration vendors we use, there are no extra charges incurred for this request.

As mentioned above, the 100 MHZ scope has been shown to be as accurate as a 400 MHZ scopes if the scope rolloff factor is known. Additionally, each channel has it's own unique loss factor.

The biggest error found in GEMS Education Center labs when measuring RF power has proven to be the FE using "typical" dummy load and cables attenuation factors. Basically there are no "typical" factors! All loads and cables are somewhat different. Several may appear to be close in value, but in most cases they are different. If you use a "typical" atten factor in your calculations, then "typically" you will be in error.

Through experimentation at the GEMS Education Center, it has been determined that if you know the attenuation factor for a particular dummy load and cables, those values hold over several years. They do NOT tend to change. This means that if you could do atten test on a dummy load and cables, and keep them as a kit, you don't have to recalibrate them every time you use them. Wow! And possibly a little cheaper than the Power Measurement kit.

If you must, or intend to use a scope to measure body RF power, use atten test on the dummy load and cables.

Knowing the correct attenuation values and the correct scope rolloff values will provide you with measurements as accurate as a 400 MHz scope and / or the GE Power Measurements kit.

**REVISION HISTORY**

<b>REV</b>	<b>DATE</b>	<b>AUTHOR</b>	<b>PRIMARY REASONS FOR CHANGE</b>
1	May 19, 1999	Resa Lambert	Updated initial 1.0T procedure. Corrections made as well including new Illustrations for equipment setup.  Released on 2160623-1 Rev7 CD-ROM.
2	Sept 2, 1999	Resa Lambert	Updated initial 1.0T procedure to include 1.0T and 1.5T versions, therefore, combining 2 documents into one new document beginning at Rev 0. Corrections made as well including new Illustrations for equipment setup. Added Appendix B, C and D. Added SCOPECAL.xls Tool. Added measurement example/tutorial. Moved Head checks first in the process.  Released on 2160623-1 Rev8 CD-ROM.
3	Dec 2, 1999	Resa Lambert	Updated P.M. Tables for SSM vs. RFSC.
4	July 28, 2000	Don Thome'	Created 1.0T, class A specific document. Re-wrote RF measurement section and added directions for using RF Calculator Tool. Added process flowchart in Overview. Added Alternate Non-proprietary protocols (Appendix B), Dummy Load and Cable Calibration document (Appendix D).