

TABLE OF CONTENTS

| | |
|---|-----------|
| TABLE OF CONTENTS | 1 |
| 1- INTRODUCTION | 2 |
| 1-1 Overview | 2 |
| 1-2 Camera Vendor Participation | 2 |
| 2- VERIFY AMBIENT LIGHTING CONDITIONS | 2 |
| 3 – EIZO MONITOR INSTALLATION | 2 |
| 4- LCD AUTO ADJUSTMENT AND SCREEN MANAGER OPERATIONS | 4 |
| 5- SIGNA HOST GAMMA SETUP- EIZO L660 | 5 |
| 5-1 Installing the Gamma Look-Up-Table for the Eizo L660 LCD Color Monitor | 5 |
| 6- SETTING LCD MONITOR FREQUENCY RATE | 7 |
| 7- LCD CALIBRATION FOR OPTIMUM IMAGE VIEWING | 9 |
| 7-1 Displaying the SMPTE Pattern | 9 |
| 7-2 Adjusting for proper Window and Level Setting | 12 |
| 7-3 Fine Tuning the Contrast and Brightness using the SMPTE Pattern | 12 |
| 7-4 Locking the Screen Manager Settings | 13 |
| 7-5 Unlocking the Screen Manager Settings | 13 |
| 8 - CAMERA CALIBRATION | 15 |
| 8-1 DASM Interpolation Setup | 15 |
| 8-2 Camera Imaging Look-up Table..... | 15 |
| 8-3 Camera Maximum Optical Density..... | 15 |
| 8-4 Camera Contrast..... | 15 |
| 8-5 Anatomical Filming | 16 |
| 9 - TROUBLESHOOTING GUIDE | 17 |
| A- APPENDIX A | 19 |
| A-1 Focus, Screen position, Clock Rate and Phase Adjustments..... | 19 |
| A-2 Manual Adjustments of Controls..... | 21 |
| A-3 Adjusting Focus Using LX Calibration Tools From Toolchest (Alternate)..... | 23 |
| A-4 Setting up LCD Display for Contrast/Brightness. Using LX Calibration Tools From Toolchest (Alternate) ... | 24 |
| REVISION HISTORY | 25 |

1- INTRODUCTION

1-1 Overview

The operator workspace monitor must be properly adjusted for the filmed image to accurately represent the console monitor displayed image. This procedure will describe how to adjust the LCD display monitor to match the camera. Once the LCD display monitor is re-calibrated, it is essential to re-calibrate the camera before the system is used for filming.

1-2 Camera Vendor Participation

It is recommended that this procedure is performed with the Camera Vendor field engineer, present, should any camera adjustment be necessary. To optimize customer satisfaction, it is also recommended that you have one of the Customer's filming specialists available for the fine tuning and quality review of the film/LCD display monitor conformance.

2- VERIFY AMBIENT LIGHTING CONDITIONS

In the review area and operator workspace area, verify that the ambient lighting conditions are adjusted to a minimum level. In the operator workspace area, there should be only sufficient light for safely operating the system.

In the review area and operator workspace area, verify that light-boxes are not emitting light, or are properly masked, when not displaying film. This will be a source of excessive glare

In both review area and operator workspace area, verify that there is no source of glare for reviewing films or setting up the images for film. For example, windows should not allow direct light. (blinds should be closed).

Note that both, the operator workspace area and the review area artificial lighting type should be of the same type.

3 – EIZO MONITOR INSTALLATION

1. Shutdown Signa and perform a safety lockout/tagout of the Operator Workspace.
2. Remove the new LCD monitor from its box and its packing and set the Eizo L660 LCD color monitor on the workspace desktop and remove its rear cover. See Illustration 3-1

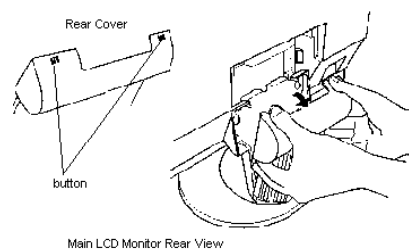

REMOVING BASE COVER
ILLUSTRATION 3-1

1. Connect the Video and power cables. Route these cables through the base. See Illustration 3-2.

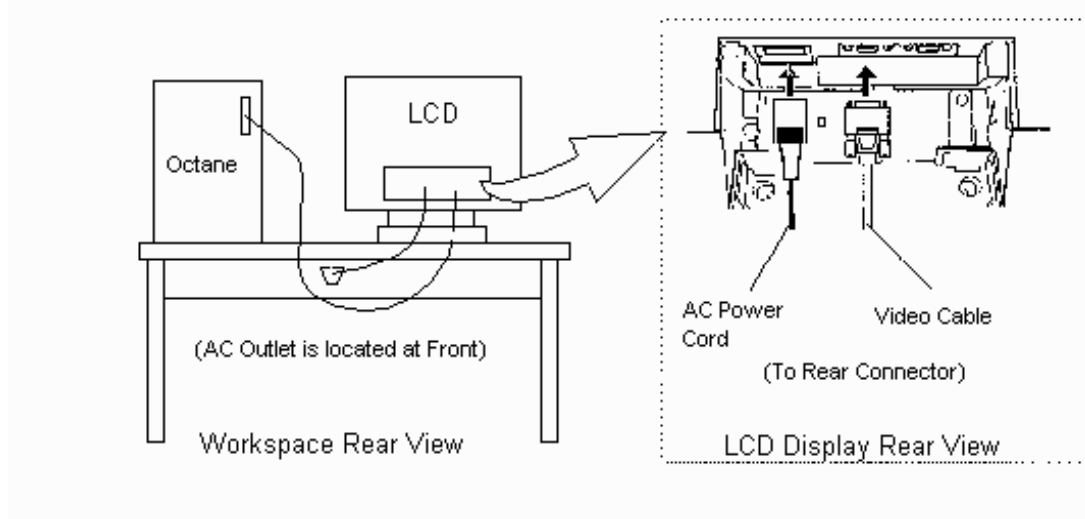

VIDEO AND POWER CABLE CONNECTIONS
ILLUSTRATION 3-2

2. Re-attach the cover to the back of the LCD. See Illustration 3-3

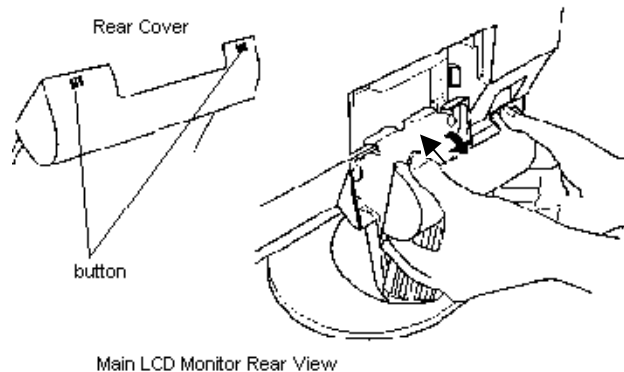

REPLACING THE BASE COVER
ILLUSTRATION 3-3

3. Remove the Safety Lockout of the Operators Workspace and restore power to the system.
4. Verify that main LCD monitor power is ON. If not, press the power button on the front panel to turn the main LCD monitor ON. See Illustration 3-4.
5. The monitor should be positioned no closer than 16 inches and no further away then 28 inches from your eyes. The optimal distance is 24 inches for either of the monitors.

Note

Allow the monitor to warm-up for 20 minutes before performing any adjustments.

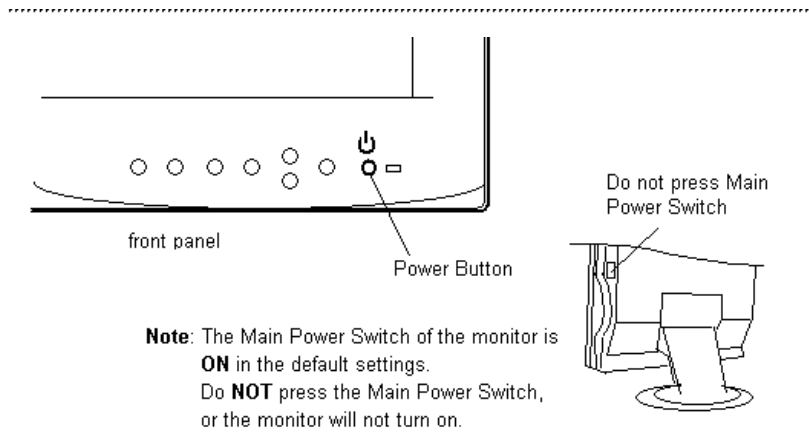

POWER BUTTON AND POWER SWITCH LOCATION
ILLUSTRATION 3-4

1. Boot up Signa
2. Password: **adw2.0**

4- LCD AUTO ADJUSTMENT AND SCREEN MANAGER OPERATIONS

This section should get you familiar with the basic operation of the monitor controls. The intent of this section is to adjust the monitor to a "default" condition to proceed with calibrations. It also will allow you to become familiar with the button panels and the Screen Manger setup.

1. With the monitor ON, press the Auto Adjust Button.

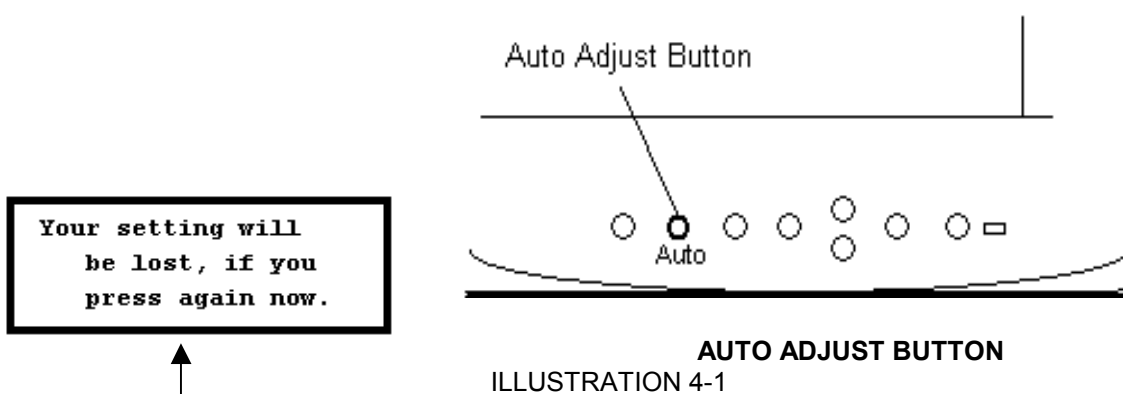

2. While the message is on the screen (within 5 seconds), press the Auto Adjust Button again to automatically center the screen.
3. Press the Contrast up button. Set to 80%.
4. Press the Brightness up button. Set to 80%.

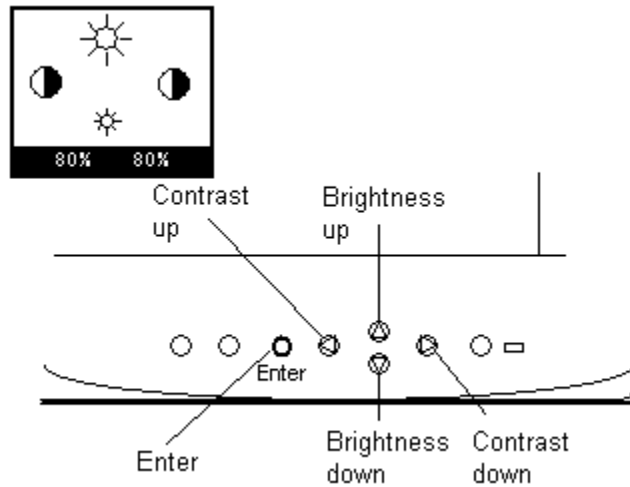

ADJUSTMENT
ILLUSTRATION 4-2

5. Press the Enter Button. All adjustments are now saved. When Auto Adjust button is pushed, the LCD will return to these settings. These settings will remain in effect even if power is removed, or system software is re-booted. Unless manually changed by the operator in the Screen Manager.
6. For further information, of the Screen Manager and button identification, refer to Appendix A. You may also review the EIZO User's Manual that came with the LCD Display.
7. The LCD Display Monitor is now ready for calibration.

5- SIGNA HOST GAMMA SETUP- EIZO L660

The GAMMA value is modified to optimize the contrast level of the image mid-tones to more closely represent the same contrast that is filmed. This process uses a "Look-up" table for closer HIPPA and DICOM compliance versus a single gamma setting on earlier models of LCD's and CRT's.

5-1 Installing the Gamma Look-Up-Table for the Eizo L660 LCD Color Monitor

1. Insert GEMS Service Documentation CD ROM 2160623 Rev 14. Or Service CD 2250758 Rev 2 into the Signa host CDROM drive. The service class of the service CDROM does not matter.
2. On the Host SGI Computer, Open **C-Shell**.
3. Type: **cd /usr/g/bin** <enter> (IRIX is case sensitive. Always use case exactly as shown)
4. Type: **su root** <enter> At password, type: **operator** <enter>
5. Type: **mediad** <Enter> (Mount CDROM Drive to File System, takes 20-30 seconds)

Note

If a message appears stating "another mediad is already running", ignore it.

6. Type: **/CDROM/gamma/setfiles** <enter>

Note

Message appears stating the action was performed.

7. Type: **umount /CDROM** <Enter> (Release the CDROM Drive.)
8. Type: **exit** <Enter> (Changes user privileges. "root level" access to "sdc level" access).
9. Type: **rungamma** <Enter>
10. The menu shown in Table 5-1 will display.

TABLE 5-1
GAMMA TOOL SELECTIONS

```
Make a selection between 1 and 7 to proceed!  
  
[1] For INSTALLING NEC 2010X Calibration  
[2] For UNINSTALLING NEC 2010X Calibration  
[3] For INSTALLING NEC 1850X Calibration  
[4] For UNINSTALLING NEC 1850X Calibration  
[5] For INSTALLING EIZO L660 Calibration  
[6] For UNINSTALLING EIZO L660 Calibration  
[7] For QUITTING this Program
```

11. Determine the LCD monitor type your system is using. The name and model number is usually found on the front face of the monitor.
12. At the prompt type the number corresponding to your monitor type and if you wish to install or uninstall the gamma tables.

The tool takes only seconds to run. A successful installation or removal message will appear and the system will go back to the command line prompt. Any errors reported will also suggest what to do next.

13. type: **exit** <enter> Close the C-Shell.
14. Remove the Service CDROM from the drive at this time.

Note

If you push the button on the front of the CDROM Reader and it does not open, it is because you did not properly "un-mount" the CDROM from the File System.

1. Re-open a C-shell
2. login as root, Password: operator
3. Type: **umount /CDROM**. (Make sure to type "umount" not "unmount")
4. Exit the C-Shell.
5. Eject the CDROM with the button.

Re-boot Signa to save and activate the change to software.

6- SETTING LCD MONITOR FREQUENCY RATE

1. Boot signa down and restart the system.
2. At the login window type **root** (Do not select the Signa boot icon or type Signa)
3. Type the password **operator** [Enter].
4. A menu like that shown in Illustration 6-1 should appear in the upper left corner of the display within 20 seconds. Make the selections as shown in Illustration 6-1 and 6-2.

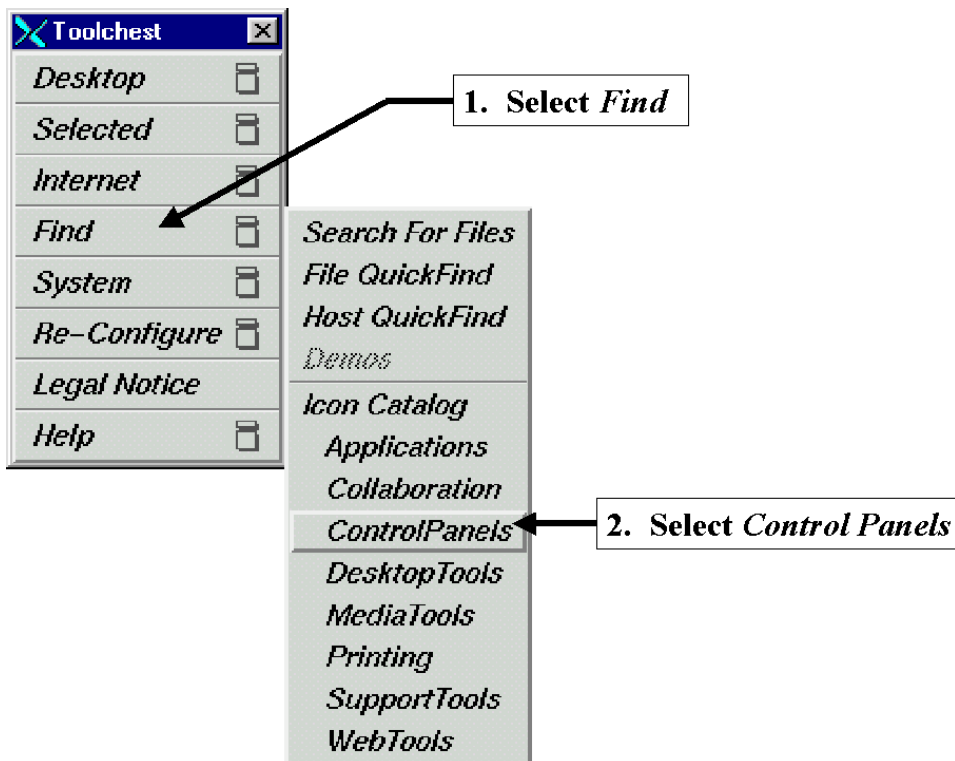

TOOLCHEST MENUS
ILLUSTRATION 6-1

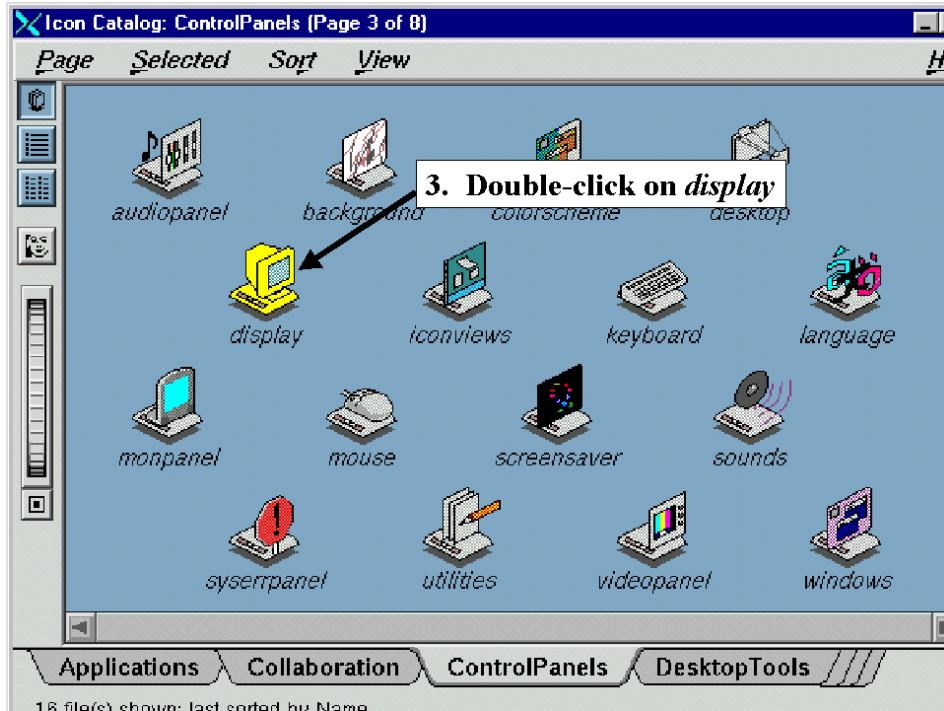

DISPLAY SETTING THROUGH CONTROL PANELS
ILLUSTRATION 6-2

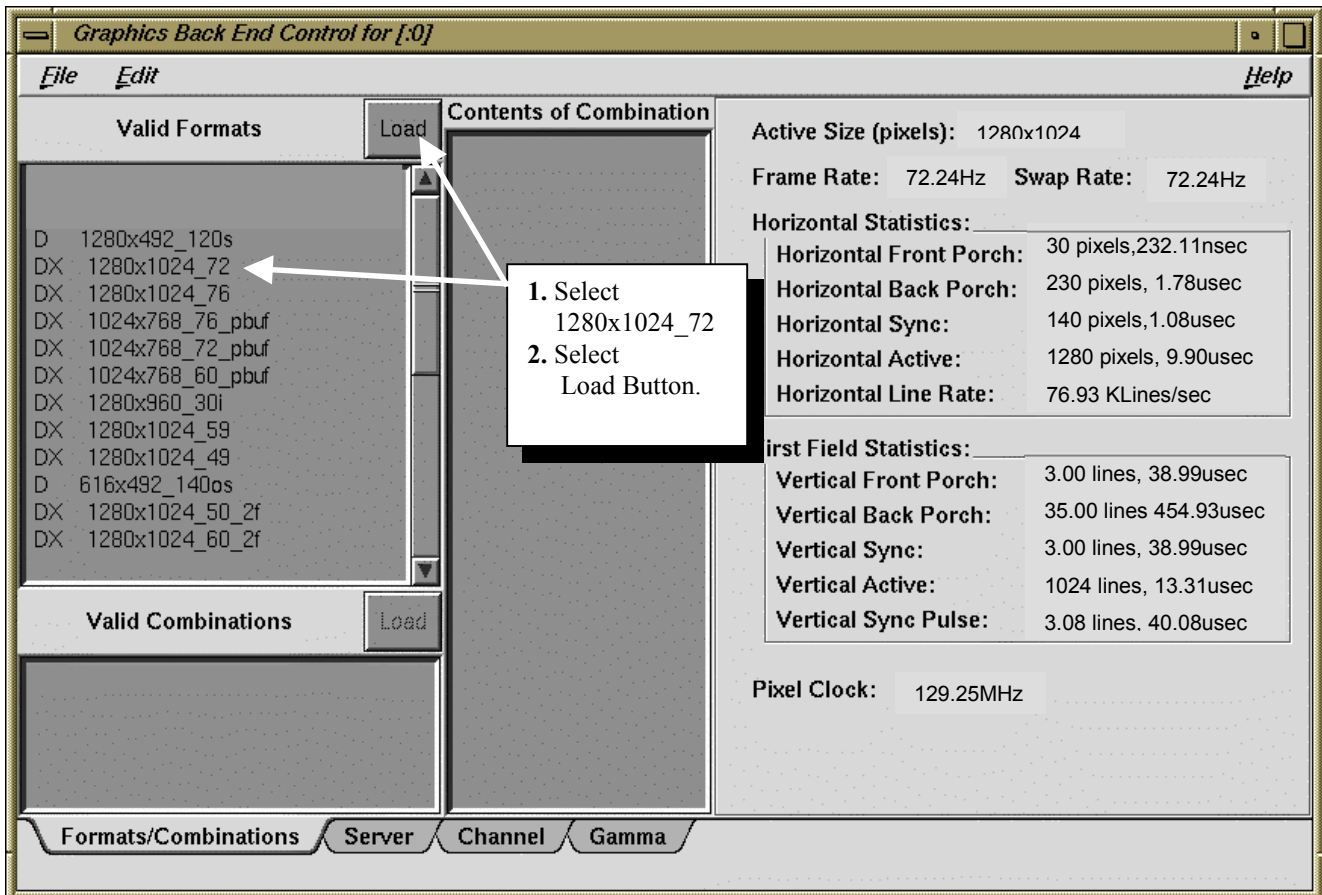

LINE RATE WINDOW
ILLUSTRATION 6-3

5. From the Display screen select **1280 X 1024_72**.
6. Verify that **1280 X 1024_72** is highlighted. At the top left of the selection window select **Load**.
7. Answer **OK** to the display message prompting you to load the new format.
8. A second display message will appear asking if you want to make the new format the power-on default. Select **OK**.
9. The screen will immediately change to the new setting.
10. From the upper left corner of the Graphics Back End Control window select "**File**" and "**Exit**".
11. Position the cursor over the Toolchest label bar at the top of the Toolchest menu, single-click with the **Right mouse** button and then select **close** from the list of selections to close the Toolchest menu.
12. **Right click** the mouse on the background of the display to open up a drop down menu.
13. Select **logout** from the menu. Answer **yes** to the display message that appears.
14. Boot Signa back up.
15. Login : **Signa** Password: **adw2.0**

7- LCD CALIBRATION FOR OPTIMUM IMAGE VIEWING

The SMPTE (Society of Motion Picture and Television Engineers) test pattern is used to provide a standard image for calibrating the Window and Level of the display for an MR scanner.

7-1 Displaying the SMPTE Pattern

The Window and Level adjustments must now be set to ensure site to site uniformity in image appearance. The SMPTE test pattern is available on the Operator Workstation Host Computer after IRIX, (The operating system) has been booted, and after you have logged into the system.

1. Install and display the SMPTE pattern. Using the steps in illustration 7-1 Below :

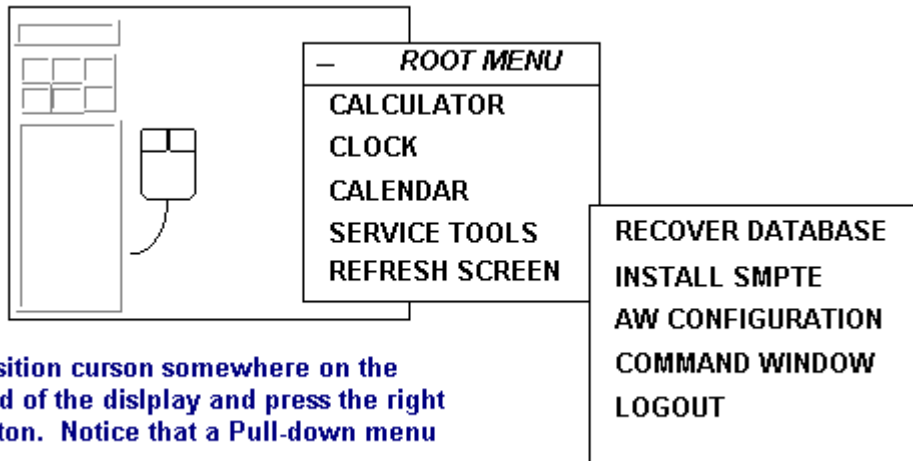

Step 1. Position cursor somewhere on the background of the display and press the right mouse button. Notice that a Pull-down menu appears.

Step 2. Slide the mouse down to [Service Tools], and then over to [Install SMPTE]. This will load the SMPTE pattern into the database as Image 1000.

INSTALLING THE SMPTE PATTERN
ILLUSTRATION 7-1

2. Displaying the SMPTE Pattern by following the steps in illustration 7-2 below.

Step 1. Point to and click on the Display icon. Notice that the Browser comes up.

Step 2. After the Browser comes up, use the scroll bar on the right side of the display to find Image 1000 SMPTE.

Step 3. Point to and single-click on the SMPTE entry.

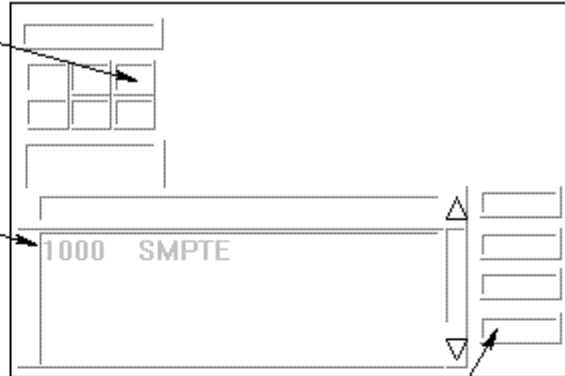

Step 4. Point to and single-click on the Full Viewer to display the SMPTE so that it is full screen size.

Step 5. To get back from displaying the SMPTE pattern, hit <ESC>.

INSTALLING THE SMPTE PATTERN
ILLUSTRATION 7-2

7-2 Adjusting for proper Window and Level Setting

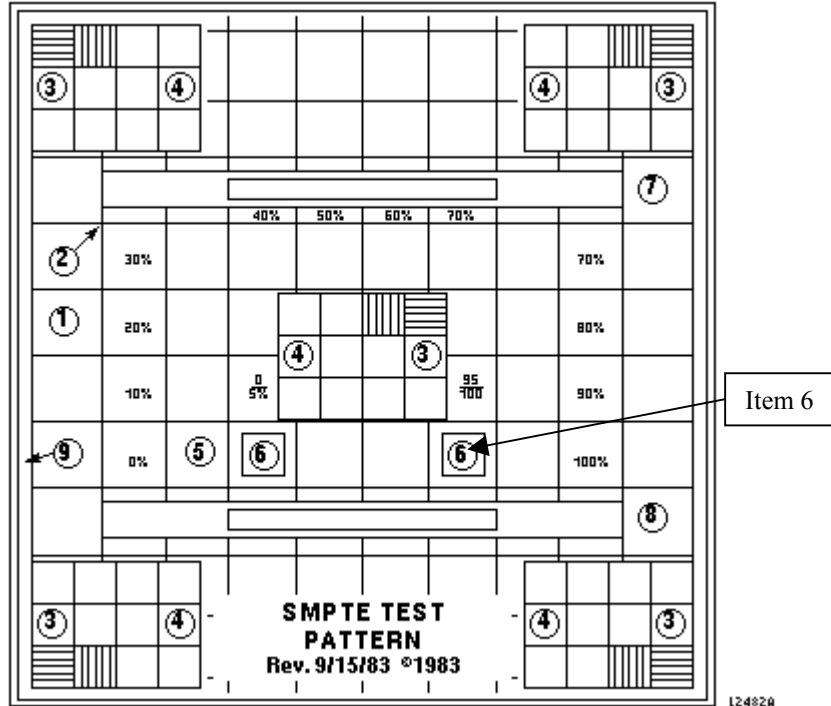

SAMPLE SMPTE TEST PATTERN
ILLUSTRATION 7-3

1. With the cursor inside the displayed image, hold down the middle mouse button and move the mouse in the horizontal plane. View the window control value at the base of the image and **set window control value to 100**.
2. With the cursor inside the displayed image, hold down the middle mouse button and move the mouse in the vertical plane. View the level control value at the base of the image and **set level control value to 1024**.

7-3 Fine Tuning the Contrast and Brightness using the SMPTE Pattern

In this section you will adjust the Contrast and brightness controls of the LCD Monitor to optimize the SMPTE Test Pattern for the Window and Level controls.

Minimal adjustment should be necessary at this time. However, it is important that you "fine tune" the Contrast and Brightness level using an industry Standard Test pattern.

This is an iterative process by adjusting the contrast, then brightness, and then back to contrast. Refer to Illustration 7-4 on the next page as you continue with this section.

Note

To reduce visible tearing or smearing of the pattern, LOWER the contrast.

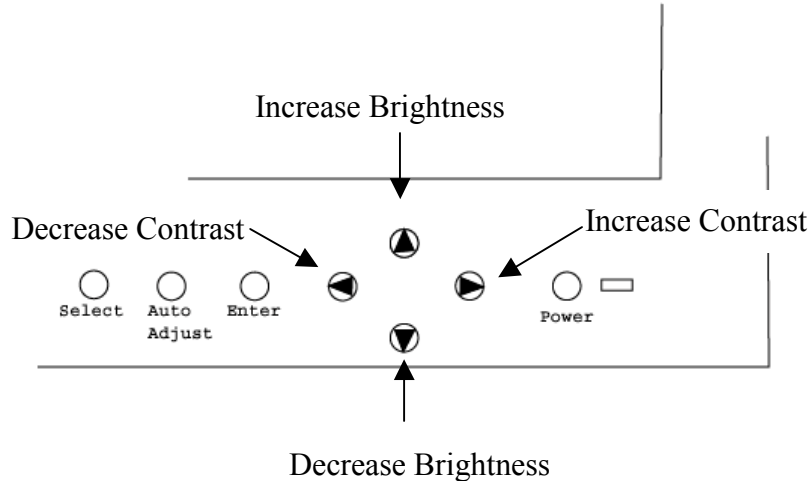

ILLUSTRATION 7-4
EIZO LCD MONITOR CONTROLS

3. Look at the Pattern. If the 5% and 95% patches are not visible.(item 6, Illustration 7-3), adjust the brightness control of the display monitor until you can just barely see them. You may also need to re-adjust the contrast, if tearing or smearing of the pattern occurs. (items 1 and 2, and 5 through 8, Illustration 7-3).Continue adjusting both brightness and contrast until the image is as crisp and clear as you can make it, and the 5% and 95% patches are just barely visible.
4. When satisfied with the display, **push the Enter Button** on the monitor to save the adjusted Contrast/Brightness settings.

7-4 Locking the Screen Manager Settings

The Eizo L660 is equipped with an adjustment-locking feature. However, it does not prevent the Operator from adjusting Contrast and Brightness settings.

To lock access to the Screen Manager:

1. Turn off the LCD Display with the front power switch.
2. Press and HOLD the Auto Adjustment button, at the same time push the Power button to turn the LCD Display ON. This will disable access to the Screen Manager.

7-5 Unlocking the Screen Manager Settings.

To unlock the Screen Manager:

1. Press and HOLD the Auto Adjustment button, at the same time push the Power button to turn the LCD Display OFF. This will enable access to the Screen Manager

Note

These settings will remain in effect even if power is removed or the system is re-booted. Because an operator can tamper with the Brightness and Contrast Adjustments, It is highly recommended that you make all operators aware of the affect they will have on system image quality.

Note

If the operator chooses to deviate from this Brightness and Contrast adjustment, ensure the camera imaging and calibration has NOT been affected.

5. Remove the SMPTE Pattern by pressing the **[ESC]** key.

8 - CAMERA CALIBRATION

This procedure describes the steps necessary to verify and set the camera parameters. Once the display is re-calibrated, it is essential to re-calibrate the camera before the system is used for filming. Although a qualified GE Service Engineer could perform the steps below, it is recommended that the following procedure be performed with the on-site assistance of the camera vendor field engineer.

8-1 DASM Interpolation Setup

1. Select the **Install** soft key from the Service Desktop. When prompted, login using the password **operator**.
2. Select the **DASM** folder from the top of the Guided Install GUI once it appears.
3. Set the DASM Interpolation method to **linear**.
4. Before exiting the GUI, insert the SaveInfo MOD or new MOD into the drive. Go to the top left corner of the Install GUI and select **<File>** and then **<Save GI Configuration to MOD>**. This process does not create a SaveInfo disk. It just creates a copy of the information already entered in the GUI tabs for use in the next software install.
5. Exit the install GUI by selecting **<File>** then **<Quit>**. If any error conditions still exist, you will be warned that no changes will be made before exiting.

8-2 Camera Imaging Look-up Table

Verify with the camera vendor field engineer that the currently installed camera lookup table is designed to provide perceivably linear contrast for the light box conditions in the customer's viewing area. If not, request that the camera vendor field engineer replace it with the appropriate look-up table.

8-3 Camera Maximum Optical Density

Note that for optimal reviewing, the light box luminance of the diagnostic region of the film should be in the range of 50 to 500 nits. Vary the maximum optical density setting of the camera to compensate for the light box and to meet this value. A good starting position is a maximum density of 2.8.

Note

The final OD settings may be refined by the radiologists performing the image review.

8-4 Camera Contrast

1. With the maximum /minimum optical densities set to compensate for the review area's light box, select a look-up table for your camera that will produce a perceivably linear gray scale for the same light box and the overall ambient light conditions of the viewing area.

Note

The DICOM 3.14 Standard specifies the Barten's curve for linear perception. It is recommended that the manufacturer base perceptual linearity on this curve.

2. Film the SMPTE pattern on a 1-on-16-format display. Verify that the 5% and the 95% levels are visually equivalent. If not, perform a Contrast test with the SMPTE pattern. Select the new contrast setting from the contrast image set. A good value for the Imation DryView is 3. Use the camera's calibration procedure to set the contrast setting. Ensure that the camera maintains a perceivably linear gray scale.

Note

Filming the SMPTE pattern for contrast calibration may be optional for the camera vendor.

3. Ask the technologist to display a clinical image and set window and level controls for the desired appearance. A good image to start with is a sagittal or axial head image.
4. Capture the image on the keypad or host control interface.
5. Print a Contrast Test film. Ask the technologist to select the image that best matches the displayed image on the monitor.
6. Observe the image number below the selected image and set the Contrast control to this value.

8-5 Anatomical Filming

This portion of the procedure requires the technologist to verify the camera settings with true anatomical images.

1. Film representative anatomical images to confirm the settings. The image set should include T1 and T2 head images, joint images and c-spines.
2. Observe the accuracy of the low-tones, mid-tones and high-tones. If a filmed image is found to not be equivalent then re-calibrate the camera based on the customer's evaluation.

9 - TROUBLESHOOTING GUIDE

The following section provides suggestions for troubleshooting the LCD monitor:

- **No Picture**
 - For Eizo monitor, push the Select button (See section 12 for help finding the select button) to insure the wrong port is not selected.
 - The signal cable should be completely connected to the display card/computer.
 - The display card should be completely seated in its slot.
 - Power Switch and computer power switch should be in the ON position.
 - Check the signal cable connector for bent or pushed-in pins.

- **Image Persistence**
 - Image persistence is when a “ghost” of an image remains on the screen even after the monitor has been turned off. Unlike CRT monitors, the LCD monitor’s image persistence is not permanent. To alleviate image persistence, turn off the monitor for as long as an image was displayed. If an image was on the monitor for one hour and a “ghost” of that image remains, the monitor should be turned off for one hour to erase the image.

Note

It is recommended that a screen saver be used whenever the screen is idle.

- **Image is unstable, unfocused, or swimming is apparent**
 - Signal cable should be completely attached to the computer.
 - Check the monitor and your display card with respect to signal timings.
 - Change the video mode to non-interlace and use a 50 Hz refresh rate.

- **LED on monitor is not lit (no green or amber color can be seen)**
 - Power Switch should be in the ON position and power cord should be connected.
 - Make certain the computer is not in a power saving mode.

- **Display image is not sized properly**
 - Push the Auto adjustment button.

- **Selected resolution is not displayed properly**
 - Push the Auto adjustment button.

- **Diagnostic Image Quality has been traced to problem with LCD setup.**
 - Operator has adjusted the Brightness and Contrast of the monitor which has affected Camera/Film imaging. Re-calibration may be necessary. Start with Section 1 of this procedure.

- **Areas of white in the image displayed appear slightly blue.**

- The Color Mode is set at Mode 2. It must be changed to Mode 1 "default" value. You will find this adjustment in the Screen Manger Menus. Refer to sections A2- A6 in Appendix-A to access and change the Mode. You can also refer to the Eizo User's Manual that came with the monitor.
- **Areas of white in the image displayed appear slightly red.**
 - The Color Mode is set at Mode 3. It must be changed to Mode 1 "default" value. You will find this adjustment in the Screen Manger Menus. Refer to sections A2- A6 in Appendix -A to access and change the Mode. You can also refer to the Eizo User's Manual that came with the monitor.

A- APPENDIX A

A-1 Focus, Screen position, Clock Rate and Phase Adjustments.

The Auto Adjust procedure done in Section 4 takes care of these for you. All other values in the Screen Manager should stay at the default values except Contrast and Display.

Use this appendix only if you see problems with Focus, screen position relative to monitor mask or phase problems (horizontal bars sweeping through the LCD). Or any vertical problems. **If there are no problems with these items, skip this section and proceed to Section 7.**

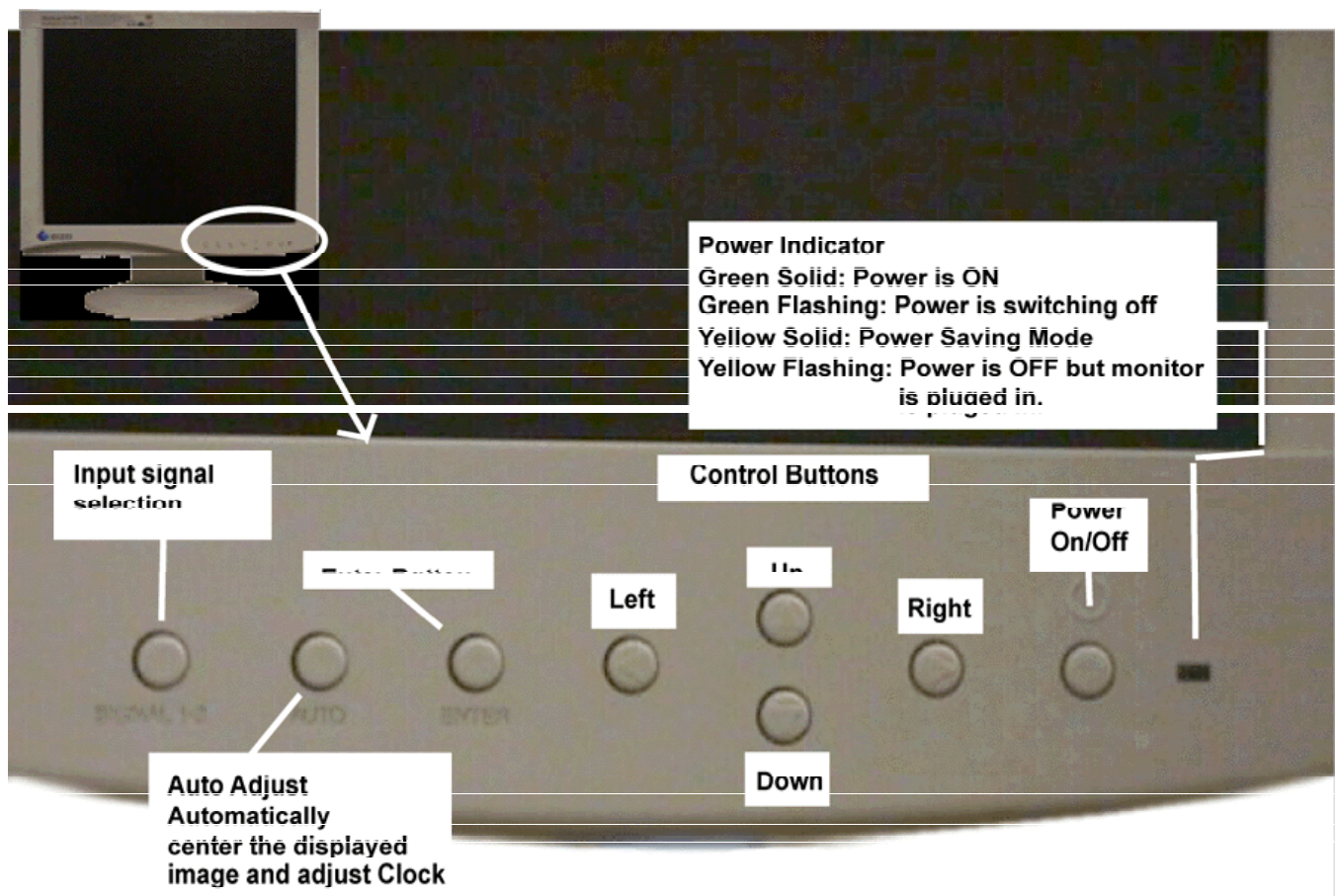

DISPLAY OPERATION
ILLUSTRATION A-1

1. Open the Screen Manager by pressing the **Enter button**.
2. Enter the desired sub-menu by selecting the Icon pressing the Arrows to the desired section.

Screen Manager consists of a main menu and six sub menus.

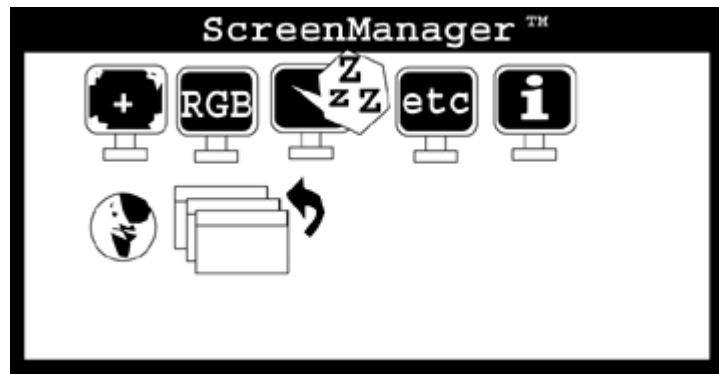



SCREEN MANAGER
LLUSTRATION A-2

Table A-1 gives a brief description of each menu item.

TABLE A-1
SCREEN MANAGER ICON DEFINITIONS

| Icon | Function | Comments |
|------|---------------|---|
| | Screen | The screen function is used to manually adjust frequency, image position, resolution, contrast and brightness. Only contract and brightness are adjusted to 80 percent for Signa applications. Other features are adjusted using the monitors auto adjust button on the front of the monitor. |
| | Color | This selections if used to make fine adjustments to the display color of the monitor. These adjustments should be left at the default for Signa applications |
| | Power Manager | Used to setup the power management features of the monitor. These adjustments should be left at the default for Signa applications. |
| | Others | Allows adjustments to screen size, border intensity, input priority, power down timer, monitor beeps and if necessary allows resetting the monitor to factory setting. These adjustments should be left at the default for Signa applications. |
| | Information | This menu shows the current ScreenManager settings. No adjustments are made here. |
| | Language | Used to set the language the monitor menu will display in. This only effects the ScreenManager menus and has no effect on display data and text being sent from the host computer. |
| | Exit | Click this Icon to exit ScreenManager. |

A-2 Manual Adjustments of Controls.

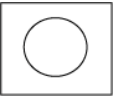
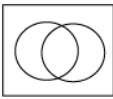
- Adjust Contrast and Brightness → 
- Image Adjust → 
- Clock Adjustment → 
- Phase Adjustment → 

1. The Screen Manager Window will disappear in 45 seconds unless you select a sub-menu using the appropriate arrow button. If necessary, push the **Enter** button on the monitor to display again.



2. Select the **Screen** menu.

3. If you observe vertical bars or non-linearity's in the pattern, select the **Clock**

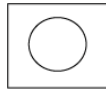

adjustment function to reduce the vertical distortion on the monitor. Use the Right and Left Arrow buttons to eliminate this problem

4. If you observe horizontal bars or non-linearity's in the pattern, select the **Phase**

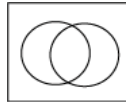

adjustment function to reduce the vertical distortion on the monitor. Use the Right and Left Arrow buttons to eliminate this problem

5. Press the Enter button to memorize both the Clock and the Phase setting.

6. If the screen position needs to be aligned, select the **Position** icon  and **push enter button**. Adjust the image position using the controls to align the screen.

7. Adjustment markers will appear. Use the arrow buttons to align the screen to the adjustment markers.

8. Press the **Enter button** to memorize both the Position setting.

9. Press the **Resolution button** and select the desired resolution. **1280 X 1024**

Note

75 represents 75Hz. This is the maximum frequency rate that this setting can use. The Display Controller of the system will be should set at 50Hz, which is the the optimum setting to maximize image display. (Refer to Section 6)

10. Press enter button to memorize the setting.

11. Select **Brightness/Contrast**  icon.

12. Push the Auto Adjustment button and the COntrast and Brightness adjustment will be automatically adjusted. The Screen blanks momentarily as it adjusts to the maximum contrast value.

13. Adjust the brightness to the desired level.

14. Push the **enter button** to save the adjusted settings.

15. Color Adjustment should be set to **MODE 1**

16. Gain Adjustment. Before setting the Gain adjustment always start by using the "**Reset**" button to set the gains to the default value.

a. set all gains at 100%.

17. Power-Saving Setup- This should stay at the default setting.

18. All other setting should remain in the default position.

19. Use the **return button** to go back to the Main Screen Manager Window.

20. To SAVE all values entered and EXIT, Select the **Exit Icon** or press the enter button twice.

Note

Adjustment information is not lost when the power is removed from the monitor. Front Panel Controls.

The functions of the controls on the front of the monitor are shown in Illustration A-1

A-3 Adjusting Focus Using LX Calibration Tools From Toolchest (Alternate)

This section is normally not needed. However, if you cannot adjust the monitor satisfactorily, with the front panel buttons and ScreenManager, you may want to try the adjustments described in this section.

1. From the Tools Menu on Signa Open a C-Shell.
2. Type: **[toolchest&]**. A pulldown menu will appear in the upper left-hand portion on the display.

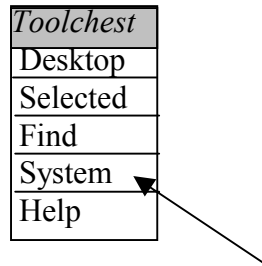

TOOLCHEST MENU
ILLUSTRATION A-3

3. Select **[System]** with the Right mouse button.
4. Select **[Confidence Tests]** from the extended menu. A “confidence test” pop-up will appear after a few seconds.
5. From the “confidence test” pop-up, select the **[Monitor Icon]**. A monitor calibration menu will appear on the screen.
6. Select **[Focus]** from the "Test Options" menu by using the **Tab** key.
7. Put the mouse pointer on the "Test Options" Menu. Click the **Middle mouse button** to toggle (Hide) the "Test Options" menu.
8. Push the auto-adjustment button on the front of the monitor. This should setup Focus, Horizontal, Vertical Centering, sync to the proper Clock Rate and monitor Phase.
9. Observe the test pattern displayed, it should now be centered and in focus. This should be all that is necessary to adjust the display controllers' output to match the LCD monitor.
10. Toggle the “monitor calibration” toolbar back on by selecting the middle mouse. Select the grayscale menu option.

11. Toggle the menu back off by selecting the middle mouse again.

A-4 Setting up LCD Display for Contrast/Brightness. Using LX Calibration Tools From Toolchest (Alternate)

This alternative procedure uses the Monitor Calibration tools and patterns. Steps 1 through 4 should be done while observing the image for crisp lines, overall uniformity of pattern, and to setup the LCD monitor so it is at its brightest level without "Blooming the image or adding distortions". The intent of this section is to achieve the best image appearance you can with the LCD. At the completion of this section you should check the display against industry standard SMPTE pattern. (See Section 7 of this procedure - LCD CALIBRATION FOR OPTIMUM IMAGE VIEWING)

1. Select "**Contrast/Brightness**" button and **push enter**.
2. Adjust brightness to maximum level **100%**.
3. Look at the monitor and adjust the Contrast and Brightness to optimize the test clarity of the test pattern. This is an iterative process between both settings.
4. When satisfied with the displays' contrast and brightness setting is properly achieved, **push the enter button to save the adjusted Contrast/Brightness settings**.
5. Exit the Monitor Calibration by selecting "**Quit**".
6. Select "**File**" on the Confidence Test Window and choose "**Exit**".
7. **Click on the word "Toolchest"** at the top of the menu with the **Right mouse button** and select "**Close**".
8. Exit the C-Shell by typing: **Exit [Enter]**

REVISION HISTORY

| REV | DATE | AUTHOR | PRIMARY REASONS FOR CHANGE |
|-----|---------------|---------------|--|
| A | July 18, 2001 | D. Hofstetter | Initial Version. |
| 0 | Nov 8, 2001 | D. Hofstetter | Changed Section 5. Added gamma table installation. |
| 1 | Dec 14, 2001 | D. Hofstetter | Changed Monitor Frequency Rate to 72Hz for all monitor configurations. |
| | | | |
| | | | |