

TABLE OF CONTENTS

Table of Contents 1

1.Required Tool 2

2.Swing Table Elevation Theory 2

3.Table Height Adjustment 2

 3-1.Location of the Sensor Adjustment Assembly 3

 3-2.Elevation Adjustments 3

 3-3.Table Level Check 4

 3-4.Mechanical Lower Limit Check 5

 3-5.Mechanical Lower Limit Adjustment 6

 3-6.Mechanical Upper Limit Adjustment 7

 3-7.Mechanical Upper Limit Adjustment(Continued) 8

 3-8.Electronic Height Adjustment (SRI Limit) 9

 3-9.Replacing the covers on the table 10

Revision History 11



THE SWING TABLE ELEVATION MOTION IS ACHIEVED BY A SCISSORS ACTION OF TWO FRAMES THAT CAN CAUSE SEVERE TRAUMA AND POSSIBLE DISMEMBERMENT. NEVER PLACE ANY HANDS OR FINGERS BETWEEN THESE FRAMES WITHOUT BLOCKING THE TABLE IN THE UP POSITITON.

1. Required Tool

- Level Gauge
- Ruler(15 cm)
- Ruler(100 cm)
- Metric hexagon wrench set.
- Small Flat blade screwdriver.
- Small Phillips screwdriver.
- Voltmeter

2. SWING TABLE ELEVATION THEORY

- The Swing Table moves up and down by depressing the foot pedals located on either side of the table. These foot pedals are located in the front of the Swing Table nearest to the magnet.
- The purpose of this up and down travel is to provide the operator and patient convenience when loading the table.
- The elevation motion it self is provided by a 38vdc screw-gear type drive mechanism that is assisted by two gas shocks. These gas shocks have more than enough power to drive the table to the uppermost position should the mechanical drive mechanism fail.
- The Position of the table is critical for scan operation. If the table is not in the full up position, the scanner will pause and the error log will indicate that the table is not up. The signal that allows for the system to know the position of the table is controlled by a single adjustment of an optical sensor that is fed to the SRI (Scan Room Interface) and then back to the ISE (Integrates System Electronics). In addition, there are two other optical sensors that are used to setup the Mechanical limits of the table. The same type of adjustment is made to set the Mechanical UP and the Mechanical DOWN limit of the table.
- Due to small variations in siting, these adjustments must be checked, and occasionally adjusted during the Swing Table Installation. Any further adjustment would be necessary only if the elevation mechanism is replaced or if the optical sensors fail.
- The Elevation Adjustment should be checked periodically, to insure that the correct table height is maintained.

3. TABLE HIGHT ADJUSTMENT

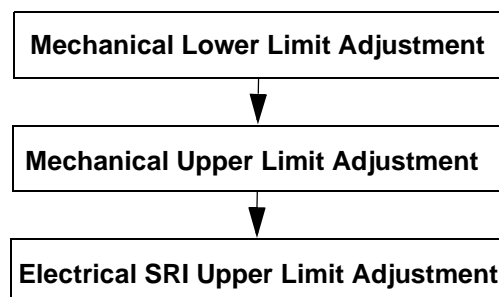

3-1 Location of the Sensor Adjustment Assembly

The sensor Adjustment assembly is located near the front right side of the table when looking at the magnet from the rear of the table. It is necessary to remove the lower cover by removing the screw fasteners on each end of table.

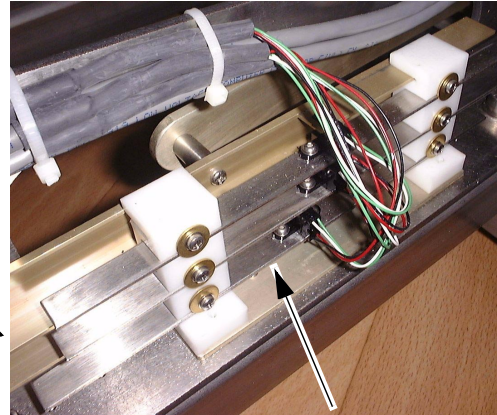
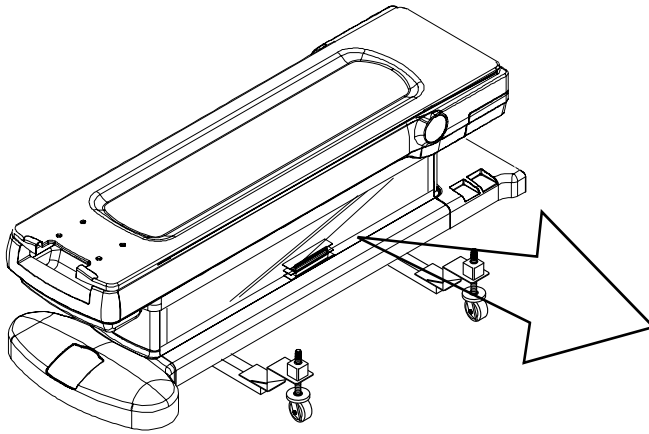

Sensor Adjustment Assembly

SENSOR ADJUSTMENT ASSEMBLY
ILLUSTRATION 1

3-2 Elevation Adjustments

NOTE:

The following procedures should be done after the table has been installed and leveled properly on site. If the table is not level prior to performing the Elevation Limit Adjustments you will need to repeat the procedure unnecessarily at a later date and could cause aesthetic damage to the magnet enclosure.

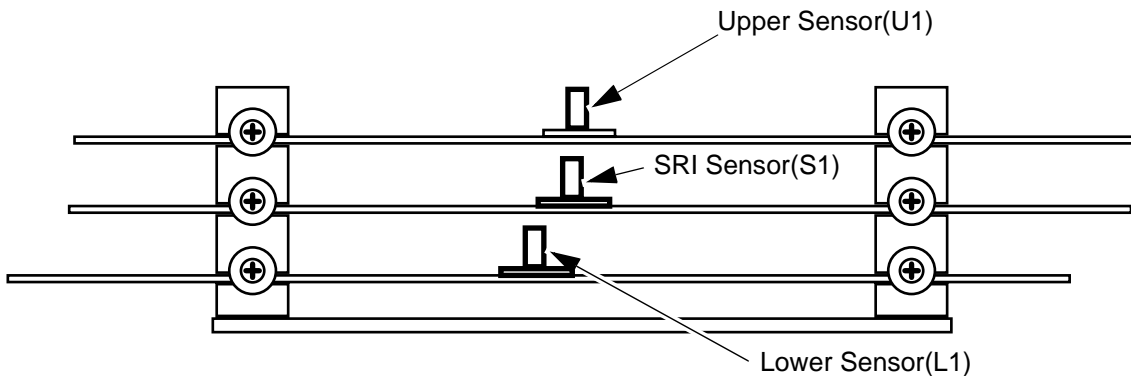

SENSOR ADJUSTMENT ASSEMBLY
ILLUSTRATION 2

3-3 Table Level Check

Table leveling is achieved by proper placement of the correct amount of shims under the table Rail during the initial Swing Table Installation. There are no adjustments on the Swing Table wheels. Shimming the Swing Table Rail is the sole method used to adjust table level FRONT to BACK (ANTERIOR to POSTERIOR) and Left to right. If re-shimming the table is required to achieve proper level, it will be necessary to perform all of the Mechanical Table Installation procedure alignments before adjusting the Sensor Adjustment Assembly. Failure to do perform the Installation procedures and measurements will result in table misalignment and severe problems achieving proper image quality.

1. Place at least a 2 foot level on the side of the table. Insure that the table is level, front to back. If you find this out of adjustment you will need to re-shim the Swing Table Rail. It will be necessary to perform all of the Mechanical Table Installation procedure alignments. Refer to the Swing Table Installation procedure.

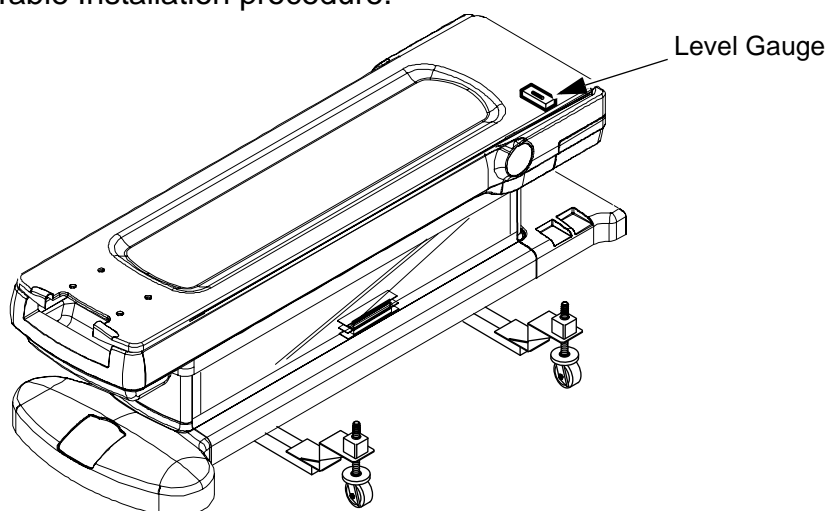

**SENSOR ADJUSTMENT ASSEMBLY
ILLUSTRATION 3**

2. Check the level of the table Left to right at the approximate center of the Swing Table. If you find this out of adjustment you will need to re-shim the Swing Table Rail. It will be necessary to perform all of the Mechanical Table Installation procedure alignments. Refer to the Swing Table Installation procedure.

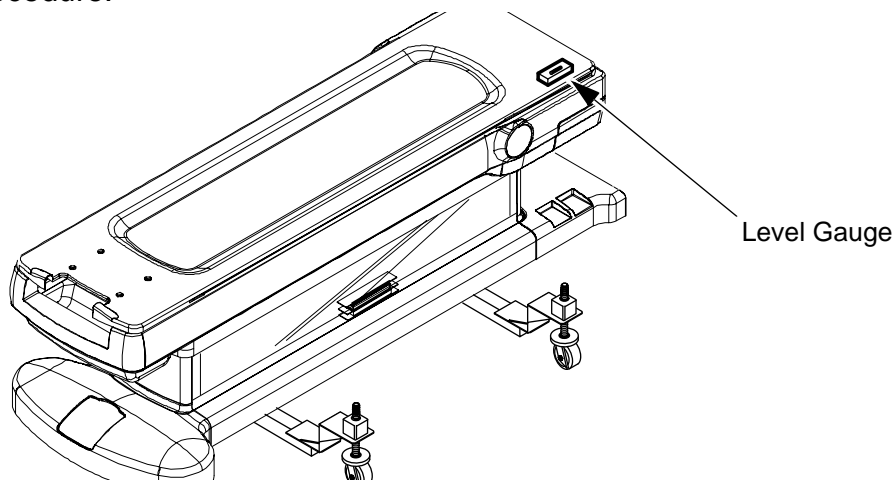

**SENSOR ADJUSTMENT ASSEMBLY
ILLUSTRATION 4**

3-4 Mechanical Lower Limit Check

1. Using the foot pedal, drive the table to its lowest position.
2. Using a 100cm Ruler and a 15cm Ruler, measure the measurement from the cradle roller rail to the Swing Table wear plate or finished floor. In the absolute down position, this measurement should be 65.5cm +/- 5mm (Approximately 25-7/8"). If this is not correct, Adjust the Lower Limit sensor (See Section 3-1-5 Mechanical Lower Limit Adjustment).

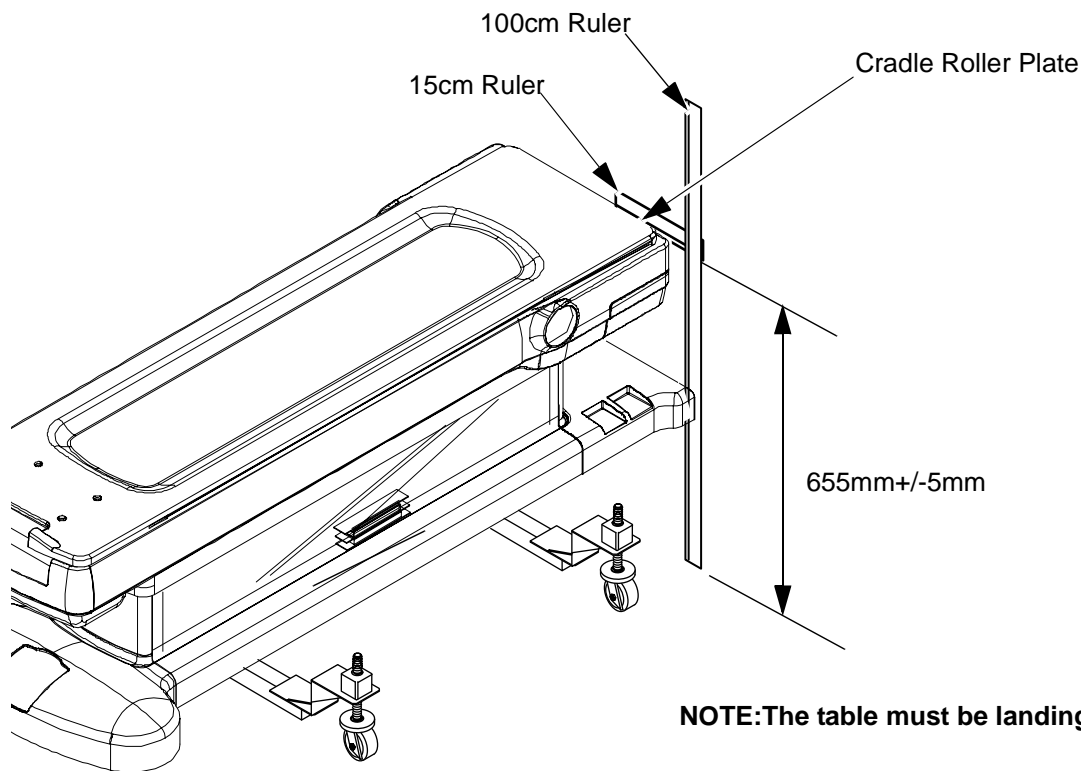

**TABLE LOWER LIMIT CHECK
ILLUSTRATION 5**

3-5 Mechanical Lower Limit Adjustment

The Lower sensor (L1) is permanently mounted to an adjustable slide plate. It is necessary to adjust this slide plate left or right as necessary to achieve 65.5cm +/- 5mm (25-7/8") height from the table wear plate or finished floor.

1. Loosen these two screws and adjust the slide plate and sensor to the LEFT TO DECREASE the table height or to the RIGHT TO INCREASE the table height.

NOTE:

When tightening two screws after adjustment, tighten two screws holding the plate by another hand.

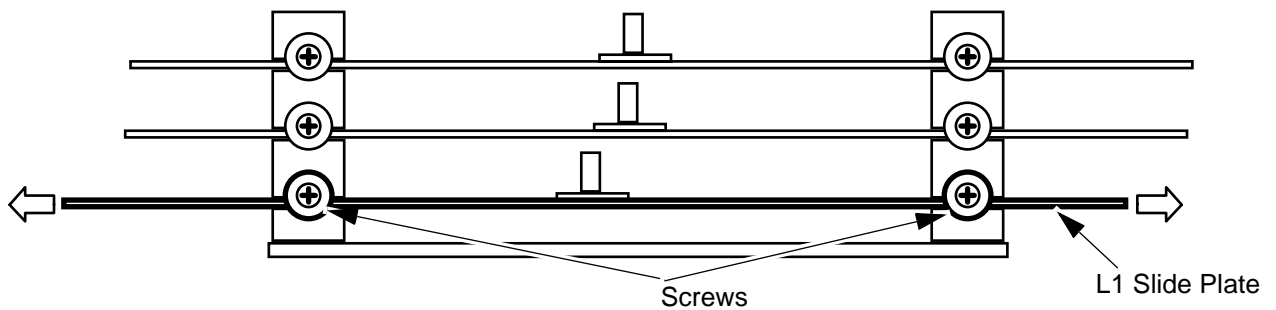

**SENSOR ADJUSTMENT
ILLUSTRATION 6**

2. Using a 15cm ruler and 100cm ruler, measure the measurement from the cradle roller rail to the Swing Table wear plate or finished floor. In the absolute down position, this measurement should be 65.5cm +/- 5mm (Approximately 25-7/8"). Re-check the measurement as necessary.
3. When your measurement is within the required distance, complete the adjustment by tightening the screws.

NOTE:

A 1mm adjustment to the sensor will cause a 3mm difference in the elevation of the table.

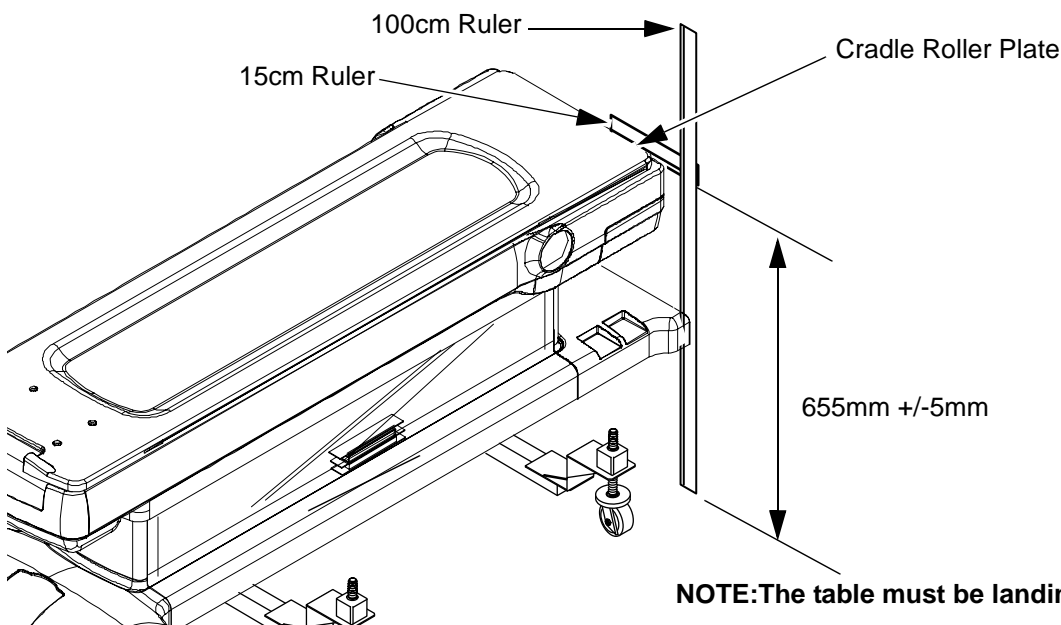

NOTE:The table must be landing to floor.

**TABLE LOWER LIMIT CHECK
ILLUSTRATION 7**

3-6 Mechanical Upper Limit Adjustment

This adjustment is done to insure that the table and the magnet are at the same level. If this adjustment is not done properly the cradle rollers will collide with the magnet rather than transition smoothly with the magnet surface.

Due to the differences in screen room floor construction you should adjust the table height to achieve the smoothest cradle transition between the table cradle and the magnet surface.

The specifications as listed should get you very close to this.

The final adjustment, Electronic Height Adjustment (SRI High Limit) in Section 3-1-8, will be used to further fine-tune this transition between the cradle and the magnet. Siting may require several adjustments to achieve the best result.

The Upper sensor (U1) is permanently mounted to an adjustable slide plate. It is necessary to adjust this slide plate left or right as necessary to achieve 6 mm +/- 1mm clearance between A(table roller plate) and B(magnet floor).

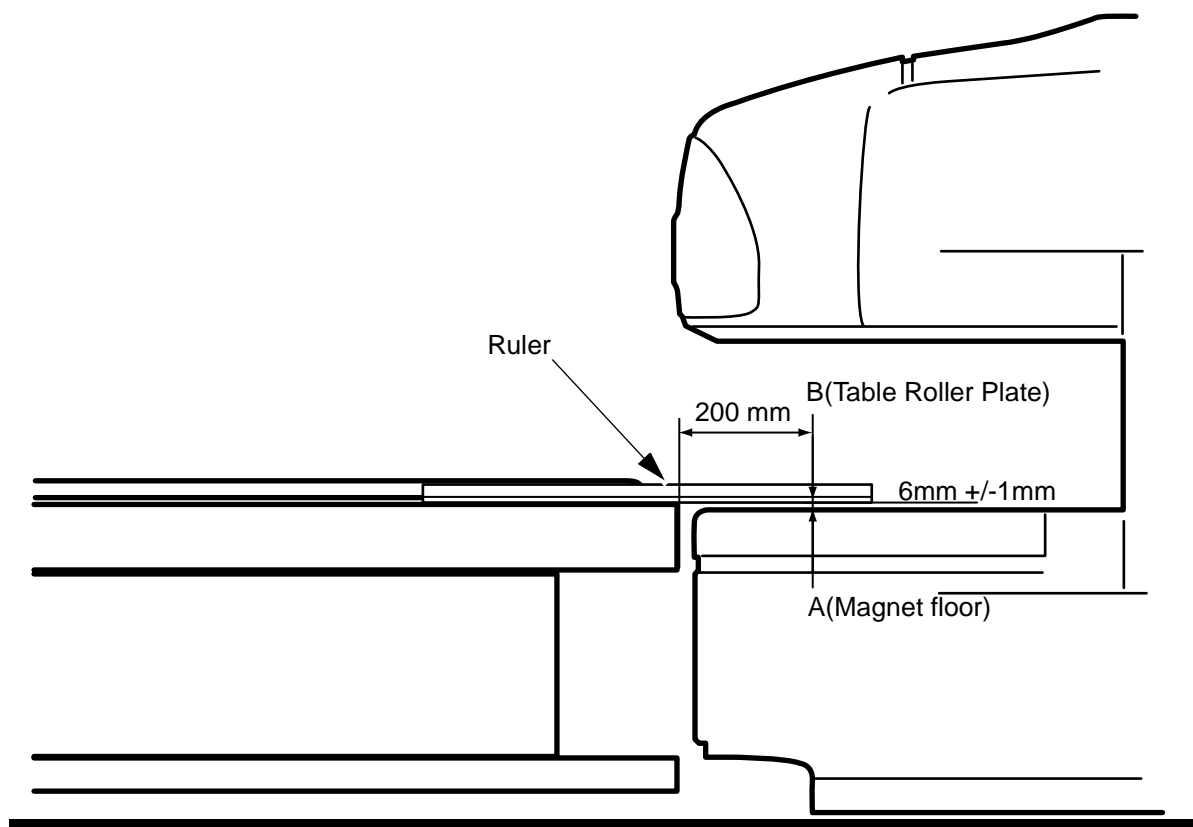

TABLE LOWER LIMIT CHECK
ILLUSTRATION 8

3-7 Mechanical Upper Limit Adjustment(Continued)

1. Loosen these two screws and adjust the slide plate and sensor to the LEFT TO DECREASE the table height or to the RIGHT TO INCREASE the table height.

NOTE:

When tightening two screws after adjustment, tighten two screws holding the plate by another hand.

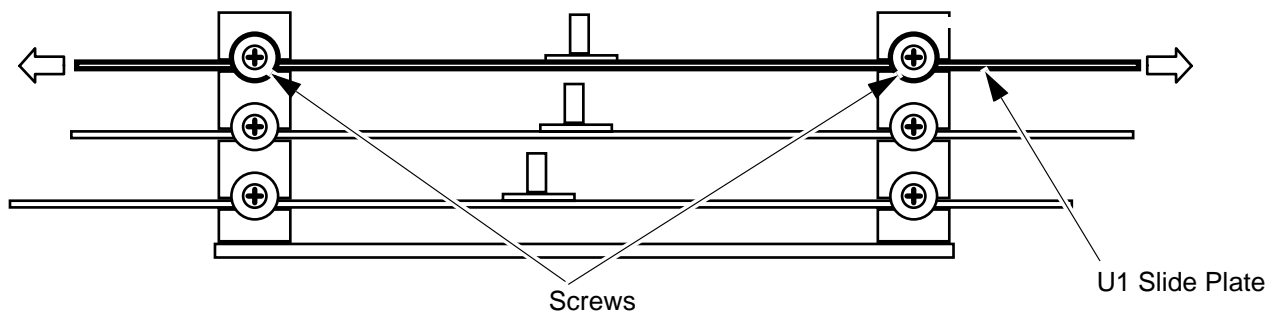

SENSOR ADJUSTMENT
ILLUSTRATION 9

2. Using 100cm Ruler and 15cm Ruler,measure the clearance between A and B. There should be clearance of 6mm +/-1mm.
3. When your measurement is within the required distance, move the cradle in and out and observe the cradle to magnet transition. It should be smooth and not drop or collide with the magnet surface. When satisfied that this is accomplished, complete the adjustment by tightening the screws.

Note:

A 1mm adjustment to the sensor will cause a 3mm difference in the elevation of the table.

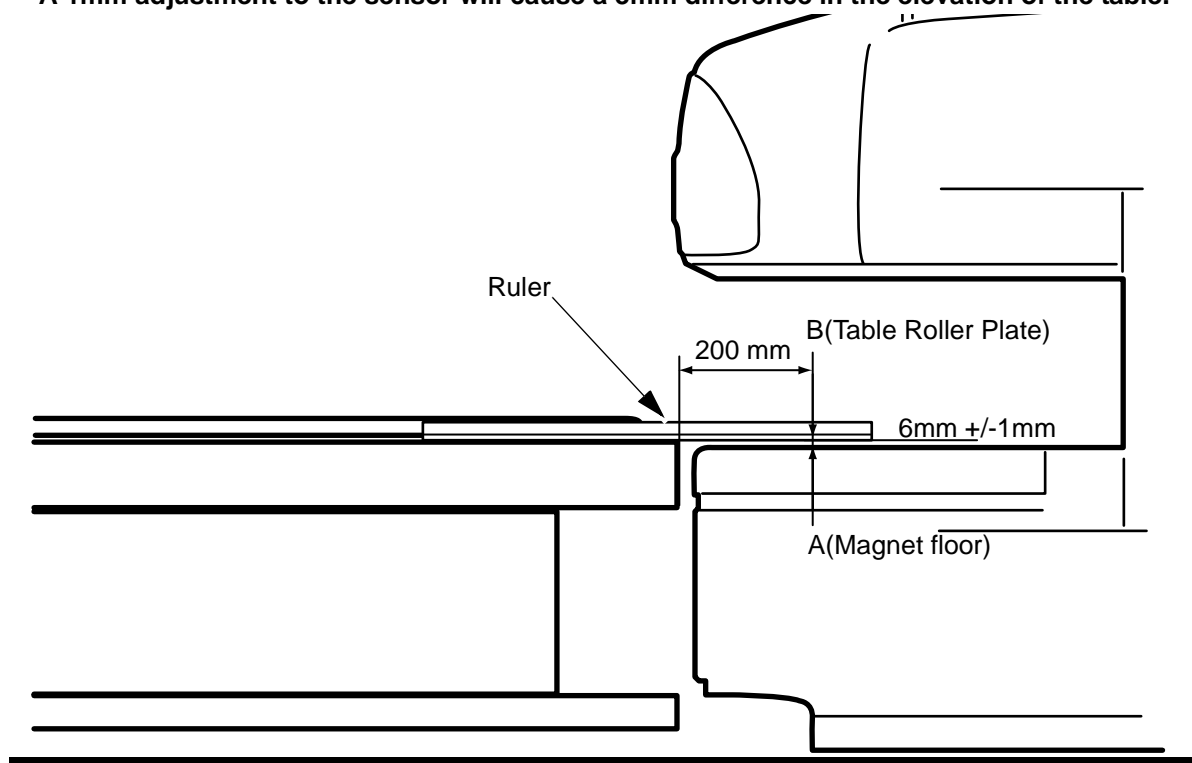

TABLE LOWER LIMIT CHECK
ILLUSTRATION 10

3-8 Electronic Height Adjustment (SRI Limit)

This check should be performed to insure that the system knows when the table is in the calibrated up position. The SRI is informed of the table Up Position by a separate SRI sensor. This signal is necessary to allow the cradle to move freely into the magnet. When this sensor is correctly set, the SRI informs the system that the cradle can be released and that scan can take place. The setting of this sensor should be slightly below the Mechanical Upper Limit to insure full travel of the elevation drive system.

The SRI Upper Limit sensor (S1) is permanently mounted to an adjustable slide plate. It is necessary to adjust this slide plate left or right as necessary to achieve the proper SRI enabling signal. The SRI Upper Limit Sensor plate should be adjusted to activate BEFORE the Mechanical Upper Limit Sensor. This is achieved by loosening the screws and adjusting the SRI Sensor plate 2mm to the left.

This final adjustment is done to insure that the table and the magnet are at the same level, and slightly below the actual mechanical height limit of the elevation drive system. If this adjustment is not done properly the cradle rollers will collide with the magnet rather than transition smoothly with the magnet surface. Due to the differences in screen room floor construction you should adjust the table height to achieve the smoothest cradle transition between the table cradle and the magnet surface. Siting may require several adjustments to achieve the best result.

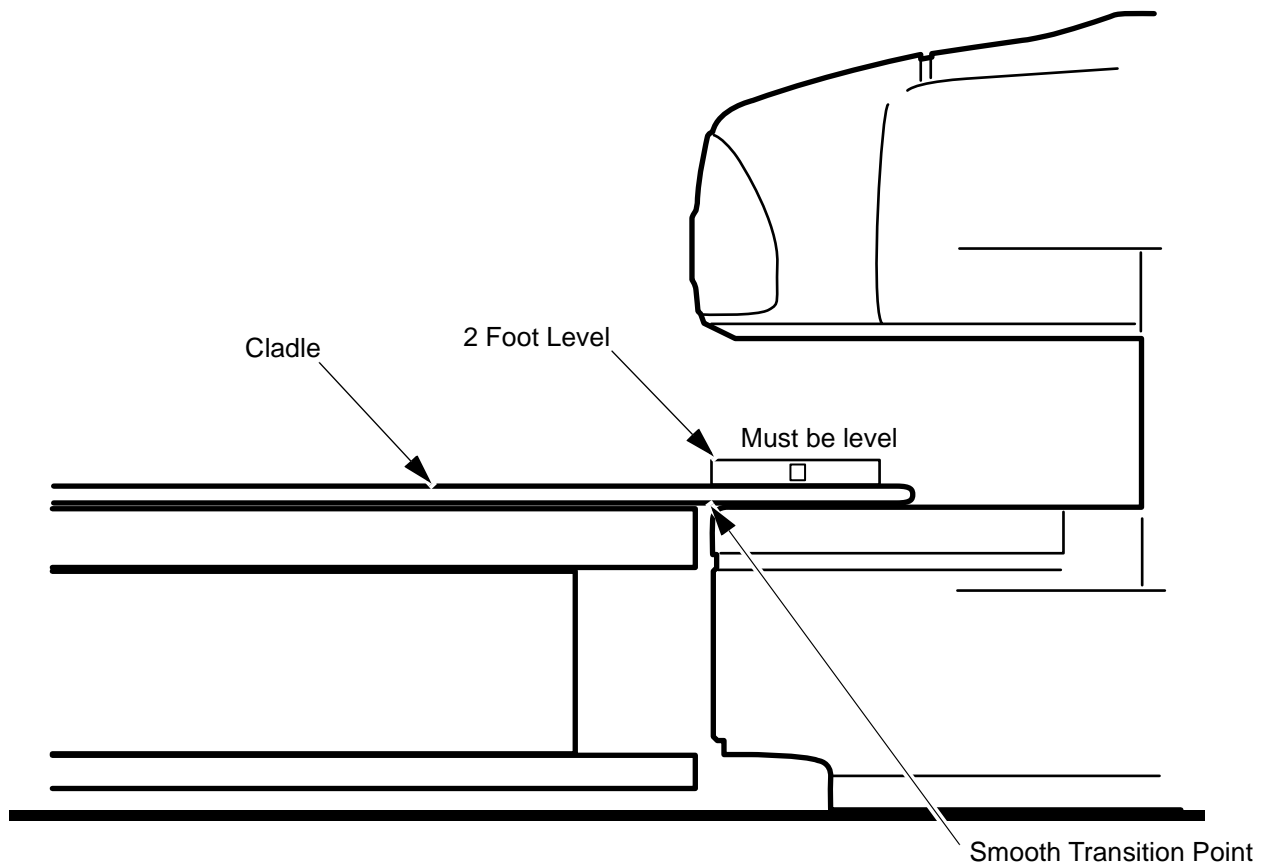

CRADLE/MAGNET INTERFACE
ILLUSTRATION 11

3-9 Electronic Height Adjustment (SRI Limit)(Continued)

The SRI Sensor (S1) is permanently mounted to an adjustable slide plate. It is necessary to adjust this slide plate left or right as necessary to achieve a properly adjusted SRI signal.

1. Loosen these two screws and adjust the slide plate and sensor to the left approximately 2mm to DECREASE the table height.

NOTE:

When tightening two screws after adjustment, tighten two screws holding the plate by another hand.

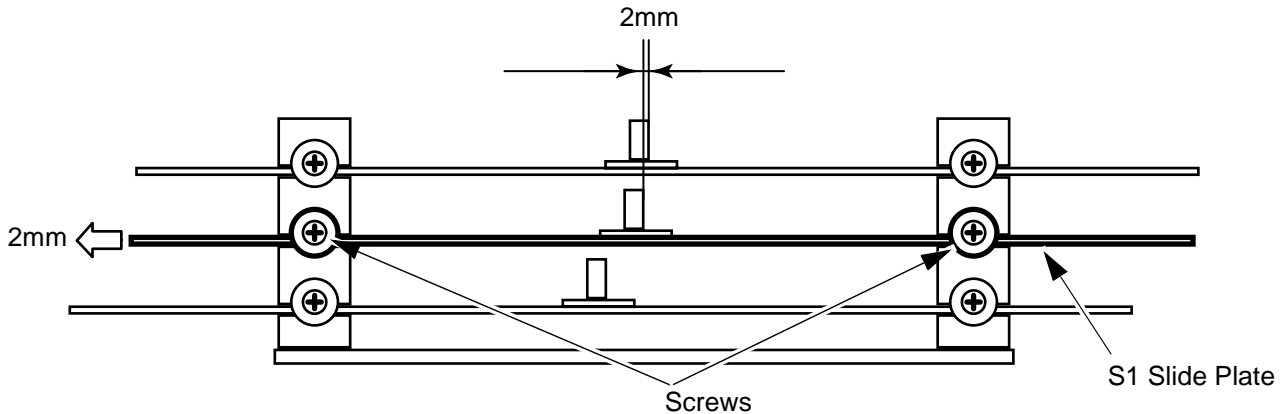

SENSOR ADJUSTMENT
ILLUSTRATION 12

2. When your measurement is within the required distance, you should see the status indicator on the front of the magnet indicating that the table is in the electronic up position. Verify this by moving the cradle in and out completely. Observe the cradle to magnet transition. It should be smooth and not drop or collide with the magnet surface. When satisfied that this is accomplished, complete the adjustment by tightening the screws.

Note:

A 1mm adjustment to the sensor will cause a 3mm difference in the elevation of the table.

3-10 Replacing the covers on the table

Once the Swing Table Sensor adjustments/ Checks are complete replace the table covers with the screws provided.

Revision History

Rev	Date	Author	Primary Reasons For Change
0	Mar 15, 2001	K.Tsumagari	Initial Release