

Rev 0

TABLE OF CONTENTS

TABLE OF CONTENTS.....	1
1-Power ON.....	2

Rev 0

1. POWER ON

1. Notify field service and other installation personnel that are working at the site that the PDU main disconnect locks and tags will be removed so PDU power can be turned on.
2. Restore power to the PDU from main disconnect.
3. Turn the Main Input Circuit Breaker to the ON Position(Vertical Position).
4. Turn the each breakers ON.
 - a. Turn the GRADIENT breaker ON. Verify that the FAN of GPS is working.
 - b. Turn the System Cabinet breaker ON. Verify that the FAN of SC is working.
 - c. Turn the SSM breaker ON. Verify that the FAN of SSM is working.
 - d. Turn the OC/HOST PC breaker ON.
 - Turn the Host computer power ON and verify that the Host Computer boot up.
 - Turn the PC power on and verify that the PC boot up.
 - e. Turn the TCU breaker ON. Verify that the FAN of TCU is working.

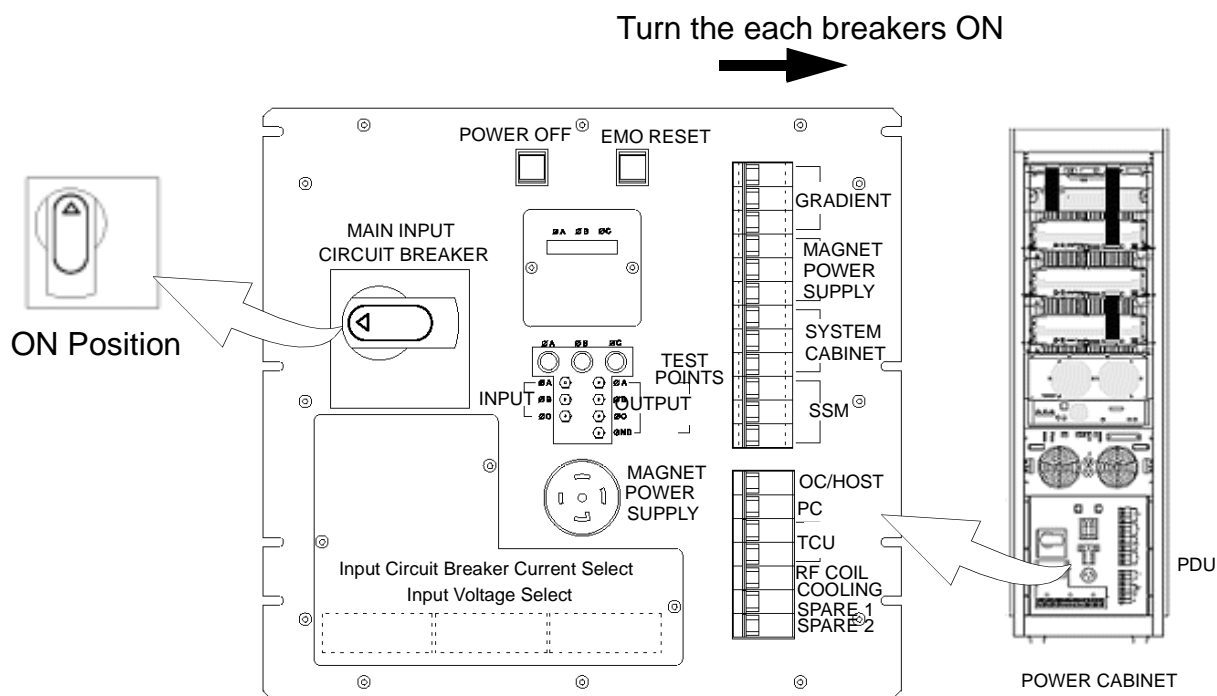

**PDU FRONT PANEL
ILLUSTRATION 1-1**

Rev 0

Revision History

Rev	Date	Auther	Primary Reasons For Change
0	Dec 13, 2000	Y. Masumo	Initial Release