

MAGNET COVER INSTALLATION

VOLUME 1

TABLE OF CONTENTS

Table of Contents 1

1.Preparation 2

2.Determine Pac Remote Interface Location 3

3.Top Cover 4

4.Apron Cover 6

5.Side Cover 7

6.Front Cover 18

7.Post Cover 20

8.Rear Deck Plate 21

9.Post Cover Clearance Adjustment 22



FERROUS MATERIAL HAZARD! THE CRIMP TOOL, AND OTHER TOOLS AND PARTS REQUIRED FOR THIS INSTALLATION CONTAIN FERROUS MATERIAL AND WILL BE STRONGLY ATTRACTED TO MAGNET AND MAY BECOME DANGEROUS PROJECTILES. IF MAGNET IS AT FULL FIELD – KEEP ALL FERROUS TOOLS AT LEAST 10 FEET AWAY FROM THE MAGNET.

Rev 4

1. Preparation

Required Tool:

Items	Qty	Type/Parts Number	Part
Metric Allen Wrench Set	1	Non ferrous	
5mm-S Metric Allen Wrench	1	Non ferrous Short Type 46-320470P9	L-Post Cover

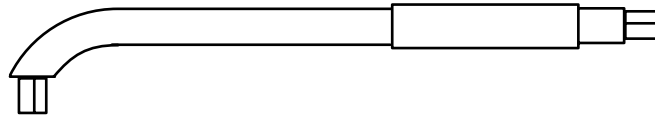

5mm-S Metric Allen Wrench

Rev 4

2. DETERMINE PAC REMOTE INTERFACE LOCATION

1. Consult with customer to determine which side of magnet PAC Remote Interface Assy should be located.

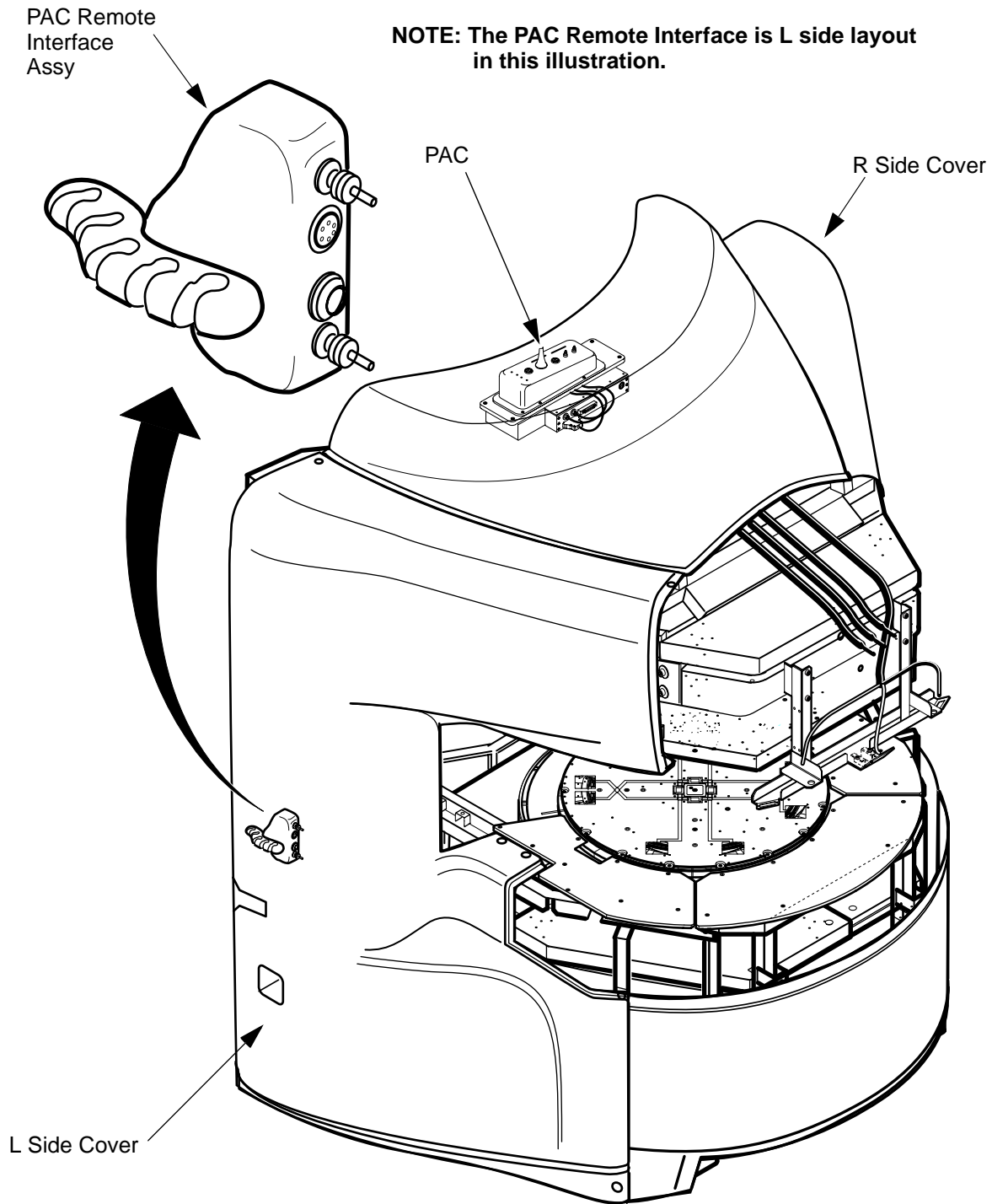

**DETERMINE PAC REMOTE INTERFACE LOCATION
ILLUSTRATION 1**

Rev 4

3. Top Cover

CAUTION

At least two people are required to install the Top Cover.

1. Install Roof Support onto the magnet top side with 4 screws using step rudder.

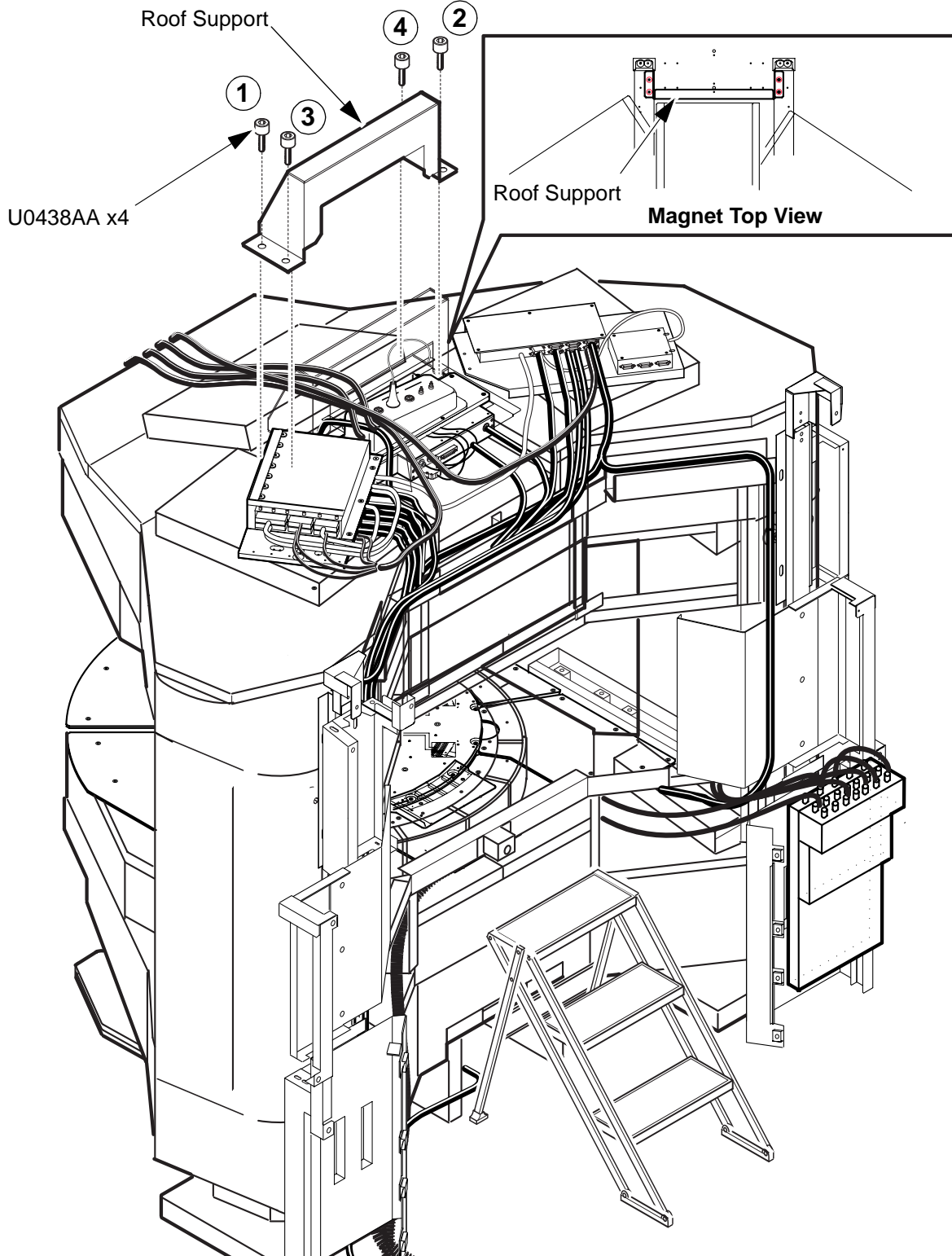

APRON COVER INSTALLATION
ILLUSTRATION 2

Rev 4

3. Top Cover(Continued)

CAUTION

At least two people are required to install the Top Cover.

2. Install Top Cover onto the frames of magnet top with 4 screws(U0438AA).

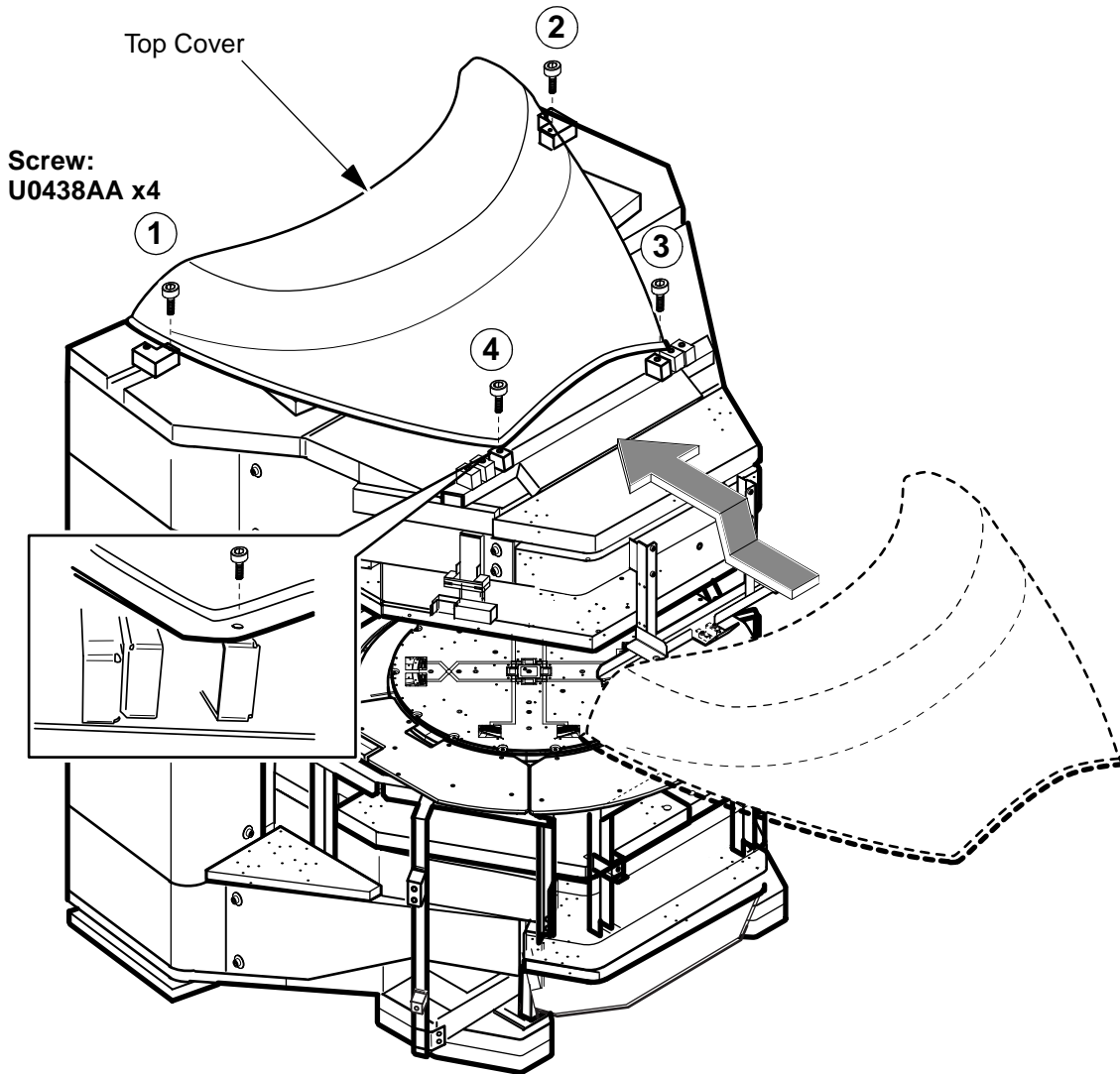

APRON COVER INSTALLATION
ILLUSTRATION 3

Rev 4

4. Apron Cover

1. Install the Apron Cover to the front and side frame of the Magnet with 6 screws(U0438AA).
2. Peel the protection film from right under side of cover, and attach three seals as illustration.

NOTE:The screw number is tightening order.

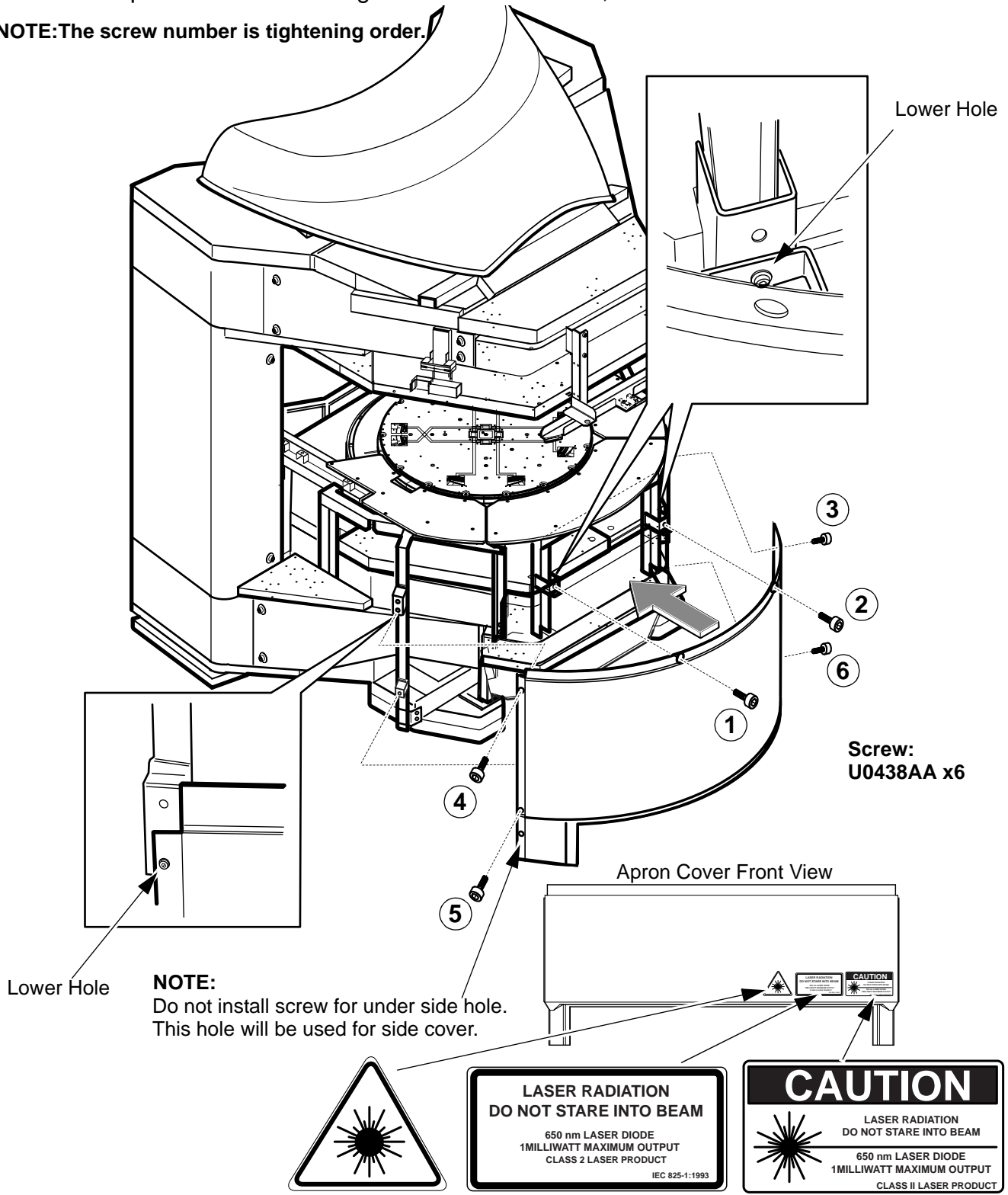

NOTE:
Do not install screw for under side hole.
This hole will be used for side cover.

Choose a seal of language of your country.

APRON COVER INSTALLATION
ILLUSTRATION 4

Rev 4

5. Side Cover

CAUTION

At least two people are required to install the Side Covers.

PAC Remote Interface Side:

1. Install PPG Cable Tube to roof support with tie-wrap.
2. Route PPG Cable Tube to insulator groove of PAC remote interface side.

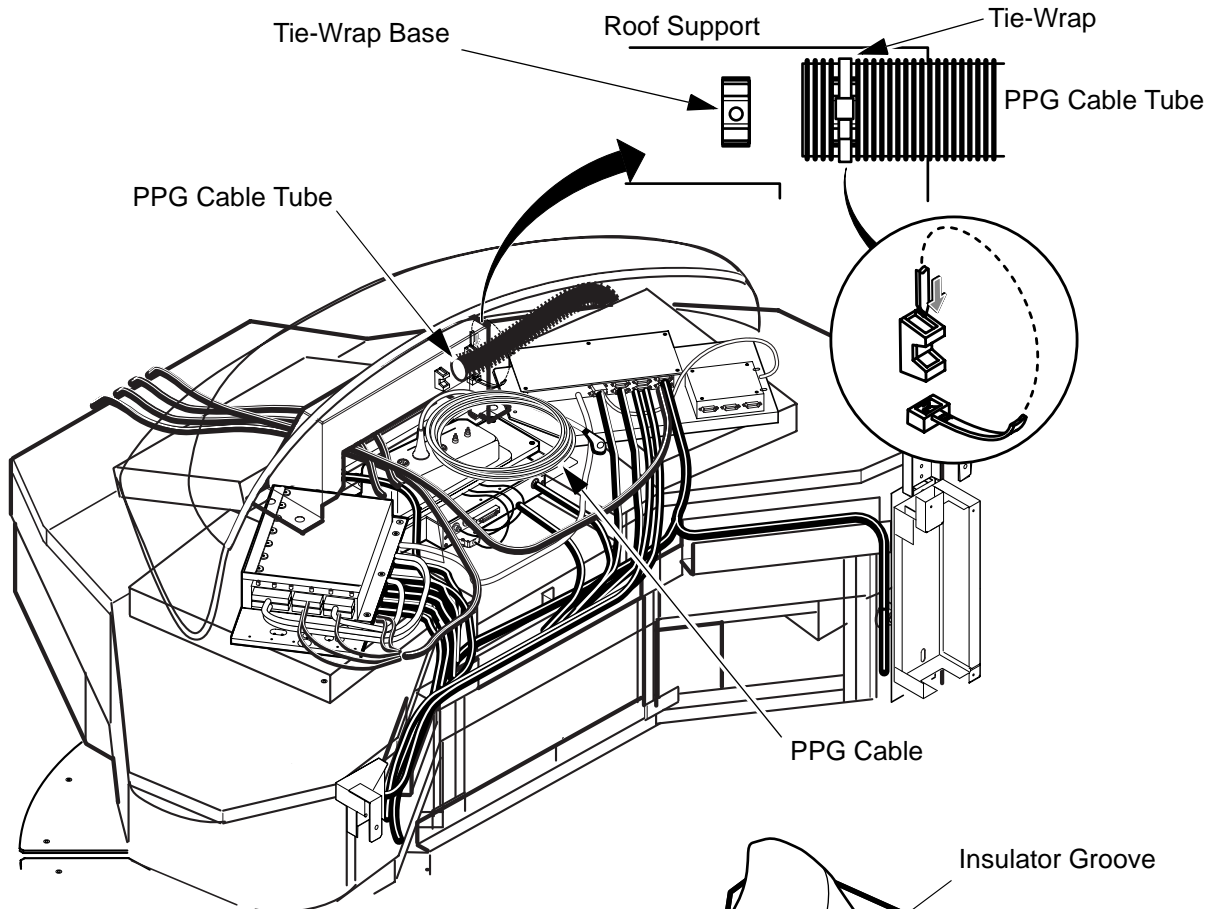

NOTE: The PAC Remote Interface is L side layout in this illustration.

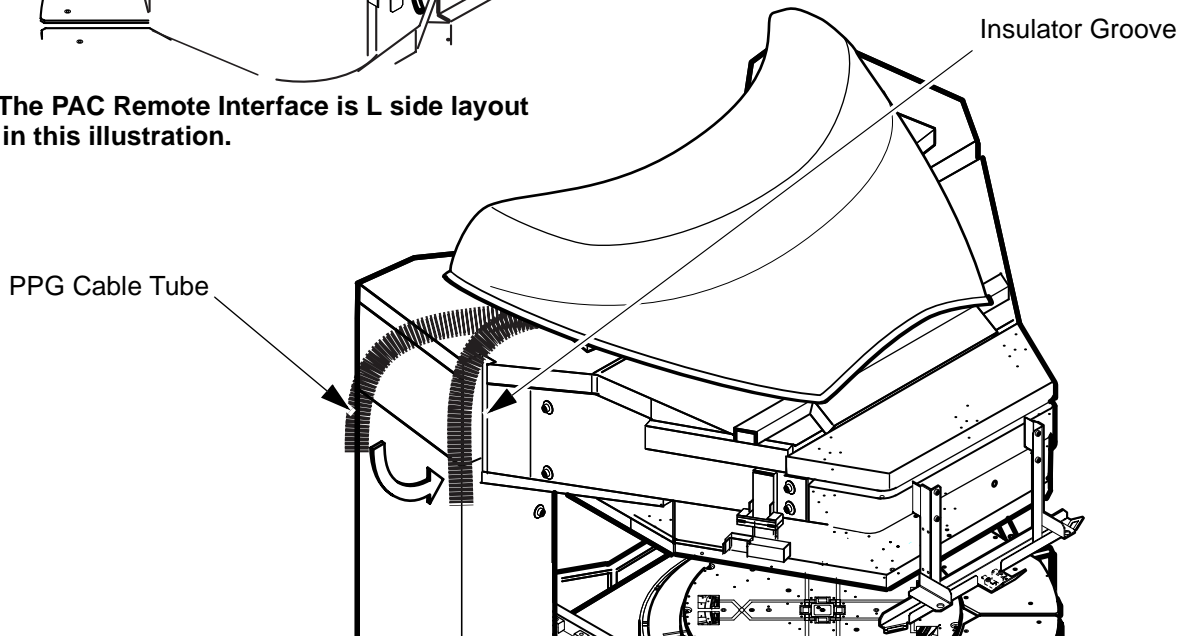

**SIDE COVER INSTALLATION
ILLUSTRATION 5**

Rev 4

5. Side Cover(Continued)

- 3. Remove PPG Cable Support by loosening 2 screws from side cover of PAC remote interface side.

NOTE: The PAC Remote Interface is L side layout in this illustration.

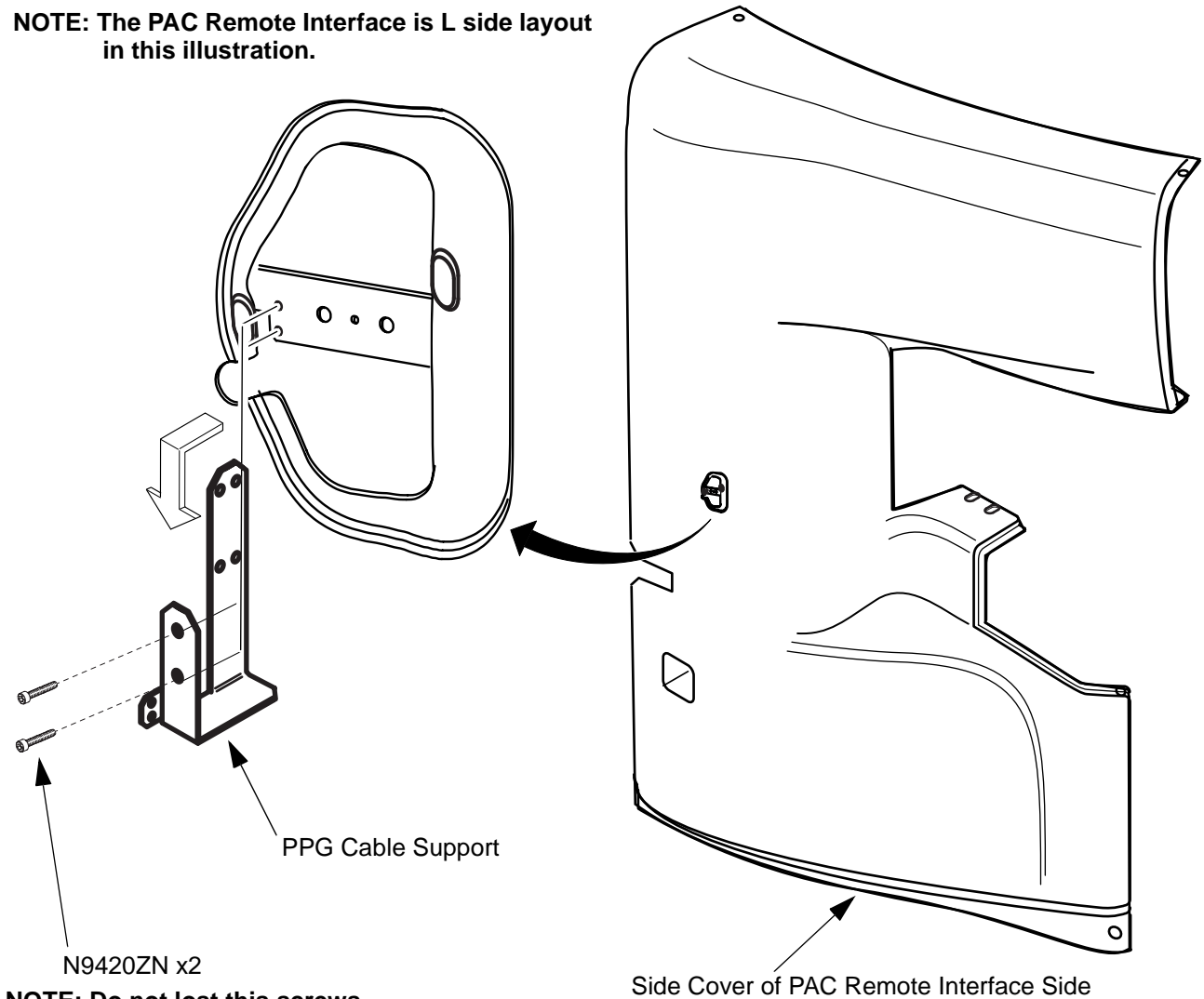

**NOTE: Do not lost this screws.
This screw will be reused.**

**SIDE COVER INSTALLATION
ILLUSTRATION 6**

Rev 4

5. Side Cover(Continued)

4. Install the PAC Remote Interface Assy to the L or R Side Cover according to site layout.
 - a. Apply tape around end of pneumatic tubes and mark "TOP" to the opposite end of the tube connected to the top connector in the Remote PAC Interface Assembly and "BOTTOM" to the tube connected to the lower connector.
 - b. Insert two (2) screws M6 x 70mm (2109873-33) screws into Clip (2221023).
 - c. Insert Clip with screws into shell as shown with top cable and tube above Clip and bottom cable and tube below.
 - d. Hold in place by inserting provided M4 screw thru slot and turning about 3 or 4 turns into Clip.

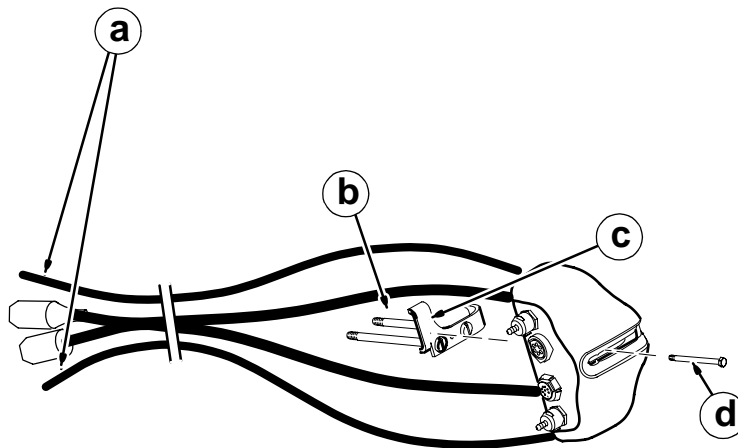

PREPARE CABLES AND TUBES FOR ROUTING
ILLUSTRATION 7

- e. Make sure each side of clip is mounted behind housing blocks.

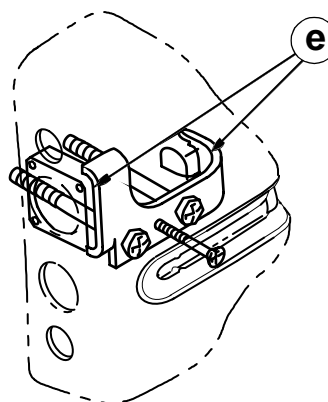

POSITION REMOTE PAC INTERFACE MOUNTING CLIP
ILLUSTRATION 8

Rev 4

5. Side Cover(Continued)

- 5. Fix cables and tubes of PAC Remote Interface to inner side of side cover with 2 tie-wraps, then keep clearance approx.100mm between PAC remote interface and side cover outside.
Note:Top two cables will be routed thru top opening and bottom two cables will be routed thru lower opening.

NOTE: The PAC Remote Interface is L side layout in this illustration.

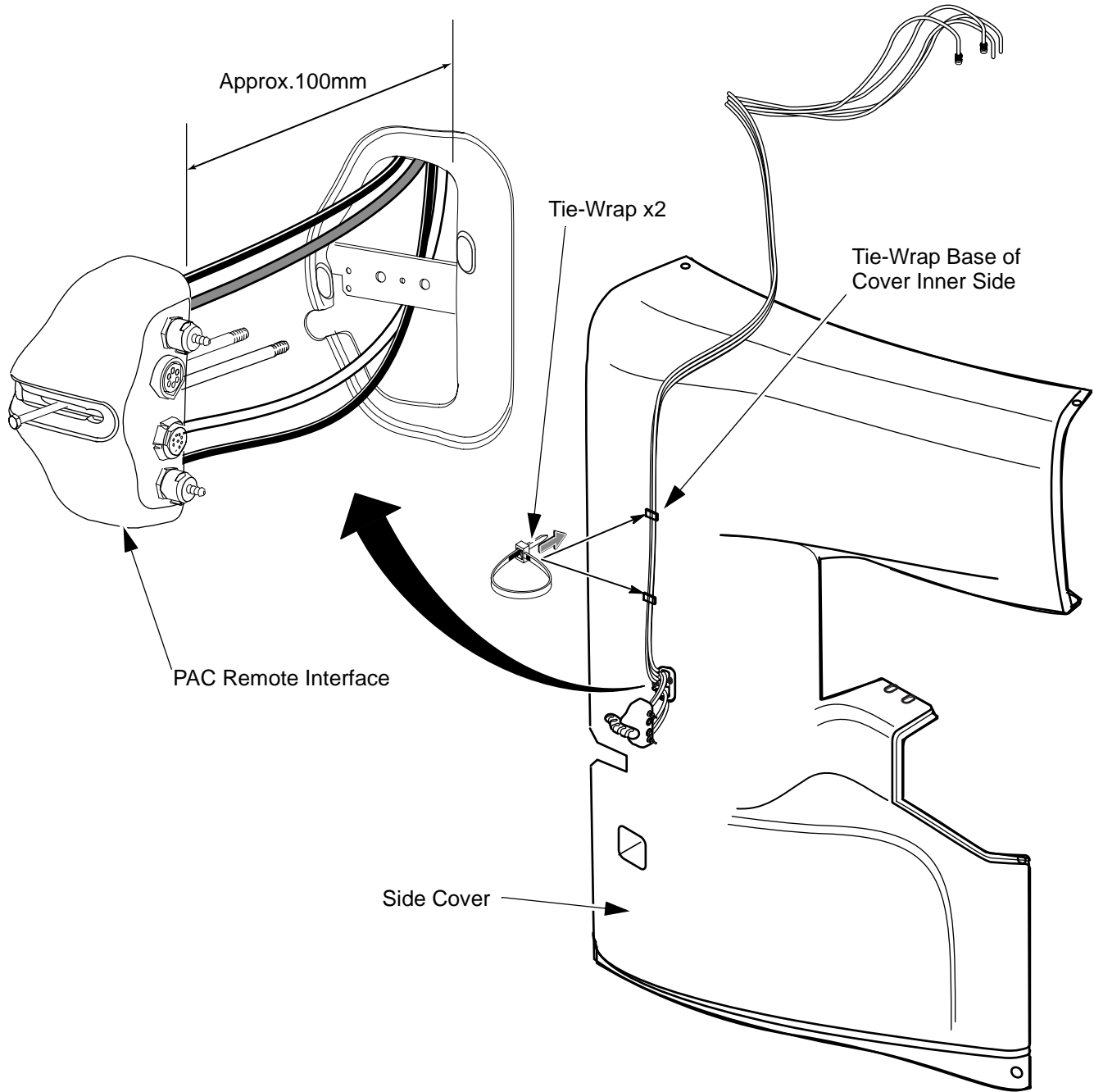

**SIDE COVER INSTALLATION
ILLUSTRATION 9**

Rev 4

5. Side Cover(Continued)

- 6. Put PAC remote interface cables and tubes of side cover onto the magnet.
- 7. Install Side Cover of PAC remote interface side to the magnet with 2 screws of cover upper side. This side cover installation is temporary fixing.

CAUTION:
Be careful not to damage cable when installing side cover.

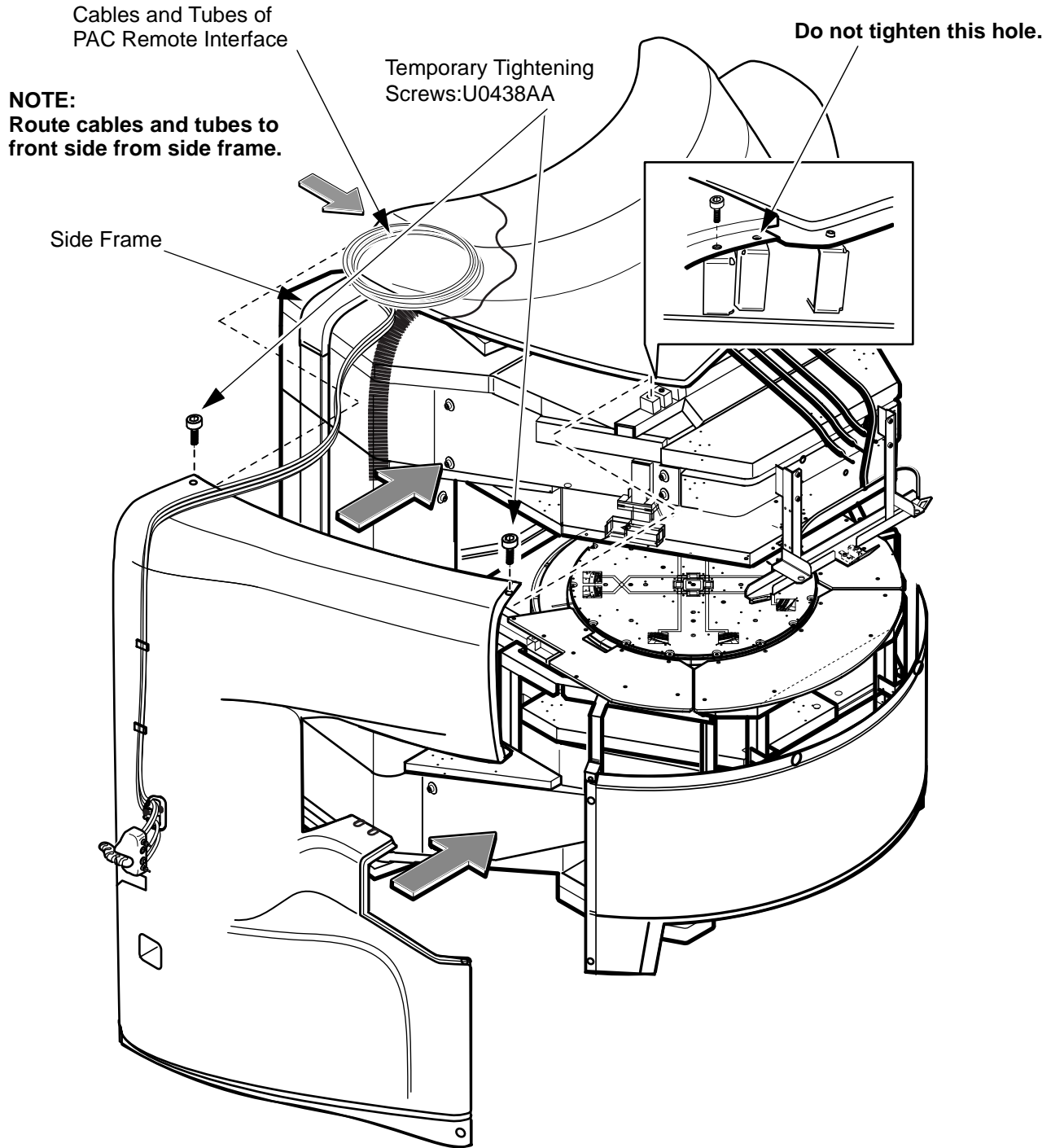

SIDE COVER INSTALLATION
ILLUSTRATION 10

Rev 4

5. Side Cover(Continued)

- 8. Mark 1900 +/-10mm position from probe side of PPG cable with tape using ruler.
- 9. Insert PPG Cable into tube until cable marked position.
- 10. Draw PPG Cable Probe from bottom opening of PAC remote interface hole.
- 11. Send PPG Cable from upper magnet side so that there is not rest.

Caution: When inserting PPG cable, protection cap must be installed to PPG probe.

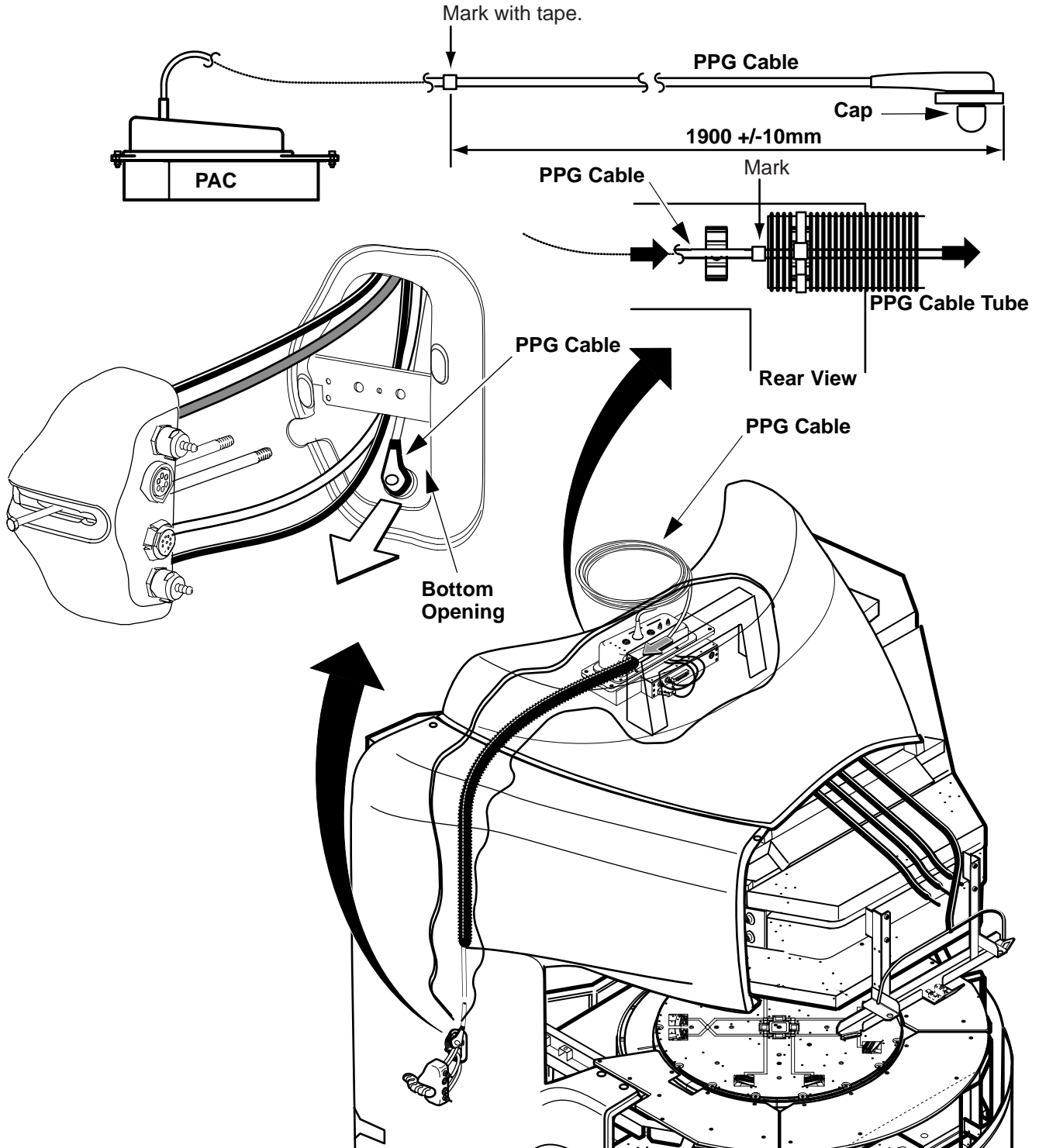

**SIDE COVER INSTALLATION
ILLUSTRATION 11**

Rev 4

5. Side Cover(Continued)

- 12. Attach grommet to PPG cable. Check that there is more than 4 m between grommet and probe of PPG cable.
- 13. Attach Cable Support to PPG cable with 3 tie-wraps(U0200AC).
- 14. Install Cable Support to side cover BRKT with removed 2 screws.

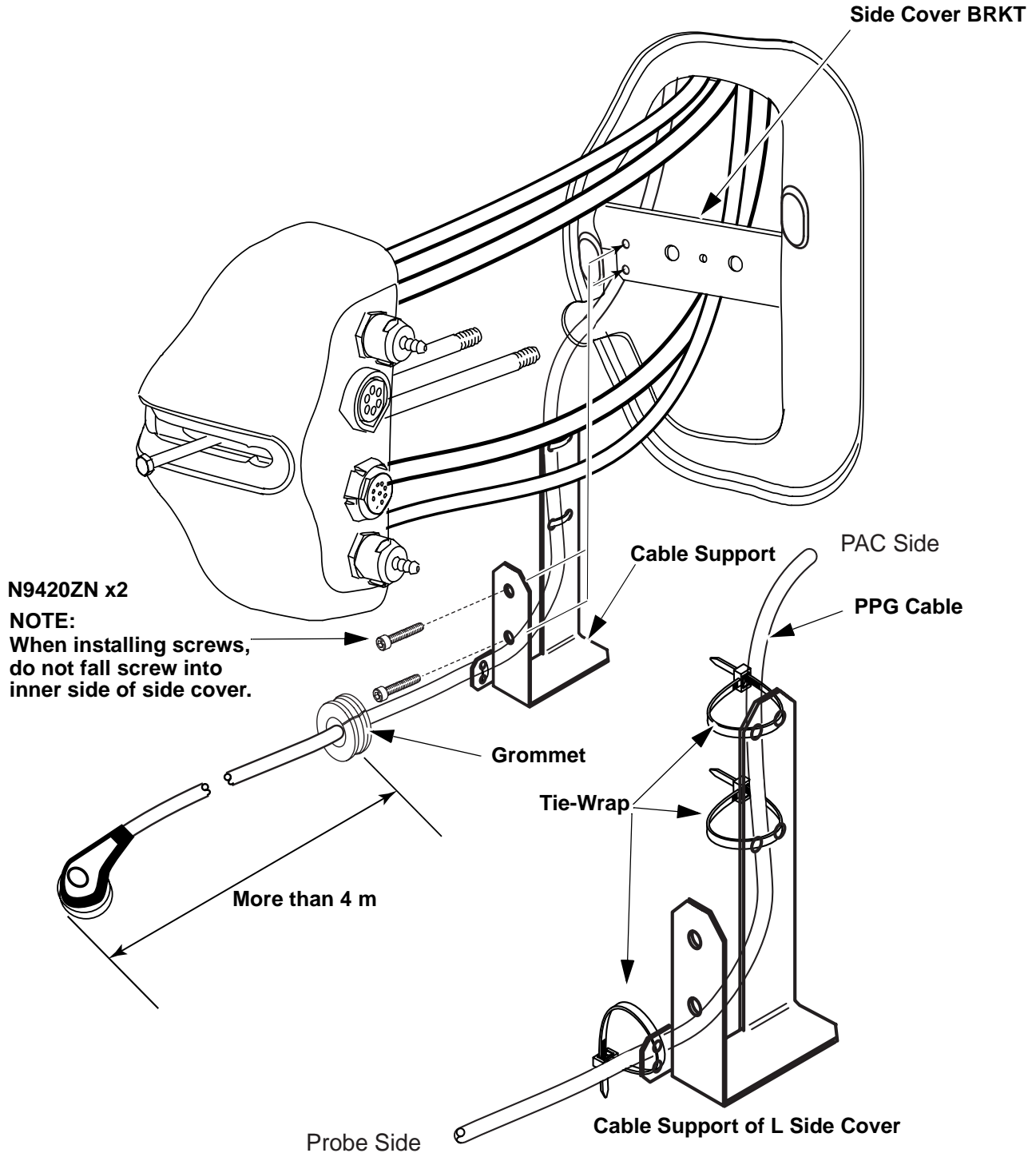

**SIDE COVER INSTALLATION
ILLUSTRATION 12**

Rev 4

5. Side Cover(Continued)

- 15. Pull PPG Cable lightly from upper magnet side.
- 16. Fix PPG Cable to roof support with tie-wrap.
- 17. Connect cables and tubes of PAC Remote Interface Assy to PAC on the magnet.

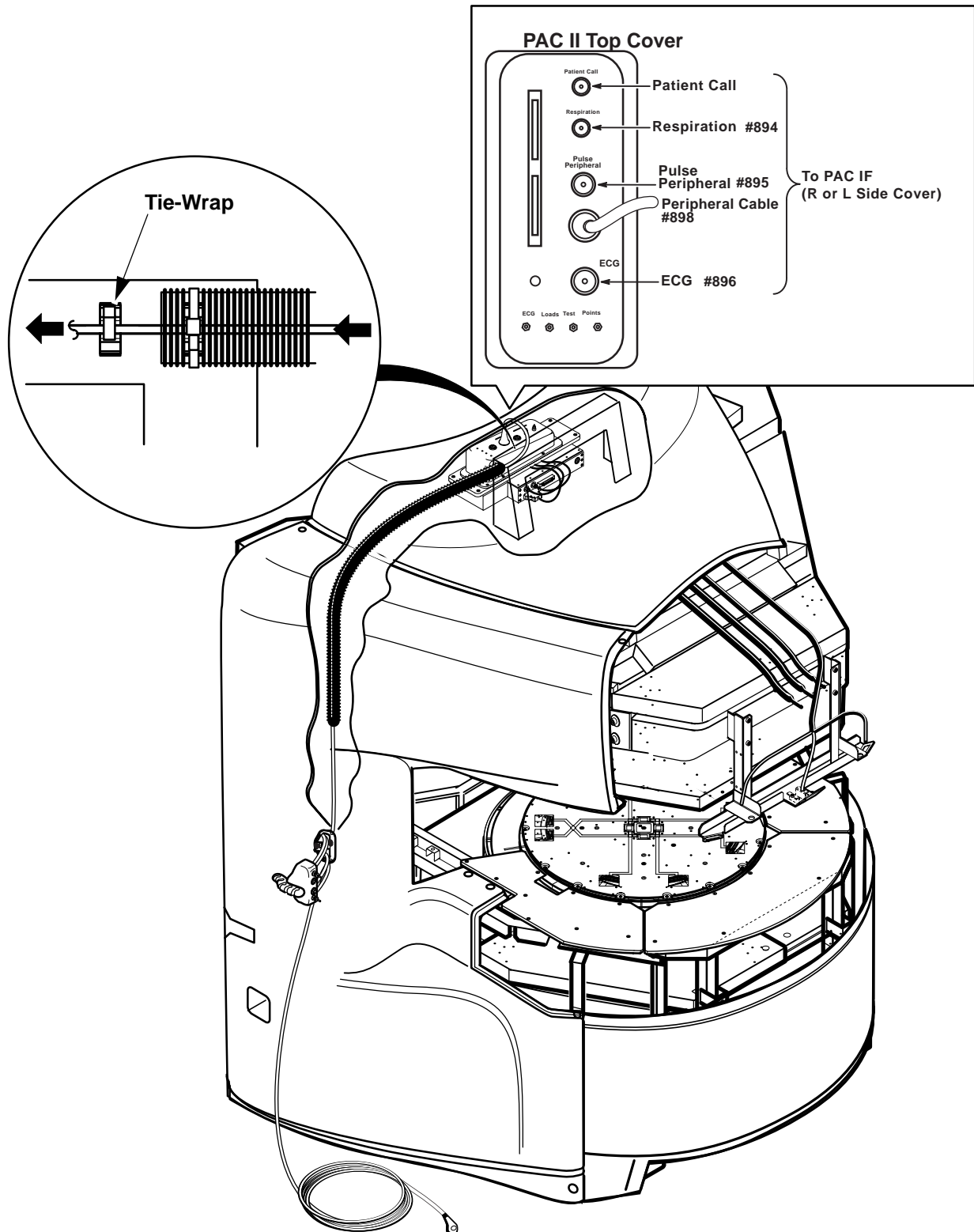

INSTALLING REMOTE PAC INTERFACE
ILLUSTRATION 13

Rev 4

5. Side Cover(Continued)

18. Set Grommet/PPG Cable to side cover, then direct cutting side of grommet to bottom side.
19. Use **M4** screw thru slot to lift and guide small end of Clamp over block inside housing.
20. Using screwdriver thru housing slot, tighten down the **M6** screws to lock housing in place.
21. Remove **M4** screw and save for use at later time since it would be required if Remote PAC Interface Assembly would need to be removed at any time in the future. OR Turn the M4 screw inward until there is clearance for sliding the PAC Hanger Bar in T5 into place.

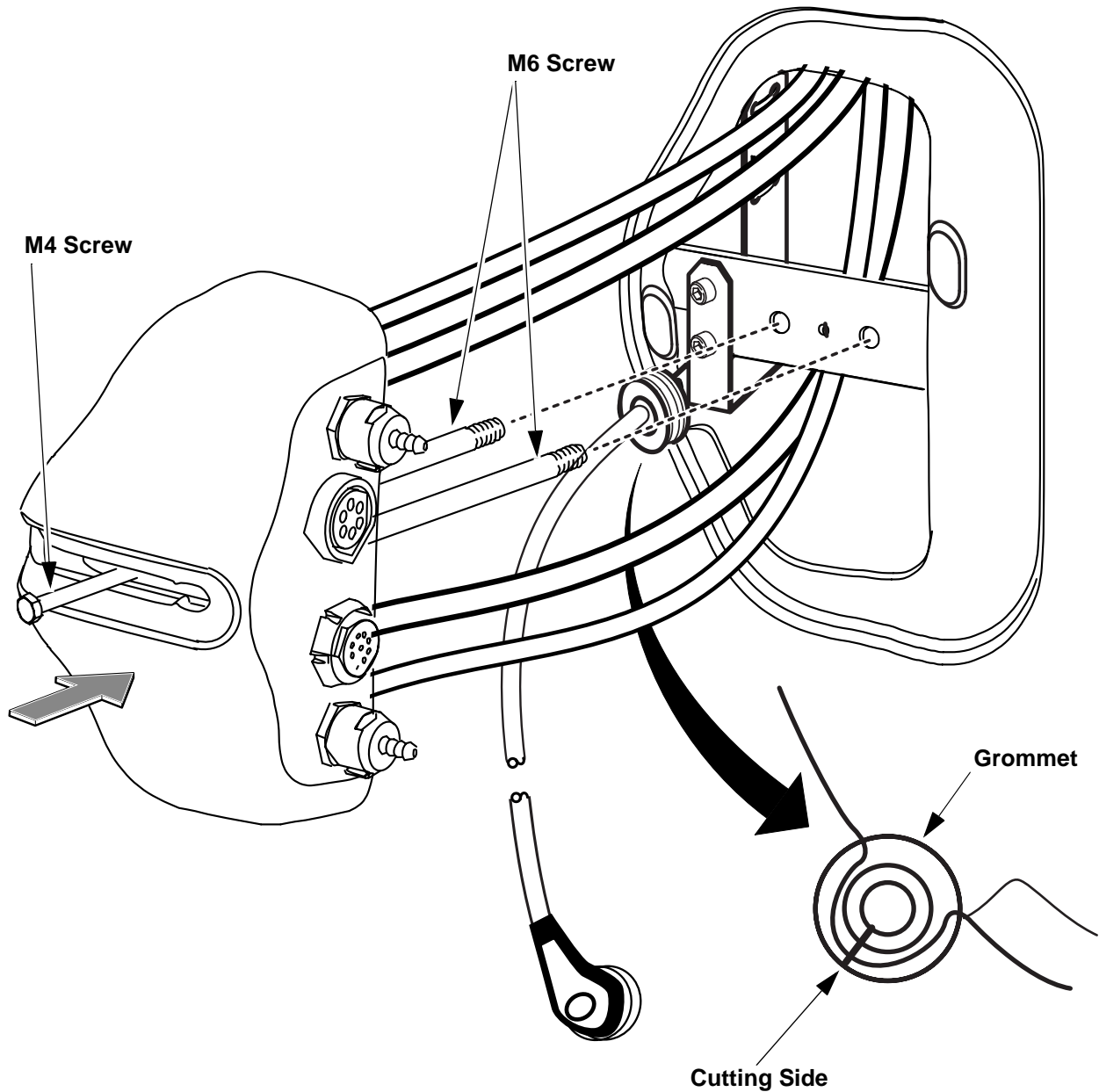

**INSTALLING REMOTE PAC INTERFACE
ILLUSTRATION 14**

Rev 4

5. Side Cover(Continued)

22.Fix Side Cover of PAC interface side with 8 screws.

NOTE:
PAC Remote Interface is L side layout in this illustration.

NOTE:
The screw number is
tightening order.

① ~ ⑦ Screws:U0438AA

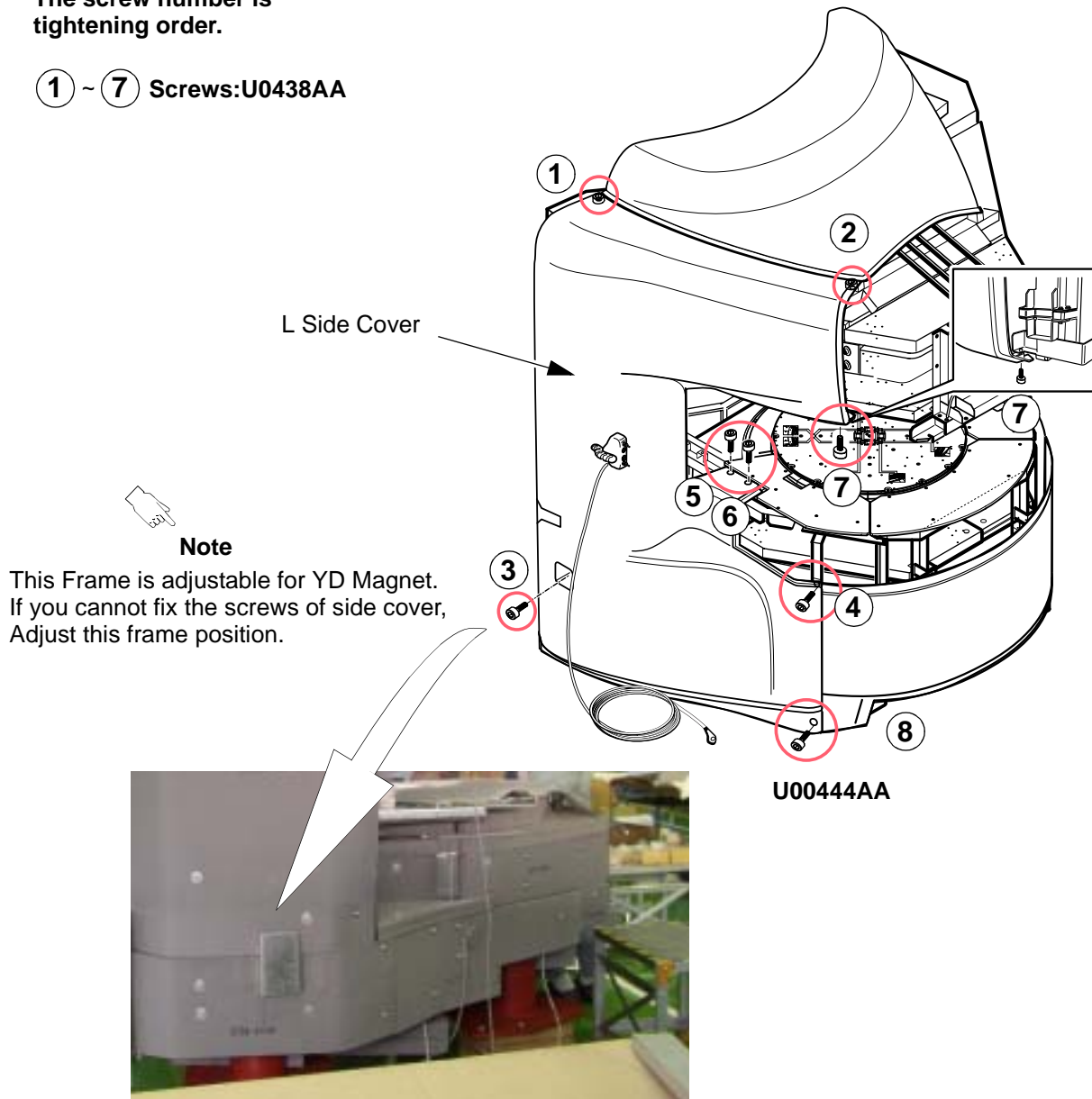

SIDE COVER INSTALLATION
ILLUSTRATION 15

Rev 4

5. Side Cover(Continued)

Another Side:

- 23. Install the dummy PAC Remote Interface for another side cover. (There is no cable connection)
- 24. Install the another side cover with 8 screws. (Refer to previous page.)

PAC Remote Interface Side:

- 25. Attach cables as indicated below.
- 26. Slide PAC Hanger Bar (2221023) into position.
- 27. Attach the three seals to side cover as illustration.

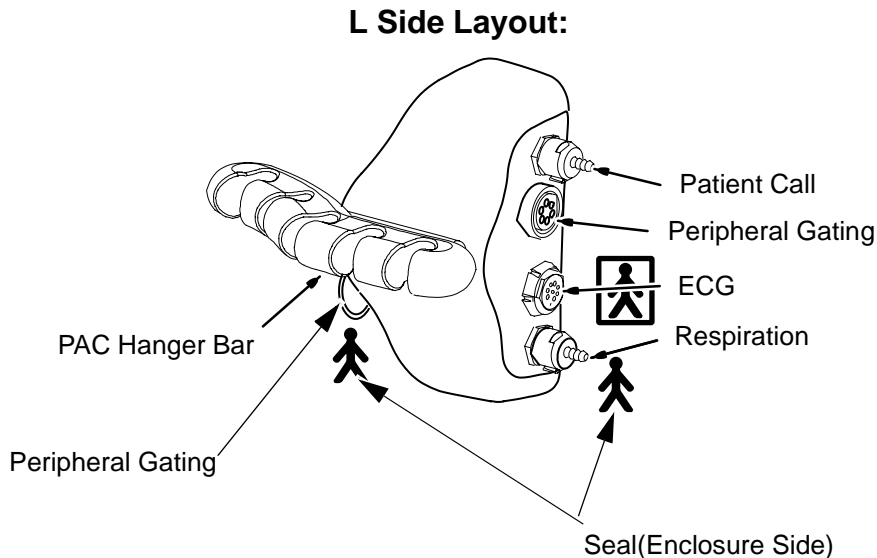
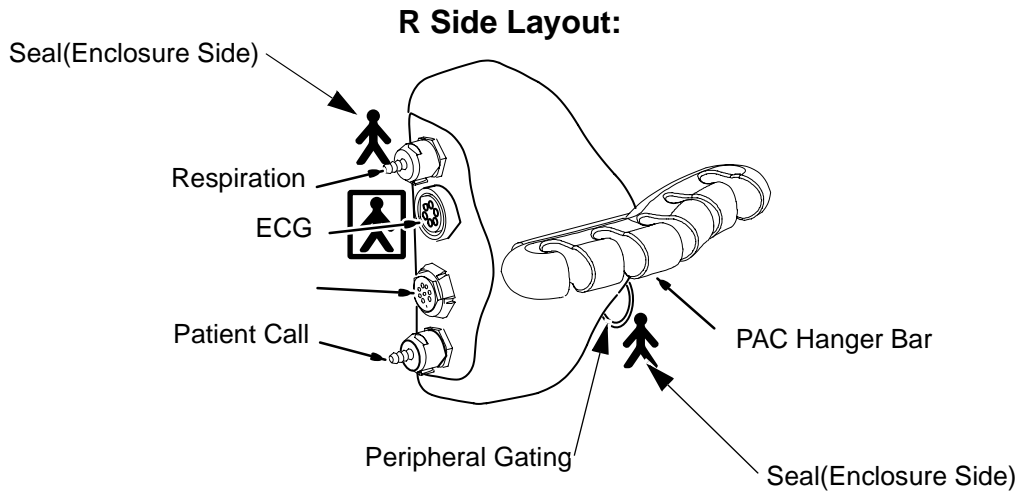

**INSTALL PAC HANGER BAR AND SEAL
ILLUSTRATION 16**

Rev 4

6. Front Cover

1. Before installing front cover, Install the following parts to front cover.
 - a. Install the GE Mark label aligning the lug and hole.
 - b. Route the R and L panel cables from side panel holes to center panel hole.
 - c. Connect side panel cable to L panel, and attach the L panel to front cover.
 - d. Connect side panel cable to R panel, and attach the R panel to front cover.

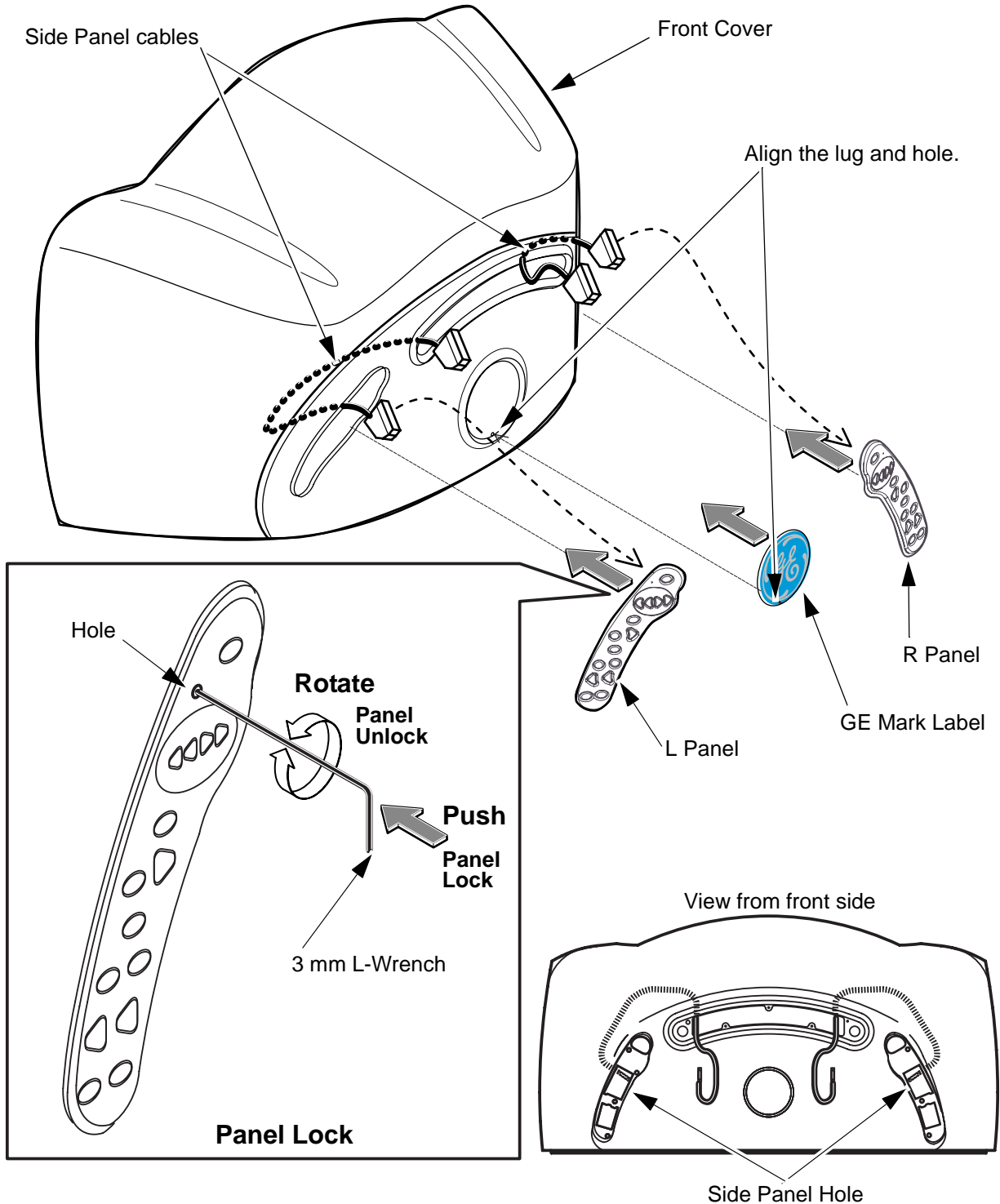

FRONT COVER INSTALLATION
ILLUSTRATION 17

Rev 4

6. Front Cover(Continued)

2. Route the MIC cable as illustration and put the MIC on deck plate.
3. Install Front Cover to the Magnet front side with 6screws(U0438AA x4,U0444AA x2) and 2washers(P9333DW).
4. Connect the all cables to J1~J5 connectors of center panel.
5. Attach the center panel to front cover.

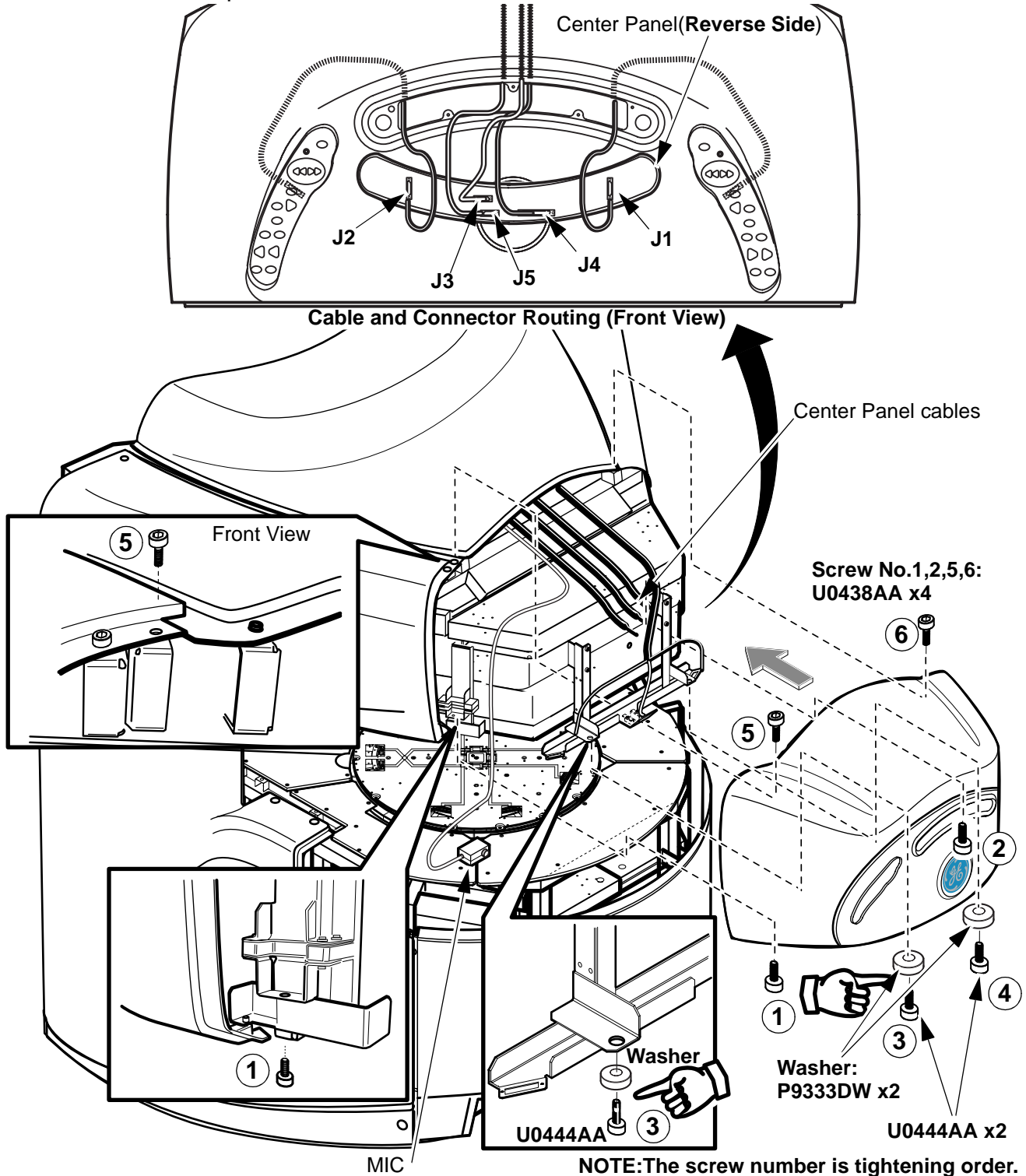

FRONT COVER INSTALLATION
ILLUSTRATION 18

Rev 4

7. Post Cover

1. Put R and L Post covers near post inside, connect pinch sensor connector of post cover to A1(L)/A2(R) label cables of run 1018 for each side.
2. Install R and L Post Covers to magnet frame with 6 screws(U0438AA) for each cover according to the installation order.

NOTE1:
Use 5mm-S Metric Allen Wrench to No.3 screw of L Post Cover.

NOTE2:
Install cover so that a clearance between covers becomes level.
Refer to Cover Clearance Adjustment of page 22.

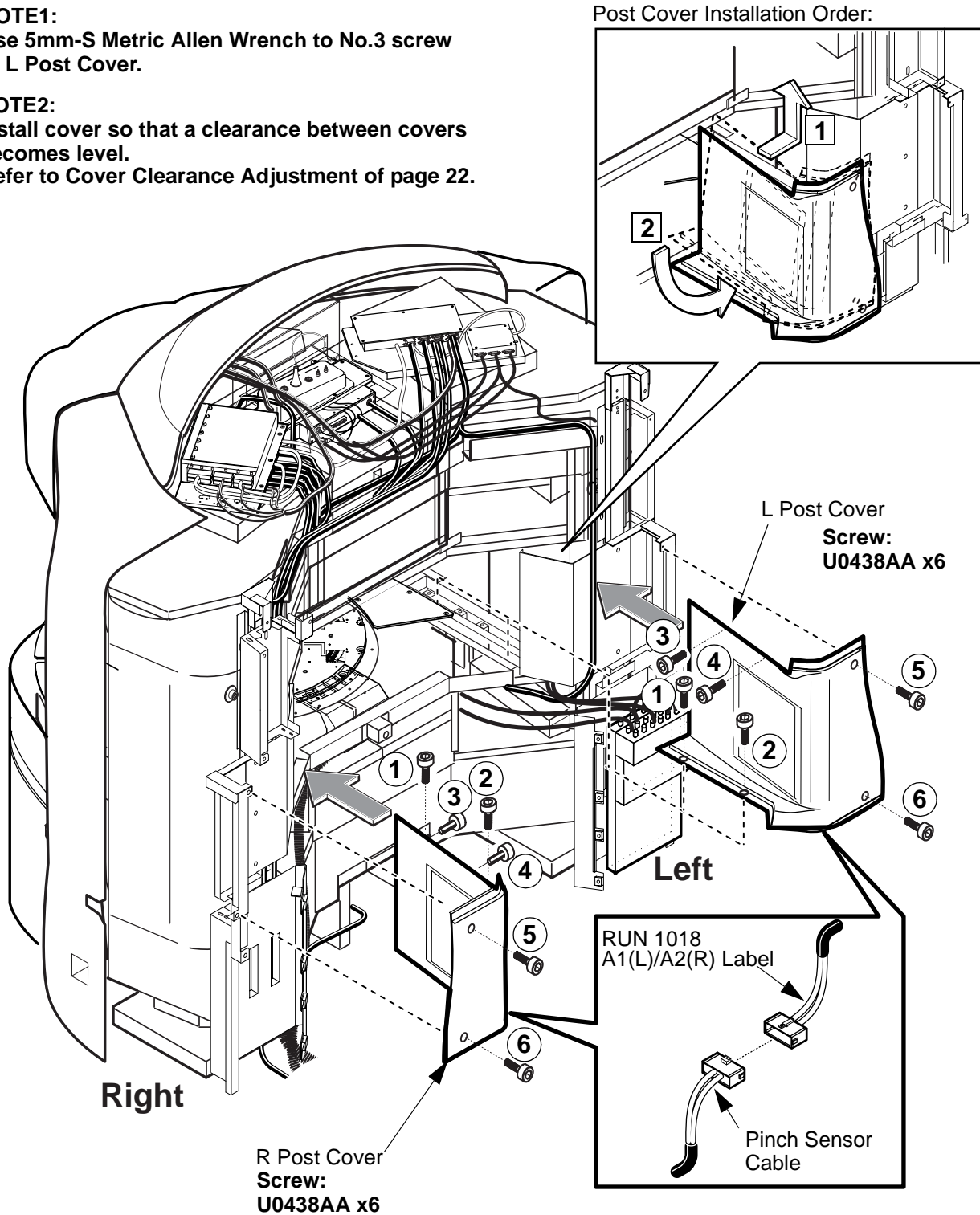

POST COVER INSTALLATION
ILLUSTRATION 19

Rev 4

8. Rear Deck Plate

1. Check that the all connection and routing of cables and units are normal.
2. Install Rear Deck Plates with screws(temporary tightening: U0444AA x 17 for YD Magnet. N9630YM x4 plus U0438AA x15 for YC Magnet) onto the rear lower frames. Tighten the 19 screws on rear deck plates.

L and R Rear Deck Plate:
No.4 and 6 Screws:M6L30
Other Screws:M6L12

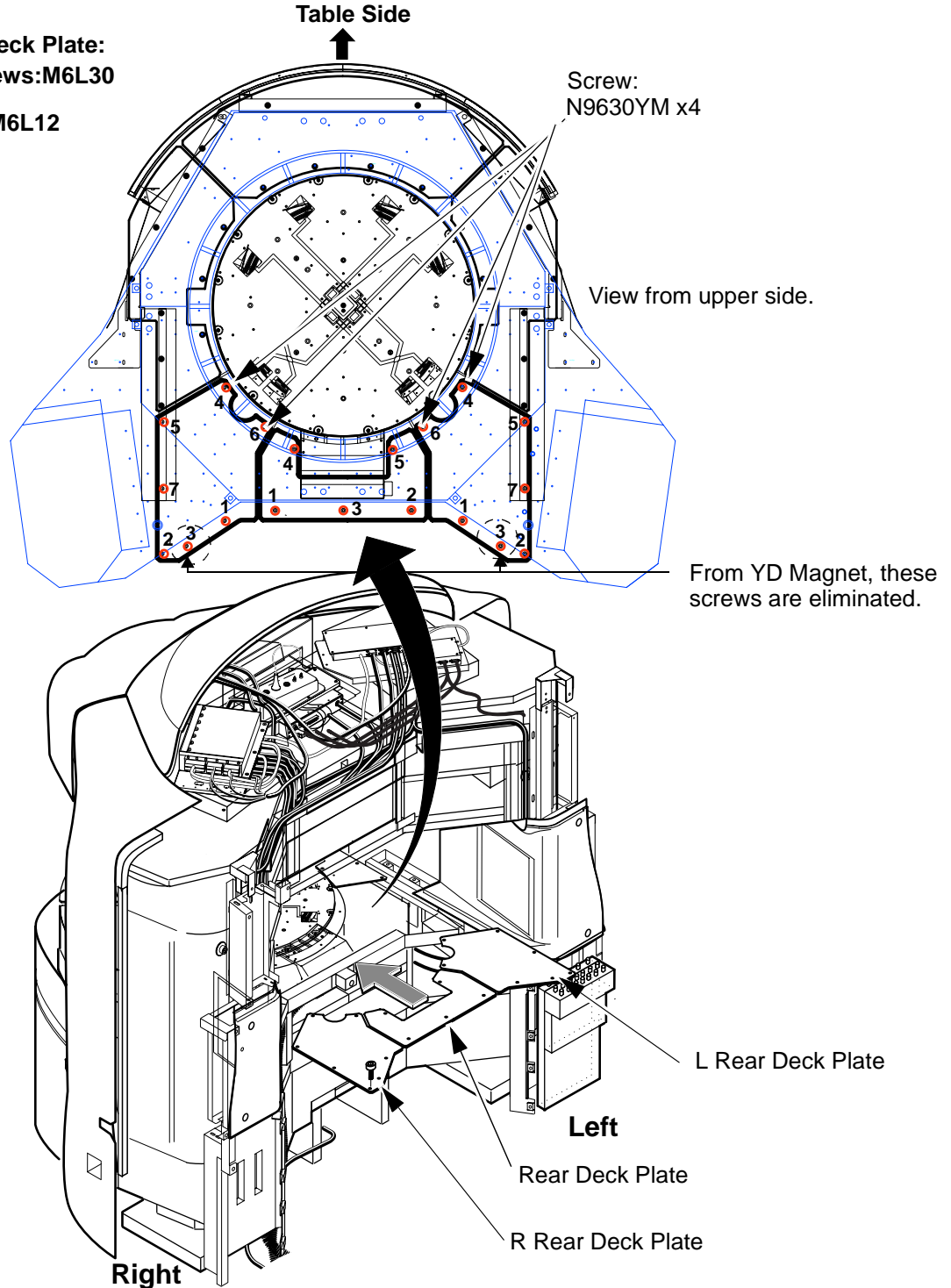

REAR DECK PLATE INSTALLATION
 ILLUSTRATION 20

Rev 4

9. Post Cover Clearance Adjustment

1. Install post cover so that a clearance between covers becomes level.

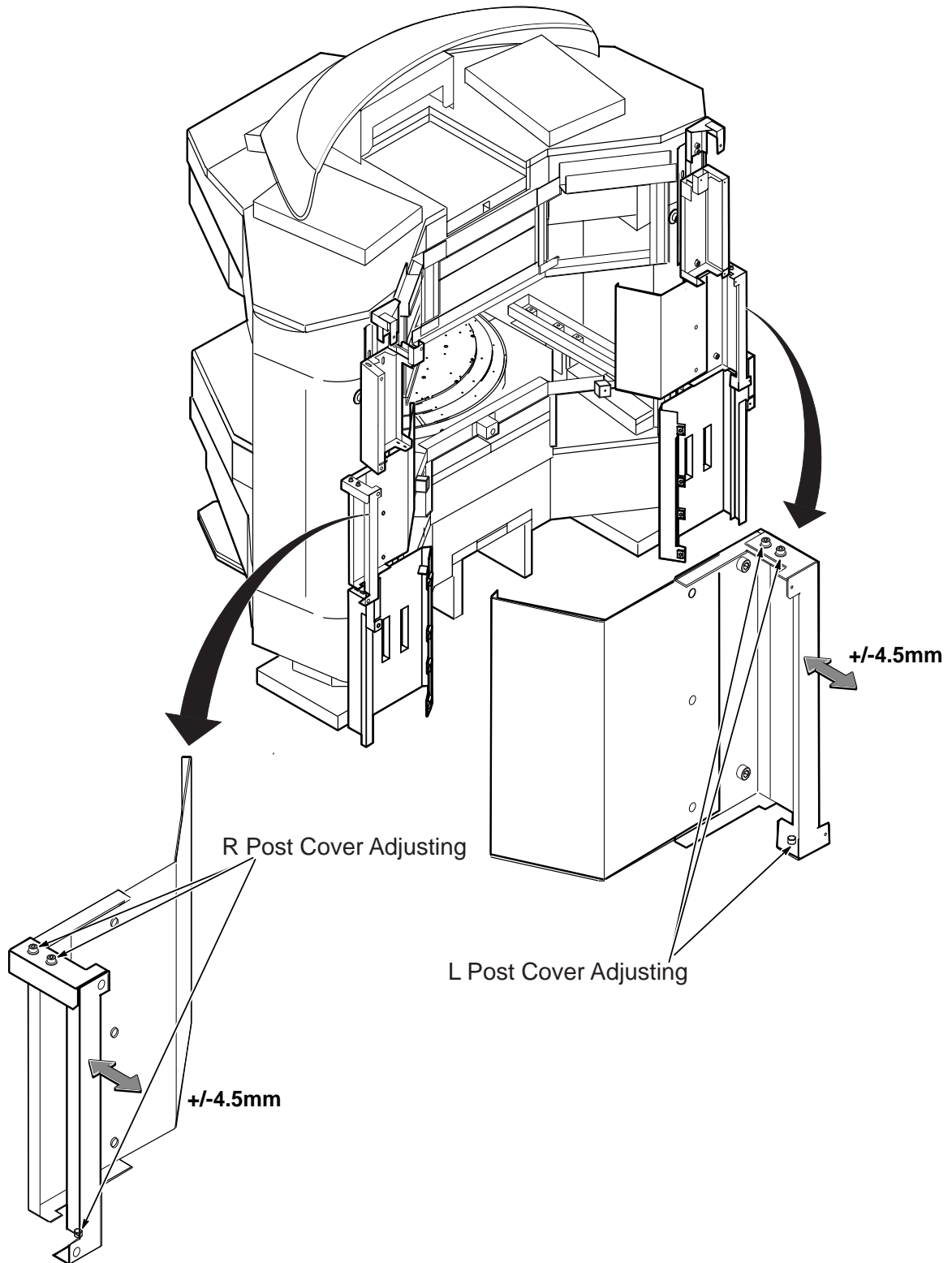

POST COVER CLEARANCE ADJUSTMENT
ILLUSTRATION 21

Revision History

Rev	Date	Author	Primary Reasons For Change
0	Mar 09, 2001	K.Tsumagari	Initial Release
1	May 19, 2001	K.Tsumagari	1. Top Cover installation is added 2. Misc Change
2	Oct 29, 2001	K.Tsumagari	Misc Change
3	Jan 08, 2002	K.Tsumagari	Page 19: Changed fixing screws of front cover.
4	Nov 26, 2002	Y.Masumo	Page 16: Added YD Information.