



GE Medical Systems

Technical Publications

Signa® Ovation Extra Large Body Coil Service Document

Copyright© 2002 by General Electric Co.

Operating Documentation

DAMAGE IN TRANSPORTATION

All packages should be closely examined at time of delivery. If damage is apparent, have notation "**damage in shipment**" written on **all** copies of the freight or express bill **before** delivery is accepted or "signed for" by a General Electric representative or a hospital receiving agent. Whether noted or concealed, damage **MUST** be reported to the carrier **immediately** upon discovery, or in any event, within **14** days after receipt, and the contents and containers held for inspection by the carrier. A transportation company will not pay a claim for damage if an inspection is not requested within this **14** day period.

Immediately complete a "Damage Loss Claim Form", available via MS Exchange Mail, after the damage is found.

MS Exchange Path:

Outlook/Public Folder/All Public Folders/Medical Systems/!Global Initiatives/Information Management/Forms/Common Forms/DAMAGE LOSS CLAIM FORM.

Send the completed form to the email address listed in the form.

For more information about the Transportation Claim Procedure, access the GE Medical Systems Intranet and enter the following URL address (case sensitive):

<ftp://3.87.40.2/globepro/qualsys/Docs/190016MF.PDF>

Rev. 11/15/2000

Language Policy For Service Documentation (Dir. 2128126)

W A R N I N G

- THIS SERVICE MANUAL IS AVAILABLE IN ENGLISH ONLY.
- IF A CUSTOMER'S SERVICE PROVIDER REQUIRES A LANGUAGE OTHER THAN ENGLISH, IT IS THE CUSTOMER'S RESPONSIBILITY TO PROVIDE TRANSLATION SERVICES.
- DO NOT ATTEMPT TO SERVICE THE EQUIPMENT UNLESS THIS SERVICE MANUAL HAS BEEN CONSULTED AND IS UNDERSTOOD.
- FAILURE TO HEED THIS WARNING MAY RESULT IN INJURY TO THE SERVICE PROVIDER, OPERATOR OR PATIENT FROM ELECTRIC SHOCK, MECHANICAL OR OTHER HAZARDS.

AVERTISSEMENT

- CE MANUEL DE MAINTENANCE N'EST DISPONIBLE QU'EN ANGLAIS.
- SI LE TECHNICIEN DU CLIENT A BESOIN DE CE MANUEL DANS UNE AUTRE LANGUE QUE L'ANGLAIS, C'EST AU CLIENT QU'IL INCOMBE DE LE FAIRE TRADUIRE.
- NE PAS TENTER D'INTERVENTION SUR LES ÉQUIPEMENTS TANT QUE LE MANUEL SERVICE N'A PAS ÉTÉ CONSULTÉ ET COMPRIS.
- LE NON-RESPECT DE CET AVERTISSEMENT PEUT ENTRAÎNER CHEZ LE TECHNICIEN, L'OPÉRATEUR OU LE PATIENT DES BLESSURES DUES À DES DANGERS ÉLECTRIQUES, MÉCANIQUES OU AUTRES.

WARNUNG

- DIESES KUNDENDIENST-HANDBUCH EXISTIERT NUR IN ENGLISCHER SPRACHE.
- FALLS EIN FREMDER KUNDENDIENST EINE ANDERE SPRACHE BENÖTIGT, IST ES AUFGABE DES KUNDEN FÜR EINE ENTSPRECHENDE ÜBERSETZUNG ZU SORGEN.
- VERSUCHEN SIE NICHT, DAS GERÄT ZU REPARIEREN, BEVOR DIESES KUNDENDIENST-HANDBUCH NICHT ZU RATE GEZOGEN UND VERSTANDEN WURDE.
- WIRD DIESE WARNUNG NICHT BEACHTET, SO KANN ES ZU VERLETZUNGEN DES KUNDENDIENSTTECHNIKERS, DES BEDIENERS ODER DES PATIENTEN DURCH ELEKTRISCHE SCHLÄGE, MECHANISCHE ODER SONSTIGE GEFAHREN KOMMEN.

AVISO

- ESTE MANUAL DE SERVICIO SÓLO EXISTE EN INGLÉS
- SI ALGÚN PROVEEDOR DE SERVICIOS AJENO A GEMS SOLICITA UN IDIOMA QUE NO SEA EL INGLÉS, ES RESPONSABILIDAD DEL CLIENTE OFRECER UN SERVICIO DE TRADUCCIÓN.
- NO SE DEBERÁ DAR SERVICIO TÉCNICO AL EQUIPO, SIN HABER CONSULTADO Y COMPRENDIDO ESTE MANUAL DE SERVICIO.
- LA NO OBSERVANCIA DEL PRESENTE AVISO PUEDE DAR LUGAR A QUE EL PROVEEDOR DE SERVICIOS, EL OPERADOR O EL PACIENTE SUFRAN LESIONES PROVOCADAS POR CAUSAS ELÉCTRICAS, MECÁNICAS O DE OTRA NATURALEZA.

ATENÇÃO

- ESTE MANUAL DE ASSISTÊNCIA TÉCNICA SÓ SE ENCONTRA DISPONÍVEL EM INGLÊS.
- SE QUALQUER OUTRO SERVIÇO DE ASSISTÊNCIA TÉCNICA, QUE NÃO A GEMS, SOLICITAR ESTES MANUAIS NOUTRO IDIOMA, É DA RESPONSABILIDADE DO CLIENTE FORNECER OS SERVIÇOS DE TRADUÇÃO.
- NÃO TENHA TENTADO REPARAR O EQUIPAMENTO SEM TER CONSULTADO E COMPREENDIDO ESTE MANUAL DE ASSISTÊNCIA TÉCNICA.
- O NÃO CUMPRIMENTO DESTA AVISO PODE POR EM PERIGO A SEGURANÇA DO TÉCNICO, OPERADOR OU PACIENTE DEVIDO A CHOQUES ELÉTRICOS, MECÂNICOS OU OUTROS.

AVVERTENZA

- IL PRESENTE MANUALE DI MANUTENZIONE È DISPONIBILE SOLTANTO IN INGLESE.
- SE UN ADDETTO ALLA MANUTENZIONE ESTERNO ALLA GEMS RICHIEDE IL MANUALE IN UNA LINGUA DIVERSA, IL CLIENTE È TENUTO A PROVVEDERE DIRETTAMENTE ALLA TRADUZIONE.
- SI PROCEDA ALLA MANUTENZIONE DELL'APPARECCHIATURA SOLO DOPO AVER CONSULTATO IL PRESENTE MANUALE ED AVERNE COMPRESO IL CONTENUTO.
- NON TENERE CONTO DELLA PRESENTE AVVERTENZA POTREBBE FAR COMPIERE OPERAZIONI DA CUI DERIVINO LESIONI ALL'ADDETTO ALLA MANUTENZIONE, ALL'UTILIZZATORE ED AL PAZIENTE PER FOLGORAZIONE ELETTRICA, PER URTI MECCANICI OD ALTRI RISCHI.

警告

- ・このサービスマニュアルは英語版しかありません。
- ・GEMS以外でサービスを担当される業者が英語以外の言語を要求される場合、翻訳作業はその業者の責任で行うものとさせていただきます。
- ・このサービスマニュアルを熟読し、理解せずに装置のサービスを行わないでください。
- ・この警告に従わない場合、サービスを担当される方、操作員あるいは患者さんが、感電や機械的又はその他の危険により負傷する可能性があります。

注意:

- 本维修手册仅存有英文本。
- 非 GEMS 公司的维修员要求非英文本的维修手册时，客户需自行负责翻译。
- 未详细阅读和完全了解本手册之前，不得进行维修。
- 忽略本注意事项会对维修员，操作员或病人造成触电，机械伤害或其他伤害。

TABLE OF CONTENTS

Damage in Transportation	2
Section 1 - Introduction	6
1-1 Prerequisite.....	6
1-2 Product Identification and Shipping List	7
1-3 Compatibility	7
1-4 Related Documentation	7
1-5 Environmental Requirements	8
1-6 Theory of Operation.....	8
Section 2 - Setup and Calibration	8
Section 2 - Setup and Calibration	9
2-1 Coil Installation	9
2-1-1 Special Install Notes	9
2-1-2 Configuration.....	9
2-2 Installation Functional Checks.....	9
2-3 Periodic Quality Assurance Check.....	9
Section 3 - Functional Checks	10
3-1 Scanner Verification.....	10
3-2 Coil Imaging Performance Verification	10
3-2-1 Tools Required.....	10
3-2-2 Explanation of Procedure	10
3-2-3 Signal Scan.....	11
3-3 External Cable Check.....	18
3-4 PIN Diodes Check	19
3-5 Mechanical Hardware Check.....	19
3-6 Troubleshooting Tips	19
Section 4 - Maintenance.....	20
4-1 Coil Care.....	20
4-2 Special Care Requirements.....	20
Section 5 - Replacement	21
5-1 Disassembly of Coil	21
5-2 External Cable Replacement.....	21
5-3 Mechanical Hardware Replacement	22
5-3-1 Body Flex Coil Locker Replacement	22
5-3-2 Troubleshooting for the Liquid Invasion.....	22
SECTION 6 - Renewal Parts.....	23
6-1 Field Replaceable Units.....	23
6-2 Other Replaceable Accessories	23
SECTION 7 - Appendix	23
SECTION 7 - Appendix	24
7-1 SNR Data Sheet	24
7-2 Schematic	25
7-3 Coil Configuration	25
7-3 Coil Configuration	26
Revision History	27

SECTION 1 - INTRODUCTION

1-1 Prerequisite

New Ceiling Cover is introduced for Extra Large Body Coil(Body XL Coil) from MFO3 M4 system. To use Extra Large Body Coil, new ceiling cover must be installed.



If the old ceiling cover remains in place without being replaced with the new one and Body XL Coil is used there, it may raise the possibility that Body XL Coil comes in contact with the "step" of the cover (the cover is not flat) and squeezes a patient, especially a large-build patient is at higher risk. The causes of this accident are as follows.

1. The "step" of the old ceiling cover is located deep inside the cover, which makes the "step" difficult to notice from outside the bore.
2. Since the "step" of the old ceiling cover is located deep inside the cover, when the cradle travels for patient positioning, Body XL Coil does not hit the "step". However, after patient positioning, while the cradle is traveling after [Move to Scan] button is pressed, Body XL Coil may come to the position to collide with the "step".

Notify customer not to use the Body XL Coil before replacing ceiling cover.

Identify the ceiling cover by the Microphone position.

Microphone is located at the center of the cover



Old Ceiling Cover

Microphone is located at the left of P-Light window.



New Ceiling Cover

If the ceiling cover is old type, order new ceiling cover.

ITEM	Part No.	Mcat#	DESCRIPTION	QTY
1	2360759	M20052BK	XL CLNG ASSY	1

Refer to Signa Ovation Service Methods to replace the ceiling cover.

1-2 Product Identification and Shipping List



SHIPPING LIST – TABLE 1-1

Description	GE Part#	Qty
Coil	2360905	1
Product Locator Card	2112666	1
Pad Assy	2361096	1
Body Strap XLW Assy	2174976	1
Phantom Positioner	2275522	1
Body Flex Seal	2277177	4
Operator's Guide	TBD	1
Service Manual	TBD	1
Customer Letter	TBD	1

1-3 Compatibility

This coil is compatible with the GE Signa Ovation 0.35T System

1-4 Related Documentation

Operator Manual

Signa Ovation Service Methods CD-ROM, 2283084

SECTION 2 - SETUP AND CALIBRATION

2-1 Coil Installation

2-1-1 Special Install Notes

1. Attach the warning label with local language on the English warning label.

2-1-2 Configuration

The system will automatically recognize the coil using the Coil ID feature. If the system does not recognize the coil, it is necessary to register coil config. Refer to the configuration information included in the Appendix and Service CD-ROM Manual.

2-2 Installation Functional Checks

1. From the Scan Desktop, start new scan by selecting [**New Pt**]; set **Patient ID** to “geservice” and **Patient Weight** to “111” pounds. Click [**Patient Position**] to open protocols window.
2. Plug the coil into the patient table and verify the coil indicator light turns green. A green light indicates the system hardware identifies the coil.
3. At the console, verify the Coil has been properly identified by the system: correct name in **Coil** field. Correct picture appears on the screen after MFO3 M4 System.
4. Perform system level Signal to Noise Check. Refer to Service Methods CD; System Level Procedures; Functional Checks; Signal to Noise Check.
5. Perform Section 3 - Coil Imaging Performance Verification.

2-3 Periodic Quality Assurance Check

On a periodic basis, such as during planned maintenance, perform the quality assurance checks as outlined below to ensure the coils is operating properly.

1. Check external cable for cracks or cuts.
2. Perform Section 3 - Coil Imaging Performance Verification and record data values in Data Sheet.

SECTION 3 - FUNCTIONAL CHECKS

3-1 Scanner Verification

Perform system level Signal to Noise Check. Refer to Service Methods CD; System Level Procedures; Functional Checks; Signal to Noise Check.

3-2 Coil Imaging Performance Verification

3-2-1 Tools Required

TOOLS REQUIRED – TABLE 3-2-1

Description	GE Part#	Qty
Phantom positioner	2275522	1
Short Loader Sphere Phantom (Note)	2135650-2	1

Note: Only the sphere Phantom from the body short loader is to be used.
Do NOT use the loader since the loader does not fit into the coil.

3-2-2 Explanation of Procedure

The image quality check uses the subtraction method to calculate SNR. The method requires two scans to create two phantom images. The signal value is measured from two images, and the noise value is measured from one subtracted image that is generated from two phantom images.

3-2-3 Signal Scan

1. From the Scan Desktop, start new scan by selecting [**New Pt**]; set **Patient ID** to “*geservice*” and **Patient Weight** to “111” pounds. Click [**Patient Position**] to open protocols window.
2. Remove all pads from the cradle. Then, set the Body XL Coil according to the Illustration.

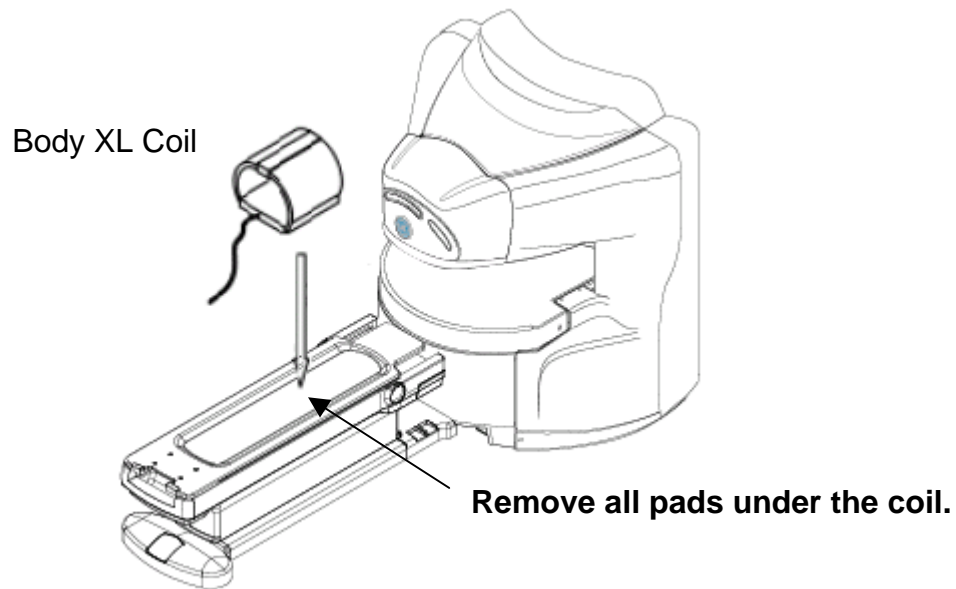

Note

If you find any wrinkles or pealed part in the seal, replace it with a new one.

COIL SETTING
ILLUSTRATION 3-1

3. Open the Body XL Coil, take away patient Pad if attached. Leave Base Pad.

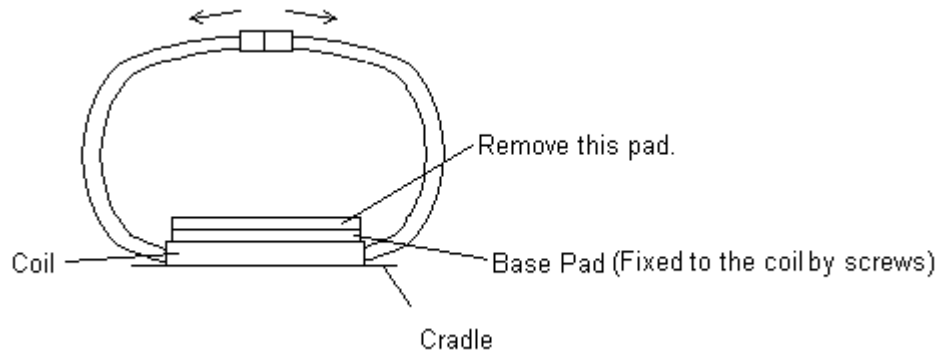
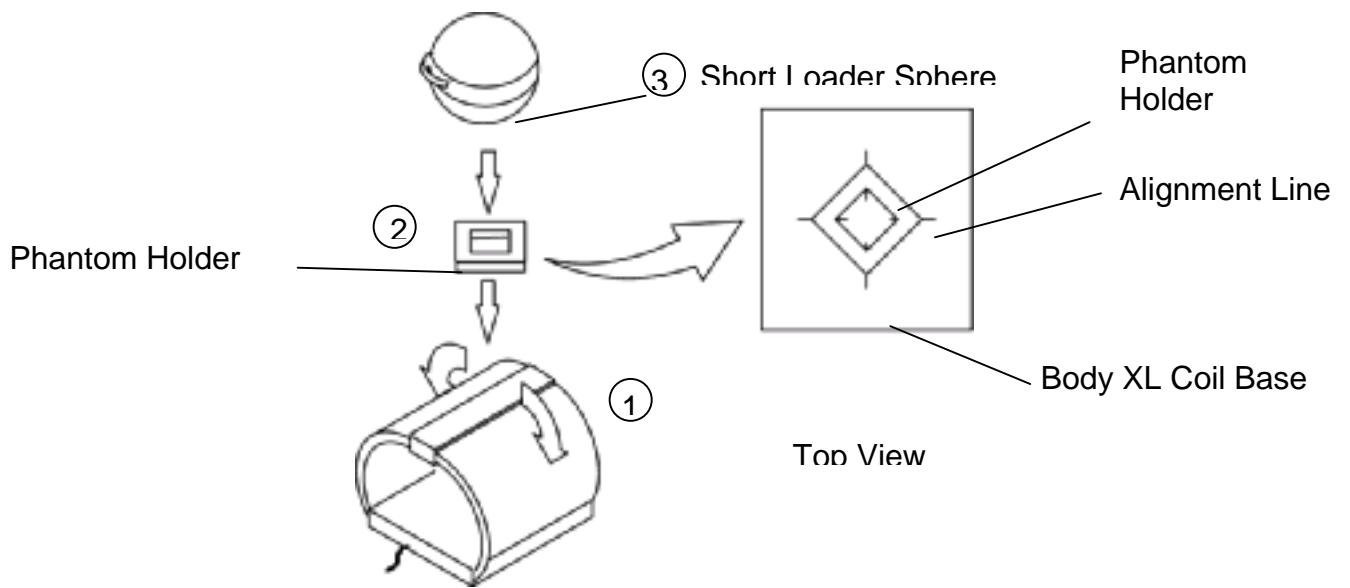

ILLUSTRATION 3-2

4. Set the phantom holder and Short Loader Sphere. Then, close the coil.

Note

Short Loader Sphere fits into the coil. Set the Phantom so that the handle comes side ways as shown in the figure. When closing the coil, align the connectors so the coil will snap together



PHANTOM SETTING
ILLUSTRATION 3-3

5. At the magnet, press “**Alignment Light**” button to turn on the light. Move the cradle to align the coil to the alignment lights. Press “**Landmark**” button to landmark the alignment.
6. Move the coil to scan position by pushing the “**Move to Scan**” button, ensuring cable does not get snagged.
7. At the console, verify the Coil has been properly identified by the system: correct name in **Coil** field. correct picture appears on the screen from MFO3 M4 system. If system does not recognize coil, refer to Section 2 - Setup and Calibration.
8. Set the protocols per the Signal section from Table 3-2-4: Signal and Noise Protocols.
9. Click [**Save Series**] to download the protocols, and then click [**Prepare to Scan**].
10. Run [**Auto Prescan**]. Record the R1, R2 and TG values on the SNR Data Sheet (found at the end of this manual).
11. Run [**Scan**] twice.

SIGNAL AND NOISE PROTOCOLS – TABLE 3-2-4

Protocol	Value
PATIENT/EXAM INFORMATION	
ID:	geservice
Name:	QA Scan
Patient Weight	111 lbs (50 kg)
PATIENT POSITION	
Patient Position:	Supine
Patient Entry:	Feet First
Coil:	Body XL
Series Description:	<i>leave blank</i>
IMAGE PARAMETERS	
Plane	Axial
Mode	2D
Pulse Seq:	SE
Imaging Option:	EDR
PSD Name:	<i>leave blank</i>
Protocol	<i>leave blank</i>
SCAN TIMING	
# of Echoes:	1
TE:	25
TR:	500
Bandwidth:	10.42
ADDITIONAL PARAMETER	
	None
ACQUISITION TIMMING	
Freq:	256
Phase:	256
NEX:	1
Phase FOV:	1.00
Freq DIR:	R/L
Auto Center Freq:	Peak
Autoshim:	On
Phase Correct:	Off
Contrast:	Off
# of Reps Before Pause:	0
SCANNING RANGE	
FOV:	35
Slice Thickness:	5
Spacing:	0
Start (S/I)	0.0
Start (L/R Center)	0.0
Start (P/A Center)	0.0
End (S/I Center)	0.0
# of Slice	1

3-2-4 Subtract Scan Images

1. Select Advantage Window Icon.



2. Click [**Add/Sub**] button.

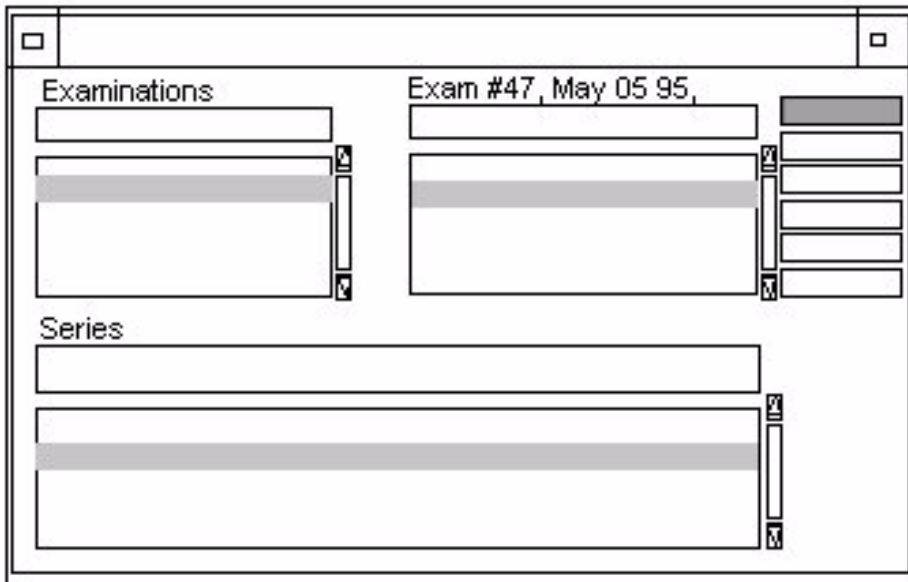

3. Subtract Image (1st Image - 2nd Image).

1. Click on "-".
2. Click on "Accept Negative
3. Select the Scan Image 1.
4. Click on "Select Set".(Left side)
5. Select the Scan Image 2.
6. Click "Select Set".(Right Side)
7. Click on "=".
8. Click "Quit".
9. The subtracted Image is saved as **Series 100****

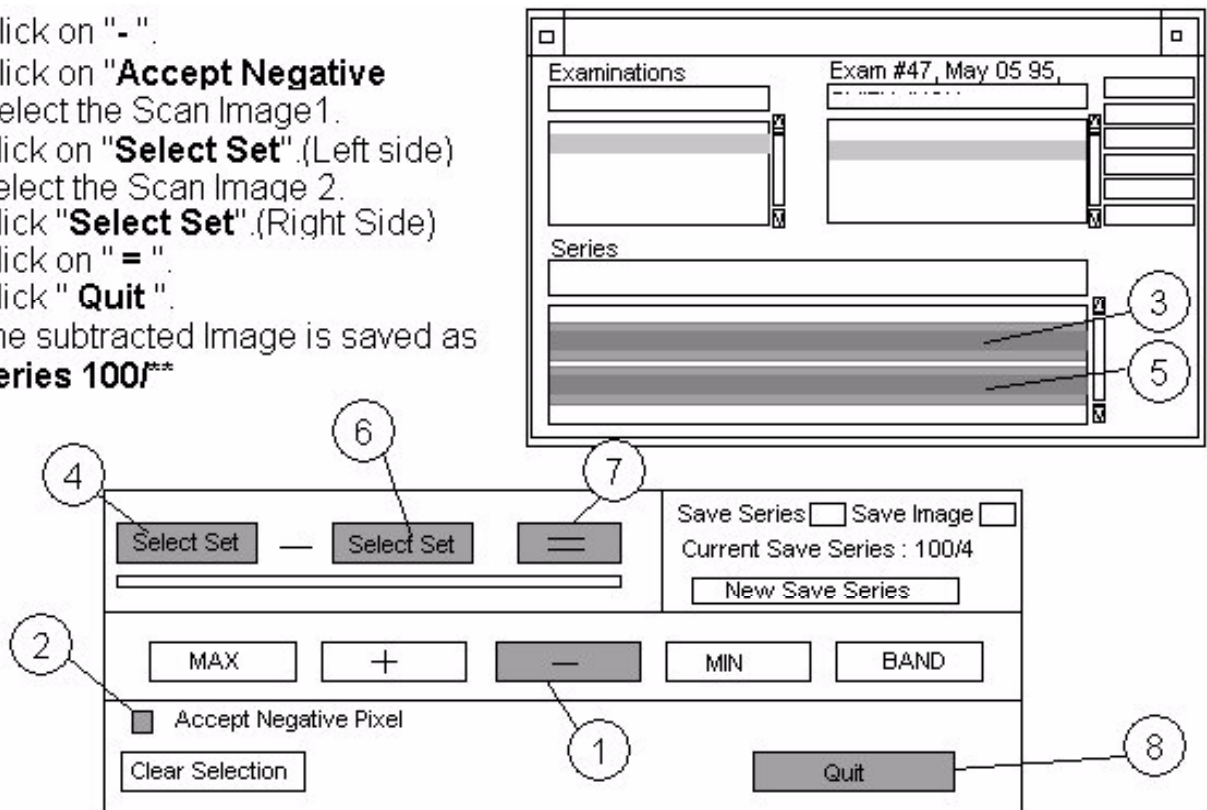

3-2-5 SNR Image Analysis

SNR Measurement

1. Display the Composite Signal Image.

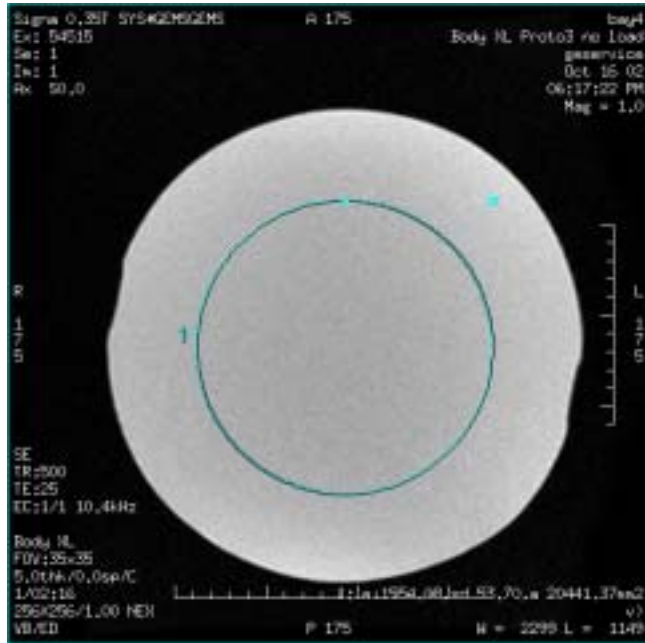

2. Set the Circular ROI Cursor in the middle of the Image. (ROI Area = 20,000mm²).
3. Record the Signal Mean in Data Sheet.
4. Display the Noise Image.

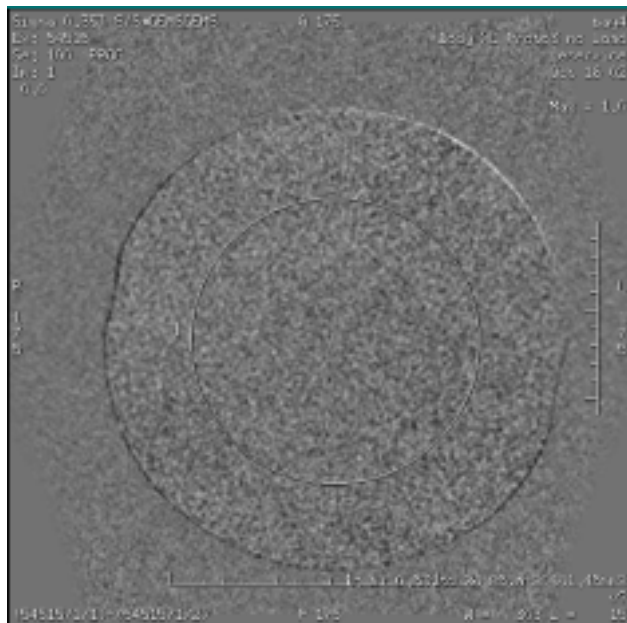

5. Copy the circular ROI Cursor from Signal Image and past it to the Noise Image.

6. Record the Noise SD in Sec 7-1 SNR Data Sheet.
7. Calculate the following formula and verify that the result value satisfies the specification. Record the SNR value in Sec 7-1 SNR Data Sheet.

$$\text{SNR} = \frac{\text{Signal Mean}}{\text{Noise SD}} \times \sqrt{2}$$

Note: The SNR calculation uses the **MEAN** of the signal image and **SD** of the noise image.

SNR Specification

The SNR measurements must be greater than or equal to the following specifications:

$$\text{SNR} \geq 76 \text{ (M3 tentative specification)}$$

3-3 External Cable Check

None

3-4 PIN Diodes Check

PIN DIODE EXPECTED READINGS – TABLE 3-4

Diode	Positive Lead	Negative Lead	Reading
Solid Active	A7, B7, C7, D7	A8, B8, C8, D8	400 - 450
Saddle Active	A9, B9, C9, D9	A8, B8, C8, D8	400 - 450

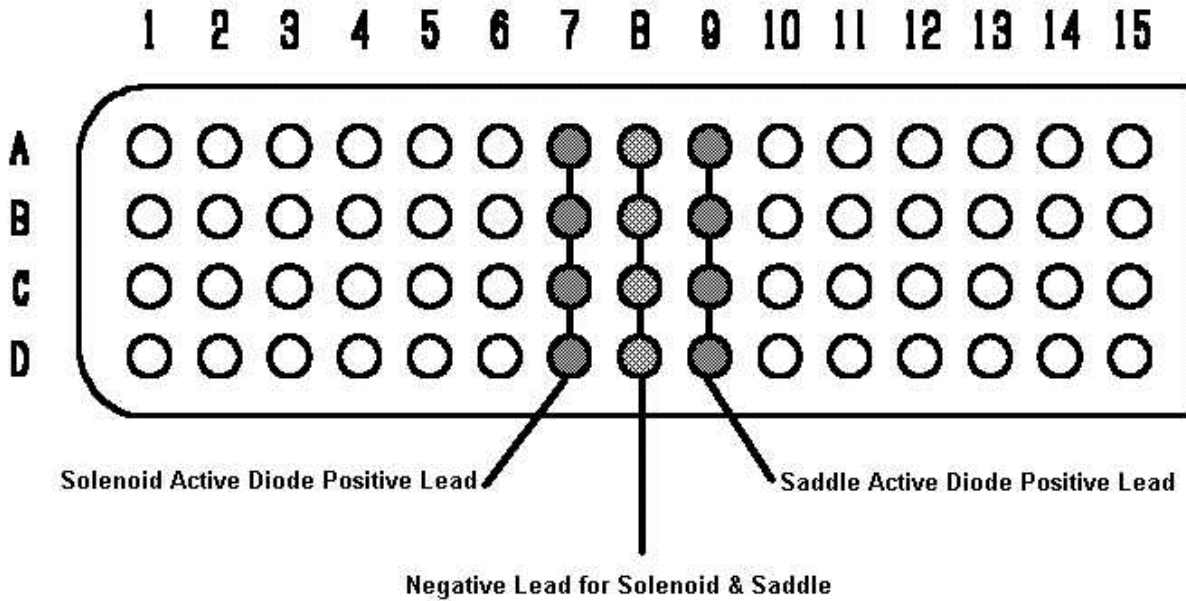

3-5 Mechanical Hardware Check

None

3-6 Troubleshooting Tips

See Section 5-3-3 and 5-3-4

SECTION 4 - MAINTENANCE

4-1 Coil Care



Detach coil connector from scanner before attempting to clean. Do not reattach after cleaning until coil has dried completely. Having the coil attached to the system during cleaning or when it is wet may result in electrical shock.



Do not spray or pour cleaning solution directly on coil. Do not submerge coil in solution. The coil contains sensitive electronics components that could be damaged by the solution.

4-2 Special Care Requirements

None

SECTION 5 - REPLACEMENT

Simple removals that are clearly obvious are not described here.

Unless otherwise noted, the steps for re-assembly are simply the reverse order of the steps described for disassembly.

5-1 Disassembly of Coil

None

5-2 External Cable Replacement

None

5-3 Mechanical Hardware Replacement

5-3-1 Body Flex Coil Locker Replacement

1. Remove two fixing screws. Then, remove Lock F2 assy.

Note

Wipe oil off from the fixing screws before reuse them since oil may damage the lock F2 Assy.

Note

It is not possible to replace the O-ring only. If O-ring is damaged, replace Lock F2 Assy.

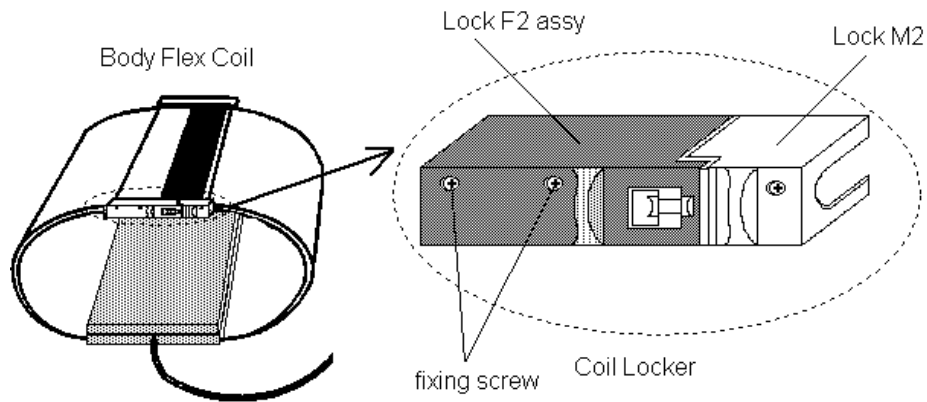

2. Remove two fixing screws. Then, remove Lock M2.
3. Install new Lock F2 assy and Lock M2 by the reverse order of removal.

5-3-2 Troubleshooting for the Liquid Invasion

Purpose:

Describes the troubleshooting method for the liquid invasion of the coil.

Solution:

Replace the coil

SECTION 6 - RENEWAL PARTS

6-1 Field Replaceable Units

FIELD REPLACEABLE UNITS LIST – TABLE 6-1

Description	GE Part#
Body Flex XL Coil	2360905
Lock M1 Assy	2148175
Lock M2 Assy	2148176
Lock F1 Assy	2169786-2
Lock F2 Assy	2169787-2
Phantom Holder	2275522
SV Item (screw)	2213833

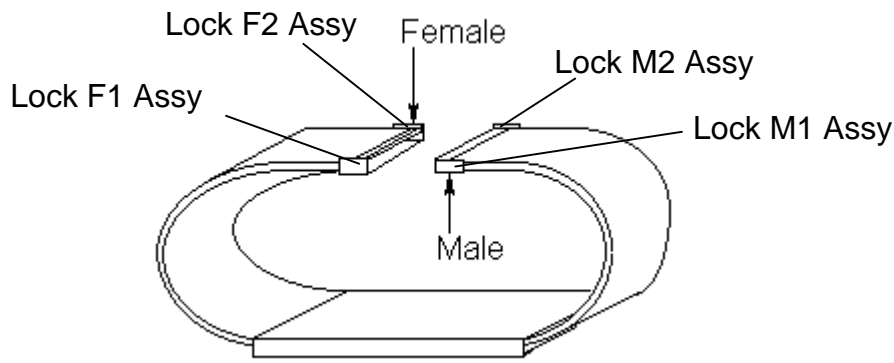

6-2 Other Replaceable Accessories

OTHER REPLACEABLE ACCESSORIES LIST – TABLE 6-2

Description	GE Part#	ECAT#
PAD ASSY	2361096	TBD
Body Strap XLW	2174976	TBD

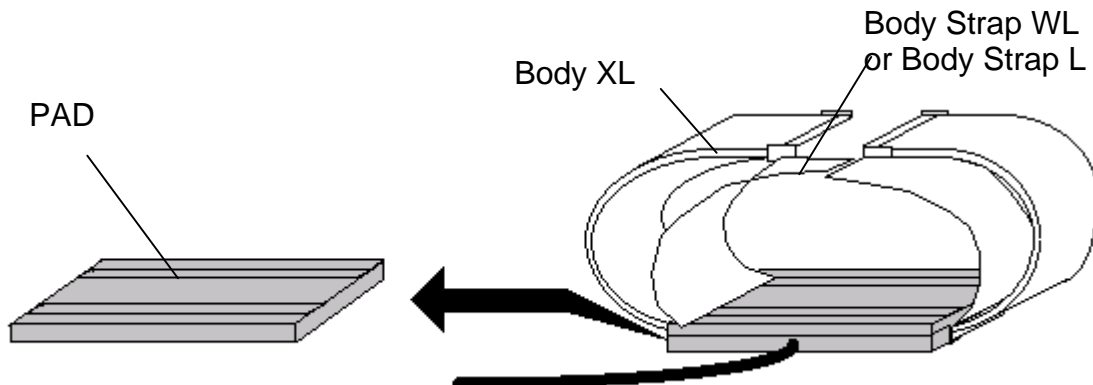

SECTION 7 - APPENDIX

7-1 SNR Data Sheet

Use the table provided below to record the calculated signal to noise ratio (SNR) data obtained from the Functional Checks section.

Date Tested	R1	R2	TG	Signal Mean1	Signal Mean 2	Noise Mean	SNR	Lower Spec.
								76 (for M3)
Comments								

Date Tested	R1	R2	TG	Signal Mean1	Signal Mean 2	Noise Mean	SNR	Lower Spec.
								76 (for M3)
Comments								

Date Tested	R1	R2	TG	Signal Mean1	Signal Mean 2	Noise Mean	SNR	Lower Spec.
								76 (for M3)
Comments								

Date Tested	R1	R2	TG	Signal Mean1	Signal Mean 2	Noise Mean	SNR	Lower Spec.
								76 (for M3)
Comments								

Date Tested	R1	R2	TG	Signal Mean1	Signal Mean 2	Noise Mean	SNR	Lower Spec.
								76 (for M3)
Comments								

7-2 Schematic

Saddle coil Schematics

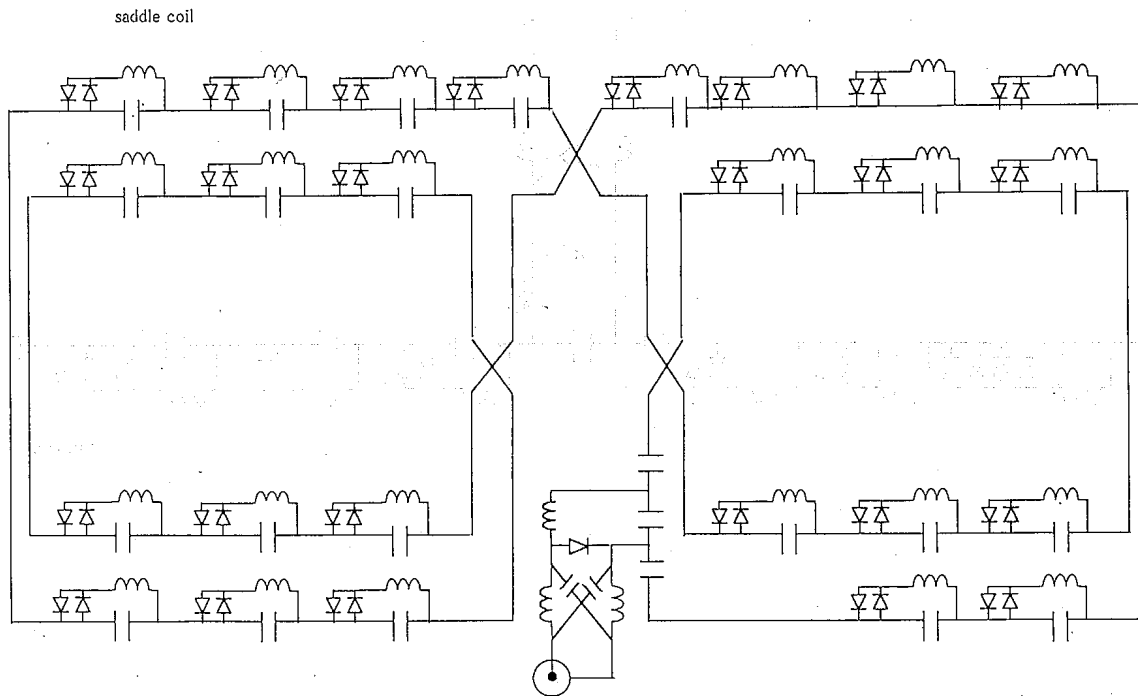

Solenoid coil Schematics

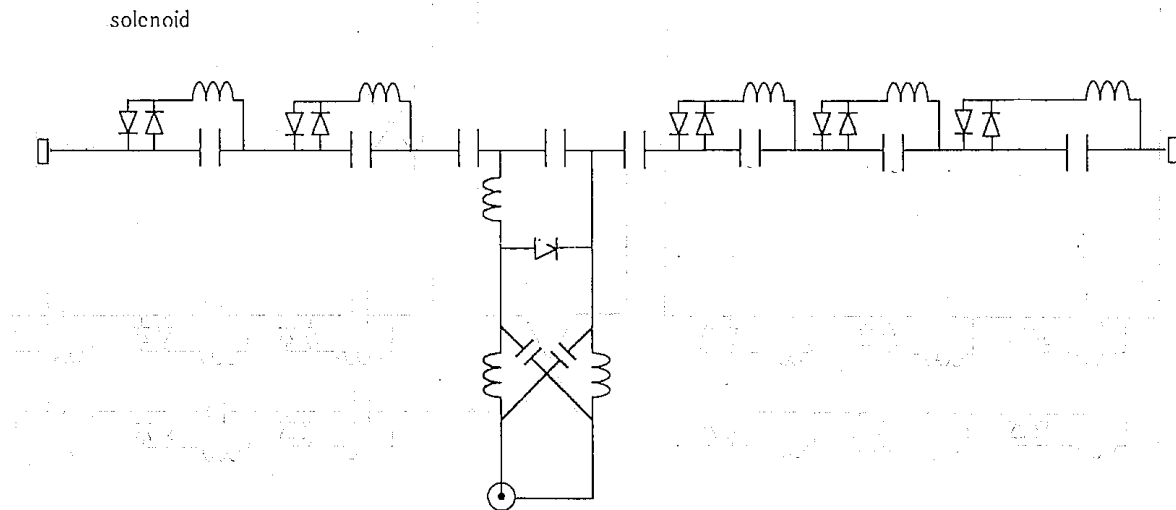

7-3 Coil Configuration

CoilConfig	CoilConfig in config manager	
coilName	Coil Name	Body XL
coilType	Coil Type	3
extremity	Extremity Coil	no
cableLoss	Cable Loss	1.0
coilLoss	CoilLoss	1.165
reconScale	Recon Scale Factor	2.7
linearQuad	Linear(0) vs. Quadrature(1)	1
multiCoil	Multiple Receiver Coil?	no
numRec	Number of Receivers	1
startRec	Starting Receiver ID	0
endRec	Ending Receiver ID	0
mcPortEnable	Multi-Coil Port Enable	0
mcErrorEnable	Multi-Coil Port Error Enable	0
xmitAtten	Additional transmit attenuation	0
numFastRec	Number of Fast Receivers	0
startFastRec	Starting Fast Receiver ID	4
endFastRec	Ending Fast Receiver ID	4
fastTGstartTA	Fast TG Start TA	90
fastTGstartRG	Fast TG Start RG	12
mcReconEnable	Multi Coil Recon Enable	0
autoshimRcvr	Phased Array T/R Coil for Autoshim	-1
headDefaultFreqDir	Head Default Freq Dir	0
scic_a (*)	SCIC++parameters for axial plane	0
scic_s (*)	SCIC++parameters for sagittal plane	0
scic_c (*)	SCIC++parameters for coronal plane	0
mcCoilSeparationDir (*)	Multi-coil Separation direction	0
coilCode	Coil Code	BODYFLXXL
mcChannelSel	Multi Coil Channel Selection	0
ATTN_Q	Attenuation-Q	3
ATTN_I	Attenuation-I	0
quadRotation	Select Quadrature Shifter	1
quadRcvCoil	quadRcvCoil	1
cfoption	cfoption	0
mcSwitchSel (*)	mcSwitchSelect	0

(*) These paramaters are added from MFO3 M3 software.

REVISION HISTORY

Rev	Date	Author	Primary Reason for Change
A	Oct 28 , 2002	Y. Masumo	Preliminary Rev A
B	Nov 20, 2002	Y. Masumo	P6: Updated Caution. P15 and P16: Added subtraction methods.
0	Dec 7, 2002	Y. Masumo	Initial Release