

# SERVICE MANUAL



USA Instruments, Inc.

Document 780039

Revision E

**GE Signa<sup>®</sup> Ovation<sup>™</sup>  
LEGEND 5000  
PHASED ARRAY KNEE AND FOOT COIL**

**GE Catalog Part Number: M20232BC**

**USAI Part Number: 160059**

*Copyright © 2001 by USA Instruments, Inc.*

## DAMAGE IN TRANSPORTATION

All packages should be closely examined at time of delivery. If damage is apparent, have notation "**damage in shipment**" written on **all** copies of the freight or express bill **before** delivery is accepted or "signed for" by a General Electric representative or a hospital receiving agent. Whether noted or concealed, damage **MUST** be reported to the carrier **immediately** upon discovery, or in any event, within **14** days after receipt, and the contents and containers held for inspection by the carrier. A transportation company will not pay a claim for damage if an inspection is not requested within this **14** day period.

**Immediately** complete a "Damage Loss Claim Form", available via MS Exchange Mail, after the damage is found.

MS Exchange Path:

Outlook/Public Folder/All Public Folders/Medical Systems/!Global Initiatives/Information Management/Forms/Common Forms/DAMAGE LOSS CLAIM FORM.

Send the completed form to the email address listed in the form.

For more information about the Transportation Claim Procedure, access the GE Medical Systems Intranet and enter the following URL address (case sensitive):

<ftp://3.87.40.2/globepro/qualsys/Docs/190016MF.PDF>

## Language Policy For Service Documentation (Dir. 2128126)

### WARNING

- This service manual is available in English only.
- If a customer's service provider requires a language other than English, it is the customer's responsibility to provide translation services.
- Do not attempt to service the equipment unless this service manual has been consulted and is understood.
- Failure to heed this warning may result in injury to the service provider, operator or patient from electric shock, mechanical or other hazards.

### AVERTISSEMENT

- Ce manuel de maintenance n'est disponible qu'en anglais.
- Si le technicien du client a besoin de ce manuel dans une autre langue que l'anglais, c'est au client qu'il incombe de le faire traduire.
- Ne pas tenter d'intervention sur les équipements tant que le manuel service n'a pas été consulté et compris.
- Le non-respect de cet avertissement peut entraîner chez le technicien, l'opérateur ou le patient des blessures dues à des dangers électriques, mécaniques ou autres.

### WARNUNG

- Dieses kundendienst-handbuch existiert nur in englischer sprache.
- Falls ein fremder kundendienst eine andere sprache benötigt, ist es aufgabe des kunden für eine entsprechende übersetzung zu sorgen.
- Versuchen sie nicht, das gerät zu reparieren, bevor dieses kundendienst-handbuch nicht zu rate gezogen und verstanden wurde.
- Wird diese warnung nicht beachtet, so kann es zu verletzungen des kundendiensttechnikern, des bedieners oder des patienten durch elektrische schläge, mechanische oder sonstige gefahren kommen.

### AVISO

- Este manual de servicio sólo existe en inglés.
- Si algún proveedor de servicios ajeno a gems solicita un idioma que no sea el inglés, es responsabilidad del cliente ofrecer un servicio de traducción.
- No se deberá dar servicio técnico al equipo, sin haber consultado y comprendido este manual de servicio.
- La no observancia del presente aviso puede dar lugar a que el proveedor de servicios, el operador o el paciente sufran lesiones provocadas por causas eléctricas, mecánicas o de otra naturaleza.

### ATENÇÃO

- Este manual de assistência técnica só se encontra disponível em inglês.
- Se qualquer outro serviço de assistência técnica, que não a gems, solicitar estes manuais noutra idioma, é da responsabilidade do cliente fornecer os serviços de tradução.
- Não tente reparar o equipamento sem ter consultado e compreendido este manual de assistência técnica.
- Não cumprimento deste aviso pode por em perigo a segurança do técnico, operador ou paciente devido a' choques elétricos, mecânicos ou outros.

**AVVERTENZA**

- Il presente manuale di manutenzione è disponibile soltanto in inglese.
- Se un addetto alla manutenzione esterno alla gems richiede il manuale in una lingua diversa, il cliente è tenuto a provvedere direttamente alla traduzione.
- Si proceda alla manutenzione dell'apparecchiatura solo dopo aver consultato il presente manuale ed averne compreso il contenuto.
- Non tenere conto della presente avvertenza potrebbe far compiere operazioni da cui derivino lesioni all'addetto alla manutenzione, all'utilizzatore ed al paziente per folgorazione elettrica, per urti meccanici od altri rischi.

**警告**

- ・このサービスマニュアルは英語版しかありません。
- ・GEMS以外でサービスを担当される業者が英語以外の言語を要求される場合、翻訳作業はその業者の責任で行うのとさせていただきます。
- ・このサービスマニュアルを熟読し、理解せずに装置のサービスを行わないでください。
- ・この警告に従わない場合、サービスを担当される方、操作員あるいは患者さんが、感電や機械的又はその他の危険により負傷する可能性があります。

**注意:**

- 本维修手册仅存有英文本。
- 非 GEMS 公司的维修员要求非英文本的维修手册时，客户需自行负责翻译。
- 未详细阅读和完全了解本手册之前，不得进行维修。
- 忽略本注意事项会对维修员，操作员或病人造成触电，机械伤害或其他伤害。

## TABLE OF CONTENTS

<b>Damage in Transportation .....</b>	<b>2</b>
<b>Section 1 – Introduction .....</b>	<b>6</b>
1-1 Product Identification and Shipping List.....	6
1-2 Compatibility.....	7
1-3 Related Documentation.....	7
1-4 Environmental Requirements.....	7
1-5 Theory of Operation .....	7
<b>Section 2 – Setup and Calibration.....</b>	<b>10</b>
2-1 Coil Installation.....	10
2-1-1 Special Install Notes .....	10
2-1-2 Configuration.....	10
2-2 Installation Functional Checks .....	10
2-3 Periodic Quality Assurance Check.....	10
<b>Section 3 – Functional Checks .....</b>	<b>11</b>
3-1 Scanner Verification .....	11
3-2 Coil Imaging Performance Verification.....	11
3-2-1 Tools Required.....	11
3-2-2 Explanation of Procedure .....	11
3-2-3 Scan Setup .....	11
3-2-4 Phantom Scan .....	14
3-2-5 Create Subtraction Images.....	14
3-2-6 Setting the Cursor.....	15
3-2-7 SNR Image Analysis .....	16
3-3 External Cable Check .....	19
3-4 PIN Diodes Check.....	19
3-5 Mechanical Hardware Check .....	19
3-6 Troubleshooting Tips.....	20
<b>Section 4 – Maintenance .....</b>	<b>23</b>
4-1 Coil Care .....	23
4-2 Special Care Requirements .....	23
<b>Section 5 – Replacement.....</b>	<b>24</b>
5-1 External Cable Replacement .....	24
5-2 Repairing the Latch Mechanism.....	25
<b>Section 6 – Renewal Parts .....</b>	<b>26</b>
6-1 Field Replaceable Units .....	26
6-2 Other Replaceable Accessories.....	26
<b>Section 7 – Appendix.....</b>	<b>27</b>
7-1 SNR Data Sheet.....	27
7-2 Schematic.....	28
7-3 Coil Configuration.....	29
<b>Revision History.....</b>	<b>30</b>

**SECTION 1 – INTRODUCTION**

**1-1 Product Identification and Shipping List**

To identify the Legend 5000 Phased Array Knee and Foot Coil, refer to the coil labels located underneath the coil (as shown in *Figure 1*).

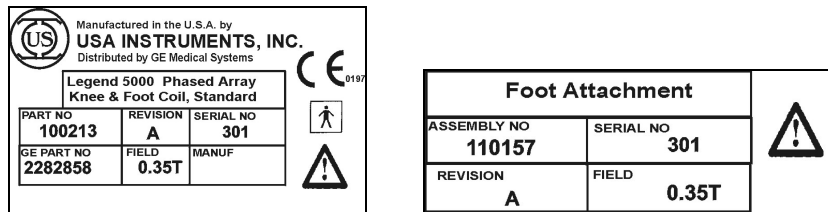

*Figure 1: Coil labels.*

*Figure 2* shows a picture of the Legend 5000 Phased Array Knee and Foot Coil.



*Figure 2: The Phased Array Knee and Foot Coil.*

**SHIPPING LIST – TABLE 1-1**

Box #	Part Name	GE Part #	USAI Part #	Qty
1	Knee Coil (Standard) and Foot Attachment	2282858	100213	1
1	Patient Comfort Pad, Knee Coil	E8801TA	150128	1
1	Transition Pad	E8801TB	150163	1
1	Patient Comfort Pad, Foot Attachment, Upper	2284661	150250	1
1	Patient Comfort Pad, Foot Attachment, Lower	E8801TE	150155	1
2	Phantom, Knee Coil (Standard)	2264742-8	150210	1
2	Phantom, Foot Attachment	2264742-4	150133	1
2	Phantom Positioner, Knee Coil (Standard)	2284544	150134	1
1	Operator's Guide	2282848	770059	1
1	Service Manual	2284548	780039	1

## 1-2 Compatibility

This coil is compatible with the GE Signa<sup>®</sup> Ovation<sup>™</sup> 0.35T system.

## 1-3 Related Documentation

Operator's Guide, GE Part Number 2282848.

GE MR Service Methods CD, 2283084.

## 1-4 Environmental Requirements

### Storage

Coil should be stored in the scanner room.

### Dimensions

Knee Coil (Standard): 26.67 cm x 26.18 cm x 21.10 cm (10.5" x 10.31" x 8.31")

Foot Attachment: 37.62 cm x 27.56 cm x 20.23 cm (14.81" x 10.85" x 7.96")

### Weight

Knee Coil (Standard): 2.89 kg (6.38 lbs.)

Foot Attachment: 1.814 kg (4 lbs.)

## 1-5 Theory of Operation

The physical layout of the Legend 5000 Phased Array Knee and Foot Coil is shown in *Figure 3* and the block diagram of the Standard Knee Coil is shown in *Figure 4*. The coil is designed for imaging the knee and foot anatomies.

The sensitive region of the knee coil covers approximately 16cm to 18cm in the head to foot direction, while the foot coil covers approximately 19cm in the heel to toe direction. The knee coil consists of a saddle and loop coil arranged orthogonally and can be used as a quadrature or phased array (two channel) coil. The foot coil consists of a single saddle coil and is electrically connected to the knee coil to form a three-channel knee and foot coil.

The coil is a receive-only coil as indicated in the schematic shown in the Appendix. The coil is actively decoupled from the RF transmit coil during transmit by means of a RF choking circuit. The choking circuit elements are switched on and off by the switching small-signal diodes and by pin diodes. During body coil transmission, the switching small-signal diodes are turned on by the induced RF voltage in the chokes, coupled from the transmit field (passive decoupling). Each small signal diode is turned on when the induced RF voltage reaches about 0.5 volt. The pin diodes are turned on, as shorted circuits, with a forward bias DC source (active decoupling) provided by the system. When the switching diodes are turned on, each of these RF choking elements becomes very high in impedance (above 50 kilo-ohm). These high impedance elements in the coil circuit segregate the coil circuitry into several isolated electrical segments, preventing any current flow in the coil circuit.

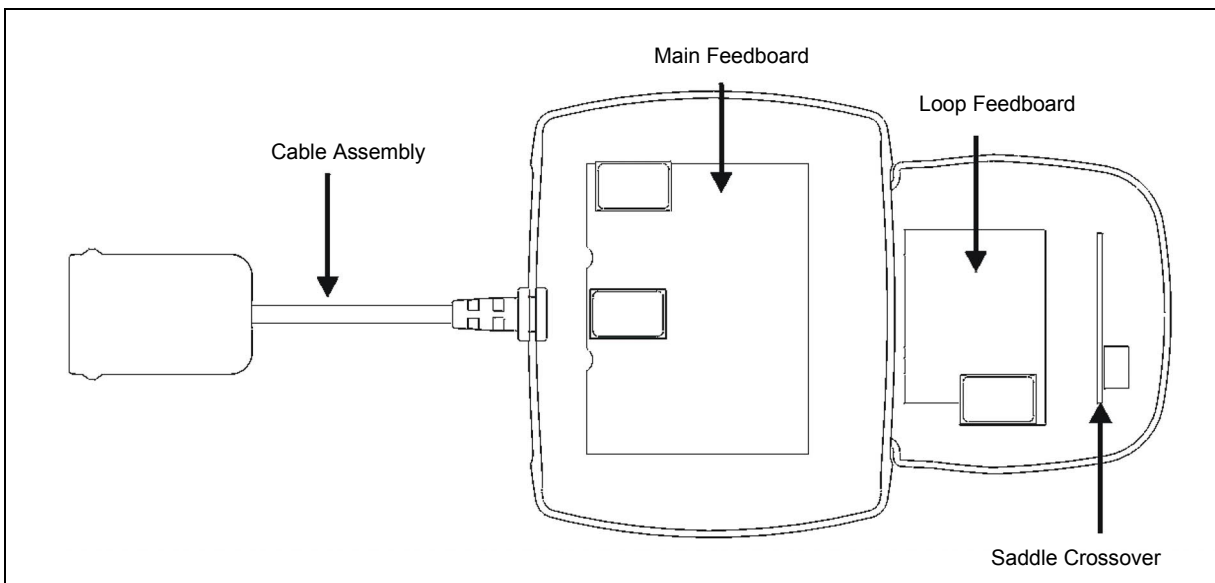

Figure 3: Coil physical layout.

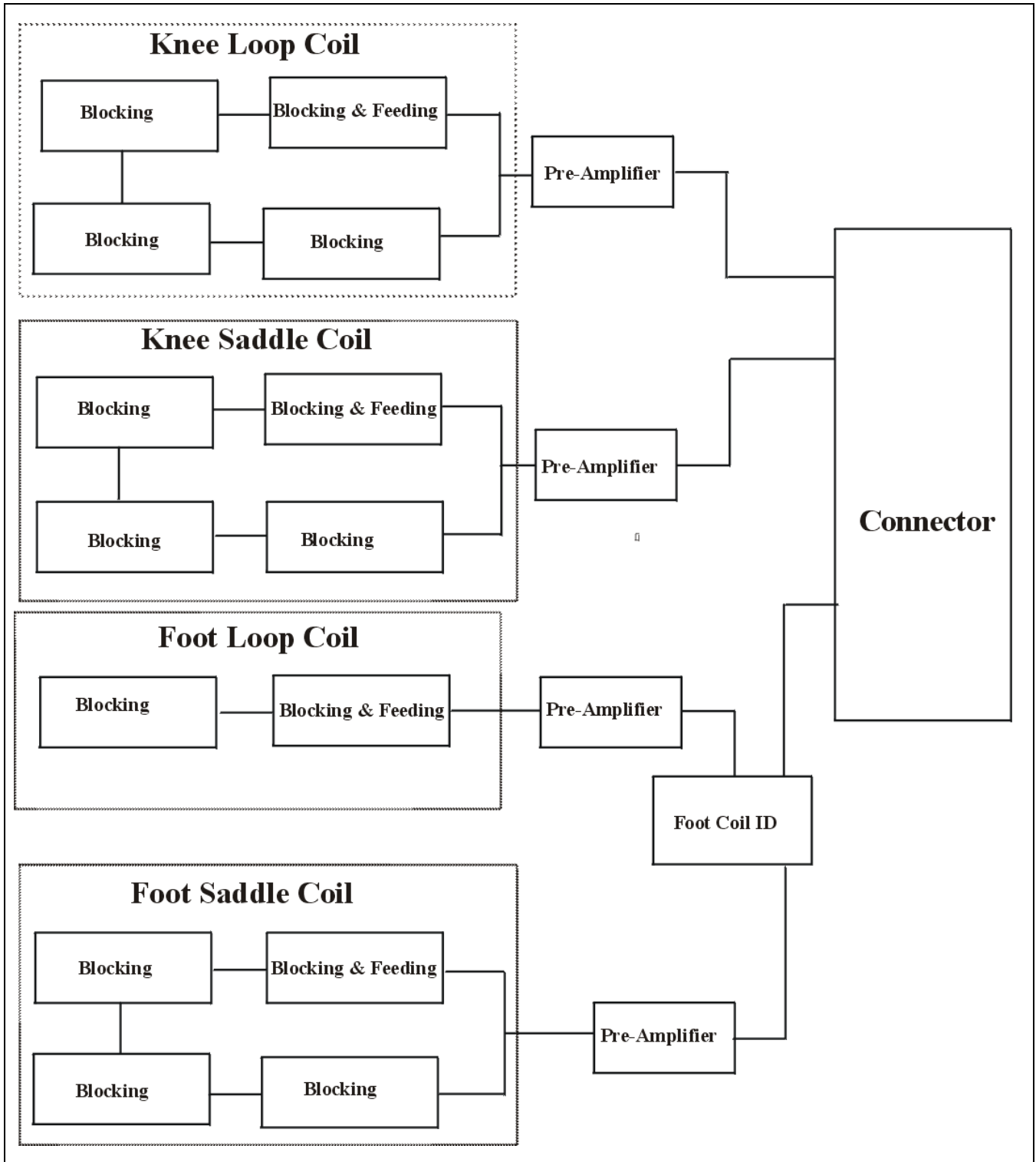

Figure 4: Block diagram of the coil.

## SECTION 2 – SETUP AND CALIBRATION

### 2-1 Coil Installation

#### 2-1-1 Special Install Notes

None.

#### 2-1-2 Configuration

The system will automatically recognize the coil using the Coil ID feature. No configuration is required. If the system doesn't automatically recognize the coil, install the configuration information. The coil configuration information is included in the Appendix; however, that configuration is only current as of the printing of this manual.

### 2-2 Installation Functional Checks

1. From the Scan Desktop, start new scan by selecting [**New Pt**]; set **Patient ID** to “geservice” and **Patient Weight** to “111” pounds. Click [**Patient Position**] to open protocols window.
2. Plug the coil into the patient table and verify the coil indicator light at the side of the coil port turns green. A green light indicates the system hardware identifies the coil.
3. At the operator console, verify the Coil has been properly identified by the system: correct name in **Coil** field and correct picture on the screen.
4. Perform system level Signal to Noise Check. Refer to Service Methods CD; System Level Procedures; Functional Checks; Signal to Noise Check.
5. Perform Section 3-2 Coil Imaging Performance Verification.

### 2-3 Periodic Quality Assurance Check

On a periodic basis, such as during planned maintenance, perform the quality assurance checks outlined below to ensure the coil is operating properly.

1. Check external cable for cracks or cuts.
2. Perform Section 3-2 Coil Imaging Performance Verification and record data values in Data Sheet.

### SECTION 3 – FUNCTIONAL CHECKS

#### 3-1 Scanner Verification

Perform system level Signal to Noise Check. Refer to Service Methods CD; System Level Procedures; Functional Checks; Signal to Noise Check.

#### 3-2 Coil Imaging Performance Verification

##### 3-2-1 Tools Required

TOOLS REQUIRED – TABLE 3-2-1

Description	GE Part #	USAI Part #	Qty
Knee Coil Phantom	2264742-8	150210	1
Foot Attachment Phantom	2264742-4	150133	1
Phantom Positioner	2284544	150134	1

##### 3-2-2 Explanation of Procedure

The image quality check uses the subtraction method to calculate SNR. The method requires two scans to create two phantom images. The signal value is measured from two images, and the noise value is measured from one subtracted image that is generated.

##### Symbols for Hardware and Software Keys

Hardware keys are underlined>. Software keys are indicated using brackets [ ].

##### 3-2-3 Scan Setup

1. From the Scan Desktop, start new scan by selecting [**New Pt**]; set **Patient ID** to “geservice”, **Patient Name** to “QA Scan” and **Patient Weight** to “111” pounds.

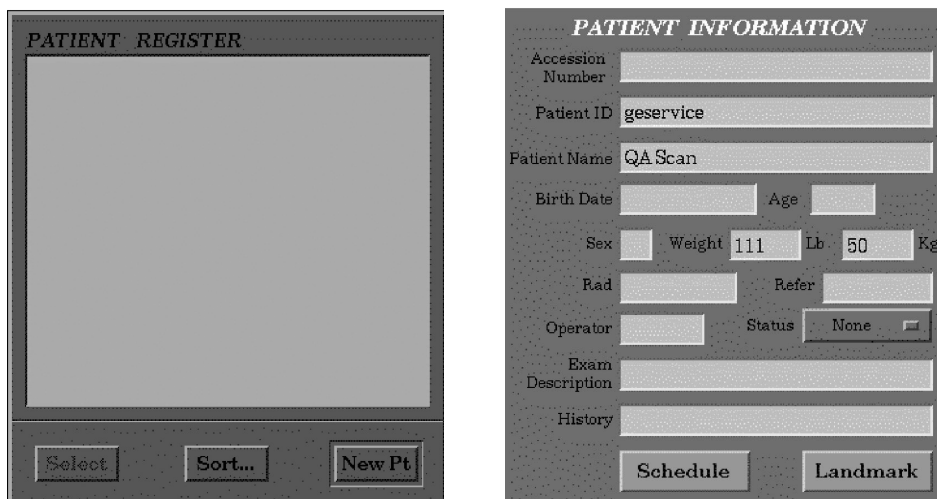

Figure 5: New patient setup and patient information.

2. Remove any other surface coil (if present) from the cradle. Place the foot attachment coil directly on the cradle or place the knee coil on the two pads and on the cradle (see *Figures 6 and 7*). Position the knee or foot phantom on the coil. Connect the coil connector to the coil port.



Figure 6: Positioning the knee phantom.



Figure 7: Positioning the foot phantom.

3. At the magnet, press the “**Alignment Light**” button to turn on the light. Move the cradle to align the coil to the alignment lights as shown in *Figure 8*. Press the “**Landmark**” button to landmark the alignment.

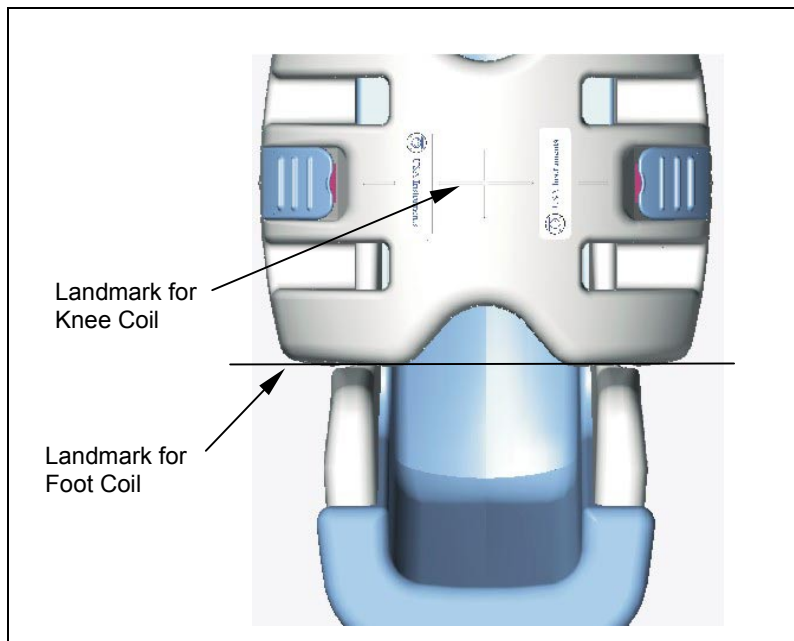

Figure 8: Coil landmarks.

4. Move the coil to scan position by pushing the **Move to Scan** button, ensuring the cable does not get snagged.
5. At the operator console, verify the Coil has been properly identified by the system: correct picture on the screen and correct name in the **Coil** field. If the system does not recognize the coil, refer to Section 2 – Setup and Calibration.
6. Set the protocols using the parameters listed in Scan Protocols – Table 3-2-3.

**SCAN PROTOCOLS – TABLE 3-2-3**

<b>Patient/Exam Information</b>	
Patient ID	geservice
Patient Name	QA Scan
Patient Weight	111 lbs. (50 kg)
Landmark	Nasion
Table Entry	Center
<b>Patient Position</b>	
Patient Position	Supine
Patient Entry	Head First
Coil	Knee(S) / Foot
Series Description	<i>Leave Blank</i>
<b>Imaging Parameters</b>	
Plane	Axial for Knee(S) Sagittal for Foot
Mode	2D
Pulse Seq	Spin Echo
Imaging Options	None
PSD Name	<i>Leave Blank</i>
Protocol	<i>Leave Blank</i>
<b>Scan Timing</b>	
# of Echoes	1
TE	25.0
TR	500
Bandwidth	10.42
<b>Additional Parameters</b>	
<i>no entries required in this area</i>	
<b>Acquisition Time</b>	
Freq	256
Phase	256
NEX	1.0
Phase FOV	1.0
Freq DIR	A/P for Knee(S) S/I for Foot
Auto Center Freq	Peak
Autoshim	On
Contrast	Off
<b>Scanning Range</b>	
FOV	25
Slice Thickness	5
Spacing	0

	<b>I/S Center</b>	<b>P/A Center</b>	<b>R/L Center</b>
<b>Start</b>	0	0	0
<b>End</b>	0		
<b># Slices</b>	1		

### 3-2-4 Phantom Scan

1. Select **[Save Series]** to download the protocols. Select **[Prepare to Scan]**.
2. Using the mouse, point to **[Research Operations]**; click the right mouse button to select **[Display CVs]**.
3. Enter “saveinter” for CV name. Set the current value to “1” and press the enter key. Select **[Accept]** to close the window.
4. Select **[Auto Prescan]** – wait until finished.
5. Select **[Scan]** – wait until finished and then select **[Scan]** again.

### 3-2-5 Create Subtraction Images

1. Select **[Display Icon]** to display the browser.
2. Select the exam named “QA Scan”.
3. After the phantom scan, select **[Add/Sub]** from browser.

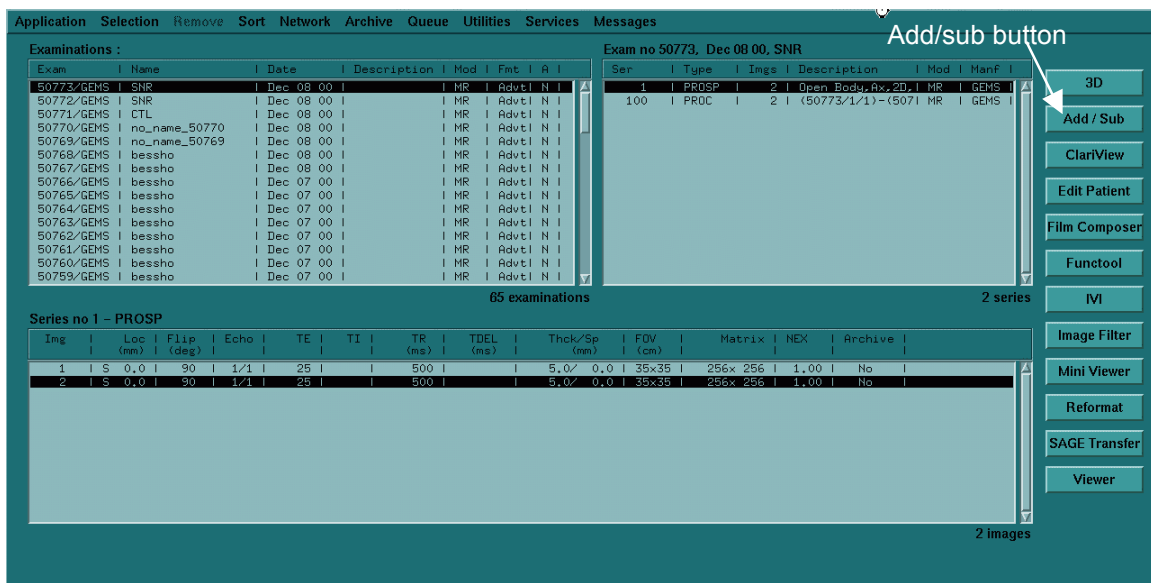

Figure 9: Browser with Add/Sub button.

4. Select MODE [-]; select **[Accept Negative Pixels]**.
5. Select the first image from the browser; then select Image Combination **[Select Set]** (left button on the Image Combination Window).
6. Select the second image from the browser; then select Image Combination **[Select Set]** (right button on the Image Combination Window).
7. Select **[=]**.
8. Repeat the procedure to create subtraction images for the other channel or mode (see Subtraction Images – Table 3-2-5).

**SUBTRACTION IMAGES – TABLE 3-2-5**

Mode	Subtraction Element #	Subtraction Image #
Knee	2	1 - 4
Knee	4	2 - 5
Knee	Composite	3 - 6
Foot	4	1 - 6
Foot	5	2 - 7
Foot	6	3 - 8
Foot	Composite	5 - 10

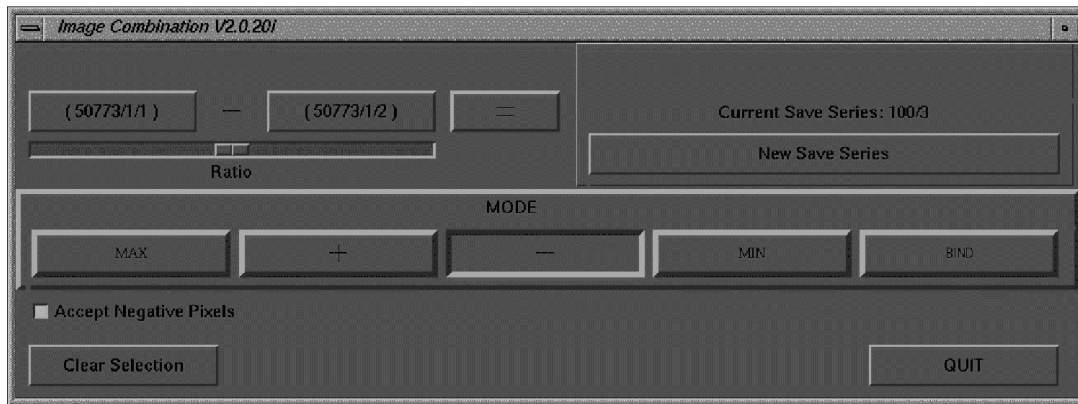

Figure 10: Image Combination Window.

**3-2-6 Setting the Cursor**

1. Select **[Display Icon]** to display the browser.
2. Select the “QA Scan” exam.
3. Select the image to measure (refer to Appendix SNR data sheet). This sheet shows the relation between element and image number. Select **[Mini Viewer]**.
4. Select **[Grid]** to set cursor.
5. Select the circular cursor in **[Measure]**. Adjust the cursor size to 6000mm<sup>2</sup> (+/- 200mm<sup>2</sup>). Use cursor copy (**CTRL + C**) and paste (**CTRL + V**) to easily set the cursor to each image.
6. Position the cursor for the knee coil at the center of the phantom (see *Figure 11*). Position the cursor for the foot attachment at A=A'=A” (see *Figure 12*). Use cursor copy (**CTRL + C**) and paste (**CTRL + V**) to easily set the cursor to each image.

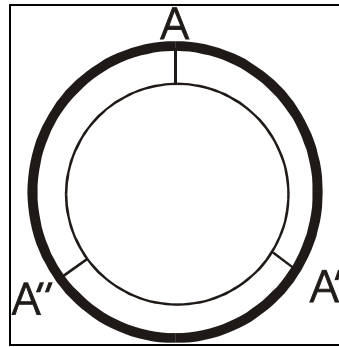

Figure 11: Positioning the cursor for the knee coil.

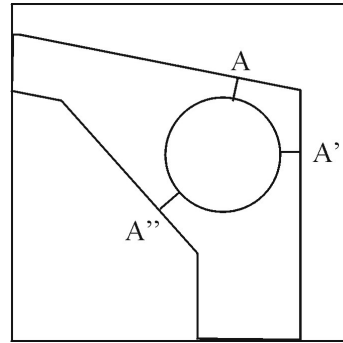

Figure 12: Positioning the cursor for the foot attachment.

### ROI SELECTION – TABLE 3-2-6

Configuration	ROI Type	ROI Area (mm <sup>2</sup> )	ROI Position
Knee	Circular	6000 (± 200)	Center of the phantom (see <i>Figure 11</i> )
Foot	Circular	6000 (± 200)	See <i>Figure 12</i>

### 3-2-7 SNR Image Analysis

#### Signal Measurement

1. Select the phantom images using [**Mini Viewer**].
2. Set the cursor on the phantom (see phantom images).
3. Measure the **mean** values of the first set of phantom images and record them.
4. Measure and record the mean values of the second set of phantom images.
5. Refer to channel images shown in *Figures 13 and 14*.

#### Noise Measurement

1. Select subtracted images in the browser using [**Mini Viewer**]. The series of these images are 100s.
2. Measure the **standard deviation** value of the subtracted images and record them.
3. Measure and record the standard deviation values for the each element.

#### SNR Measurement

SNR is calculated as follows:

$$\text{SNR} = [(\text{mean value1}) + (\text{mean value2})] / (\text{SD} \times 1.414)$$

### SNR Specification

SNR should be greater than or equal to the following numbers:

- Knee small (composite): 205
- Foot (composite): 146

### Individual Element Performance

SNR is calculated for individual elements at the slice location where signal is brightest. For the signal measurement, choose an ROI following the examples shown in *Figures 13 and 14*.

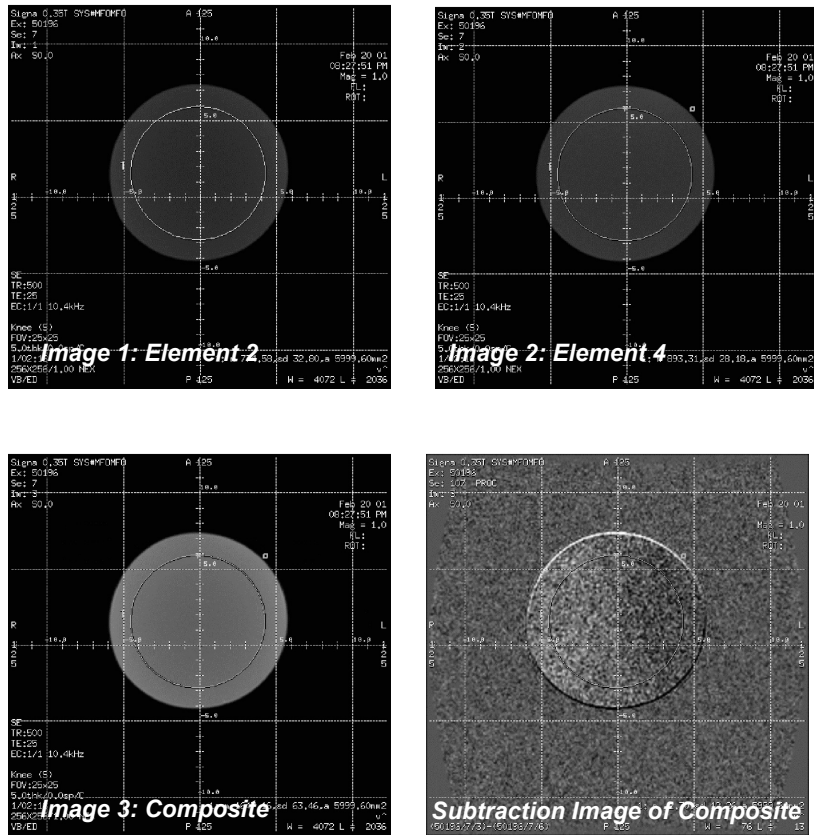

Figure 13: Knee images.

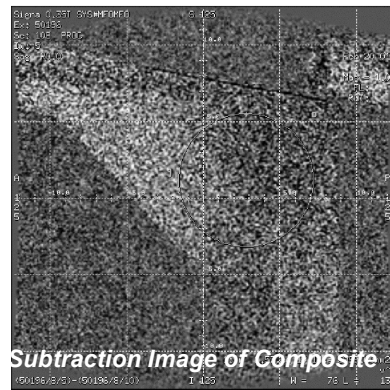
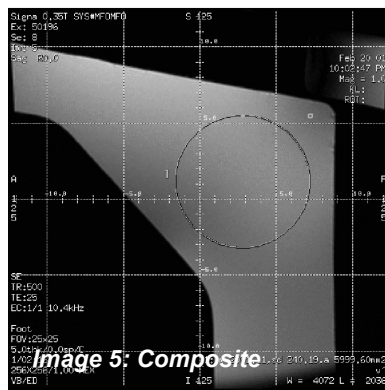
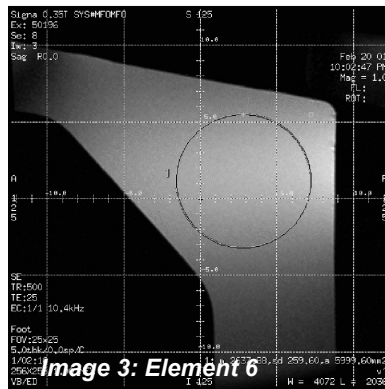
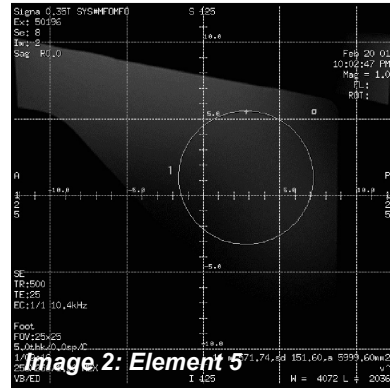
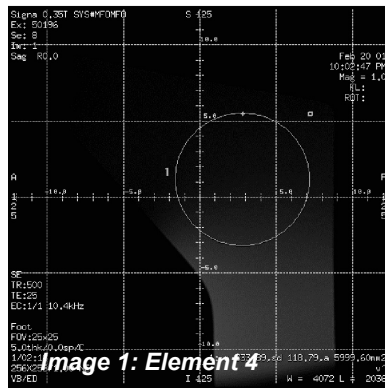

Figure 14: Foot images.

### 3-3 External Cable Check

Step 1 – Using a Digital Multimeter, select the **Diode Test** function.

Step 2 – Refer to the Step 1 column of Table 3-3 for lead placement.

Step 3 – Flex the external cable, especially near the connectors and the strain relief. A reading of 1.200 to 1.800 should remain on the Digital Multimeter with no instability or fluctuations.

Step 4 – If the check in Step 3 fails, replace the cable.

Step 5 – Refer to the Step 2 column of Table 3-3 for lead placement.

Step 6 – Flex the external cable, especially near the connectors and the strain relief. A reading of **infinity** should remain on the Digital Multimeter with no instability or fluctuations.

Step 7 – If the test in Step 6 fails, replace the cable.

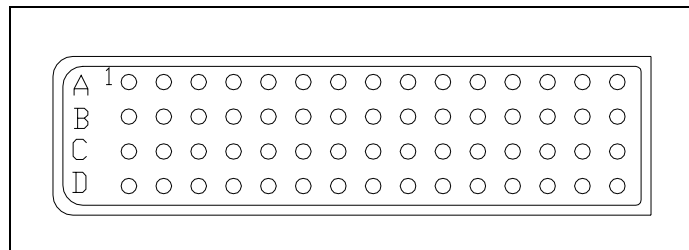

Figure 15: Connector diagram.

### EXPECTED READINGS – TABLE 3-3

Cable	Positive Lead Connection		Negative Lead Connection	
	For Step 1	For Step 2	For Step 1	For Step 2
Knee Loop (PA2)	D2	D15	D15	D2
Knee Saddle (PA4)	D4	D15	D15	D4
Foot Saddle (PA5)	D12	D15	D15	D12
Foot Loop (PA6)	B12	D15	D15	B12

### 3-4 PIN Diodes Check

Step 1 – Using a Digital Multimeter, select the **Diode Test** function.

Step 2 – Refer to the Step 1 column of Expected Readings – Table 3-3 for lead placement.

Step 3 – The reading on the Digital Multimeter should be between 1.200 and 1.800. If the reading is below 1.200, either the output cable is shorted or there is a defective PIN diode. If the reading is above 1.800, there is a defective PIN diode.

Step 4 – Refer to the Step 2 column of Expected Readings – Table 3-3.

Step 5 – The reading on the Digital Multimeter should be **infinity**. If the reading is **infinity** in both directions, either the output cable is open, or a PIN diode is open.

### 3-5 Mechanical Hardware Check

None.

### 3-6 Troubleshooting Tips

Symptom #1: The system reports a coil fault during prescan or does not recognize the coil connection to the system when selected in the software.

Probable Cause	Suggested Actions	Resolution
The coil connector has become disconnected from the system interface.	Check to make sure the coil connector is fully engaged.	Engage connector and try the scan again. Make sure the indicator light on the patient table turns green with the proper coil selected on the operator console.
There is a DC short or open somewhere within the DC path inside the coil.	Check each channel using Table 3-3 - Expected Readings in Section 3-3. Check the coil and associated DC paths with a DVM, in both diode check and resistance modes.	If a short or open is observed, check the output cable by itself (see below). If the cable and PIN diodes are okay, then replace the coil.
The output cable has a short or an open.	Disconnect the cable at the coil and check each coaxial line with a DVM (resistance). Try moving and twisting the cable as you watch the meter to find any intermittent connections. Inspect the center pins of the SMB and Bendix connections for wear and proper engagement into the mating connection	Replace the coil.
There is a problem with the DC bias from the system interface or the coil ID circuitry.	Check to ensure the correct DC bias is being provided to the coil during transmit and receive per GEMS System Service Manual. Try a similar 2-channel coil to see if the same problem occurs	Correct MRI system problem.

Symptom #2: The coil does not pass SNR tests or exhibits poor image quality on patient scans.

Probable Cause	Suggested Actions	Resolution
One or more of the coil channels has a high noise level.	Look at the uncombined images to determine which channel has the problem. Compare the noise standard deviation measurements between channels and system performance logs; they should be approximately the same.	Replace the coil.
One or more of the coil channels has low signal.	Look at the uncombined images to determine which channel has the problem. Compare signal mean measurements between channels and system performance logs.	Replace the coil.
The anterior section of the coil is not fully engaging with the posterior section.	Check the tightness of fit between the anterior and posterior sections of the coil. Make sure the connections are clean and free of debris. Make sure the latch is securing the coil firmly. Check to see that the rubber o-ring for each latch is not stretched or broken.	Clean the connector contacts. Replace the latch mechanics as required. If the problem persists, replace the coil.
Excessive ghosting is causing the noise std. dev. measurements to be artificially high.	Window and level the images down to look at the background for signs of ghosting. Try padding the phantom in the holder.	If padding or changing the phantom position can minimize ghosting, then the problem is caused by excessive vibration elsewhere in the system. If the ghosting is not symptomatic of phantom positioning or padding, then replace the coil.
There is a problem with the DC bias from the system interface or the coil ID circuitry.	Check to ensure the correct DC bias is being provided to the coils during transmit and receive per GEMS System Service Manual.	Correct MRI system DC bias problem.

**Coil Element Information**

**Knee**

element name	not used	loop	not used	saddle	not used	not used	not used	not used	not used
channel number	1	2	3	4	5	6	7	8	N/A
selected channel	no	yes	no	yes	no	no	no	no	N/A
mc bias driver #	1	1	2	2	3	3	4	4	N/A
active bias driver	yes	yes	yes	yes	no	no	no	no	N/A

**Foot**

element name	not used	loop	not used	saddle	foot saddle	foot loop	not used	not used	not used
channel number	1	2	3	4	5	6	7	8	N/A
selected channel	no	no	no	yes	yes	yes	no	no	N/A
mc bias driver #	1	1	2	2	3	3	4	4	N/A
active bias driver	no	no	yes	yes	yes	yes	no	no	N/A

## SECTION 4 – MAINTENANCE

### 4-1 Coil Care



**Detach coil connector from the system before attempting to clean the coil. Do not reattach the connector after cleaning until the coil has dried completely. Electrical shock may result if the coil is attached to the system during cleaning or when it is wet.**



**Do not spray or pour cleaning solution directly on the coil. Do not submerge the coil in the solution. The coil contains sensitive electronics components that could be damaged by the solution.**

The following solutions are recommended for the coil and pad surfaces: (1) a ten percent bleach solution (some discoloration may occur), (2) one ounce commercial dishwashing liquid mixed with one gallon of water or (3) warm water. Apply cleaning solution to a soft cotton cloth and proceed to clean. To prevent soiling of the coil, the user should place a cotton sheet over the coil before positioning the patient. If the coil is soiled, clean the coil as described above.

### 4-2 Special Care Requirements

Prior to returning a coil for service, use a ten percent bleach solution (as described above) to eliminate risk of exposure to potentially infectious materials.

## SECTION 5 – REPLACEMENT

Simple removals that are clearly obvious are not described here.

Unless otherwise noted, the steps for re-assembly are simply the reverse order of the steps described for disassembly.

### 5-1 External Cable Replacement

Step 1 – Remove coil cover.

Step 2 – Disconnect SMB plugs on the cable end from the main feedboard.

Step 3 – Remove the old cable assembly.

Step 4 – Remove the DC plug.

Step 5 – Remove the old cable assembly.

Step 6 – Connect SMB plugs on the new cable assembly to the corresponding receptacles on the main feedboard (knee loop = J5, knee saddle = J8, foot saddle = J12, foot loop = J10).

Step 7 – Connect the DC plug to the feedboard (the red wire should be on the left side).

Step 8 – Close the coil cover.

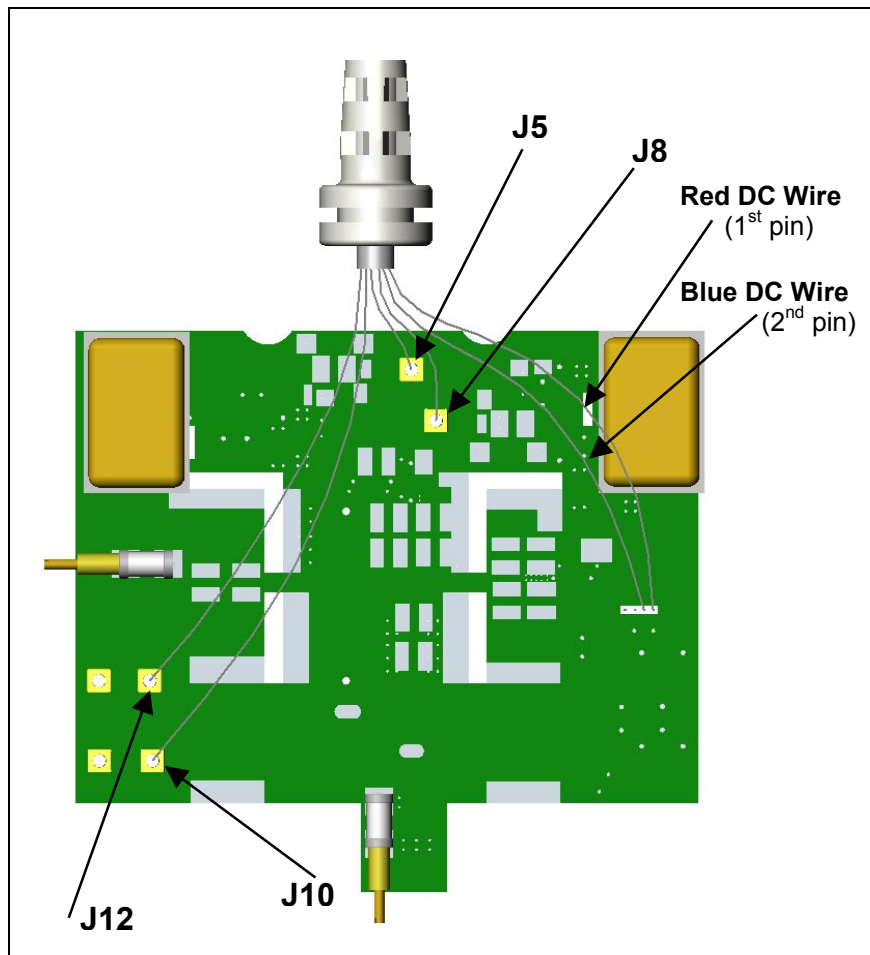

Figure 16: Cable assembly.

## 5-2 Repairing the Latch Mechanism

Step 1 – Using a flat head screwdriver, remove the screws from the anterior section.

Step 2 – Remove the anterior cover.

Step 3 – Using a flat head screwdriver, remove two screws holding the latch-mounting plate to the anterior section.

Step 4 – Replace the latch assembly.

Step 5 – Attach the mounting plate to the anterior section using screws.

Step 6 – Attach the anterior cover using screws.

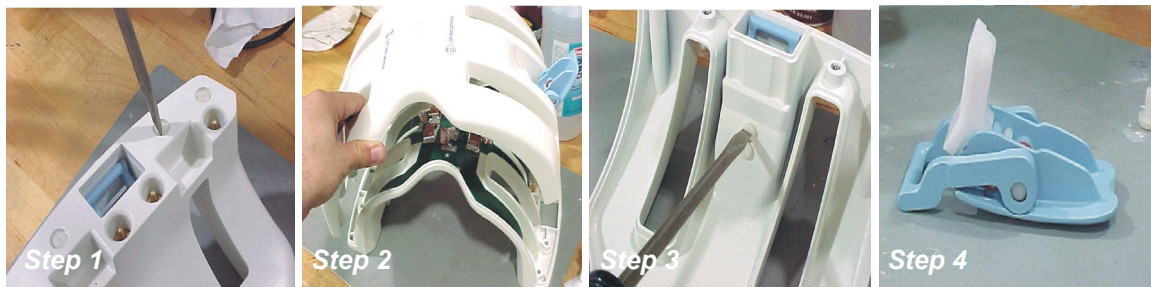

Figure 17: Replacing the latch mechanism.

**SECTION 6 – RENEWAL PARTS**

**6-1 Field Replaceable Units**

**FIELD REPLACEABLE UNITS LIST – TABLE 6-1**

<b>Part Name</b>	<b>GE Part #</b>	<b>USAI Part #</b>
Knee Coil (Standard) and Foot Attachment	2282858	100213
Cable Assembly, Knee (Standard)	2264543	110177
Phantom, Knee Coil	2264742-8	150210
Phantom, Foot Attachment	2264742-4	150133
Phantom Positioner, Knee Coil (Standard)	2284544	150134
Latch Mechanics Repair Kit	2264742-13	110073

**6-2 Other Replaceable Accessories**

**OTHER REPLACEABLE ACCESSORIES LIST – TABLE 6-2**

<b>Part Name</b>	<b>GE Part #</b>	<b>USAI Part #</b>
Patient Comfort Pad, Knee Coil	E8801TA	150128
Transition Pad	E8801TB	150163
Patient Comfort Pad, Foot Attachment, Upper	2284661	150154
Patient Comfort Pad, Foot Attachment, Lower	E8801TE	150155
Coil Shipping Container Set		150137
Phantom Shipping Container Set		150138

**SECTION 7 – APPENDIX**

**7-1 SNR Data Sheet**

Use the table provided below to record the calculated signal to noise ratio (SNR) data obtained from the Functional Checks section.

Date Tested	Configuration	Element	Image #	Signal Mean 1	Signal Mean 2	Noise SD from Subtraction Image	SNR	Spec
	Knee	2	1					
	Knee	4	2					
	Knee	Composite	3					≥205
		R1=		R2=				
		TG=		Freq=				

Foot	4	1						
Foot	5	2						
Foot	6	3						
Foot	None	4	-	-	-	-	-	-
Foot	Composite	5						≥146
		R1=		R2=				
		TG=		Freq=				

Date Tested	Configuration	Element	Image #	Signal Mean 1	Signal Mean 2	Noise SD from Subtraction Image	SNR	Spec
	Knee	2	1					
	Knee	4	2					
	Knee	Composite	3					≥205
		R1=		R2=				
		TG=		Freq=				

Foot	4	1						
Foot	5	2						
Foot	6	3						
Foot	None	4	-	-	-	-	-	-
Foot	Composite	5						≥146
		R1=		R2=				
		TG=		Freq=				

7-2 Schematic

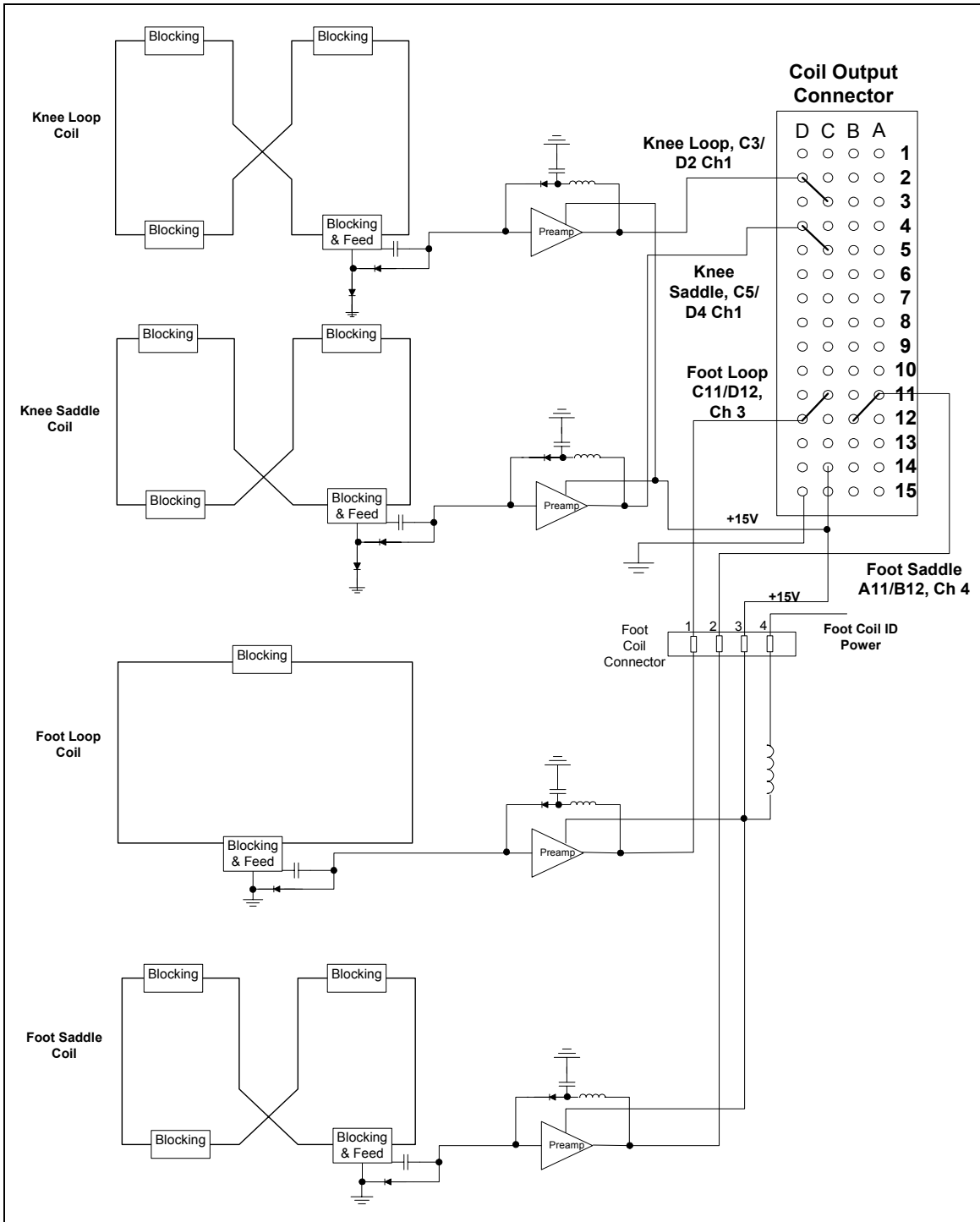

### 7-3 Coil Configuration

Coil Name	Knee(S)	Foot
Coil Code	USAISMKNEE	USAIFOOT
Coil Type	3	3
Extremity Coil	no	no
Cable Loss	1	1
Coil Loss	1.165	1.165
Recon Scale Factor	0.4	0.6
Linear vs. Quadrature	1	1
Multiple Receiver Coil	yes	yes
Number of Receivers	2	4
Starting Receiver ID	0	0
Ending Receiver ID	1	3
Multi-Coil Port Enable	3	6
Multi-Coil Port Error Enable	3	6
Additional Transmit Attenuation	0	0
Number of Fast Receivers	0	0
Starting Fast Receiver ID	4	4
Ending Fast Receiver ID	4	4
Fast TG Start TA	90	90
Fast TG Start RG	12	12
Multi Coil Recon Enable	0	8
Multi Coil Channel Selection	10	56
Attenuation-Q	0	0
Attenuation-I	0	0
Select Quadrature Shifter	0	0
Phased Array T/R Coil for Autoshim	-1	-1
Head Default Freq Dir	1	1
quadRcvCoil	0	0
cfoption	1	1

## REVISION HISTORY

Rev	Date	Author	Primary Reason for Change
A	04/30/01	Reva Zaretsky	First Issue
B	09/01	Reva Zaretsky	Revision to Scan Protocols Table 3-2-3
C	09/28/01	Reva Zaretsky	Revision to Shipping List Table 1-1, Change to Figure 7, Change to Configuration Table
D	11/01/01	Reva Zaretsky	Added Composite SNR Spec for Knee Coil and Foot Coil to SNR Data Sheet; Added SNR Specification to Page 17
E	12/01/01	Reva Zaretsky	Addition made to Configuration Table