

# 1.5T R Series Magnets

## Magnet Handling Manual



5836628-1EN  
Revision 2  
© 2020-2023 General Electric  
Company  
\*Trademark of General Electric  
Company



# Contents

<b>Chapter 1 Getting started .....</b>	<b>5</b>
1.1 Overview.....	5
1.2 Examining packages for damage in transportation.....	7
1.3 Truck loading specifications .....	7
1.4 Predelivery instructions .....	10
<b>Chapter 2 Unloading and moving the magnet.....</b>	<b>13</b>
2.1 Shipping and crate configurations.....	13
2.2 Equipment requirements.....	17
2.3 Removing subsystem crates .....	18
2.4 Handling the crated magnet in transit with a crane.....	19
2.5 Handling the crated magnet in transit with a forklift.....	19
2.6 Removing the shipping cage .....	20
2.7 Removing the shipping crate .....	22
2.8 Unloading and moving the uncrated magnet with a forklift.....	29
2.9 Unloading the uncrated magnet with a crane to ground .....	32
2.10 Lifting the magnet with a crane through the opening in the exterior wall .....	35
<b>Chapter 3 Magnet storage conditions, pending ramp.....</b>	<b>37</b>
3.1 Connecting the magnet to the compressor .....	37
3.2 Connecting the magnet monitoring connections.....	43
3.3 Connecting the warehouse magnet monitoring connections.....	45
3.4 Monitoring the magnet.....	46
3.5 Monitoring the magnet at the warehouse .....	47
<b>Chapter 4 Doing in-transit service and magnet system checks.....</b>	<b>49</b>
4.1 Preparing to do an in-transit helium refill .....	49
4.2 Doing a magnet system check .....	55
<b>Chapter 5 Preparing the scan room.....</b>	<b>57</b>
<b>Chapter 6 Installing a nonseismic vibroacoustic damping mat and leveling the magnet .....</b>	<b>59</b>
6.1 Equipment overview.....	59
6.2 Positioning a non-SV nonseismic mounted vibroacoustic damping mat.....	60
6.3 Positioning a nonseismic mounted SV vibroacoustic damping mat .....	61
6.4 Preparing to move the magnet .....	64
6.5 Moving the magnet into the MR suite.....	68
6.6 Lowering the magnet into position.....	69

---

6.7 Adding leveling shims.....	71
6.8 Leveling a magnet.....	73
6.9 Anchoring the magnet and securing the shim material .....	76
<b>Chapter 7 Installing a seismic vibroacoustic damping mat and leveling the magnet.....</b>	<b>81</b>
7.1 Equipment overview.....	81
7.2 Positioning a non-SV seismic mounted vibroacoustic damping mat.....	82
7.3 Positioning a seismic mounted SV vibroacoustic damping mat .....	84
7.4 Seismic mounting of a vibroacoustic damping mat to the floor .....	87
7.5 Preparing to move the magnet .....	88
7.6 Moving the magnet into the MR suite.....	92
7.7 Lowering the magnet into position.....	93
7.8 Adding leveling shims.....	95
7.9 Leveling a magnet.....	97
7.10 Anchoring the magnet and securing the shim material.....	100
<b>Appendix A Magnet footprint.....</b>	<b>105</b>
<b>Appendix B Preinstallation Manual reference .....</b>	<b>107</b>
<b>Revision History.....</b>	<b>109</b>

# Chapter 1 Getting started

## 1.1 Overview

Safety
<p>Before working in any GE Healthcare MR suite or performing any GE Healthcare service procedure, you must:</p> <ul style="list-style-type: none"> <li>• Have read and understood all hazard conditions and safety requirements in the latest revision of the GE Healthcare <i>MR Service Safety Manual</i> (5452735).</li> <li>• Have successfully completed all relevant GE Healthcare Environmental Health and Safety (EHS) courses (or for non-GE employees, equivalent workplace training courses).</li> <li>• Comply with all site-specific training and workplace safety requirements.</li> </ul> <p>If you have any safety concerns at any time, do not begin work or immediately stop work and move to a safe location. Immediately contact your supervisor or site safety officer for instructions on how to proceed.</p>

This *Magnet Handling Manual* manual addresses moving, storage, delivery, and installation of an R series (as defined by the first character of the magnet serial number) zero boil-off magnet. The sequence of events involved in magnet delivery and installation, along with functions, responsibilities, and associated documentation, are shown in the table below.

**Table 1-1 Magnet handling functions and responsibilities**

	Function	Responsibility	Reference document
1	MR Magnet Safety Document Review and Compliance	GE Project Manager of Installation (PMI), GE Field Engineer and Rigger	The <i>MR Service Safety Manual</i> (5452735).
2	Site Delivery and Review: <ul style="list-style-type: none"> <li>• Access and Route</li> <li>• Clearances</li> </ul>	GE Project Manager of Installation (PMI), GE Field Engineer and Rigger	This <i>Magnet Handling Manual</i> and the appropriate <i>Preinstallation Manual</i> (see <a href="#">Appendix B Preinstallation Manual</a> reference on page 107).
3	Magnet Transportation	Transportation Team, Rigger	<a href="#">Section 1.3 Truck loading specifications on page 7</a> in this manual.
4	Magnet Delivery	Rigger	<a href="#">Chapter 2 Unloading and moving the magnet on page 13</a> in this manual.
5	Put Vibroacoustic Damping Mats in Position	Rigger	<a href="#">Chapter 6 Installing a nonseismic vibroacoustic damping mat and leveling the magnet on page 59</a> or <a href="#">Chapter 7 Installing a seismic vibroacoustic damping mat and leveling the magnet on page 81</a> in this manual.
6	Moving Magnet to MR Suite	Rigger	<a href="#">Chapter 6 Installing a nonseismic vibroacoustic damping mat and leveling the magnet on page 59</a> or <a href="#">Chapter 7 Installing a seismic vibroacoustic damping mat and leveling the magnet on page 81</a> in this manual.

**Table 1-1 Magnet handling functions and responsibilities** (Table continued)

	Function	Responsibility	Reference document
<b>7</b>	Magnet Leveling and Bolt Down	Rigger and GE Field Engineer	<a href="#">Chapter 6 Installing a nonseismic vibroacoustic damping mat and leveling the magnet on page 59</a> or <a href="#">Chapter 7 Installing a seismic vibroacoustic damping mat and leveling the magnet on page 81</a> in this manual.
<b>8</b>	Magnet Cryocooler Connections pending room installation as soon as possible but no later than <b>24 hours</b>	GE Field Engineer	<a href="#">Chapter 3 Magnet storage conditions, pending ramp on page 37</a> in this manual.
<b>9</b>	Initial Magnet Setup and Commissioning: <ul style="list-style-type: none"> <li>• Magnet conversion to operating configuration</li> <li>• Exhaust gas vent connection as soon as possible - must be done prior to ramping magnet</li> <li>• Other initial magnet setup procedures</li> </ul>	GE Field Engineer	"Initial magnet setup" procedure in the <i>Magnet and Cryogen Manual for 1.5T R Series Magnets</i> (5928384-8EN).

Photos and images contained within this manual are representative of the system(s) and configuration(s) shipped. The system received may vary slightly.

The latest release of this manual can be obtained through the SIMS Content Viewer or through your GE Healthcare Field Service Representative. Before using this document, make sure you are using the most current released version of this document.

## 1.2 Examining packages for damage in transportation

Examine all packages closely at delivery. If damage is apparent, do the following:

1. Make sure the notation *damage in shipment* is written on all copies of the freight or express bill before delivery is accepted or signed for by a General Electric representative or a hospital receiving agent.
2. Whether noted or concealed, you must report damage to the carrier immediately upon discovery, or in any event, within 14 days after receipt, and hold the contents and containers for inspection by the carrier. A transportation company will not pay a claim for damage if an inspection is not requested within this 14-day period.
3. Call Global Parts at 1-800-548-3366 (option 6) to file a report of the damage.

### NOTE

Contact your local service coordinator for more information on this process.

## 1.3 Truck loading specifications

Safety
<p><b>NOTICE</b></p> <p>EQUIPMENT DAMAGE RISK</p> <p>Improper transportation can result in damage to the magnet.</p> <p>Review guidelines with the carrier prior to transporting the magnet. Any other shipping configuration must be demonstrated through testing and be approved by GE Medical Systems.</p>
Required conditions
Air ride trailers must be used.
The magnet must be centered on the trailer with the magnet bore parallel to the truck.
The magnet <b>must not</b> be positioned over the trailer axles.
Extreme care must be used during forklift use. The magnet crate must be picked up from the sides only. The forks must be put directly under the four magnet feet. The magnet can be identified by the steel plates attached to the pallet. See <a href="#">Chapter 2 Unloading and moving the magnet on page 13</a> for more detailed handling requirements pertaining to forklift and/or crane moves.
Crate and/or frame top and sides <b>must not</b> be used to secure the magnet to the trailer. Magnets should be secured to the trailer using crate/magnet base.

**Required conditions**

A maximum of two magnets per trailer is allowed. Acceptable dual load configurations are as follows:

- Two 1.5T (HM, PM, R, or RD series) magnets
- One 1.5T (HM, PM, R, or RD series) magnet and one 3.0T (AR or UA series) magnet

**Figure 1-1 Single magnet ground transportation truck loading requirements, tarped configuration (left) and crated configuration (right)**

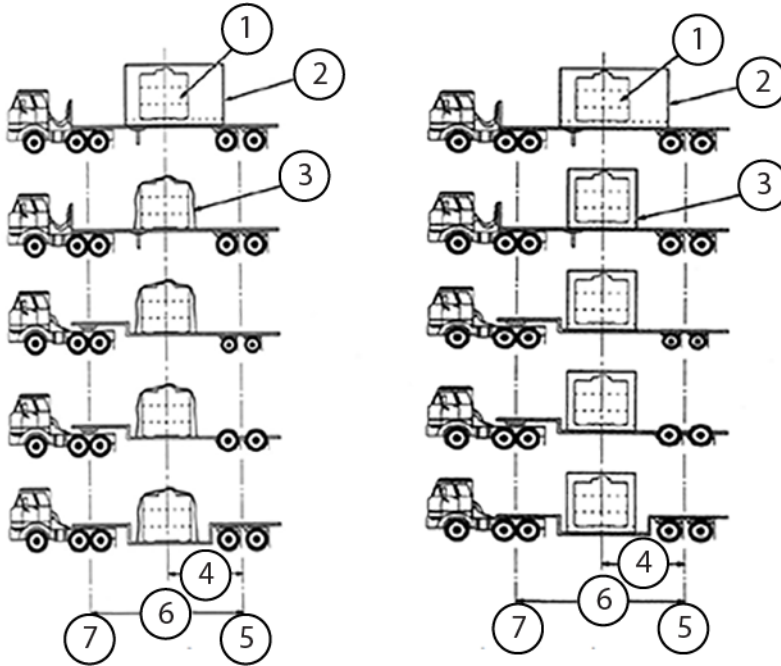

1	Magnet
2	ISO box container
3	Tarp (left) or crate (right)
4	Length from the midpoint to the rear axle centerline (L/2)
5	Rear axle centerline
6	Length from king pin centerline to rear axle centerline (L)
7	King pin centerline

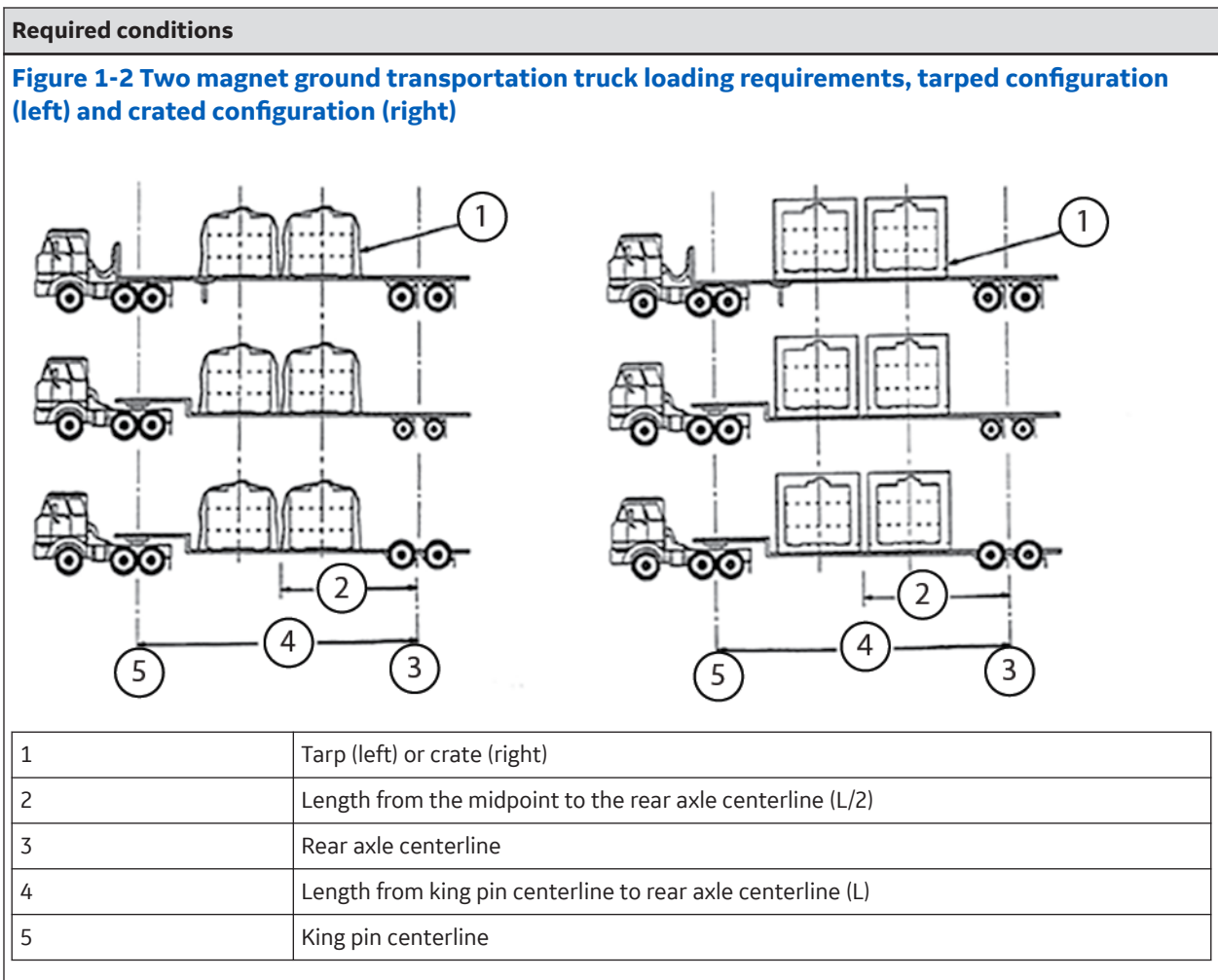

**Table 1-2 Magnet loading specifications**

<b>Max tilt when suspended by lifting lugs</b>	30°
<b>Allowable shipping modes</b>	<ul style="list-style-type: none"> <li>• Airplane (any plane that has openings large enough to accept a magnet)</li> <li>• Air ride trailer (see <a href="#">Figure 1-1 Single magnet ground transportation truck loading requirements, tarped configuration (left) and crated configuration (right) on page 8</a> and <a href="#">Figure 1-2 Two magnet ground transportation truck loading requirements, tarped configuration (left) and crated configuration (right) on page 9</a>)</li> <li>• Boat or ocean-going ship</li> </ul>
<b>Forklift capability</b>	Yes
<b>Shipping temperature</b>	-30 to 50°C (-22 to 122°F)
<b>Maximum shock load</b>	1.5g

## 1.4 Predelivery instructions

### Safety

#### NOTICE

##### EQUIPMENT DAMAGE RISK

Impacts/jolts/drops to the magnet while lifting/moving/lowering the magnet can cause expensive internal magnet damage.

The rigger is responsible for actual equipment/procedures used to lift and move a magnet into the customer facility, including through a raised opening in an exterior wall. The following EXAMPLE procedure only outlines the concept of one method.

Lift/move/lower the magnet smoothly. Do not let the magnet bump or hit anything forcefully. Avoid tilting the magnet more than the maximum tilt (30° from horizontal level). Do not apply any force to the magnet enclosures. Protect all customer surfaces during any and all move operations.

#### NOTICE

##### IMAGE QUALITY RISK

Improperly located anchors can cause image quality issues.

Make sure that all equipment anchors are located in conformance with the site's architectural drawings and are installed and tested per the *Anchor Hardware Requirements for MR Equipment inside RF Shield Room* section of the appropriate *Preinstallation Manual* (see [Appendix B Preinstallation Manual reference on page 107](#)).





1. Before magnet delivery, the GE PMI and rigger must do the following:
  - a. Visit the magnet site with the rigging foreman before magnet delivery to plan the move. GE PMI must hand-deliver a copy of this document to the rigging foreman.
  - b. Review the guidelines for shipping/handling and for equipment/tools with the rigging foreman per [Chapter 2 Unloading and moving the magnet on page 13](#) in this manual.
  - c. Caution the rigger that the magnet is extremely fragile. Sudden jolts can damage the magnet. (Make riggers aware of the cost of a magnet replacement. This usually promotes more care while handling the magnet.)
  - d. Make sure all routes and paths leading to the magnet room are level and free from obstacles and holes. (The rigger will be required to construct platforms where needed.)
  - e. Make sure that clearance dimensions along the path to the magnet room meet the requirements stated in the *Preinstallation Manual* (see [Appendix B Preinstallation Manual reference on page 107](#)). In the case of a magnet being lifted by a crane through a raised opening, make sure the opening is at least 2439 mm (96 inches) wide and 2591 mm (102 inches) tall.
  - f. If roller dollies are to be used, have the rigger bring steel plates to put along the delivery route.
  - g. The rigger must take actions necessary to ensure that walls, floors, and so on along the transportation route/path are protected from potential damage.

2. Before magnet delivery, the GE PMI and Shield Room Vendor must do the following:
  - a. Make sure that floor levelness specifications stated in the *Preinstallation Manual* (see [Appendix B Preinstallation Manual reference on page 107](#)) are met after the finished flooring is installed.
  - b. Make sure that the vent is located according to the specifications stated in the *Preinstallation Manual* (see [Appendix B Preinstallation Manual reference on page 107](#)).
  - c. Make sure that markings are present on the magnet room floor in accordance to the specifications stated in the *Preinstallation Manual* (see [Appendix B Preinstallation Manual reference on page 107](#)).

Page intentionally left blank

## Chapter 2 Unloading and moving the magnet

### 2.1 Shipping and crate configurations

Safety	
	<p><b>⚠ DANGER</b></p> <p><b>POTENTIAL ASPHYXIATION HAZARD</b></p> <p>Loss of magnet vacuum will result in the rapid expulsion of helium gas, which can cause asphyxiation in enclosed areas.</p> <p>Use extreme caution and do not contact or damage the vacuum vessel during magnet transit or siting.</p>
	<p><b>⚠ WARNING</b></p> <p><b>POTENTIAL INJURY</b></p> <p>Magnet is an unbalanced load. Tilting can result in a hazardous condition that can cause magnet damage or serious personal injury.</p> <p>Do the following to avoid tilting:</p> <ul style="list-style-type: none"> <li>• Make sure that the lifting apparatus (crane, spreader beam, and so on) meets the specifications stated in this manual.</li> <li>• Put the spreader beam (if used) parallel to the lifting rails.</li> <li>• Adjust the lifting cables/slings and spreader beam (if used) lift point to level the magnet before fully lifting the magnet off the surface.</li> <li>• Make sure that the entire area where lifting will occur is free of obstructions and unauthorized personnel.</li> <li>• Make sure the surface where the magnet will be put after lifting is flat.</li> <li>• Do not crane lift a magnet during dangerous weather conditions.</li> </ul>
	<p><b>⚠ CAUTION</b></p> <p><b>HEAVY EQUIPMENT</b></p> <p>Two people are required to lift the magnet lifting rails.</p>
	<p><b>⚠ WARNING</b></p> <p><b>RISK OF DEATH, PERSONAL INJURY, OR EQUIPMENT DAMAGE</b></p> <p>The use of used and/or damaged bolts, lock washers, flat washers, and nuts could result in equipment and/or component damage, death, or serious physical injury!</p> <p>Use new, undamaged mounting hardware.</p>

**Safety****NOTICE****COMPONENT DAMAGE RISK**

Improper transportation can result in damage to the magnet.

Tasks in this section are to be done by riggers, not by GE HealthCare Personnel.

Weights referenced in section [2.2 Equipment requirements on page 17](#) are rigging weights (rounded up from actual weights) and are not actual shipping weights. Refer to magnet shipping documents for actual weights of the magnet and crate.

Do not use a crane to lift a magnet that is on a pallet or inside a crate. Crane lifting can only be done using the magnet lifting rails, which are not accessible while the magnet is inside the crate.

**Domestic Shipping Crate (5151624)****Figure 2-1 Shipping crate**

- Approved for use on truck transportation only. (Not approved for flight or ocean usage.)
- Cage/frame positioned over/around magnet after magnet is loaded onto truck.
- Cage must be removed prior to magnet unload from truck (making orange beams accessible).

## 106-inch Shipping Crate (5140792)

Figure 2-2 Fork position

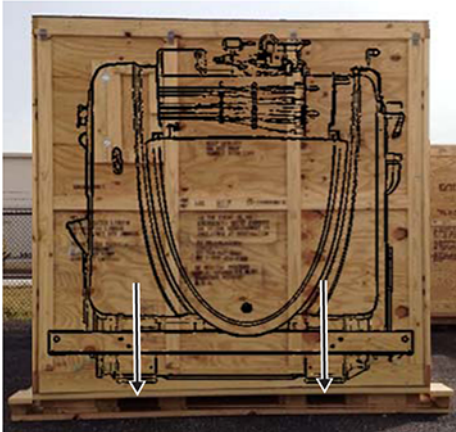

### NOTE

Magnet image superimposed on crates is for reference only. Magnet image shown is representative and may differ from the configuration shipped.

- Approved for use on truck, ocean, or air transportation.
- Forklift approved moves only. (Crane movement of magnet in crate is not permitted.)
- Crate is designed to position forklift forks directly beneath magnet feet - lifting from the side of the magnet, perpendicular to the magnet bore.
- Minimum distance between forks = 1016 mm (40 inches).

## 96-inch Shipping Crate (5334870)

Figure 2-3 Fork position

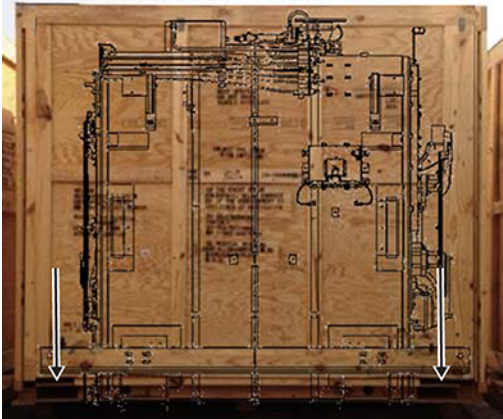

### NOTE

Magnet image superimposed on crates is for reference only. Magnet image shown is representative and may differ from the configuration shipped.

- Approved for use on truck, ocean, or air transportation.
- Forklift approved moves only. (Crane movement of magnet in crate is not permitted.)
- Crate is designed to position forklift forks beneath orange lifting beams mounted onto magnet feet – li ting from the side of the magnet, perpendicular to the magnet bore.
- Minimum distance between forks = 2060 mm (81.1 inches).

## 2.2 Equipment requirements

**Table 2-1 Forklift requirements\***

Item and quantity	Equipment specification/rating		Furnished by	Function
Forklift quantity = 1	Magnet weight only (as shipped configuration with gradient, does not include crate)	5490 kg (12,100 lbs)	Rigger	Unloading or moving magnet
	Crated magnet weight	6396 kg (14,100 lbs)		
	Magnet only - minimum distance between forks using lifting rails	2032 mm (80 inches)		
	Crated magnet - minimum distance between forks	96-inch Shipping Crate (5334870): 2060 mm (81.1 inches) 106-inch Shipping Crate (5140792): 1016 mm (40 inches)		
	Minimum fork length	2363 mm (93 inches)		
*Forklift and forklift equipment must be rated for the referenced magnet loads.				

**Table 2-2 Crane requirements\***

Item and quantity	Equipment specification/rating		Furnished by	Function
Crane quantity = 1	Magnet weight only (as shipped configuration with gradient, does not include crate)	5490 kg (12,100 lbs)	Rigger	Unloading or moving magnet
	Crate weight only	908 kg (2,000 lbs)		
Spreader beam quantity (if used) = 1	Distance between lifting points, underside of spreader beam	2286 mm to 2439 mm (90 inches to 96 inches)		
Slings, hoists, bridles, shackles	Requirement to be determined by rigger. <b>NOTE</b> Refer to magnet weights noted above.			
*Crane and crane equipment must be rated for the referenced magnet loads.				

**Table 2-3 Miscellaneous equipment and tools\***

Item	Equipment/tool required	Responsible	Function
Magnet mechanical interface drawing (bare magnet) <b>NOTE</b> Interface drawings may not contain shipping configurations and are for reference only	See clearance dimensions in <a href="#">6.4 Preparing to move the magnet on page 64</a> .	Project manager of installation (PMI)	Identifying magnet dimension and features
Magnet weight only (as shipped configuration with gradient, does not include crate)	5490 kg (12,100 lbs)	Reference	Moving the magnet
Hydraulic or toe jack	Must support one end of magnet on two jacks or both ends of magnet on four jacks. <b>NOTE</b> Refer to magnet weights noted above.	Rigger	Raising the magnet for roller dollies or leveling plates
Roller dollies	Must support magnet on four dollies. <b>NOTE</b> Refer to magnet weights noted above.	Rigger	Moving the magnet
Levels (length)	Level 1: 610 mm to 915 mm (24 inches to 36 inches) Level 2: < 305 mm (12 inches)	Rigger	Leveling the magnet
Magnet Leveling Kit	46-260888G4	Rigger	Leveling the magnet

\*Miscellaneous equipment and tools must be rated for the referenced magnet loads.

## 2.3 Removing subsystem crates

1. Carefully inspect all packaging for damage that may have occurred during shipping.
2. Remove all subsystem crates, except the magnet crate, from the trailer/transport using a crane or forklift. To handle the magnet crate in transit from the truck or plane, see [2.5 Handling the crated magnet in transit with a forklift on page 19](#).
3. Inspect all crates for visible damage. Report any damage you find in conformance with the [1.2 Examining packages for damage in transportation on page 7](#) procedure.
4. Move subsystem crates to a receiving location protected from the weather, preferably close to and at the same level as the MR suite/magnet room.

## 2.4 Handling the crated magnet in transit with a crane

Do not use a crane to move the magnet if it is still in the crate. Using a crane requires clear access to the orange lifting beams, which are not accessible while the magnet is inside the crate.

## 2.5 Handling the crated magnet in transit with a forklift

<b>Safety</b>
<p><b>NOTICE</b></p> <p><b>EQUIPMENT DAMAGE RISK</b></p> <p>Improper transportation during forklift operations can result in magnet damage.</p> <p>Forklift must meet the minimum capacity and dimension requirements stated in section <a href="#">2.2 Equipment requirements on page 17</a>.</p> <p>The magnet must be picked up from the magnet side orientation only with the forks inserted into the designated slots on the crate.</p> <p>Avoid sudden jolts. Do not allow the crate/pallet to bump anything forcefully.</p> <p>Avoid tilting the magnet/crate/pallet package more than the maximum tilt specified (30° from the horizontal level).</p>

1. Position a forklift beside the magnet crate/pallet meeting the requirements stated in section [2.2 Equipment requirements on page 17](#).
2. Carefully insert the forklift forks completely into the holes in the long side of the shipping pallet.

**Figure 2-4 Forklift lifting points of magnet/crate/pallet package**

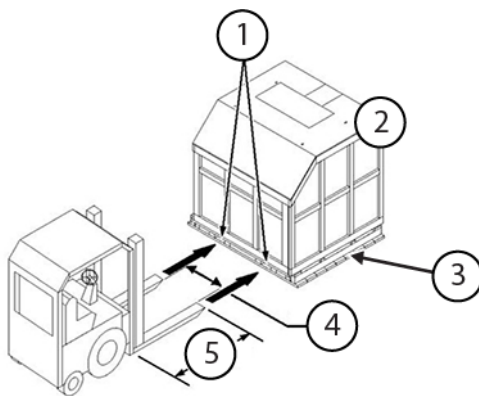

1	Insert forks here only
2	Crate
3	Pallet
4	Crated magnet - minimum distance between forks: 96-inch Shipping Crate (5334870): 2060 mm (81.1 inches) 106-inch Shipping Crate (5140792): 1016 mm (40 inches)
5	Minimum fork length, 2363 mm (93 inches)

3. Smoothly lift the crate/pallet with the forklift, and move the crate/pallet to the desired location.

**NOTE**

Magnet lift must be perpendicular to magnet bore. Crate slots for forklift are designed to ensure proper lift orientation.

4. Lower the entire package to rest on a flat, smooth surface. Do not rest the magnet/crate/pallet on any surface that is not flat or strong enough to support the magnet/crate/pallet package.
5. Avoid tilting the magnet; every effort should be made to minimize tilt during transport or movement. Tilt must not exceed 30° from the horizontal level.

## 2.6 Removing the shipping cage

**Safety****NOTICE****EQUIPMENT DAMAGE RISK**

Improper removal of the shipping cage can result in damage to the magnet.

Do not use a crane to move the magnet if it is still in the cage. If you are using a crane, you need clear access to the orange lifting beams, which are not accessible while the magnet is inside the cage.

Remove the magnet's shipping cage while the magnet/cage/pallet package is on the trailer/transport.

**Safety**

**NOTICE**

**EQUIPMENT DAMAGE RISK**

Care must be taken not to scrape or hit the sides of the magnet. The magnet is shipped inside plastic bubble wrap. The bubble wrap should be left intact until the magnet is set down inside the magnet room. The sample shipping cage configuration (domestic shipping option) below shows intact bubble wrap.

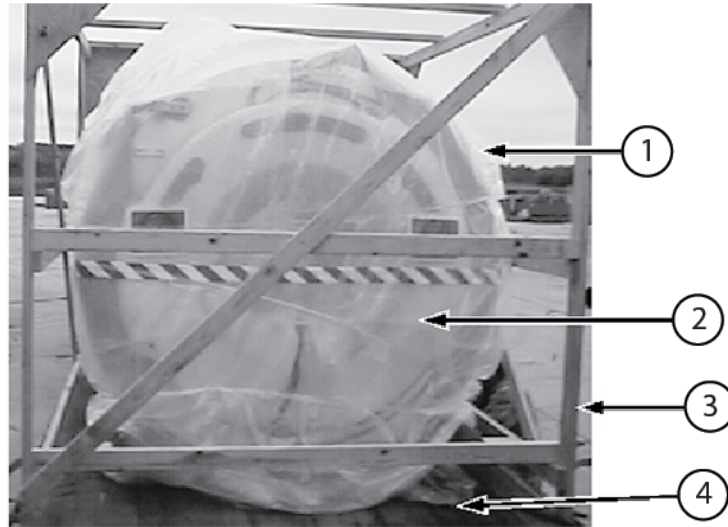

1	Plastic bubble wrap
2	Magnet
3	Cage
4	Pallet

1. Remove the driver-supplied tarp from the shipping cage.
2. Unstrap the cage if any straps were applied. Then unchain the magnet from the flatbed.
3. To remove the shipping cage from the magnet, follow the steps below for one of the options:

<b>Using a crane</b>	<ol style="list-style-type: none"> <li>1. Strap the frame in four locations.</li> <li>2. Lift the cage straight up and move it away from the magnet.</li> </ol>
<b>Not using a crane</b>	<ol style="list-style-type: none"> <li>1. Unbolt the boards on one end of the cage.</li> <li>2. Move the cage away from the magnet in the other direction.</li> </ol>

## 2.7 Removing the shipping crate

### Safety

**NOTICE****EQUIPMENT DAMAGE RISK**

Improper removal of the shipping crate can result in damage to the magnet.

Do not use a crane to move the magnet if it is still in the crate. If you are using a crane, you need clear access to the orange lifting beams, which are not accessible while the magnet is inside the crate.

Remove the magnet's shipping crate while the magnet/crate/pallet package is on the trailer/transport.

Damage to the magnet and/or magnet enclosures may result if the crate is removed while the crate's side panels are in their closed (shipping) position, or if the crate is disassembled while the magnet is inside the crate.

Do not remove any lag screws on the crate or pallet until the crane is positioned, and the slings/cable bridles are attached to the lifting rings on the crate.

1. Remove the driver-supplied tarp from the shipping crate.
2. Unchain the crate from the flatbed.
3. Position a crane meeting the specifications in [Table 2-2 Crane requirements\\*](#) on [page 17](#) above the center of the crate.

- Attach the slings/cable bridles of a spreader beam to the lifting rings on top of the crate.

**NOTE**

Either a hook/shackle and slings or a spreader beam and sling/cable bridles may be used during crate removal.

**Figure 2-5 Crane positioning, lag screw removal to open crate side panels**

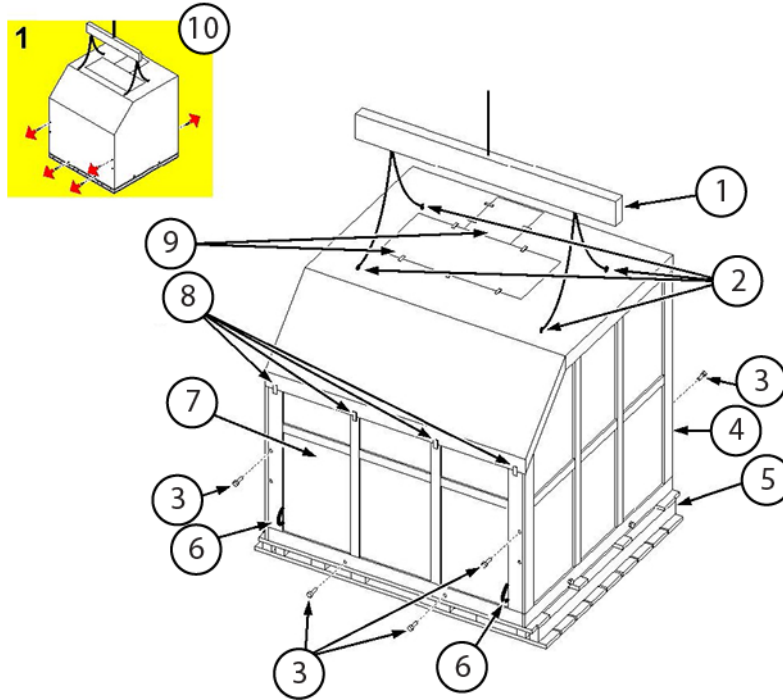

1	Spreader beam with slack lifting straps/cables
2	Four lifting rings for lifting crate
3	Lag screw
4	Front of crate
5	Front of pallet
6	Rope handle
7	Crate side panel
8	Side panel hinges
9	Access panels
10	Graphic on crate

- Remove the lag screws along the lower edges of the crate's left and right side panels that secure those panels to the pallet. Do not remove the lag screws securing the crate's front and back end panels to the pallet until after the crate's side panels are secured in their open position.
- Remove the lag screws securing the crate side panels to the crate end panels. Do not remove the hinges along each crate side panel's upper edge.

7. Pull open the crate's left and right side panels using the rope handle on each side panel. The crate's left and right side panels are hinged along their upper edges.

**Figure 2-6 Securing crate side panels in open position**

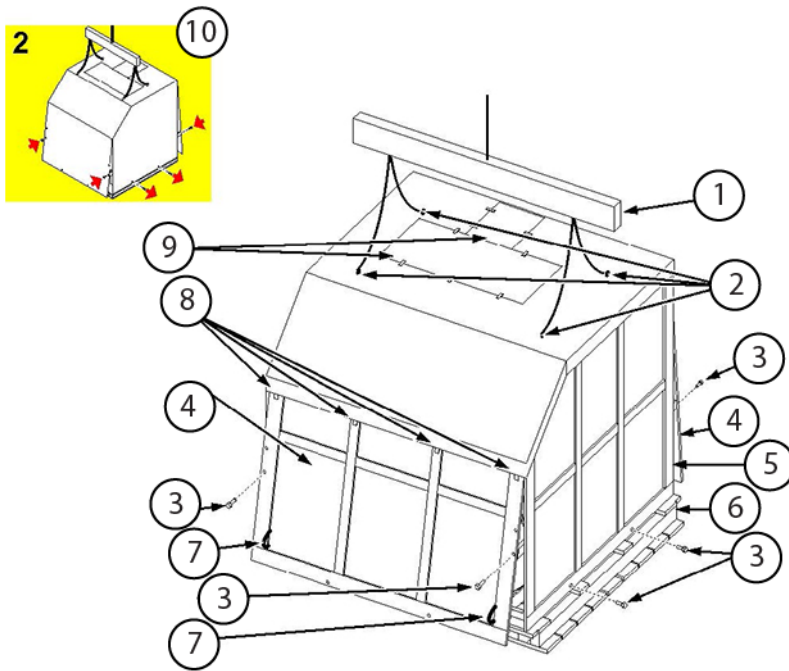

1	Spreader beam with slack lifting straps/cables
2	Four lifting rings for lifting crate
3	Lag screw
4	Crate side panel
5	Front of crate
6	Front of pallet
7	Rope handle
8	Side panel hinges
9	Access panels
10	Graphic on crate

**NOTE**

This figure shows the use of a spreader beam and cable bridles/slings. You can also use a hook or shackle and slings. All equipment must meet or exceed the size and loading specifications stated in this manual.

8. Swing the wooden block found inside each vertical corner of the crate outward.

**Figure 2-7 Rear view of shipping crate with side panels raised**

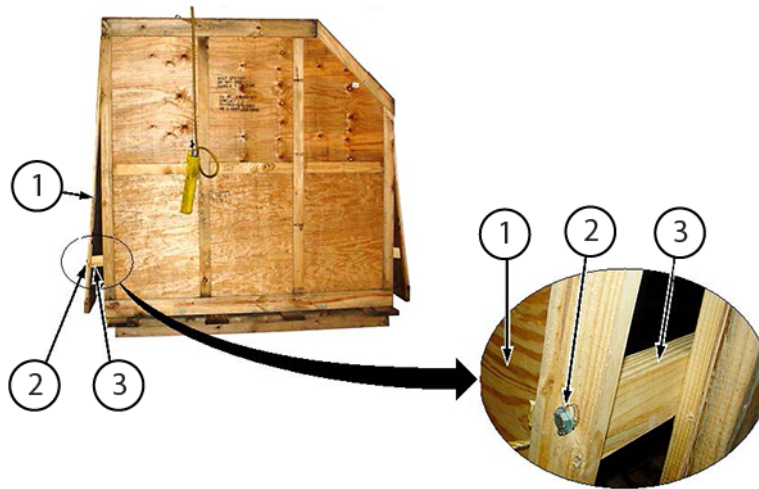

1	Side panel
2	Lag screw
3	Wooden block

9. Attach the loose end of each block to the adjoining side panel using one of the lag screws removed previously.
10. Remove the lag screws along the lower edges of the crate's front and back end panels that secure those panels to the pallet. Refer to [Figure 2-6 Securing crate side panels in open position on page 24](#).

11. Tighten the slings/cable bridles and carefully begin lifting the crate. (Refer to graphic 3 on the shipping crate.) If the crate does not remain approximately level, carefully lower the crate and adjust the lifting configuration, then lift the crate again.

**Figure 2-8 Lifting the crate using a crane**

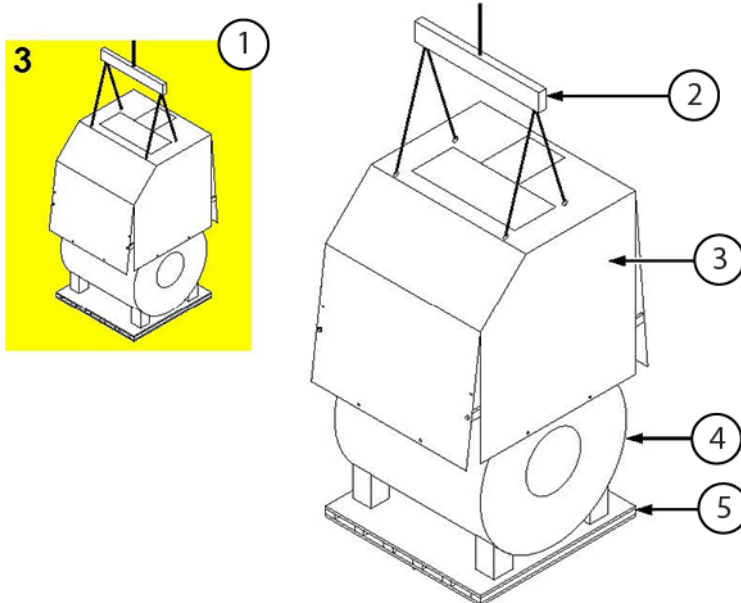

1	Graphic on crate
2	Spreader beam with slack lifting straps/cables
3	Crate
4	Magnet
5	Pallet

**NOTE**

This figure shows the use of a spreader beam and cable bridles/slings. You can also use a hook or shackle and slings. All equipment must meet or exceed the size and loading specifications stated in this manual.

12. Using the crane, lift the crate top off the magnet's shipping pallet and fully above and clearing the magnet.
13. Put the crate in a clear area.
14. Follow the appropriate instructions to remove the hardware securing the magnet.

Hardware	Removal procedure
<b>Bolts securing magnet feet to the pallet</b>	Unbolt and remove the four bolts (one per magnet foot) securing the magnet feet to the pallet.

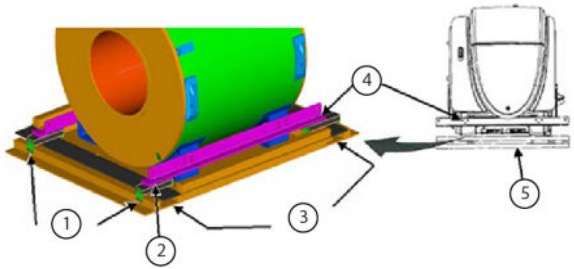
Hardware	Removal procedure										
	<p><b>Figure 2-9 Unbolting the magnet from a shipping pallet</b></p> 										
<p><b>Lag screws securing the magnet through orange lifting beams</b></p>	<p>Remove eight 5/8 inch x 3 inch lag screws securing the magnet to the pallet through the <u>orange</u> lifting beams.</p> <p><b>Figure 2-10 Unbolting the magnet from the shipping pallet</b></p>  <table border="1" data-bbox="889 1037 1469 1360"> <tbody> <tr> <td>1</td> <td>Forklift point to pallet, 3/8 inch x 3 inch lag screw, quantity 32</td> </tr> <tr> <td>2</td> <td>Lift beam to forklift point, 5/8 inch x 3 inch lag screw, quantity 8</td> </tr> <tr> <td>3</td> <td>Forklift access, 9.5 inches x 4 inches</td> </tr> <tr> <td>4</td> <td>Two lag screws in each location, attached to the lifting beams</td> </tr> <tr> <td>5</td> <td>Pallet</td> </tr> </tbody> </table>	1	Forklift point to pallet, 3/8 inch x 3 inch lag screw, quantity 32	2	Lift beam to forklift point, 5/8 inch x 3 inch lag screw, quantity 8	3	Forklift access, 9.5 inches x 4 inches	4	Two lag screws in each location, attached to the lifting beams	5	Pallet
1	Forklift point to pallet, 3/8 inch x 3 inch lag screw, quantity 32										
2	Lift beam to forklift point, 5/8 inch x 3 inch lag screw, quantity 8										
3	Forklift access, 9.5 inches x 4 inches										
4	Two lag screws in each location, attached to the lifting beams										
5	Pallet										

15. Visually examine the witness marks on each bolt and orange lifting rail at each of the four magnet feet. Look for witness mark misalignment between the nut/bolt head and the orange lifting rail.

**NOTE**

See the examples below for correctly aligned witness marks.

**Figure 2-11 Legacy process, pre-2023 and possible storage**



**Figure 2-12 New process, starting mid-2023**



- If witness marks are aligned correctly, continue with [Step 16](#).
- If witness marks do not align as shown above, complete these steps:
  - a. Make sure the rails are installed against the magnet feet at all four locations.
  - b. Look inside of the magnet foot. If a through bolt is used (new process), make sure the lock washer is compressed under the bolt head. If it is not, tighten the bolt until the lock washer is compressed, but do not exceed 90 ft-lbs (122 N m).

**NOTE**

If the nut turns (new process only) but does not tighten, then the bolt hole on the magnet foot was drilled out and the head of the bolt (which is inside the magnet foot) will need to be held by a second wrench while torquing the nut.

- c. Torque the bolt head (legacy) or nut (new process) to 90 ft-lbs (122 N m) on the outside of the orange rail.

**NOTE**

Do not use powered torque drivers. Powered drivers may supply higher torque that can damage the bolts. Do not overtighten the bolts/nuts.

- d. Use a permanent marker to add a new witness mark only on the bolt or nut that was just torqued.
  - e. Continue with [Step 16](#).
16. Rig and lift the magnet off the pallet in conformance with section [2.8 Unloading and moving the uncrated magnet with a forklift on page 29](#) or section [2.9 Unloading the uncrated magnet with a crane to ground on page 32](#) of this manual.

## 2.8 Unloading and moving the uncrated magnet with a forklift

### Safety

#### CAUTION



#### POTENTIAL INJURY HAZARD

Pushing magnet enclosures may result in bodily injury to personnel.

Do not push magnet enclosures. Follow the directions on the six "Do Not Push" signs (one on each side, and two on each end).



#### NOTICE

#### EQUIPMENT DAMAGE RISK

Improper transportation can result in magnet damage.

Do the following to prevent magnet damage:

- Do not apply any force to the magnet enclosures.
- Only use equipment/tools that meet the specifications stated in [section 2.2 Equipment requirements on page 17](#).
- Do not move the magnet to the MR Suite while the magnet is on its shipping pallet. Before moving the magnet to the MR Suite, refer to [Chapter 2 Unloading and moving the magnet on page 13](#).

**Safety****NOTICE****EQUIPMENT DAMAGE RISK**

Improper transportation during forklift operations can result in magnet damage.

Forklift must meet the minimum capacity and dimension requirements stated in section [2.2 Equipment requirements on page 17](#).

The magnet must be picked up from the magnet side orientation only with the forks inserted into the designated slots on the crate.

Forklift forks can damage the magnet enclosure or components. Use protective padding around the forks.

Avoid sudden jolts. Do not let the crate/pallet bump or hit anything forcefully.

Avoid tilting the magnet/crate/pallet package more than the maximum tilt specified (30° from the horizontal level).

**NOTE**

The rigger is responsible for actual equipment/procedures used to lift and move a magnet into the customer facility, including through a raised opening in an exterior wall. The following procedures are guidelines only. It is the responsibility of the rigger to safely move the magnet into the facility.

1. **NOTE**

See [Step 15](#) in [2.7 Removing the shipping crate on page 22](#) for the procedure on examining witness marks before lifting with the orange rails.

Position a forklift that meets the specifications in section [2.2 Equipment requirements on page 17](#) at the side of the magnet facing the magnet. Put the forks under the lifting rails to the outside of the magnet feet.

**Figure 2-13 Forklift under lifting rails**

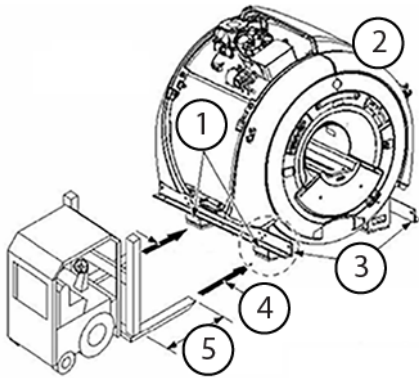

1	Magnet feet
2	Magnet (protective wrap not shown)
3	Lifting rails
4	2032 mm (80 inches) inside forks, minimum
5	2363 mm (93 inches) minimum

**NOTE**

Figure is not to scale. Put the forks under the lifting rails, outside of the magnet feet.

2. Wrap the full length of each fork with protective padding material to prevent damage to the magnet's enclosure.
3. Carefully drive the forklift until the forks are completely under both lifting rails in the areas shown in [Figure 2-13 Forklift under lifting rails on page 31](#).

**NOTE**

The forks must be positioned under both ends of the lifting rails outside of and 254 mm (10 inches) away from the magnet feet. The outsides of the feet are 1524 mm (60 inches) apart. The lifting rails are 2388 mm (94 inches) long.

4. Lift the forks to right below the lifting rails, adjust the distance between forks so that padded forks lightly touch the enclosure, and finish raising the forks to the lifting rails.
5. Lift the magnet with the forklift.
6. Smoothly move the magnet to the desired location, and carefully lower to rest on a flat surface.

## 2.9 Unloading the uncrated magnet with a crane to ground

### Safety



#### **WARNING**

##### POTENTIAL SERIOUS INJURIES

Moving a magnet through a raised opening in an exterior wall can result in serious injuries and magnet/equipment damage.

Do the following before moving the magnet:

- Make sure a complete walk-through of the crane lift process was done prior to the actual event to make sure all process details are covered.
- Make sure all necessary equipment is on-site and inspected for safety and load ratings.
- Make sure all necessary personnel are trained and ready.
- Make sure that the entire area where lifting will occur is free of obstructions and unauthorized personnel.
- Make sure the surface where the magnet will be put after lifting is flat.
- Do not crane lift a magnet during dangerous weather conditions.



#### **WARNING**

##### POTENTIAL INJURY HAZARDS

Improper lifting of the magnet may be hazardous to personnel and can result in damage to the magnet and equipment.

Make sure that the entire area where lifting will occur is free of obstructions and unauthorized personnel.

Make sure that the surface where the magnet will be put after lifting is flat.

#### **NOTICE**

##### EQUIPMENT DAMAGE RISK

Improper transportation can result in expensive internal damage to the magnet.

Avoid sudden jolts. Lift/move/lower the magnet smoothly. Do not allow the magnet to bump or hit anything forcefully.

Avoid tilting the magnet more than the maximum tilt (30° from the horizontal level).

Do not apply any force to the magnet enclosures.

Do not crane lift a magnet that is on a pallet or inside a cage or crate.

Crane lifting can only be done using the magnet lifting rails, which are not accessible while the magnet is inside a cage or crate.

**Safety****NOTICE****EQUIPMENT DAMAGE RISK**

Improper crane transportation can result in damage to the magnet.

Do not crane lift crated/palleted magnets. Crated/palleted magnets must be handled in conformance with the other sections in [Chapter 2 Unloading and moving the magnet on page 13](#) of this manual.

Only a rigger should unload and move the magnet.

**NOTE**

The rigger is responsible for actual equipment/procedures used to lift and move a magnet into the customer facility, including through a raised opening in an exterior wall. The following procedures are guidelines only. It is the responsibility of the rigger to safely move the magnet into the facility.

1. Make sure that there are no obstructions in the area where lifting will occur and that a flat surface is available to position the magnet after lifting.
2. Position the hook of a crane and spreader beam (if used), which meet the specifications stated in section [2.2 Equipment requirements on page 17](#), centrally over the magnet to ensure a vertical lifting force on the lifting cables/slings. If a spreader beam is not used, make sure that the strap length and crane lifting height are long enough so that the straps do not contact any part of the magnet above the magnet lifting beam and the magnet can reach the desired height.

**NOTE**

Align the spreader beam parallel to the magnet bore.

**Figure 2-14 Crane lift configuration, magnet side view (left) and front view (right)**

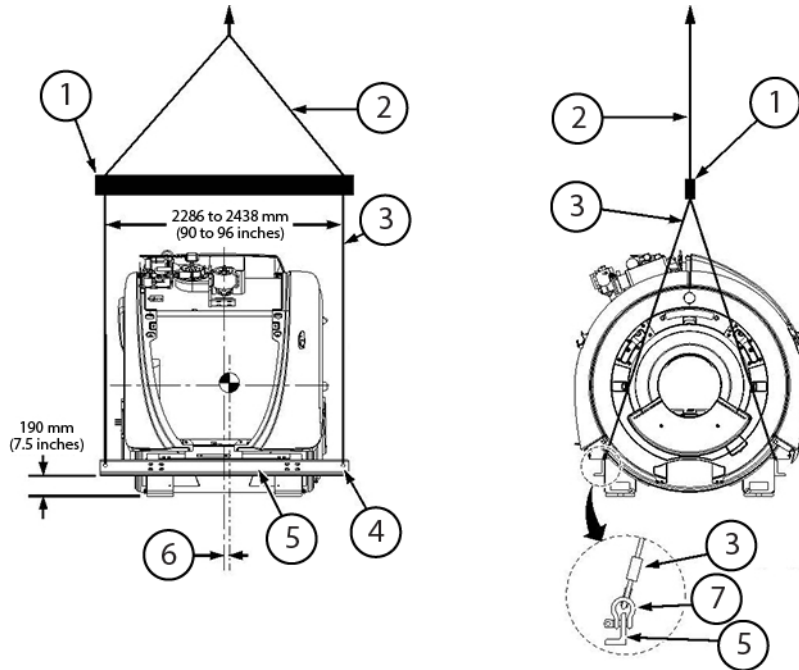

1	Spreader beam with top rigging
2	Two-legged cable bridle/sling (spreader beam to crane)
3	Two-legged cable bridle/sling (spreader beam to lifting rail)
4	Lifting holes (each end of each lifting rail)
5	Lifting rail
6	Center of gravity (CG), offset approximately 25 mm (1 inch) to rear of magnet isocenter
7	Shackle (typically 4 locations)

**3. NOTE**

See [Step 15](#) in [2.7 Removing the shipping crate on page 22](#) for the procedure on examining witness marks before lifting with the orange rails. Attach the rigging to the lifting cables/slings at each end of the magnet.

**NOTE**

Wire rope is recommended for better length match and stretch control.

4. Attach the bridle slings to the magnet lifting rails with 25 mm (1.0 inch) pin shackles.
5. When beginning to lift the magnet, if it does not remain close to level, carefully lower the magnet and adjust the lifting configuration, and then lift the magnet again.
6. Smoothly move the magnet to the desired location, and carefully lower so it rests on a flat surface.

## 2.10 Lifting the magnet with a crane through the opening in the exterior wall

### Safety



#### **WARNING**

##### POTENTIAL SERIOUS INJURIES

Moving a magnet through a raised opening in an exterior wall can result in serious injuries and magnet/equipment damage.

Do the following before moving the magnet:

- Make sure a complete walk-through of the crane lift process was done prior to the actual event to make sure all process details are covered.
- Make sure all necessary equipment is on-site and inspected for safety and load ratings.
- Make sure all necessary personnel are trained and ready.
- Make sure that the entire area where lifting will occur is free of obstructions and unauthorized personnel.
- Make sure the surface where the magnet will be put after lifting is flat.
- Do not crane lift a magnet during dangerous weather conditions.



#### **WARNING**

##### POTENTIAL INJURY HAZARDS

Improper lifting of the magnet may be hazardous to personnel and can result in damage to the magnet and equipment.

Make sure that the entire area where lifting will occur is free of obstructions and unauthorized personnel.

Make sure that the surface where the magnet will be put after lifting is flat.

#### **NOTICE**

##### EQUIPMENT DAMAGE RISK

Improper transportation can result in expensive internal damage to the magnet.

Avoid sudden jolts. Lift/move/lower the magnet smoothly. Do not allow the magnet to bump or hit anything forcefully.

Avoid tilting the magnet more than the maximum tilt (30° from the horizontal level).

Do not apply any force to the magnet enclosures.

Do not crane lift a magnet that is on a pallet or inside a cage or crate.

Crane lifting can only be done using the magnet lifting rails, which are not accessible while the magnet is inside a cage or crate.

**Safety****NOTICE****EQUIPMENT DAMAGE RISK**

Improper crane transportation can result in damage to the magnet.

Do not crane lift crated/palleted magnets. Crated/palleted magnets must be handled in conformance with the other sections in [Chapter 2 Unloading and moving the magnet on page 13](#) of this manual.

Only a rigger should unload and move the magnet.

**NOTE**

The rigger is responsible for actual equipment/procedures used to lift and move a magnet into the customer facility, including through a raised opening in an exterior wall. The following procedures are guidelines only. It is the responsibility of the rigger to safely move the magnet into the facility.

1. Make sure that the opening is at least 2439 mm (96 inches) wide and 2591 mm (102 inches) tall, minimum. The magnet should pass through the opening side first without hitting the opening.

**NOTE**

A larger opening will make both the operation easier and accidental magnet damage less likely.

2. Position the hook of a crane and spreader beam (if used), which meet the specifications stated in section [2.2 Equipment requirements on page 17](#), centrally over the magnet to ensure a vertical lifting force on the lifting cables/slings (see [Figure 2-14 Crane lift configuration, magnet side view \(left\) and front view \(right\) on page 34](#)). If a spreader beam is not used, make sure that the strap length and crane lifting height are long enough so that the straps do not contact any part of the magnet above the magnet lifting beam and the magnet can reach the desired height.

**NOTE**

Align the spreader beam parallel to the magnet bore.

3. Rig the magnet with chain hoists toward the building, lifting cables/slings away from the building and a spreader beam.

**NOTE**



See [Step 15 in 2.7 Removing the shipping crate on page 22](#) for the procedure on examining witness marks before lifting with the orange rails.

Attach lifting straps to both ends of the lifting rail to face toward the building.

5. When beginning to lift the magnet, if it does not remain close to level, carefully lower the magnet and adjust the lifting configuration and then lift the magnet again.
6. Smoothly move the magnet through the raised opening in the exterior wall, and carefully lower so it rests on a flat surface.



## Chapter 3 Magnet storage conditions, pending ramp

### 3.1 Connecting the magnet to the compressor

Safety	
	<p><b>WARNING</b></p> <p>POTENTIAL COLD BURN OR ASPHYXIATION HAZARD</p> <p>Gaseous helium (odorless, colorless gas) is discharged from the magnet venting activities, and can cause cold burns or asphyxiation.</p> <p>Wear protective clothing, nonabsorbent gloves, and goggles when venting the magnet. Do not position yourself on or near the venting region.</p>
	<p><b>WARNING</b></p> <p>ELECTRIC SHOCK</p> <p>Contact with connectors leading to an energized compressor can cause electrical shock.</p> <p>Disconnect input power to the compressor and follow LOTO procedures to make sure power is not supplied to the compressor.</p>
	<p><b>NOTICE</b></p> <p>EQUIPMENT DAMAGE RISK</p> <p>Improper operation/maintenance of equipment can result in equipment damage.</p> <p>For detailed information about the operation, function, and maintenance of the cold-head and compressor, refer to the appropriate cryocooler and/or compressor vendor technical operating manual (Vendor Manuals CD32ZZ-226, CD32ZZ-227, CD32ZZ-067, CD33ZZ-073, CD33ZZ-080, and others), available through the support documentation library at <a href="http://gehealthcare.com">gehealthcare.com</a> or your local GE Healthcare Service Representative.</p> <p>For detailed information about the operation, function, and maintenance of the Magnet Monitor, please refer to the appropriate technical operating manual (<i>Magmon3 Installation and Service Manual</i>, 5124576 or <i>Magnet Monitor 4 Operating and Service Manual</i>, 5804162), available through the support documentation library at <a href="http://gehealthcare.com">gehealthcare.com</a> or your local GE Healthcare Service Representative.</p>

This magnet has superconducting coils immersed in a liquid helium vessel that is surrounded by an insulating cryostat. Due to site readiness delay, sometimes it is necessary to store the magnet in its shipping configuration at a warehouse. During this storage period, the magnet cryocooler must be connected to the compressor and the Magnet Monitor system to maintain proper temperature and pressure, and minimize helium loss as well as risk for internal icing issues.

1. Make sure that the compressor supply static pressure is within the range for the site's compressor:

Option	Description
<b>F-50 helium compressor unit</b>	1.6 MPa to 1.65 MPa <b>Figure 3-1 F-50 helium compressor unit, supply pressure</b> 
<b>F50SH compressor unit</b>	1.6 MPa to 1.65 MPa <b>Figure 3-2 F50SH compressor unit, supply pressure</b> 

2. Make sure that the O-rings are in the coldhead supply and coldhead return line connectors.
3. Connect the cooling water for the compressor (or do a check of the connection, if already connected).
4. Make sure that the default running mode is internal. FE or warehouse staff must not change this.
5. Using two wrenches (one to hold the backside adapter connection, and one to tighten), connect the coldhead compressor lines in the following order:

#### NOTE

The hold wrench maintains the backside adapter connection, making gas leaks in the system less likely. Do not overtighten.

**Figure 3-3 Using two wrenches to tighten a connection**

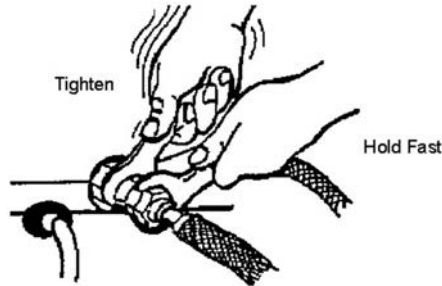

**NOTE**

Do not put any bending force on Aeroquip fittings while connecting/disconnecting helium flexlines. A bending force will create difficulty in the rapid engagement/disengagement required to prevent helium loss and system contamination. Support the gas lines when connecting/disconnecting them to the compressor.

- a. Attach the coldhead return line.
- b. Attach the coldhead supply line.
- c. Attach the coldhead power cable.

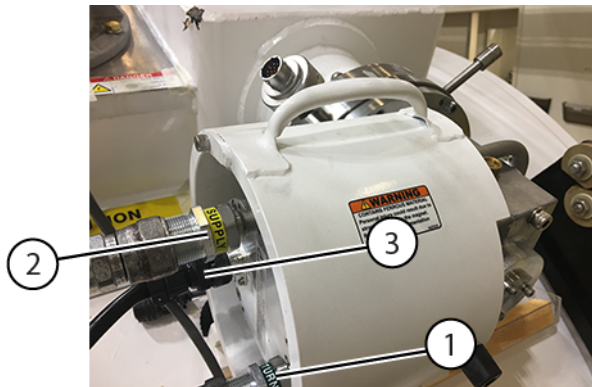
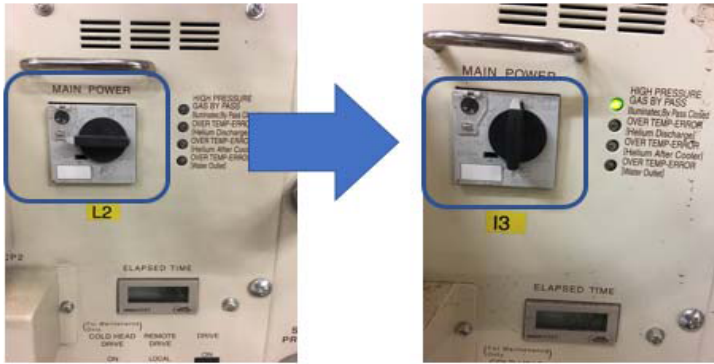

**Figure 3-4 Coldhead compressor connections**



1	First attachment - coldhead return
2	Second attachment - coldhead supply
3	Third attachment - coldhead power

6. Complete the following steps for the site's compressor:

Option	Description
<b>F-50 helium compressor unit</b>	To turn on the compressor, do the following: <ol style="list-style-type: none"> <li>1. For new compressor installations, make sure the input power voltage is connected to the compressor. If the input power voltage is 480V at 60Hz, no change on the voltage tap setting is required. Otherwise, set up the terminal wiring, located at the voltage tap area, per the input power voltage. Refer to vendor manuals for this procedure.</li> <li>2. Turn the compressor's main power switch to the ON position.</li> </ol>

Option	Description
	<p data-bbox="509 201 1032 233"><b>Figure 3-5 Compressor main power switch</b></p>  <p data-bbox="480 667 1060 699">3. Flip the compressor's drive switch to the ON position.</p> <p data-bbox="509 716 950 747"><b>Figure 3-6 Compressor drive switch</b></p>  <p data-bbox="472 1173 927 1205">To turn off the compressor, do the following:</p> <ol data-bbox="480 1213 1471 1381" style="list-style-type: none"> <li>1. When removing a unit from the compressor, do the above process in reverse order.</li> <li>2. Disconnect and lockout/tagout (LOTO) input power to the compressor. Use a digital voltmeter (DVM) or equivalent measuring device to make sure that no voltage is present.</li> <li>3. To prevent contamination of gas lines and the compressor, make sure the gas lines are removed immediately after power is disconnected.</li> </ol> <p data-bbox="509 1398 586 1430"><b>NOTE</b></p> <p data-bbox="561 1440 1369 1587">Do not put any bending force on Aeroquip fittings while connecting/disconnecting helium flexlines. A bending force will create difficulty in the rapid engagement/disengagement required to prevent helium loss and system contamination. Support the gas lines when connecting/disconnecting them to the compressor.</p>

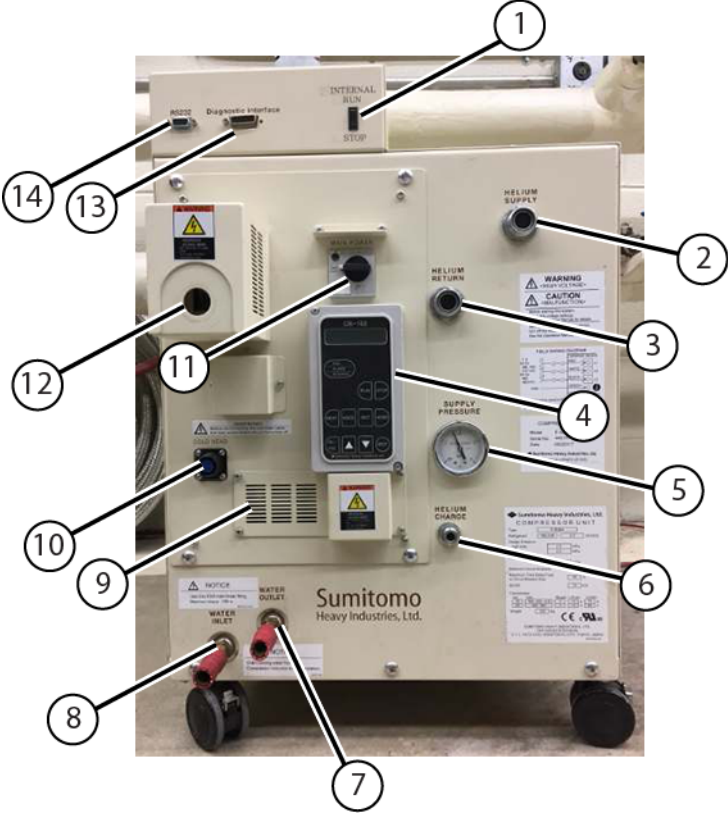
Option	Description
<p><b>F50SH compressor unit</b></p>	<p><b>Figure 3-7 F50SH compressor unit, front view</b></p>  <p>The image shows the front view of a Sumitomo F50SH compressor unit. It is a large, light-colored metal cabinet with various ports, gauges, and controls. Numbered callouts (1-14) identify the following components: 1. Run/Stop switch at the top center; 2. Helium supply port at the top right; 3. Helium return port below the supply; 4. Operation panel unit (OPU) in the center; 5. Pressure gauge (supply) to the right of the OPU; 6. Helium charge port at the bottom right; 7. Water outlet at the bottom center; 8. Water inlet at the bottom left; 9. Voltage tap on the left side; 10. Coldhead power line below the tap; 11. Main power switch below the tap; 12. Compressor power cable on the left; 13. Diagnostic interface (MM3) at the top left; 14. RS232C (MM4) port at the top left.</p>
1	Run/Stop switch
2	Helium supply
3	Helium return
4	Operation panel unit (OPU)
5	Pressure gauge (supply)
6	Helium charge port
7	Water outlet
8	Water inlet
9	Voltage tap
10	Coldhead power line
11	Main power switch
12	Compressor power cable
13	Diagnostic interface (MM3)
14	RS232C (MM4)
<p>To turn on the compressor, do the following:</p>	
<ol style="list-style-type: none"> <li>1. For new compressor installations, make sure the input power voltage is connected to the compressor. If the input power voltage is 480V at 60Hz, no change on the voltage tap setting is required. Otherwise, set up the terminal wiring, located at the voltage tap area, per the input power voltage. Refer to vendor manuals for this procedure.</li> </ol>	

Option	Description
	<p>2. Make sure the Run/Stop switch on the compressor's front panel is in the <b>RUN</b> position.</p> <p>3. Turn on main power switch, and wait 1 to 3 seconds for the compressor to start.</p> <p>4. Do a check for warnings or alarms.</p> <p><b>Important</b></p> <p>Whenever the compressor shows an alarm or warning, investigate the cause and solve the problem before resetting the alarm and running the compressor.</p> <p>To turn off the compressor, do the following:</p> <ol style="list-style-type: none"> <li>1. Turn off main power switch.</li> <li>2. Disconnect and lockout/tagout (LOTO) input power to the compressor. Use a digital voltmeter (DVM) or equivalent measuring device to make sure that no voltage is present.</li> <li>3. To prevent contamination of gas lines and the compressor, make sure the gas lines are removed immediately after power is disconnected.</li> </ol> <p><b>NOTE</b></p> <p>Do not put any bending force on Aeroquip fittings while connecting/disconnecting helium flexlines. A bending force will create difficulty in the rapid engagement/disengagement required to prevent helium loss and system contamination. Support the gas lines when connecting/disconnecting them to the compressor.</p>

## 3.2 Connecting the magnet monitoring connections

When connecting the cables, do not route the cables in a way that causes unnecessary strain or bending on the cables. Hand-tighten the screws on each connector; loose connections can cause reading errors.

1. Examine the cables used to monitor the magnet's pressure and helium level before connecting them to the magnet. Make sure that all pins are straight and almost level with the connector casing (for example, not pushed back). The cables should also not have any broken insulation. If you see any damage, get a new cable and replace the old one as soon as possible.

### NOTE

Each Magnet Monitor should have a dedicated cable set, which is firmly attached to the unit. Swapping cables between different magnet monitoring units can cause early failure of the connectors.

2. **(For F50SH)** Connect Cable, Run 850 MON J-2 to Compressor RS232 (5807125) from the Magnet Monitor to the compressor.
3. Attach the magnet pressure cable to the pressure transducer, as shown below.

**Figure 3-8 Attaching the pressure cable to the pressure transducer**



- Attach the helium level sensor cable into the LHe1 or LHe2 port (typical connection ports shown below).

**Figure 3-9 Typical instrumentation box ports (top) and cable connections (bottom)**

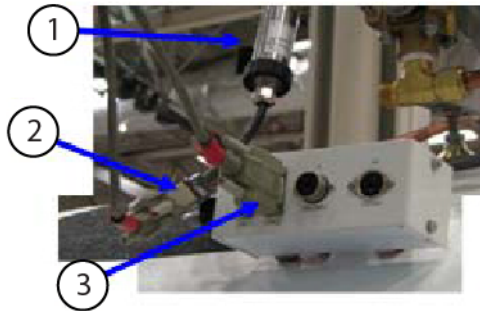

1	Pressure transducer
2	Pressure cable
3	Helium level sensor cable

- Close the V3 valve during storage to prevent helium loss from the 15.7 psia valve.

**Figure 3-10 V3 valve in the closed position**

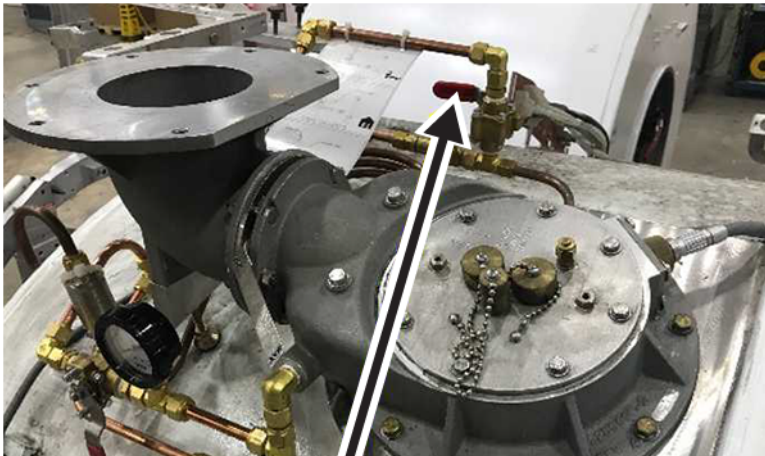

**NOTE**

The V3 valve must be reopened before the magnet resumes shipping.

## 3.3 Connecting the warehouse magnet monitoring connections

1. Turn on the Magnet Monitor and wait until it goes through its internal boot-up sequence. After that it will cycle between the date, helium level, and pressure.
2. Compare the pressure reading that appears on the Magnet Monitor display to the analog pressure gauge on the magnet. The gauge reading should be within  $\pm 0.5$  psig of the reading on the Magnet Monitor. If it is not, contact your local Online Center.

**Figure 3-11 Magnet analog pressure gauge**



3. Close the V3 valve during storage to prevent helium loss from the 15.7 psia valve.

**Figure 3-12 V3 valve in the closed position**

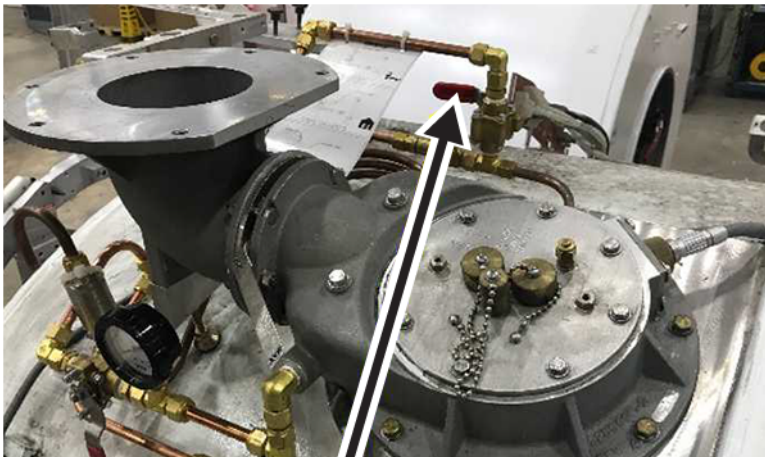

### NOTE

The V3 valve must be reopened before the magnet resumes shipping.

### 3.4 Monitoring the magnet

Using the Magnet Monitor front panel user interface, monitor the magnet pressure and helium level at least once per day to minimize loss of liquid helium and minimize internal icing situations.

The front panel of the Magnet Monitor unit is made up of the following elements:

- LEDs showing AC power, heater activity, and alarm activity
  - LCD display for user interaction
  - 16-button soft keypad
1. Press the **Home** button to change the display to usual operating mode. This mode shows the following information:

Screen	Display	
1	Date Software Revision	Title Number of Alarms
2	He Level x.xx%	
3	He Pressure x.xxx psig	

**Figure 3-13 Magnet Monitor front panel user interface, He Pressure (psig) (left) and He Level (%) (right)**

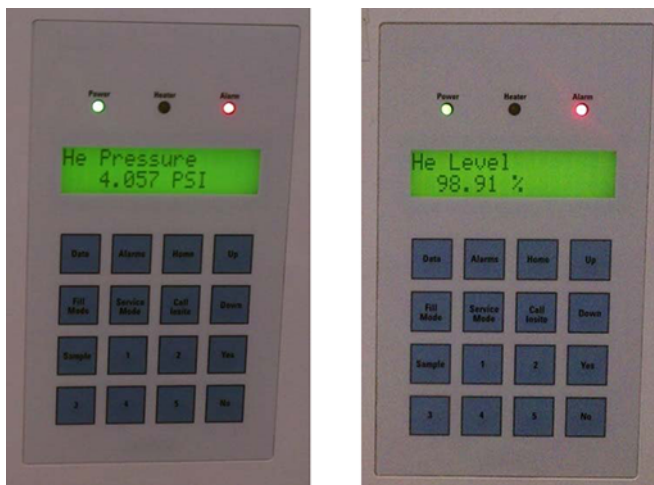

2. At the time of helium level monitoring, press the **Sample** button to initiate a helium level sample.

**NOTE**

It can take up to 90 seconds for the display to update and show the new level(s). Helium level requirements can vary according to purchase agreements. Work with your Logistics Team and/or Field Service Contact to determine helium level requirements.

3. Monitor helium pressure from the Home screen. If the system maintains a helium pressure above 5.0 psig ± 0.1 psig during normal operation, notify Service of the situation.

## 3.5 Monitoring the magnet at the warehouse

Upon magnet arrival, you need to check the magnet for typical values. If a magnet falls outside of any of these criteria, contact the local Online Center.

1. Make sure that the magnet arrival pressure is greater than 1.3 psi, depending on the site elevation.
2. The helium level should never drop more than 15% below the arrival level.
3. Make sure the pressure stabilizes at approximately 0.8 psi.

Page intentionally left blank

# Chapter 4 Doing in-transit service and magnet system checks

## 4.1 Preparing to do an in-transit helium refill

### Safety

#### NOTICE

##### EQUIPMENT DAMAGE RISK

Improper transportation can result in damage to the magnet.

Before you continue with an in-transit helium fill, make sure the shipping crate is removed from the magnet (see [2.7 Removing the shipping crate on page 22](#)).

In-transit service and magnet electrical checks must be done by qualified personnel only and in strict conformance with the *Doing a liquid helium fill* and *Doing a system leak test* procedures stated in the appropriate manual:

- *Magnet and Cryogen Manual for 1.5T R Series Magnets* (5928384-8EN)
- *MR Service Safety Manual* (5452735)

These documents are available through the support documentation library at [gehealthcare.com](http://gehealthcare.com) or your local GE Healthcare Service Representative.

The images below show in-transit plumbing configuration examples.

#### NOTE

Magnet images shown are representative. Actual magnet configuration may vary.

**Figure 4-1 Capped ports**

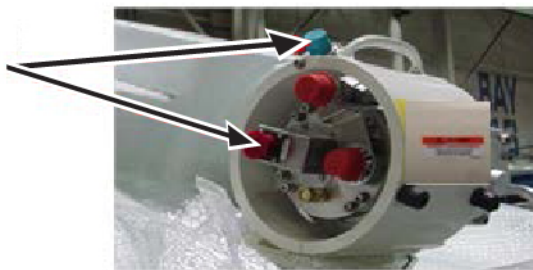

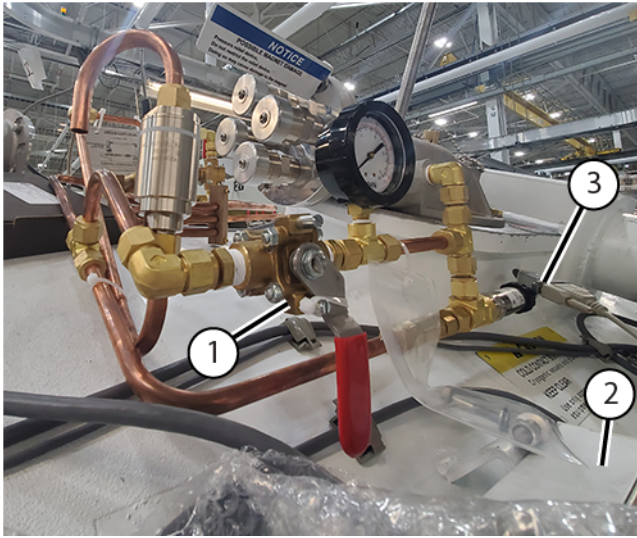
**Figure 4-2 In-transit plumbing configuration**

1	V2 valve tied
2	Cardboard box over instrumentation box
3	Pigtail secure to transducer

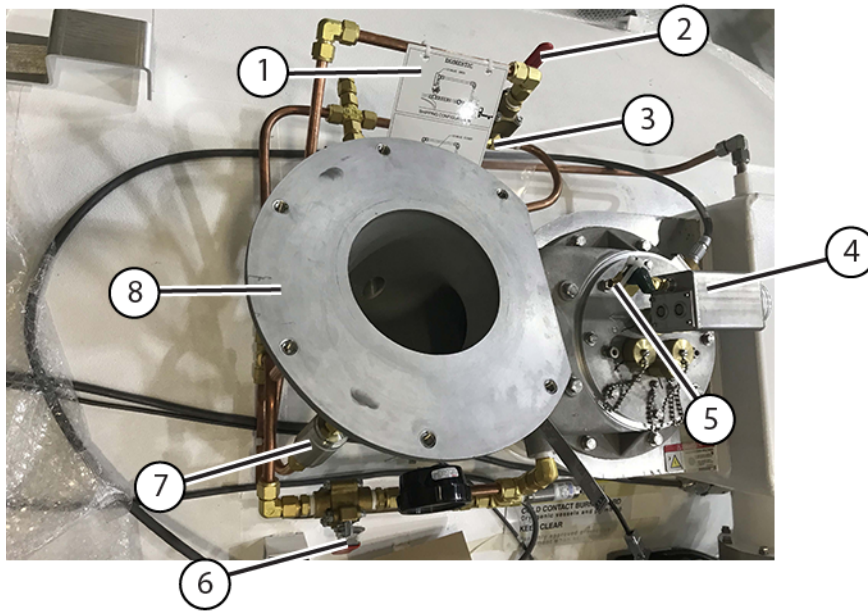
**Figure 4-3 Configuration of a domestically shipped magnet**

1	Shipping instruction placard
2	V3 valve <b>NOTE</b> The magnet arrives in the field with this valve open. The valve should be closed after the magnet is connected to the compressor unless otherwise specified in the <i>Magnet and Cryogen Manual</i> or a service note.
3	5.25 psi valve <b>NOTE</b> The magnet arrives in the field with this valve disconnected from the V3 T-adapter, blocked with caps on both ends, and tied together (international shipments only).
4	Shim lead assembly <b>NOTE</b> The magnet arrives in the field with the shim lead down. Refer to the shipping hose instruction placard for shim lead positioning during shipping, storage, and site installation.
5	Nupro valve
6	V2 valve
7	15.7 psia valve
8	Vent adapter

**Figure 4-4 Configuration of a magnet shipped by air or ocean**

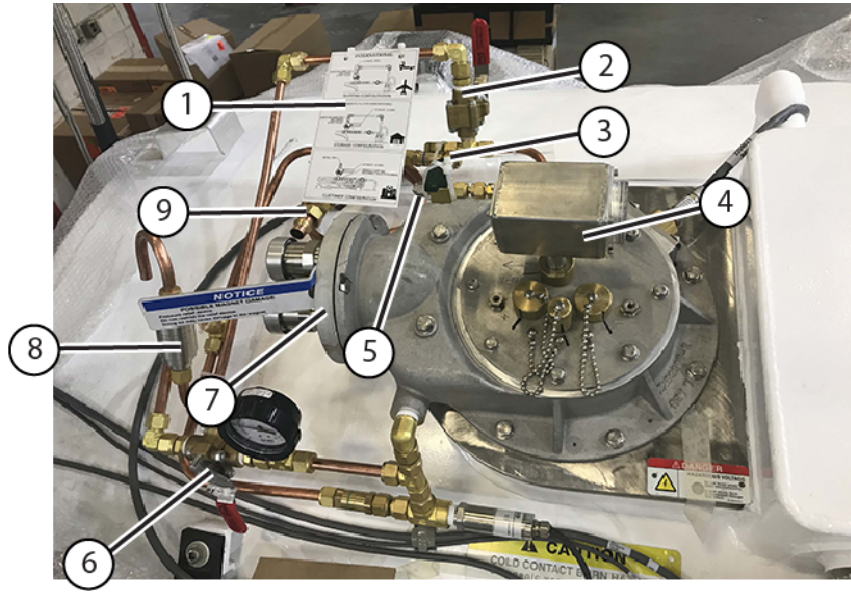

1	Shipping instruction placard
2	0.5 inch V3 fitting <b>NOTE</b> The magnet arrives in the field with the V3 valve open. The valve should be closed after the magnet is connected to the compressor unless otherwise specified in the <i>Magnet and Cryogen Manual</i> or a service note.
3	5.25 psi valve <b>NOTE</b> The magnet arrives in the field with this valve disconnected from the V3 T-adapter, blocked with caps on both ends, and tied together (international shipments only).
4	Shim lead assembly <b>NOTE</b> The magnet arrives in the field with the shim lead down. Refer to the shipping hose instruction placard for shim lead positioning during shipping, storage, and site installation.
5	Nupro valve
6	Blanking plate with 15 psig relief valves
7	V2 valve
8	15.7 psia valve
9	0.5 psig relief valve

**NOTICE****COMPONENT DAMAGE**

Thread tape has a negative effect on the leak tightness of compression fittings.

Do not apply thread tape to any compression threads on the new plumbing assembly.

Optionally, if you want a pressure measuring device for an in-transit liquid helium fill, you can connect a device to the Nupro valve output on the shim lead. The following steps explain how to reconnect the 5.25 psi valve, when to do the liquid helium fill, and how to disconnect the 5.25 psi valve again for international shipment after the liquid helium fill is complete.

**NOTE**

When the liquid helium fill is complete, you must disconnect the 5.25 psi valve for international shipment. For domestic transportation it can remain connected.

1. Complete the following substeps to raise the shim lead to the fully extracted position:
  - a. Loosen the shim lead compression fitting (the brass collar at the base of the shim lead).
  - b. Pull up firmly from the underside of the shim lead connector housing until the shim lead assembly unseats.
  - c. Pull the shim lead up all the way and turn the shim lead assembly to the Locked position.
  - d. Hand-tighten the shim lead compression fitting until it is helium leak tight.

**Figure 4-5 Raising the shim lead**

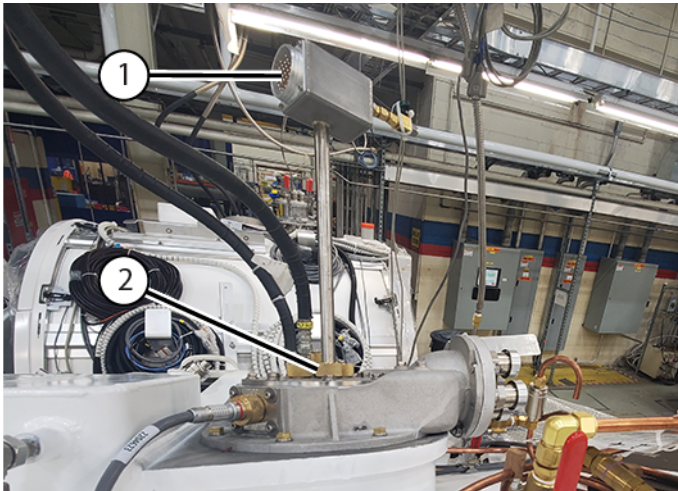

1	Shim lead assembly, extracted
2	Brass collar

2. Cut the zip tie holding the V3 valve in the open position.
3. Close the V3 valve.
4. Look at the pressure gauge and make sure that the magnet has positive pressure, > 0.5 psig.

- Cut the zip tie securing the 5.25 psi valve, and remove the caps from the T-adapter and 5.25 psi valve. Reconnect the 5.25 psi valve to the T-adapter.

**Figure 4-6 Reconnecting the 5.25 psi valve to the V3 valve**

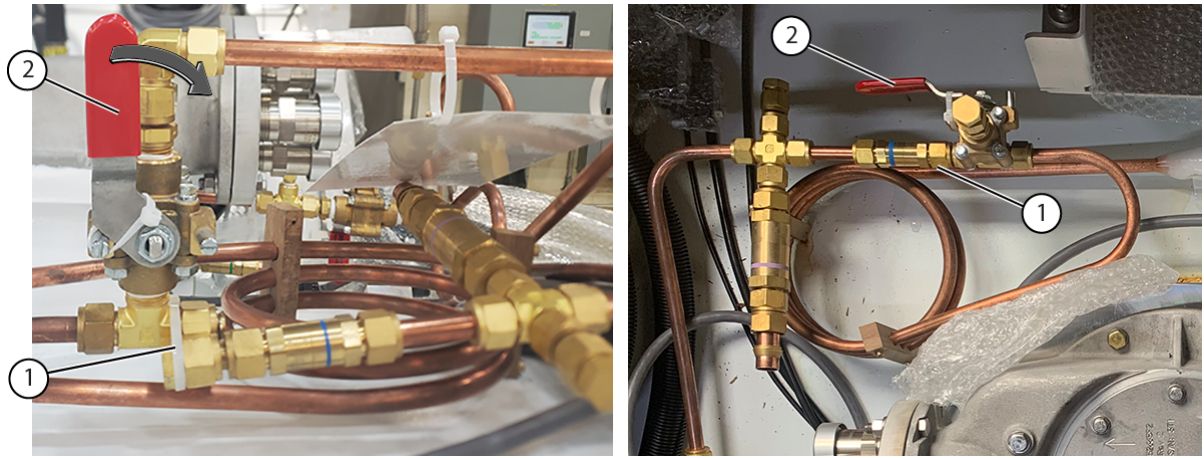

1	5.25 psi valve reconnection point
2	V3 valve, to be closed

- Attach a pressure gauge to the Nupro valve port. Make sure the Nupro valve is open.
- Do a liquid helium fill.

**NOTE**

For more information about doing a liquid helium fill, refer to the *Magnet and Cryogen Manual for 1.5T R Series Magnets (5928384-8EN)*.

**NOTE**

Once the liquid helium fill is complete, you must follow the remaining steps to reconnect the shipping hose to the magnet.

- Close the Nupro valve. Remove the pressure gauge from the Nupro valve port.
- Make sure the magnet pressure is below 0.5 psig.
- Disconnect the 5.25 psi valve from the V3 T-adapter. Replace the caps on the 5.25 psi valve and T-adapter (only required for international shipment).
- Fully open the V3 valve and zip tie the V3 valve in the open position.
- Lower the shim lead into the Sav-Con. Tighten the brass collar to secure the shim lead in position.

**NOTE**

Pressure may rise significantly from dropping the warm shim lead. This may cause the magnet to start venting out of the 15.7 psia valve on the plumbing assembly. This is expected.

- Do a leak check on all pipe fittings connecting the shipping hose to the plumbing assembly and the shim lead. If there are leaks, wrench-tighten the connections that are leaking a quarter turn at a time and then re-check.

## 4.2 Doing a magnet system check

### Safety

#### NOTICE

##### EQUIPMENT DAMAGE RISK

Improper transportation can result in damage to the magnet.

In-transit service and magnet electrical checks must be done by qualified personnel only, after the magnet is sited and in strict conformance with the *Doing a liquid helium fill* procedure stated in the appropriate manual:

- *Magnet and Cryogen Manual for 1.5T R Series Magnets* (5928384-8EN)
- *MR Service Safety Manual* (5452735)

These documents are available through the support documentation library at [gehealthcare.com](http://gehealthcare.com) or your local GE Healthcare Service Representative.

#### NOTE

Magnet system checks are a physical inspection done by GE Service.

1. Locate the Pre-Delivery Information Package shipped with the magnet. It contains the Bill of Material for the magnet system delivered.
2. Make sure that all boxes indicated on the Bill of Material are included.
3. Make sure that the contents of each box matches its packing list when the boxes are brought into the MR site.
4. Inspect the magnet for physical damage and icing/condensation on the body, and do one of the following:

#### NOTE

Because of the higher boil-off and helium gas flow through the vertical penetration on all shipments, some frost on the vertical penetration may be normal during periods when the coldhead has been shut off.

- If no problems are found, unload the magnet.
  - If there is damage, report the damage in conformance with the procedure [1.2 Examining packages for damage in transportation on page 7](#). Report all problems found to the regional Magnet & Cryogenics (MAC) Team Leader.
5. If there is icing or condensation on the exterior or the bore of the magnet, check the liquid helium level before unloading. Refer to the Installation and Adjustment section's "Installing the Magnet Monitor" procedure in the *Magnet and Cryogen Manual for 1.5T R Series Magnets* (5928384-8EN).

#### NOTE

If the magnet has been sitting for a period of time with the coldhead inoperative, the magnet may be depleted of cryogens. Contact the logistics or field service team for further directions.

Page intentionally left blank

## Chapter 5 Preparing the scan room

### Safety



#### CAUTION

##### HEAVY OBJECT

Improper lifting of non-SV damping mats can result in personal injury.

Each surface mounted non-SV vibroacoustic damping mat weighs ~105 kg (250 lbs). Do not lift or move mats alone without mechanical assistance.

Handling of vibroacoustic damping mats must be done by riggers, not GE service personnel.

1. Remove any debris from the magnet room floor where the mats will be positioned.
2. Make sure that there are no RF seams under the vibroacoustic damping mats.
3. Move the vibroacoustic damping mats to the MR suite.

#### NOTE

The vibroacoustic damping mats may arrive in a cold state preventing compression. Put the vibroacoustic damping mats in the magnet room prior to moving the magnet to the MR suite to let their temperature stabilize.

4. Make sure that markings are present on the magnet room floor where the vibroacoustic damping mats will be located. Markings should be in accordance to the specifications stated in the appropriate *Preinstallation Manual* (see [Appendix B Preinstallation Manual reference on page 107](#)).

Page intentionally left blank

## Chapter 6 Installing a nonseismic vibroacoustic damping mat and leveling the magnet

Safety	
	<p><b>CAUTION</b></p> <p><b>HEAVY OBJECT</b></p> <p>Improper lifting of non-SV damping mats can result in personal injury.</p> <p>Each surface mounted non-SV vibroacoustic damping mat weighs ~105 kg (250 lbs). Do not lift or move mats alone without mechanical assistance.</p>
	<p><b>NOTICE</b></p> <p><b>EQUIPMENT DAMAGE RISK</b></p> <p>Improper damping mat installation can result in damage to the magnet.</p> <p>Tasks in this section must be completed by riggers, not GE Service Personnel. The surface mounted vibroacoustic damping mats must be installed on the floor before moving the magnet into the magnet room.</p>

### 6.1 Equipment overview

Tools and test equipment			
Item	Quantity	Part number	Manufacturer
305 mm (1 foot) Bubble Level in good condition; no sharp edges, corners, dents, bumps, cracks or loose bubble vials.	1	-	-
1000 mm (3 foot) Bubble Level in good condition; no sharp edges, corners, dents, bumps, cracks or loose bubble vials.	1	-	-
Tape Measure	1	-	-
Magnet Leveling Kit (contents detailed in table below)	1	46-260888G4	-
SV Vibroacoustic Damping Kit	1 of these kits	M50002LP	-
Vibroacoustic Damping Option A		M1060MA	-

<b>Magnet Leveling Kit (46-260888G4)</b>			
<b>Item</b>	<b>Quantity</b>	<b>Part number</b>	<b>Manufacturer</b>
Leveling Shim, 1.57 mm (0.062 inches) thick	12	2213945	-
Leveling Shim, 0.51 mm (0.020 inches) thick	8	2213945-2	-
Contact Shim, 152 x 152 x 0.51 mm (6.00 x 6.00 x 0.20 inches thick)	24	2180016	-
Contact Shim, 152 x 152 x 0.81 mm (6.00 x 6.00 x 0.32 inches thick)	16	2180016-2	-
Contact Shim, 152 x 152 x 1.0 mm (6.00 x 6.00 x 0.40 inches thick)	8	2180016-3	-
Contact Shim, 152 x 152 x 1.6 mm (6.00 x 6.00 x 0.63 inches thick)	4	2180016-4	-

<b>Required conditions</b>
Magnet and dock installation and placement are critical to image quality and hardware reliability.
The magnet must be installed level with the isocenter to the specifications of the magnet height listed in the <a href="#">6.8 Leveling a magnet on page 73</a> procedure.

## 6.2 Positioning a non-SV nonseismic mounted vibroacoustic damping mat

1. Make sure that the vibroacoustic kit contains the parts listed in the following table.

**Table 6-1 Vibroacoustic damping mat kit (M1060MA)**

<b>Quantity</b>	<b>Part number</b>	<b>Description</b>
1 pair	5122574	Vibroacoustic Damping Mat, one Labeled FRONT and one Labeled REAR
4	5476688	76.8 x 76.8 mm (3 x 3 inch) Aluminum Washers*
4	5477278	0.75-10 x 4 inch Stainless Steel Studs*
4	46-260943P6	0.75-10 Stainless Steel Nuts*
4	46-252635P14	Washer, Plain, 0.75 x 0.100 THK, Stainless Steel Flat Washers*
4	5394873	Sleeve, for M20 Seismic Anchor

\*For anchoring the magnet to surface-mounted vibroacoustic damping mats.

2. Put the vibroacoustic damping mats on the floor, in the appropriate location where the magnet will be set.

### **NOTE**

The M1060MA vibroacoustic damping mats consist of two identical plates.

**Figure 6-1 Surface mounted non-SV vibroacoustic damping mats****NOTE**

The 3 x 3 washer, SS stud, SS nut, and flat washer pointed out above is shown on the mat for illustration purposes only. It needs to be positioned inside the magnet foot to secure the magnet foot to the mat.

- Center the vibroacoustic mats based on the magnet geometric isocenter or the 8-inch quench vent location.

## 6.3 Positioning a nonseismic mounted SV vibroacoustic damping mat

- Make sure that the SV vibroacoustic kit contains the parts listed in the following table.

**Table 6-2 SV vibroacoustic damping mat kit (M50002LP)**

Quantity	Part number	Description
2	5420414	Vibro pad
2	5420414-2	Vibro pad

**NOTE**

The kit consists of two sets of two identical plates.

- Identify the magnet geometric isocenter based on the vent stack location as shown in the magnet footprint below.

**Figure 6-2 SV vibroacoustic mat placement (M50002LP)**

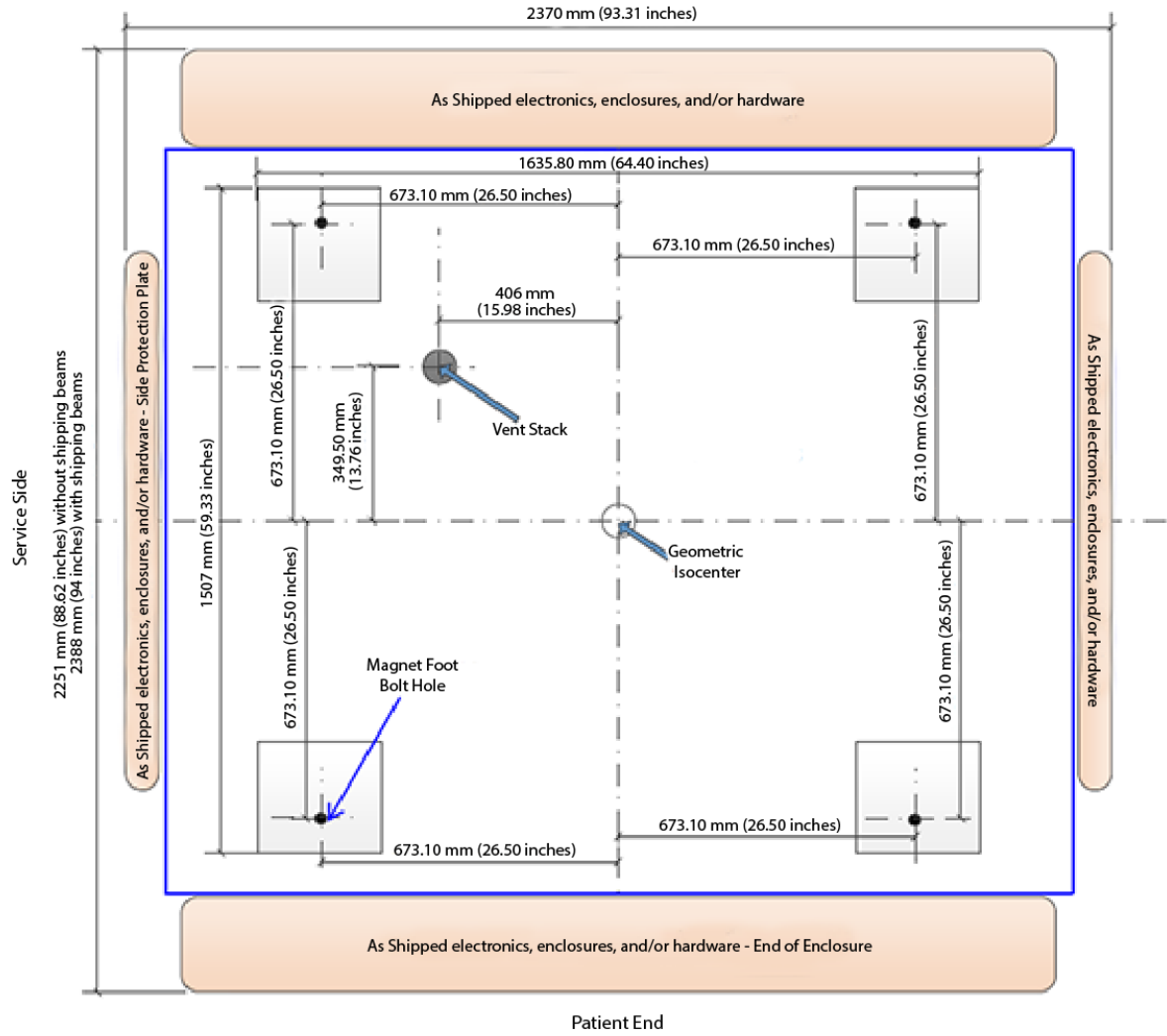

- Put the SV vibroacoustic mats where magnet feet will be located, spaced as shown in the previous and next illustrations.

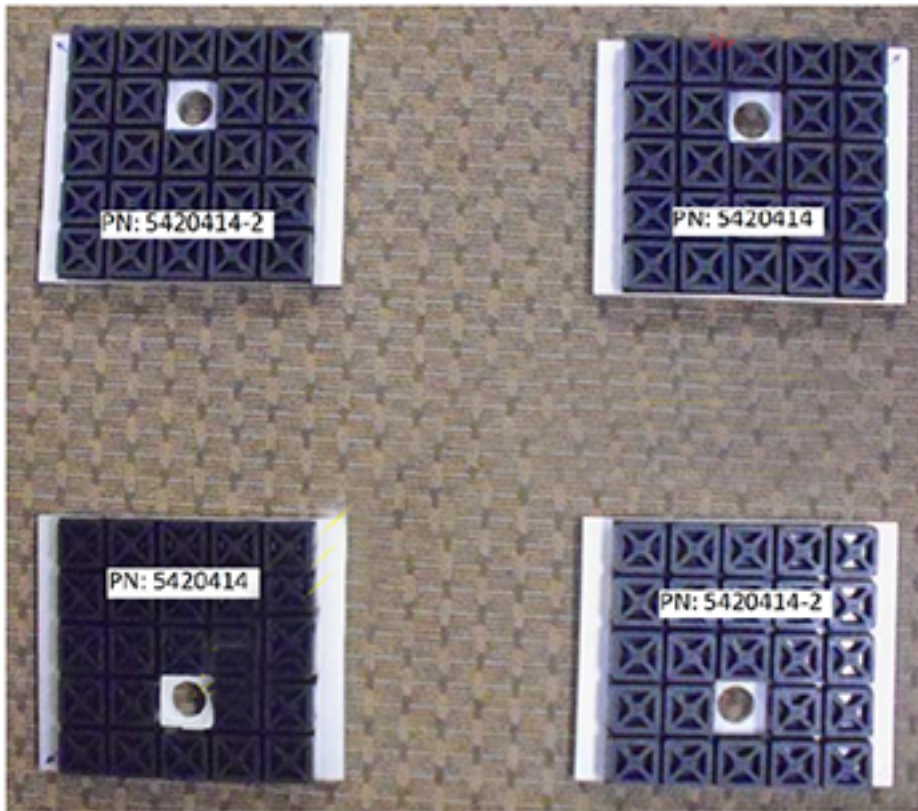

**Figure 6-3 SV vibroacoustic mats, magnet rear/service (top) and magnet front/patient (bottom)**

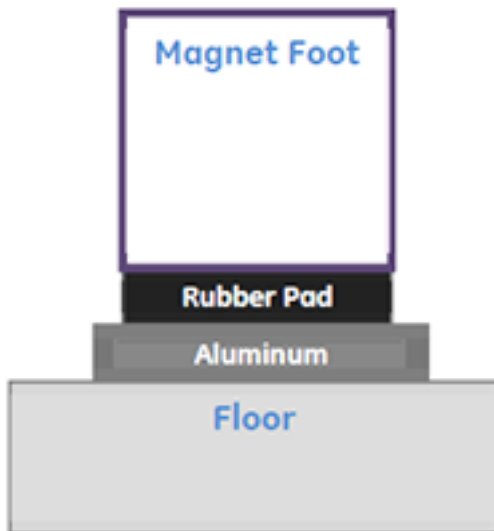

- Position the mats so that the rubber dampener will face up against the magnet foot and the aluminum plate faces down against the floor.



## 6.4 Preparing to move the magnet

Safety	
	<p><b>DANGER</b></p> <p>POTENTIAL ASPHYXIATION HAZARD</p> <p>Loss of magnet vacuum will result in the rapid expulsion of helium gas, which can cause asphyxiation in enclosed areas.</p> <p>Make sure that hospital personnel are aware of this situation prior to the magnet being moved within the enclosed areas. Use extreme caution and do not contact or damage the vacuum vessel during magnet transit or siting.</p>
	<p><b>WARNING</b></p> <p>POTENTIAL INJURY HAZARD</p> <p>Moving the magnet improperly will cause personal injury or magnet damage.</p> <p>See <a href="#">Chapter 2 Unloading and moving the magnet on page 13</a> before moving the magnet using a forklift or crane.</p>
	<p><b>NOTICE</b></p> <p>EQUIPMENT DAMAGE RISK</p> <p>Improper transportation can result in damage to the magnet.</p> <p>Tasks in this section are to be done by riggers, not by GE HealthCare Personnel.</p> <p>Do not apply any force to the magnet's enclosures.</p> <p>Any floor anchors that are used to move the magnet must not penetrate the RF shield.</p> <p>Magnet and dock installation and placement are critical to image quality and hardware reliability. The magnet must be installed level with the isocenter to the specifications listed in this chapter.</p>
	<p><b>NOTICE</b></p> <p>EQUIPMENT DAMAGE RISK</p> <p>Improper magnet height can result in damage to the magnet if you try to move the magnet to a low ceiling area.</p> <p>The 1-inch aluminum spacer plate can be removed from each magnet foot. Refer to the steps in this procedure to remove the aluminum spacers.</p> <p>Do not remove the 1-inch spacers until you are ready to put the magnet on the vibroacoustic pads. Contact the Install Base Leader at GEHC Florence for further instruction.</p>

After the magnet is moved to the building using a crane or forklift (see [Chapter 2 Unloading and moving the magnet on page 13](#)), it needs to be moved to the magnet room. There are many methods to help move the magnet, including the use of a motorized tow vehicle, a come-along, or a chain jack. When you are moving the magnet, make sure that you are moving it in a smooth, controlled manner.

**NOTE**

Remove the lifting rails and bubble wrap at any point forward when the process allows, and you are done using the rails. When removing the bubble wrap, do not nick or cut any electrical cables.

1. Optionally, roller dollies are recommended for moving the magnet inside a building. If you use roller dollies, put steel floor plates along the magnet delivery route.

**Figure 6-4 Magnet on roller dollies**

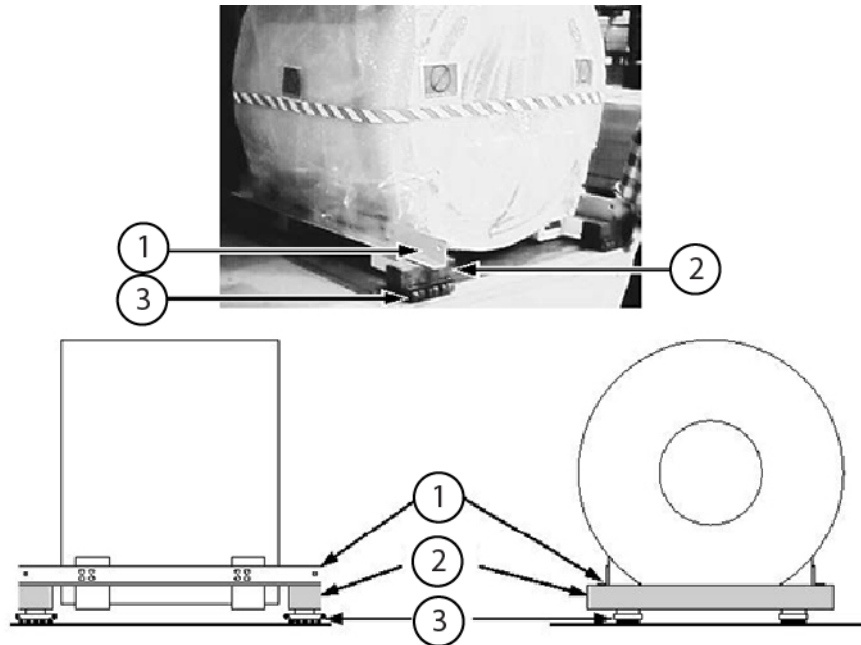

1	Lifting rails
2	100 mm x 150 mm (4 inch x 6 inch) wood beams
3	Roller dollies

2. Have the rigger make sure that walls, floors, and so on along the transportation route are protected from potential damage.
3. Attach any cables, chains, or straps used for moving the magnet to the orange lifting rails.
4. Make sure that the magnet front-rear orientation is relative to the magnet room's front and rear.
5. Do a check of all clearances along the route that the magnet will move to get to the magnet room. Compare those clearances with the appropriate illustration below.

**NOTE**

Magnet image is shown for reference and may differ from the configuration shipped. The dimensions indicated are for the condition as shipped.

**NOTE**

Dimensions referenced are worst-case scenarios.

**Figure 6-5 Clearance dimensions, magnet patient end as-shipped condition**

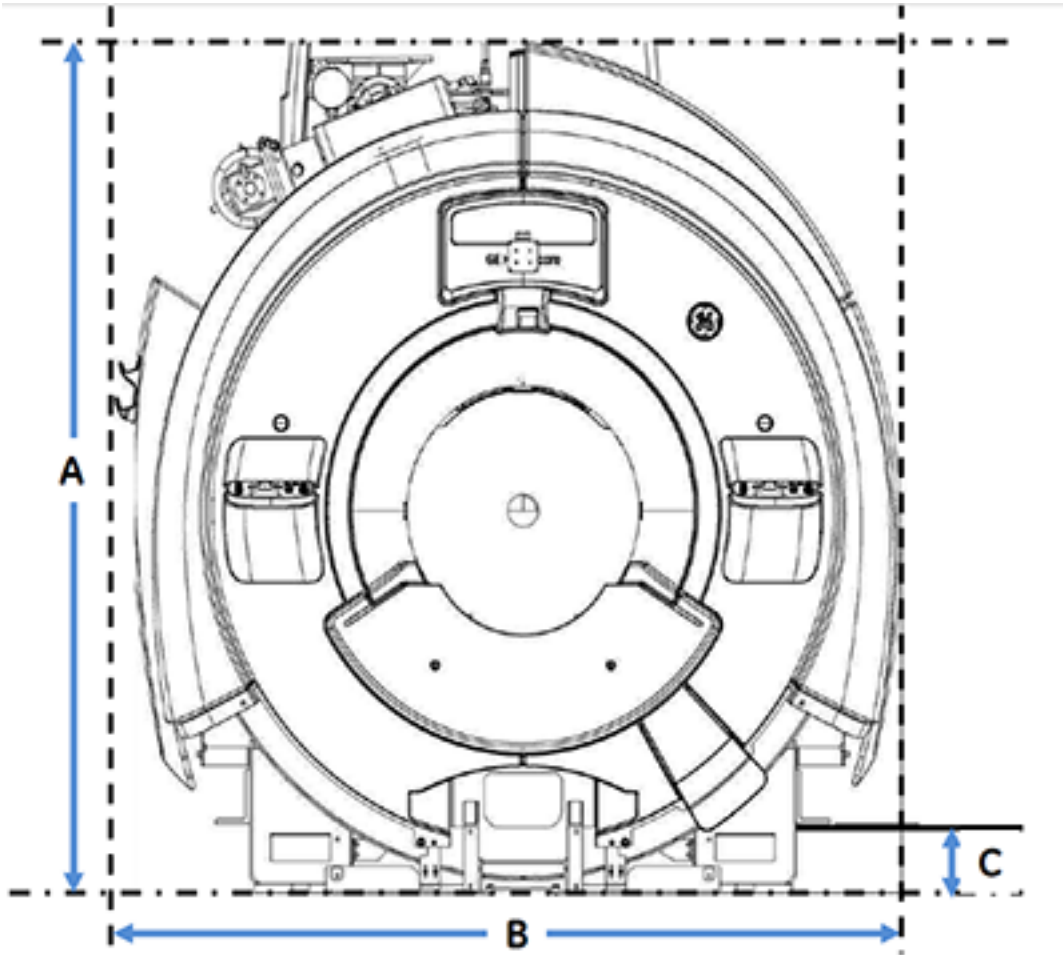

A	2383 mm (93.83 inches)
B	2370 mm (93.31 inches)
C	193 mm (7.60 inches)

**Figure 6-6 Clearance dimensions, magnet service side as-shipped condition**

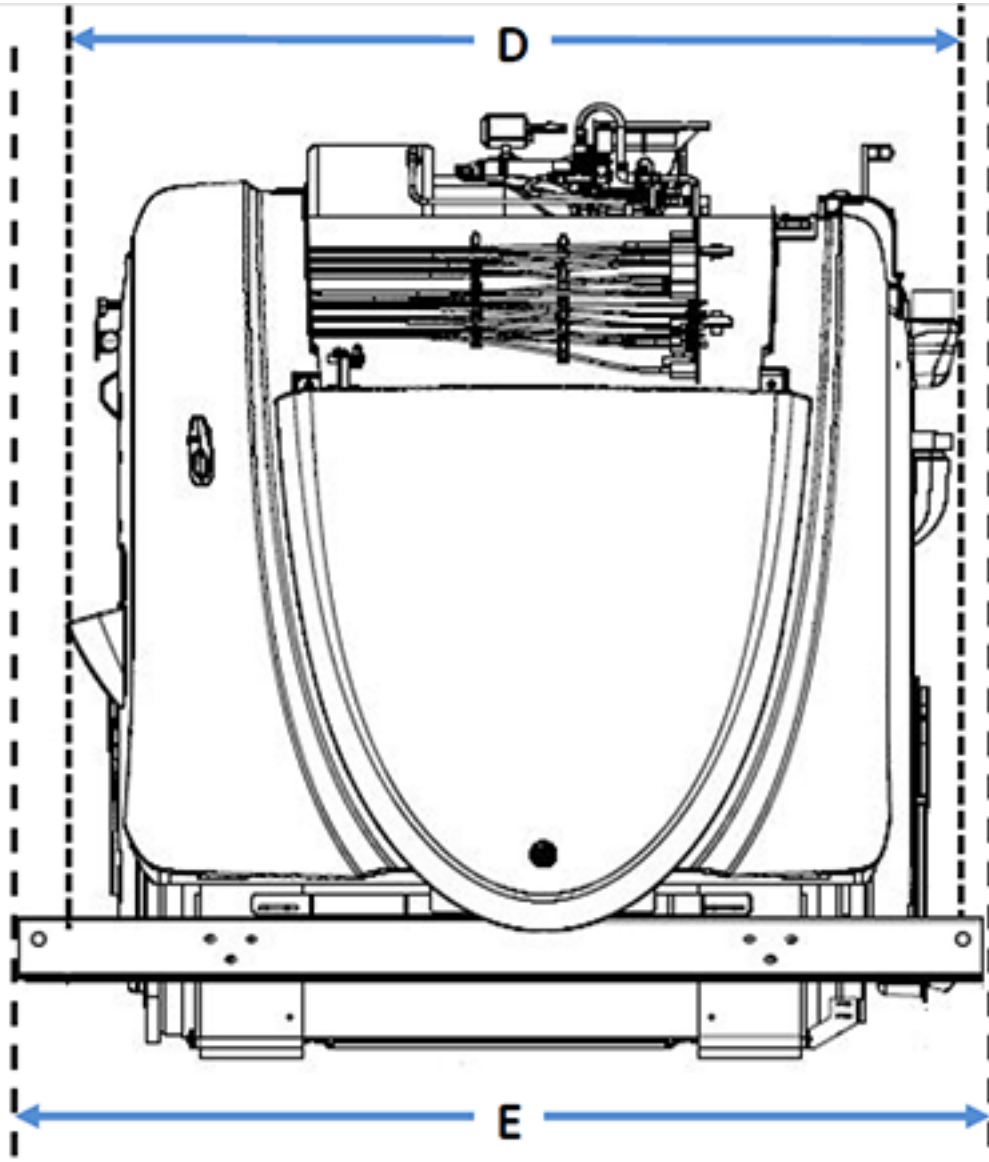

D	2251 mm (88.62 inches)
E	2388 mm (94.00 inches)

6. Compare the dimensions of the magnet on the moving fixtures being used with the clearances measured along the magnet delivery route. The height can be reduced by putting the moving fixtures directly under the lifting rails.

## 6.5 Moving the magnet into the MR suite

Safety	
	<p><b>CAUTION</b></p> <p>POTENTIAL PERSONAL INJURY</p> <p>Uneven jacking of the magnet's corners could result in the magnet shifting on the jacks, which may lead to personal injury or magnet damage.</p> <p>Keep the magnet level at all times during any jacking operation.</p>
	<p><b>NOTICE</b></p> <p>EQUIPMENT DAMAGE RISK</p> <p>Improper loads on enclosure cover parts can result in damage to the enclosure.</p> <p>Do not apply any loads to enclosure cover parts.</p> <p>Do not allow straps, cables, or chains to scrape enclosure cover parts.</p>

1. If raising the magnet is required, the lifting portion of the jack must be fully below the lifting rails.
2. Avoid tilting or rotating the magnet while moving it into the MR suite.
3. From the magnet room entrance to the magnet's final position, put steel floor plates as needed to protect the magnet room floor. The rigger must take actions necessary to ensure that walls, floors, and so on along the transportation route/path are protected from potential damage.
4. Move the magnet to the magnet room. (If using a motorized tow vehicle, attach cables, chains, or straps to the magnet's lifting rails with shackles.)
5. Center the magnet in the magnet room based on the magnet geometric isocenter or the 8-inch quench vent location.
6. Make sure that there is adequate distance between the service side of the magnet and the magnet room wall as specified in the appropriate *Preinstallation Manual* (see [Appendix B Preinstallation Manual reference on page 107](#)).
7. Make sure there is clearance for the service ladder.

## 6.6 Lowering the magnet into position

1. Cut open and remove enough of the bubble wrap to allow access to the feet and for leveling operations.

### NOTE

When cutting off the bubble wrap, do not nick or cut any electrical cables.

2. Move the magnet to align the holes in the magnet feet, based on the type of vibroacoustic mat:

Vibroacoustic mat type	Procedure
<b>SV</b>	<ol style="list-style-type: none"> <li>1. Align the holes in the magnet feet to the magnet feet bolt holes in the vibroacoustic damping mats or the magnet anchors.</li> <li>2. Make sure that the four holes, one per each magnet foot, align centered <math>\pm 3</math> mm (<math>\pm 0.125</math> inches) over the anchor stud holes in the vibroacoustic damping mats or the magnet anchors.</li> </ol>
<b>Non-SV</b>	<ol style="list-style-type: none"> <li>1. Align the holes in the magnet feet to the magnet feet bolt holes in the vibroacoustic damping mats.</li> <li>2. Make sure that the four holes, one per each magnet foot, align centered <math>\pm 3</math> mm (<math>\pm 0.125</math> inches) over the magnet feet bolt holes in the vibroacoustic damping mats.</li> </ol>

3. Jack the magnet up sufficiently at the two lifting rails (four corners), and remove the moving fixtures.
4. To remove the 1-inch aluminum spacer from each magnet foot, complete the following substeps:
  - a. Find a  $\frac{3}{4}$  inch (19 mm) wrench.
  - b. Remove the two  $\frac{3}{8}$  inch hex-head bolts that secure the 25 mm (1 inch) aluminum spacer to each foot.
  - c. Remove and store the aluminum spacers on-site.

**Figure 6-7 Bolts securing aluminum spacer**

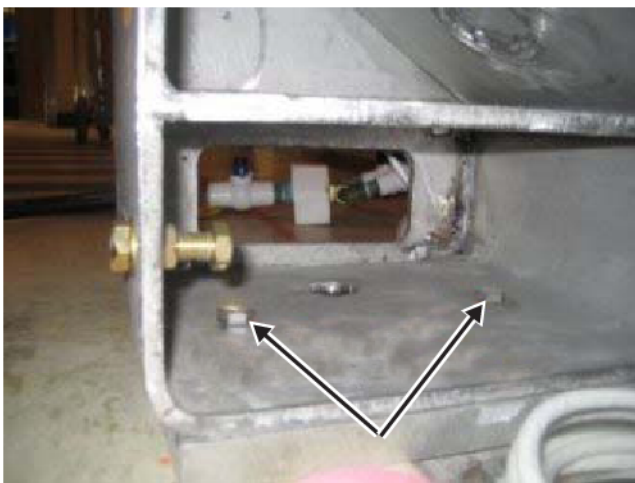

- Slowly lower the magnet onto the vibroacoustic mats.

**Figure 6-8 Moving the magnet onto surface mounted non-SV vibroacoustic damping mats**



1	Floor protection
2	Vibroacoustic damping mat
3	Magnet anchor holes
4	Magnet front

- Release pressure simultaneously in both jacks on one end of the magnet until that end is 25 to 50 mm (1 to 2 inches) lower than the opposite end.
- Simultaneously lower both jacks on the other end 25 to 50 mm (1 to 2 inches).
- Repeat lowering the magnet end to end until all feet are on the vibroacoustic mats.

**Figure 6-9 Magnet installed on surface mounted non-SV vibroacoustic damping mats**



## 6.7 Adding leveling shims

Review this section before you begin to level the magnet. If, while leveling the magnet, you need to insert shims under a magnet foot to achieve correct leveling, this section provides instructions for raising any one of the four magnet feet and properly placing shims with respect to the specific vibroacoustic mat.

1. Use a jack to raise the lowest magnet foot.
2. Insert the appropriate thickness of aluminum shim plates under the low magnet foot.

**Table 6-3 Leveling shim placement**

	<b>SV</b>	<b>Non-SV</b>
<b>Vibroacoustic mat (VM)</b>	M50002LP	M1060MA
<b>Leveling shim placement</b>	On the floor, beneath the VM aluminum plate	Between the magnet foot and the stainless steel surface of the VM
<b>Magnet to vibroacoustic mat anchor</b>	Anchoring not required	Center stud
<b>Remove 1-inch Al spacer from each foot?</b>	Yes, before final positioning in MR suite	

- Put the shims in position, based on the type of vibroacoustic mat:

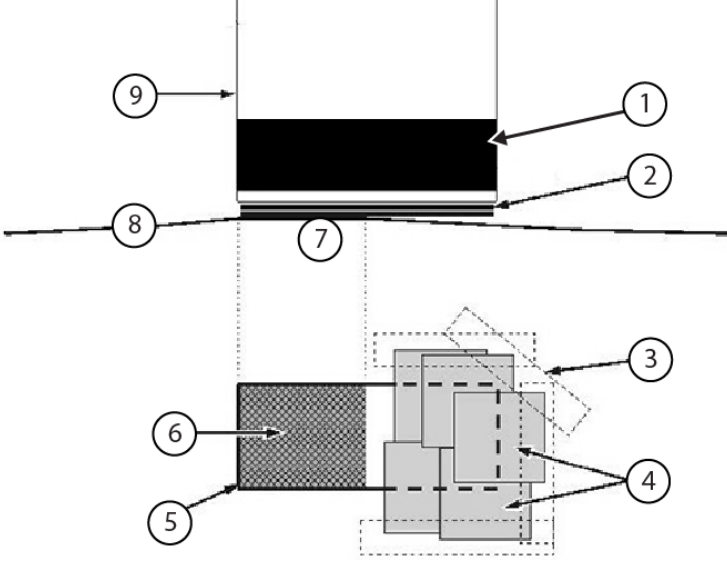
Vibroacoustic mat type	Procedure																		
SV	<p>Put the shims on the floor, under the vibroacoustic mat's aluminum plate.</p> <p><b>Figure 6-10 Shim arrangement for gap fill</b></p>  <table border="1" data-bbox="446 997 1469 1438"> <tr> <td>1</td> <td>Vibroacoustic mat</td> </tr> <tr> <td>2</td> <td>Leveling shims (to make large adjustments to magnet height)</td> </tr> <tr> <td>3</td> <td>Duct tape covering shim edges</td> </tr> <tr> <td>4</td> <td>Contact shims (to make small adjustments in magnet height and to compensate for small localized variations in floor levelness)</td> </tr> <tr> <td>5</td> <td>Outline of magnet foot</td> </tr> <tr> <td>6</td> <td>Foot contact with floor</td> </tr> <tr> <td>7</td> <td>"High" spot</td> </tr> <tr> <td>8</td> <td>Uneven floor surface</td> </tr> <tr> <td>9</td> <td>Magnet foot</td> </tr> </table>	1	Vibroacoustic mat	2	Leveling shims (to make large adjustments to magnet height)	3	Duct tape covering shim edges	4	Contact shims (to make small adjustments in magnet height and to compensate for small localized variations in floor levelness)	5	Outline of magnet foot	6	Foot contact with floor	7	"High" spot	8	Uneven floor surface	9	Magnet foot
1	Vibroacoustic mat																		
2	Leveling shims (to make large adjustments to magnet height)																		
3	Duct tape covering shim edges																		
4	Contact shims (to make small adjustments in magnet height and to compensate for small localized variations in floor levelness)																		
5	Outline of magnet foot																		
6	Foot contact with floor																		
7	"High" spot																		
8	Uneven floor surface																		
9	Magnet foot																		

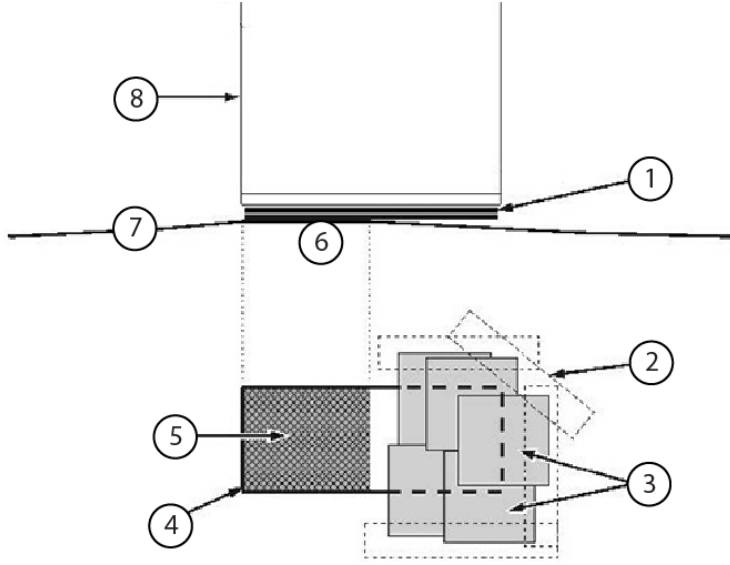
Vibro-acoustic mat type	Procedure																
Non-SV	<p data-bbox="443 258 1438 289">Put the shims between the magnet foot and the stainless steel surface of the vibroacoustic mat.</p> <p data-bbox="443 306 954 338"><b>Figure 6-11 Shim arrangement for gap fill</b></p>  <table border="1" data-bbox="443 940 1471 1344"> <tbody> <tr> <td data-bbox="443 940 678 989">1</td> <td data-bbox="678 940 1471 989">Leveling shims (to make large adjustments to magnet height)</td> </tr> <tr> <td data-bbox="443 989 678 1037">2</td> <td data-bbox="678 989 1471 1037">Duct tape covering shim edges</td> </tr> <tr> <td data-bbox="443 1037 678 1108">3</td> <td data-bbox="678 1037 1471 1108">Contact shims (to make small adjustments in magnet height and to compensate for small localized variations in floor levelness)</td> </tr> <tr> <td data-bbox="443 1108 678 1157">4</td> <td data-bbox="678 1108 1471 1157">Outline of magnet foot</td> </tr> <tr> <td data-bbox="443 1157 678 1205">5</td> <td data-bbox="678 1157 1471 1205">Foot contact with floor</td> </tr> <tr> <td data-bbox="443 1205 678 1253">6</td> <td data-bbox="678 1205 1471 1253">"High" spot</td> </tr> <tr> <td data-bbox="443 1253 678 1302">7</td> <td data-bbox="678 1253 1471 1302">Uneven floor surface</td> </tr> <tr> <td data-bbox="443 1302 678 1344">8</td> <td data-bbox="678 1302 1471 1344">Magnet foot</td> </tr> </tbody> </table>	1	Leveling shims (to make large adjustments to magnet height)	2	Duct tape covering shim edges	3	Contact shims (to make small adjustments in magnet height and to compensate for small localized variations in floor levelness)	4	Outline of magnet foot	5	Foot contact with floor	6	"High" spot	7	Uneven floor surface	8	Magnet foot
1	Leveling shims (to make large adjustments to magnet height)																
2	Duct tape covering shim edges																
3	Contact shims (to make small adjustments in magnet height and to compensate for small localized variations in floor levelness)																
4	Outline of magnet foot																
5	Foot contact with floor																
6	"High" spot																
7	Uneven floor surface																
8	Magnet foot																

## 6.8 Leveling a magnet

1. Complete the following substeps to check front-to-back (superior to inferior) levelness:
  - a. Position a 1000 mm (3 ft) bubble level at the top of the RF coil. Make sure that the entire length of the level is on the RF coil.
  - b. Add leveling shims under each magnet foot, per the [6.7 Adding leveling shims on page 71](#) procedure, to adjust the magnet until the level's bubble fits centrally within the level lines.

**Figure 6-12 Magnet leveling, front-to-back**

2. Complete the following substeps to check left-to-right levelness:
  - a. The magnet level measurement must be taken from the bridge.
  - b. Hold a longer than 305 mm (1 ft) bubble level across the flats of the patient bridge.
  - c. Add leveling shims under each magnet foot, per the [6.7 Adding leveling shims on page 71](#) procedure, to adjust the magnet until the level's bubble fits centrally within the level lines.

**Figure 6-13 Magnet leveling, left-to-right**

3. Complete the following substeps to check magnet height:
  - a. The magnet height measurement must be taken from the magnet endbell (not the bridge) to the finished floor.
  - b. Place a spacer of the same size between the level and magnet endbell from left to right. The illustration below shows two wood blocks as spacers that are both 33 mm (1.25 inches) high.

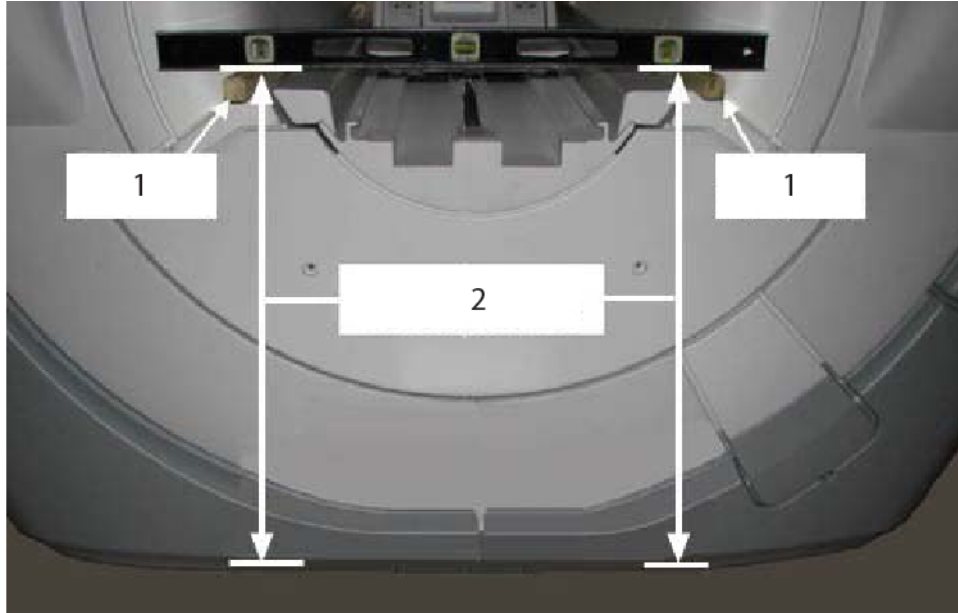
**Figure 6-14 Placement of spacers for supporting the level**

1	Spacer (on endbell)
2	Bottom of level to finished floor

- c. Measure the vertical distance from the bottom of the bubble level to the finished floor.
- d. Add leveling shims under each magnet foot, per the [6.7 Adding leveling shims on page 71](#) procedure, to adjust the magnet to the correct installation height of 956 mm  $\pm$  6 mm (37.625 inches  $\pm$  0.25 inches), which includes the height of the spacer.

**NOTE**

If the magnet exceeds the installation height specification, let the magnet settle on the vibroacoustic damping mat for 24 hours to let the magnet settle on the foam, and then remeasure the magnet height.

**Figure 6-15 Leveling magnet height, left side view (left) and front view (right)**

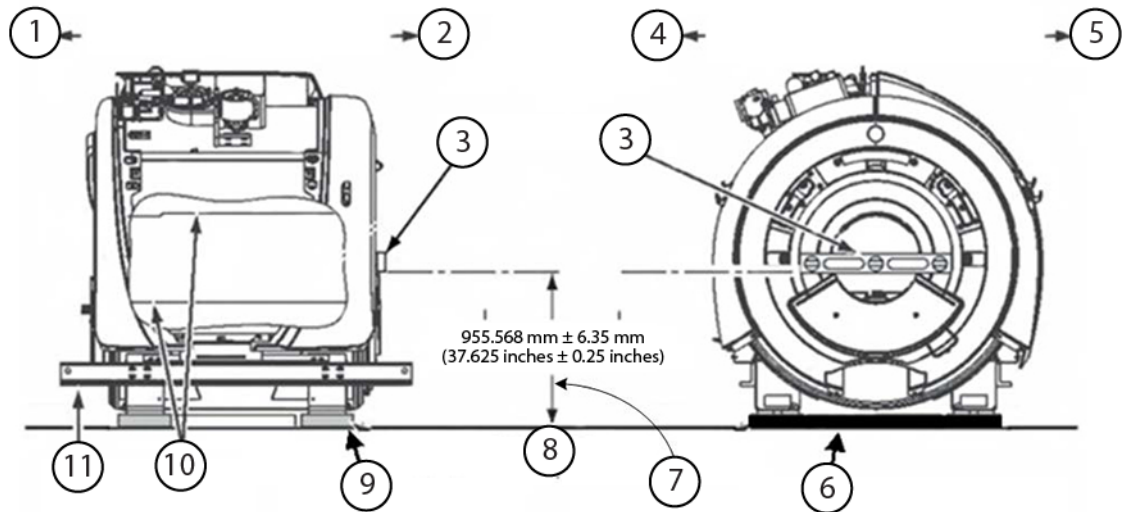

1	Rear
2	Front
3	Carpenter's level(s)
4	Left side
5	Right side
6	Vibroacoustic damping mats
7	Height measurement (to the bottom of the level, and including the 1.25-inch spacer)
8	Finished floor
9	Spacer block
10	Inner bore surface (body coil)
11	Lifting rail

- Repeat this procedure until the front of the magnet is level (left-to-right and front-to-back) and within the correct height specification.

## 6.9 Anchoring the magnet and securing the shim material

Safety	
	<p><b>CAUTION</b></p> <p>POTENTIAL PERSONAL INJURY</p> <p>Contact shims have sharp edges that can cause personal injury.</p> <p>Always tape shim edges to the closest applicable surface (either the floor surface or the vibroacoustic mat).</p>

Safety
<p><b>NOTICE</b></p> <p>EQUIPMENT DAMAGE RISK</p> <p>Improper magnet setup can result in damage to the magnet.</p> <p>Immediately continue with <i>Converting a magnet shipment to operating configuration</i> and <i>Connecting the exhaust gas vent</i> procedures in the appropriate manual:</p> <ul style="list-style-type: none"> <li>• <i>Magnet and Cryogen Manual for 1.5T R Series Magnets</i> (5928384-8EN)</li> <li>• <i>MR Service Safety Manual</i> (5452735)</li> </ul> <p>These documents are available through the support documentation library at <a href="http://gehealthcare.com">gehealthcare.com</a> or your local GE Healthcare Service Representative.</p>
<p><b>NOTICE</b></p> <p>POTENTIAL IMAGE INTERFERENCE</p> <p>Improper magnet setup can result in image problems.</p> <p>The magnet must be connected to the helium exhaust gas vent as soon as possible but within 24 hours.</p> <p>Complete contact between the bottom of the magnet feet and the floor or vibroacoustic mat is important to minimize magnet motion/vibration.</p>

Tools and test equipment*			
Item	Quantity	Part number	Manufacturer
0.75-10 x 4 inch Stainless Steel Studs	-	5477278	-
Washer, Plain, 0.75 x 0.100 THK, Stainless Steel Flat Washers	-	46-252635P14	-
76.8 x 76.8 mm (3 x 3 inch) Aluminum Washers	-	5476688	-
0.75-10 Stainless Steel Nuts	-	46-260943P6	-

\*This table applies to non-SV products.

1. **(For non-SV product systems)** Using the anchoring hardware, anchor the magnet to the vibroacoustic mat. Make sure all fasteners are properly tightened (finger-tight plus ½ turn).

**(For SV product systems)** No anchoring is needed in this configuration.

**NOTE**

If necessary, refer to the appropriate *Preinstallation Manual* (see [Appendix B Preinstallation Manual reference on page 107](#)) for the magnet style being installed.

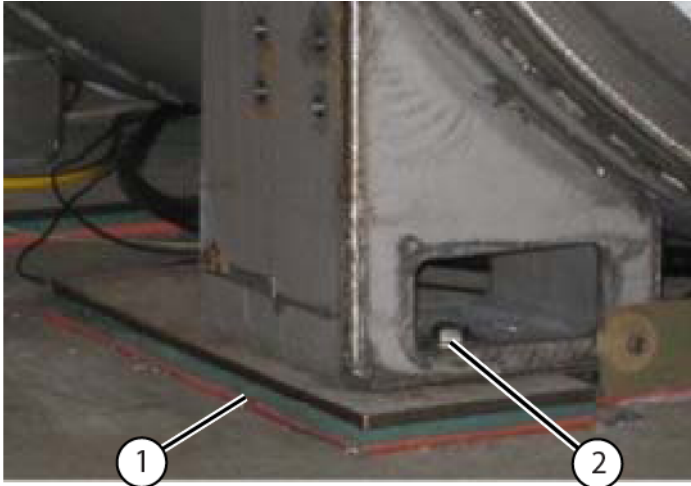
**Figure 6-16 Magnet anchoring, shown with aluminum spacer removed\***

1	Vibroacoustic mat
2	Anchoring hardware

\*This image is a representation to show anchoring; your actual magnet and vibroacoustic mat may differ from those in this image.

2. Trim off excess shim material.

3. Tape shim edges to the closest applicable surface (either the floor surface or the vibroacoustic mat), and based on the type of vibroacoustic mat:

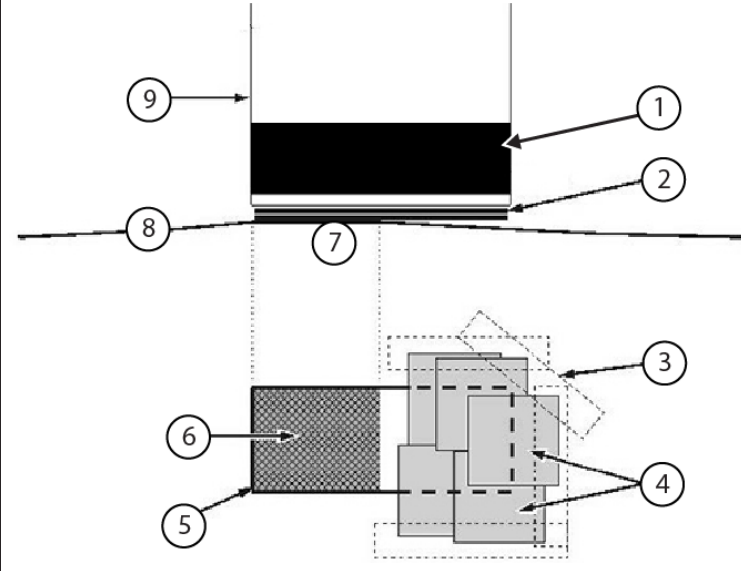
Vibroacoustic mat type	Procedure																		
SV	<p>Put the shims on the floor, under the vibroacoustic mat's aluminum plate.</p> <p><b>Figure 6-17 Shim arrangement for gap fill</b></p>  <table border="1" data-bbox="440 1029 1481 1499"> <tr> <td>1</td> <td>Vibroacoustic mat</td> </tr> <tr> <td>2</td> <td>Leveling shims (to make large adjustments to magnet height)</td> </tr> <tr> <td>3</td> <td>Duct tape covering shim edges</td> </tr> <tr> <td>4</td> <td>Contact shims (to make small adjustments in magnet height and to compensate for small localized variations in floor levelness)</td> </tr> <tr> <td>5</td> <td>Outline of magnet foot</td> </tr> <tr> <td>6</td> <td>Foot contact with floor</td> </tr> <tr> <td>7</td> <td>"High" spot</td> </tr> <tr> <td>8</td> <td>Uneven floor surface</td> </tr> <tr> <td>9</td> <td>Magnet foot</td> </tr> </table>	1	Vibroacoustic mat	2	Leveling shims (to make large adjustments to magnet height)	3	Duct tape covering shim edges	4	Contact shims (to make small adjustments in magnet height and to compensate for small localized variations in floor levelness)	5	Outline of magnet foot	6	Foot contact with floor	7	"High" spot	8	Uneven floor surface	9	Magnet foot
1	Vibroacoustic mat																		
2	Leveling shims (to make large adjustments to magnet height)																		
3	Duct tape covering shim edges																		
4	Contact shims (to make small adjustments in magnet height and to compensate for small localized variations in floor levelness)																		
5	Outline of magnet foot																		
6	Foot contact with floor																		
7	"High" spot																		
8	Uneven floor surface																		
9	Magnet foot																		

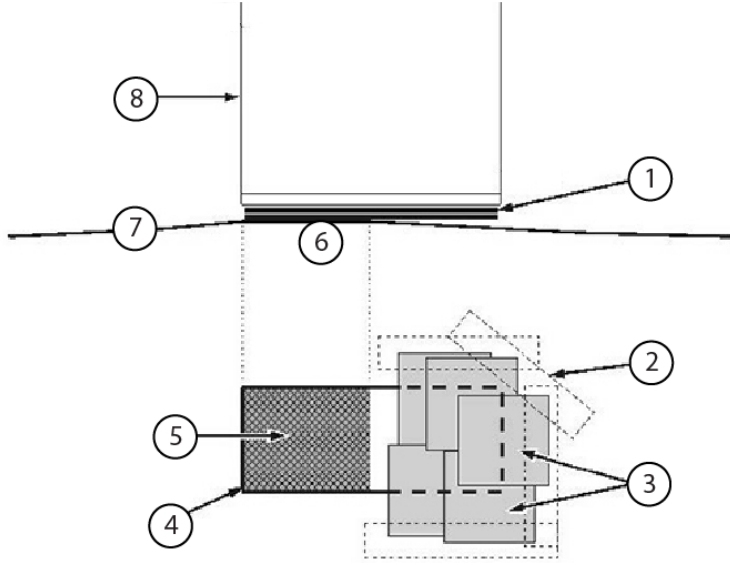
Vibro-acoustic mat type	Procedure																
Non-SV	<p data-bbox="443 258 1442 289">Put the shims between the magnet foot and the stainless steel surface of the vibroacoustic mat.</p> <p data-bbox="443 306 956 338"><b>Figure 6-18 Shim arrangement for gap fill</b></p>  <table border="1" data-bbox="443 940 1469 1344"> <tbody> <tr> <td data-bbox="446 945 678 982">1</td> <td data-bbox="678 945 1466 982">Leveling shims (to make large adjustments to magnet height)</td> </tr> <tr> <td data-bbox="446 982 678 1020">2</td> <td data-bbox="678 982 1466 1020">Duct tape covering shim edges</td> </tr> <tr> <td data-bbox="446 1020 678 1108">3</td> <td data-bbox="678 1020 1466 1108">Contact shims (to make small adjustments in magnet height and to compensate for small localized variations in floor levelness)</td> </tr> <tr> <td data-bbox="446 1108 678 1146">4</td> <td data-bbox="678 1108 1466 1146">Outline of magnet foot</td> </tr> <tr> <td data-bbox="446 1146 678 1184">5</td> <td data-bbox="678 1146 1466 1184">Foot contact with floor</td> </tr> <tr> <td data-bbox="446 1184 678 1222">6</td> <td data-bbox="678 1184 1466 1222">"High" spot</td> </tr> <tr> <td data-bbox="446 1222 678 1260">7</td> <td data-bbox="678 1222 1466 1260">Uneven floor surface</td> </tr> <tr> <td data-bbox="446 1260 678 1297">8</td> <td data-bbox="678 1260 1466 1297">Magnet foot</td> </tr> </tbody> </table>	1	Leveling shims (to make large adjustments to magnet height)	2	Duct tape covering shim edges	3	Contact shims (to make small adjustments in magnet height and to compensate for small localized variations in floor levelness)	4	Outline of magnet foot	5	Foot contact with floor	6	"High" spot	7	Uneven floor surface	8	Magnet foot
1	Leveling shims (to make large adjustments to magnet height)																
2	Duct tape covering shim edges																
3	Contact shims (to make small adjustments in magnet height and to compensate for small localized variations in floor levelness)																
4	Outline of magnet foot																
5	Foot contact with floor																
6	"High" spot																
7	Uneven floor surface																
8	Magnet foot																

## Chapter 7 Installing a seismic vibroacoustic damping mat and leveling the magnet

Safety	
	<p><b>CAUTION</b></p> <p><b>HEAVY OBJECT</b></p> <p>Improper lifting of non-SV damping mats can result in personal injury.</p> <p>Each surface mounted non-SV vibroacoustic damping mat weighs ~105 kg (250 lbs). Do not lift or move mats alone without mechanical assistance.</p>
	<p><b>NOTICE</b></p> <p><b>EQUIPMENT DAMAGE RISK</b></p> <p>Improper damping mat installation can result in damage to the magnet.</p> <p>Tasks in this section must be done by riggers, not GE Service Personnel. The surface mounted vibroacoustic damping mats must be installed on the floor before moving the magnet into the magnet room.</p>

### 7.1 Equipment overview

Tools and test equipment			
Item	Quantity	Part number	Manufacturer
305 mm (1 foot) Bubble Level in good condition; no sharp edges, corners, dents, bumps, cracks or loose bubble vials.	1	-	-
1000 mm (3 foot) Bubble Level in good condition; no sharp edges, corners, dents, bumps, cracks or loose bubble vials.	1	-	-
Tape Measure	1	-	-
Magnet Leveling Kit (contents detailed in table below)	1	46-260888G4	-
SV Vibroacoustic Damping Kit	1 of these kits	M50002LP	-
Vibroacoustic Damping Option A		M1060MA	-

<b>Magnet Leveling Kit (46-260888G4)</b>			
<b>Item</b>	<b>Quantity</b>	<b>Part number</b>	<b>Manufacturer</b>
Leveling Shim, 1.57 mm (0.062 inches) thick	12	2213945	-
Leveling Shim, 0.51 mm (0.020 inches) thick	8	2213945-2	-
Contact Shim, 152 x 152 x 0.51 mm (6.00 x 6.00 x 0.20 inches thick)	24	2180016	-
Contact Shim, 152 x 152 x 0.81 mm (6.00 x 6.00 x 0.32 inches thick)	16	2180016-2	-
Contact Shim, 152 x 152 x 1.0 mm (6.00 x 6.00 x 0.40 inches thick)	8	2180016-3	-
Contact Shim, 152 x 152 x 1.6 mm (6.00 x 6.00 x 0.63 inches thick)	4	2180016-4	-

<b>Required conditions</b>
Magnet and dock installation and placement are critical to image quality and hardware reliability.
The magnet must be installed level with the isocenter to the specifications of the magnet height listed in the <a href="#">7.9 Leveling a magnet on page 97</a> procedure.

## 7.2 Positioning a non-SV seismic mounted vibroacoustic damping mat

1. Make sure that the vibroacoustic kit contains the parts listed in the following table.

**Table 7-1 Vibroacoustic damping mat kit (M1060MA)**

<b>Quantity</b>	<b>Part number</b>	<b>Description</b>
1 pair	5122574	Vibroacoustic Damping Mat, one Labeled FRONT and one Labeled REAR
4	5476688	76.8 x 76.8 mm (3 x 3 inch) Aluminum Washers*
4	5477278	0.75-10 x 4 inch Stainless Steel Studs*
4	46-260943P6	0.75-10 Stainless Steel Nuts*
4	46-252635P14	Washer, Plain, 0.75 x 0.100 THK, Stainless Steel Flat Washers*
4	5394873	Sleeve, for M20 Seismic Anchor

\*For anchoring the magnet to surface-mounted vibroacoustic damping mats.

2. Make sure the M1060MA vibroacoustic damping mats consist of two identical plates.

**Figure 7-1 Surface mounted non-SV vibroacoustic damping mats**



**NOTE**

The 3 x 3 washer, SS stud, SS nut, and flat washer pointed out above is shown on the mat for illustration purposes only. It needs to be positioned inside the magnet foot to secure the magnet foot to the mat.

- Put the vibroacoustic damping mats on the floor, according to the prescribed markings.

**Figure 7-2 Vibroacoustic mat placement for seismic applications**

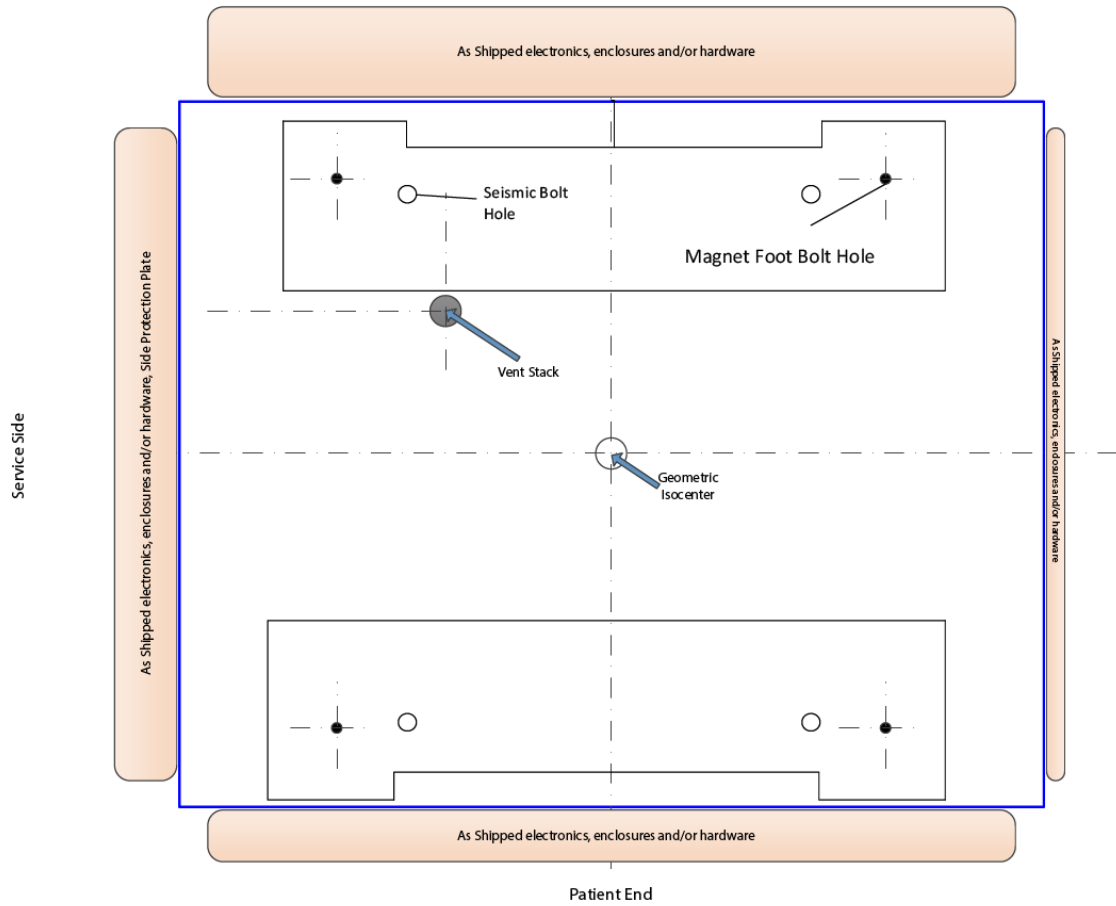

- Center the vibroacoustic mats based on the magnet geometric isocenter or the 8-inch quench vent location.

## 7.3 Positioning a seismic mounted SV vibroacoustic damping mat

- Make sure that the SV vibroacoustic kit contains the parts listed in the following table.

**Table 7-2 SV vibroacoustic damping mat kit (M50002LP)**

Quantity	Part number	Description
2	5420414	Vibro pad
2	5420414-2	Vibro pad

**NOTE**

The kit consists of two sets of two identical plates.

- Identify the magnet geometric isocenter based on the vent stack location as shown in the magnet footprint below.

**Figure 7-3 SV vibroacoustic mat placement (M50002LP)**

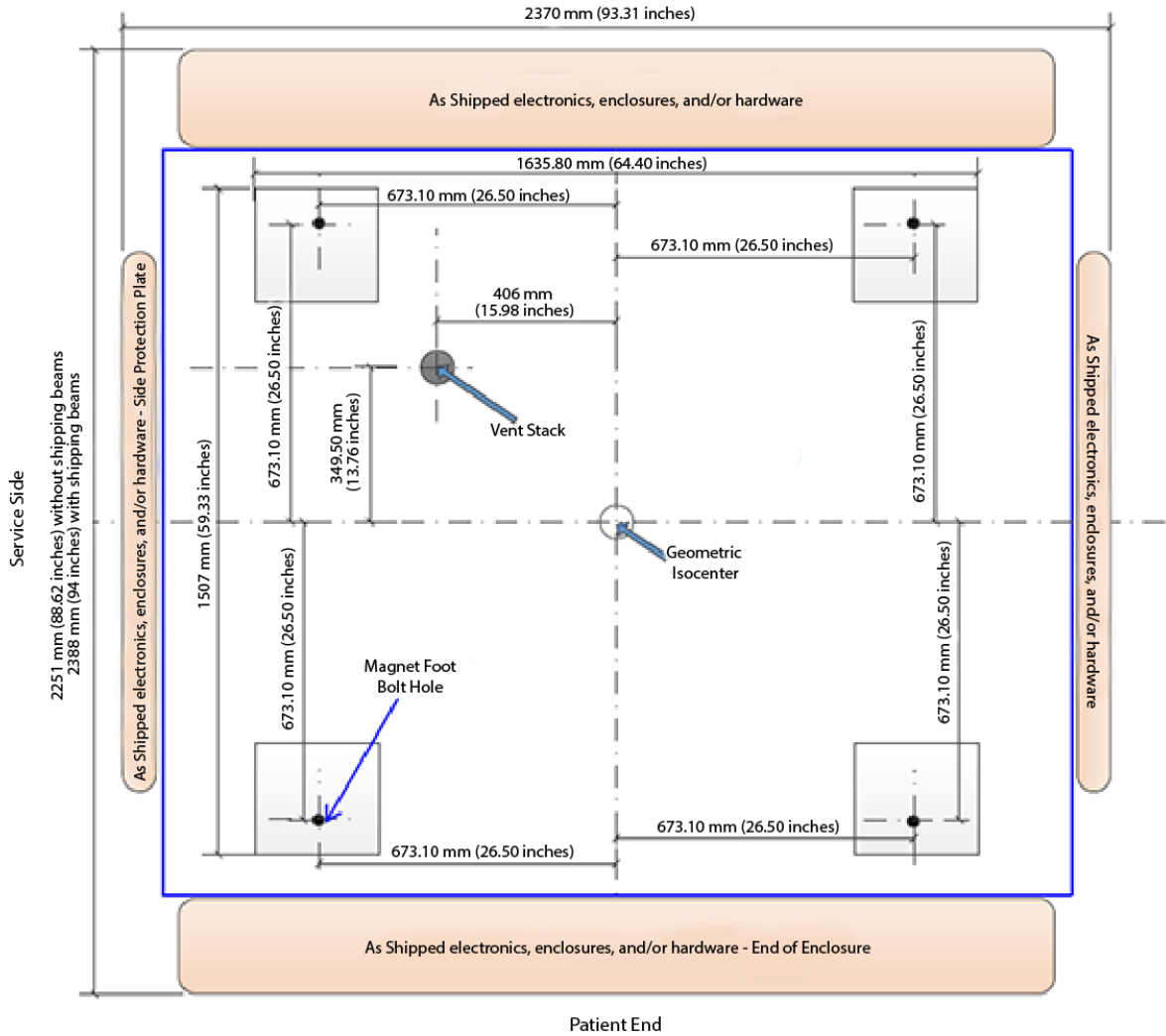

- Put the SV vibroacoustic mats where magnet feet will be located, spaced as shown in the previous and next illustrations.

**Figure 7-4 SV vibroacoustic mats, magnet rear/service (top) and magnet front/patient (bottom)**

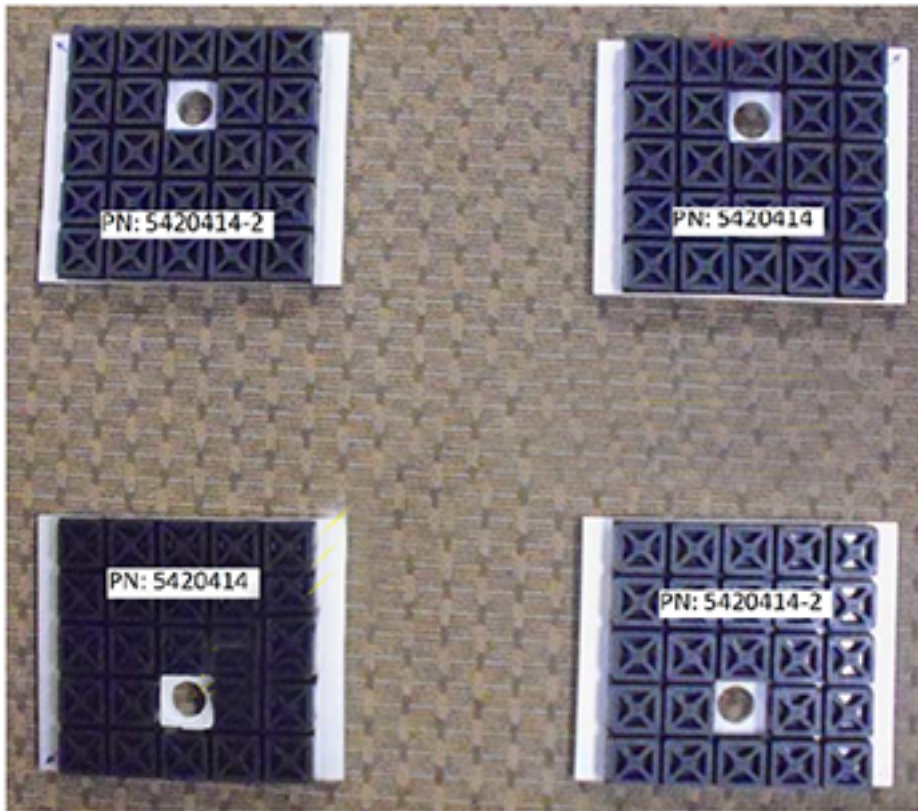

- Position the mats so that the rubber dampener will face up against the magnet foot and the aluminum plate faces down against the floor.

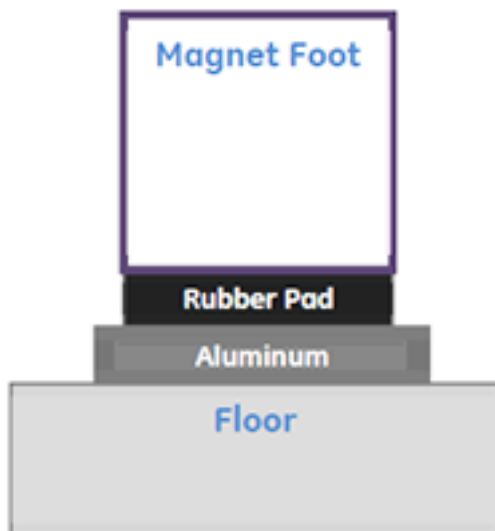

## 7.4 Seismic mounting of a vibroacoustic damping mat to the floor

**(For SV vibroacoustic damping mat)** If a magnet with SV vibroacoustic damping mat M50002LP is being seismically mounted, the customer is responsible for the seismic mounting.

The following mounting depiction is one of many ways to install magnets seismically and by no means is the mandatory method.

**Figure 7-5 Recommended SV seismic installation layout**

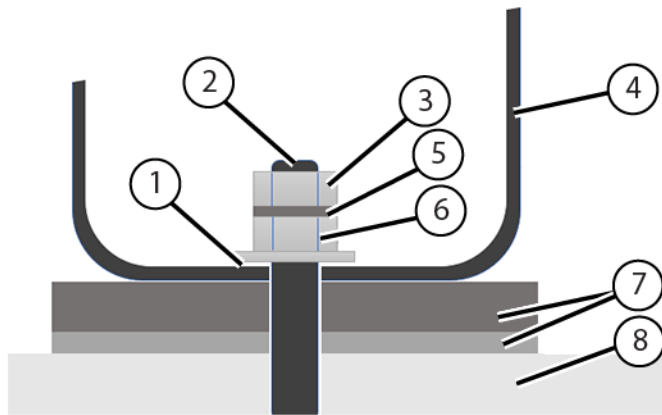

1	1/16 inch air gap
2	Seismic rod
3	Jam nut
4	Magnet foot
5	Lock washer
6	Flange nut
7	SV vibroacoustic damping mat
8	Concrete floor



The customer is also responsible for making sure that the seismic rod diameter and all hardware meets seismic requirements. The jam nut, flange nut, and lock washer must meet the diameter of the rod the customer selects.

Make sure that there is an approximately 1/16 inch gap between the flange nut and the magnet foot. If there is not a gap, vibrations will bypass the vibroacoustic damping mat and cause imaging issues.

**(For non-SV vibroacoustic damping mat)** If a magnet with a non-SV vibroacoustic damping mat is being seismically mounted, the customer is responsible for the seismic mounting. The seismic mounting method is up to the client.

The customer is also responsible for making sure that the seismic rod diameter and all hardware meets seismic requirements. The customer chooses which seismic rods to use. These anchor rods go into seismic holes that are built into the vibromats.

## 7.5 Preparing to move the magnet

Safety	
	<p><b>DANGER</b></p> <p>POTENTIAL ASPHYXIATION HAZARD</p> <p>Loss of magnet vacuum will result in the rapid expulsion of helium gas, which can cause asphyxiation in enclosed areas.</p> <p>Make sure that hospital personnel are aware of this situation prior to the magnet being moved within the enclosed areas. Use extreme caution and do not contact or damage the vacuum vessel during magnet transit or siting.</p>
	<p><b>WARNING</b></p> <p>POTENTIAL INJURY HAZARD</p> <p>Moving the magnet improperly will cause personal injury or magnet damage.</p> <p>See <a href="#">Chapter 2 Unloading and moving the magnet on page 13</a> before moving the magnet using a forklift or crane.</p>
	<p><b>NOTICE</b></p> <p>EQUIPMENT DAMAGE RISK</p> <p>Improper transportation can result in damage to the magnet.</p> <p>Tasks in this section are to be done by riggers, not by GE HealthCare Personnel.</p> <p>Do not apply any force to the magnet's enclosures.</p> <p>Any floor anchors that are used to move the magnet must not penetrate the RF shield.</p> <p>Magnet and dock installation and placement are critical to image quality and hardware reliability. The magnet must be installed level with the isocenter to the specifications listed in this chapter.</p>
	<p><b>NOTICE</b></p> <p>EQUIPMENT DAMAGE RISK</p> <p>Improper magnet height can result in damage to the magnet if you try to move the magnet to a low ceiling area.</p> <p>The 1-inch aluminum spacer plate can be removed from each magnet foot. Refer to the steps in this procedure to remove the aluminum spacers.</p> <p>Do not remove the 1-inch spacers until you are ready to put the magnet on the vibroacoustic pads. Contact the Install Base Leader at GEHC Florence for further instruction.</p>

After the magnet is moved to the building using a crane or forklift (see [Chapter 2 Unloading and moving the magnet on page 13](#)), it needs to be moved to the magnet room. There are many methods to help move the magnet, including the use of a motorized tow vehicle, a come-along, or a chain jack. When you are moving the magnet, make sure that you are moving it in a smooth, controlled manner.

**NOTE**

Remove the lifting rails and bubble wrap at any point forward when the process allows, and you are done using the rails. When removing the bubble wrap, do not nick or cut any electrical cables.

1. Optionally, roller dollies are recommended for moving the magnet inside a building. If you use roller dollies, put steel floor plates along the magnet delivery route.

**Figure 7-6 Magnet on roller dollies**

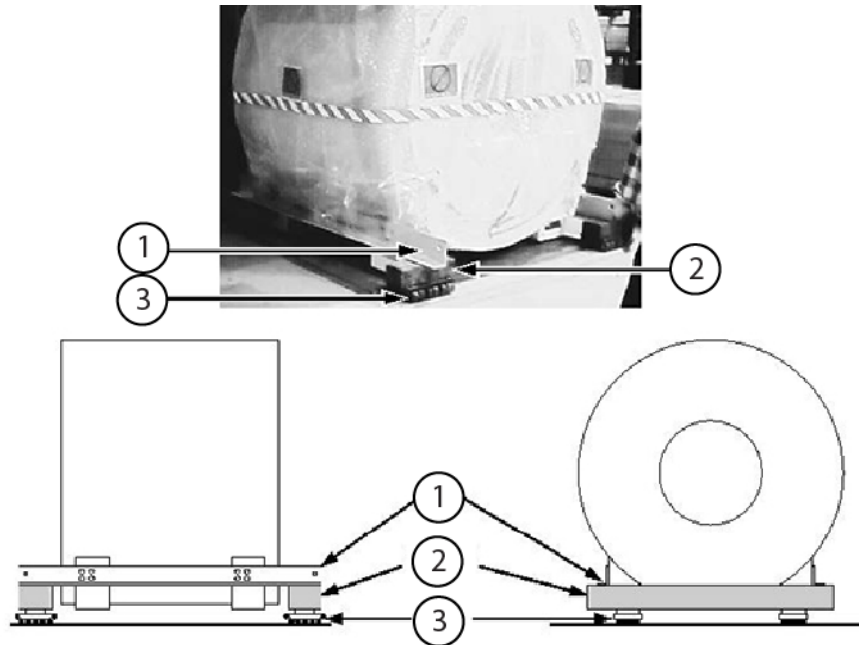

1	Lifting rails
2	100 mm x 150 mm (4 inch x 6 inch) wood beams
3	Roller dollies

2. Have the rigger make sure that walls, floors, and so on along the transportation route are protected from potential damage.
3. Attach any cables, chains, or straps used for moving the magnet to the orange lifting rails.
4. Make sure that the magnet front-rear orientation is relative to the magnet room's front and rear.
5. Do a check of all clearances along the route that the magnet will move to get to the magnet room. Compare those clearances with the appropriate illustration below.

**NOTE**

Magnet image is shown for reference and may differ from the configuration shipped. The dimensions indicated are for the condition as shipped.

**NOTE**

Dimensions referenced are worst-case scenarios.

**Figure 7-7 Clearance dimensions, magnet patient end as-shipped condition**

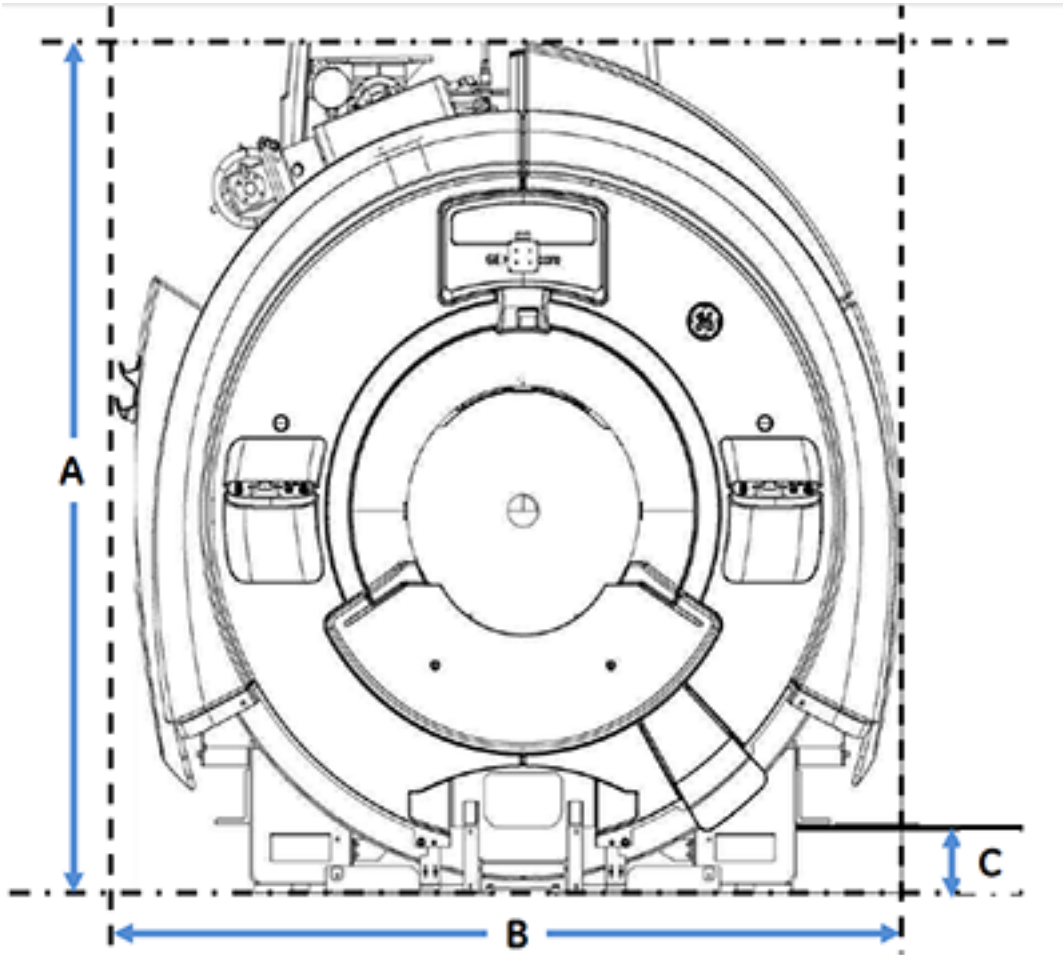

A	2383 mm (93.83 inches)
B	2370 mm (93.31 inches)
C	193 mm (7.60 inches)

**Figure 7-8 Clearance dimensions, magnet service side as-shipped condition**

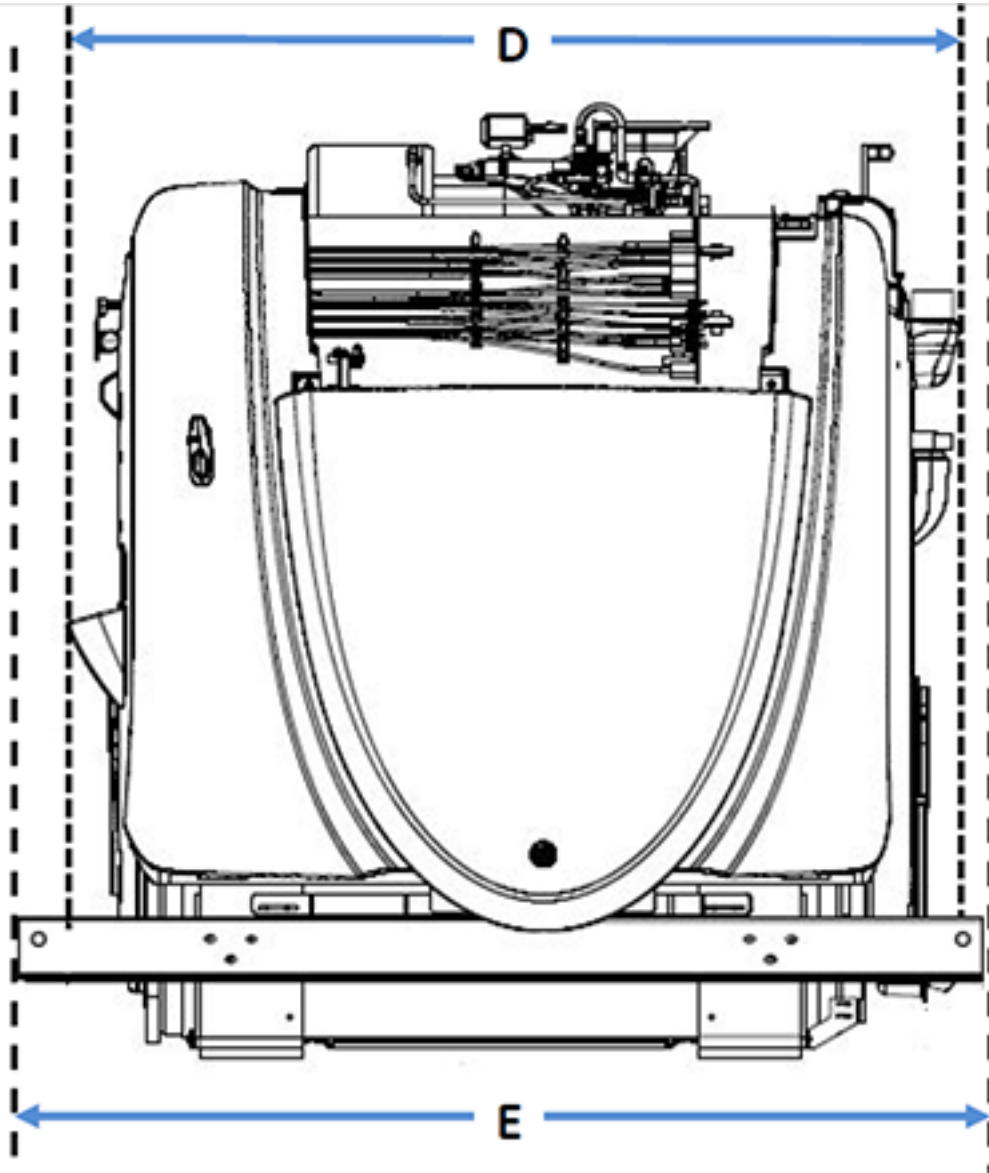

D	2251 mm (88.62 inches)
E	2388 mm (94.00 inches)

6. Compare the dimensions of the magnet on the moving fixtures being used with the clearances measured along the magnet delivery route. The height can be reduced by putting the moving fixtures directly under the lifting rails.

## 7.6 Moving the magnet into the MR suite

Safety	
	<p><b>CAUTION</b></p> <p>POTENTIAL PERSONAL INJURY</p> <p>Uneven jacking of the magnet's corners could result in the magnet shifting on the jacks, which may lead to personal injury or magnet damage.</p> <p>Keep the magnet level at all times during any jacking operation.</p>
	<p><b>NOTICE</b></p> <p>EQUIPMENT DAMAGE RISK</p> <p>Improper loads on enclosure cover parts can result in damage to the enclosure.</p> <p>Do not apply any loads to enclosure cover parts.</p> <p>Do not allow straps, cables, or chains to scrape enclosure cover parts.</p>

1. If raising the magnet is required, the lifting portion of the jack must be fully below the lifting rails.
2. Avoid tilting or rotating the magnet while moving it into the MR suite.
3. From the magnet room entrance to the magnet's final position, put steel floor plates as needed to protect the magnet room floor. The rigger must take actions necessary to make sure that walls, floors, and so on along the transportation route/path are protected from potential damage.
4. Move the magnet to the magnet room. (If using a motorized tow vehicle, attach cables, chains, or straps to the magnet's lifting rails with shackles.)

## 7.7 Lowering the magnet into position

1. Cut open and remove enough of the bubble wrap to allow access to the feet and for leveling operations.

### NOTE

When cutting off the bubble wrap, do not nick or cut any electrical cables.

2. Move the magnet to align the holes in the magnet feet, based on the type of vibroacoustic mat:

Vibroacoustic mat type	Procedure
<b>SV</b>	<ol style="list-style-type: none"> <li>1. Align the holes in the magnet feet to the magnet feet bolt holes in the vibroacoustic damping mats or the magnet anchors or the seismic anchor holes in the SV vibroacoustic mats.</li> <li>2. Make sure that the four holes, one per each magnet foot, align centered <math>\pm 3</math> mm (<math>\pm 0.125</math> inches) over the anchor stud holes in the vibroacoustic damping mats or the magnet anchors or over the seismic anchor holes in the SV vibroacoustic mats.</li> </ol>
<b>Non-SV</b>	<ol style="list-style-type: none"> <li>1. Align the holes in the magnet feet to the magnet feet bolt holes in the vibroacoustic damping mats.</li> <li>2. Make sure that the four holes, one per each magnet foot, align centered <math>\pm 3</math> mm (<math>\pm 0.125</math> inches) over the magnet feet bolt holes in the vibroacoustic damping mats.</li> </ol>

3. Jack the magnet up sufficiently at the two lifting rails (four corners), and remove the moving fixtures.
4. To remove the 1-inch aluminum spacer from each magnet foot, complete the following substeps:
  - a. Find a  $\frac{3}{4}$  inch (19 mm) wrench.
  - b. Remove the two  $\frac{3}{8}$  inch hex-head bolts that secure the 25 mm (1 inch) aluminum spacer to each foot.
  - c. Remove and store the aluminum spacers on-site.

**Figure 7-9 Bolts securing aluminum spacer**

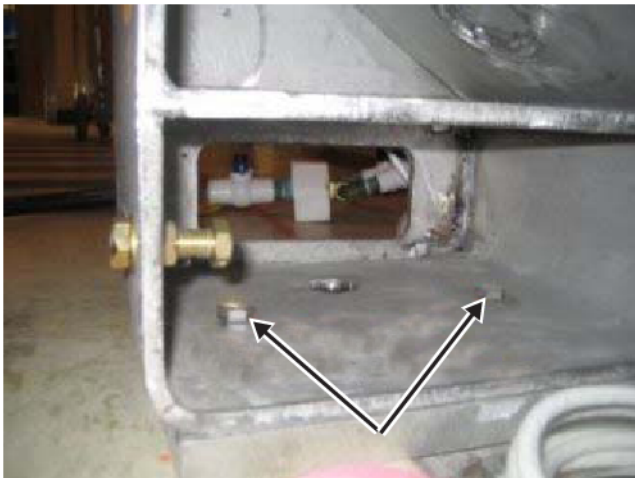

- Slowly lower the magnet onto the vibroacoustic mats.

**Figure 7-10 Moving the magnet onto surface mounted non-SV vibroacoustic damping mats**



1	Floor protection
2	Vibroacoustic damping mat
3	Magnet anchor holes
4	Magnet front

- Release pressure simultaneously in both jacks on one end of the magnet until that end is 25 to 50 mm (1 to 2 inches) lower than the opposite end.
- Simultaneously lower both jacks on the other end 25 to 50 mm (1 to 2 inches).
- Repeat lowering the magnet end to end until all feet are on the vibroacoustic mats, correctly located on the magnet feet bolt holes.

**Figure 7-11 Magnet installed on surface mounted non-SV vibroacoustic damping mats**



## 7.8 Adding leveling shims

Review this section before you begin to level the magnet. If, while leveling the magnet, you need to insert shims under a magnet foot to achieve correct leveling, this section provides instructions for raising any one of the four magnet feet and properly placing shims with respect to the specific vibroacoustic mat.

1. Use a jack to raise the lowest magnet foot.
2. Insert the appropriate thickness of aluminum shim plates under the low magnet foot.

**Table 7-3 Leveling shim placement**

	<b>SV</b>	<b>Non-SV</b>
<b>Vibroacoustic mat (VM)</b>	M50002LP	M1060MA
<b>Leveling shim placement</b>	On the floor, beneath the VM aluminum plate	Between the magnet foot and the stainless steel surface of the VM
<b>Remove 1-inch Al spacer from each foot?</b>	Yes, before final positioning in MR suite	
<b>Floor anchoring</b>	Refer to the appropriate <i>Preinstallation Manual</i> (see <a href="#">Appendix B Preinstallation Manual reference on page 107</a> ).	

3. Put the shims in position, based on the type of vibroacoustic mat:

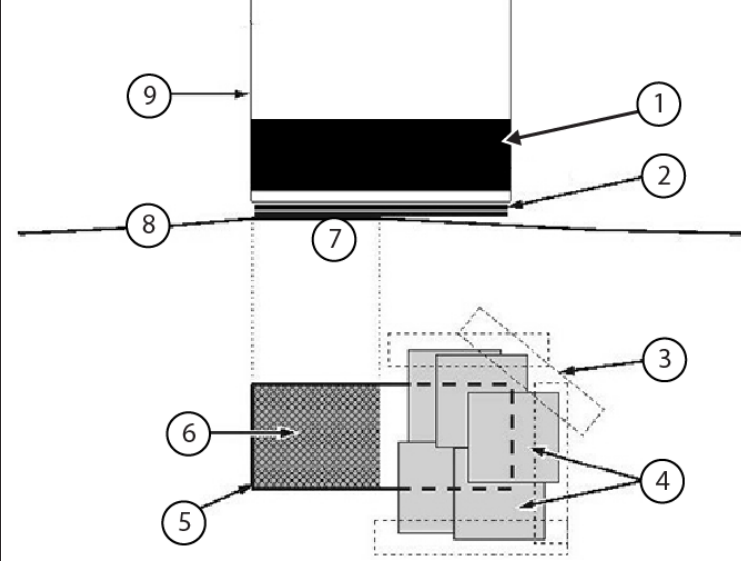
Vibroacoustic mat type	Procedure																		
SV	<p>Put the shims on the floor, under the vibroacoustic mat's aluminum plate.</p> <p><b>Figure 7-12 Shim arrangement for gap fill</b></p>  <table border="1" data-bbox="440 997 1481 1463"> <tbody> <tr> <td>1</td> <td>Vibroacoustic mat</td> </tr> <tr> <td>2</td> <td>Leveling shims (to make large adjustments to magnet height)</td> </tr> <tr> <td>3</td> <td>Duct tape covering shim edges</td> </tr> <tr> <td>4</td> <td>Contact shims (to make small adjustments in magnet height and to compensate for small localized variations in floor levelness)</td> </tr> <tr> <td>5</td> <td>Outline of magnet foot</td> </tr> <tr> <td>6</td> <td>Foot contact with floor</td> </tr> <tr> <td>7</td> <td>"High" spot</td> </tr> <tr> <td>8</td> <td>Uneven floor surface</td> </tr> <tr> <td>9</td> <td>Magnet foot</td> </tr> </tbody> </table>	1	Vibroacoustic mat	2	Leveling shims (to make large adjustments to magnet height)	3	Duct tape covering shim edges	4	Contact shims (to make small adjustments in magnet height and to compensate for small localized variations in floor levelness)	5	Outline of magnet foot	6	Foot contact with floor	7	"High" spot	8	Uneven floor surface	9	Magnet foot
1	Vibroacoustic mat																		
2	Leveling shims (to make large adjustments to magnet height)																		
3	Duct tape covering shim edges																		
4	Contact shims (to make small adjustments in magnet height and to compensate for small localized variations in floor levelness)																		
5	Outline of magnet foot																		
6	Foot contact with floor																		
7	"High" spot																		
8	Uneven floor surface																		
9	Magnet foot																		

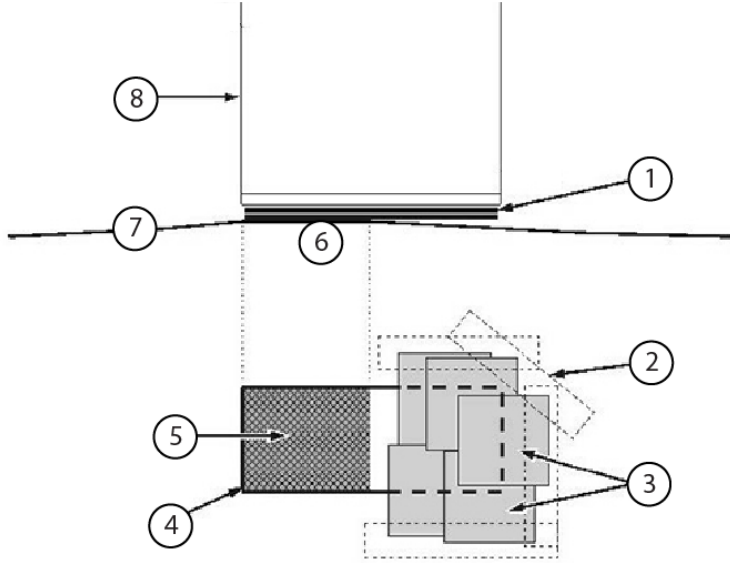
Vibro-acoustic mat type	Procedure																
Non-SV	<p>Put the shims between the magnet foot and the stainless steel surface of the vibroacoustic mat.</p> <p><b>Figure 7-13 Shim arrangement for gap fill</b></p>  <table border="1" data-bbox="451 940 1468 1344"> <tbody> <tr> <td>1</td> <td>Leveling shims (to make large adjustments to magnet height)</td> </tr> <tr> <td>2</td> <td>Duct tape covering shim edges</td> </tr> <tr> <td>3</td> <td>Contact shims (to make small adjustments in magnet height and to compensate for small localized variations in floor levelness)</td> </tr> <tr> <td>4</td> <td>Outline of magnet foot</td> </tr> <tr> <td>5</td> <td>Foot contact with floor</td> </tr> <tr> <td>6</td> <td>"High" spot</td> </tr> <tr> <td>7</td> <td>Uneven floor surface</td> </tr> <tr> <td>8</td> <td>Magnet foot</td> </tr> </tbody> </table>	1	Leveling shims (to make large adjustments to magnet height)	2	Duct tape covering shim edges	3	Contact shims (to make small adjustments in magnet height and to compensate for small localized variations in floor levelness)	4	Outline of magnet foot	5	Foot contact with floor	6	"High" spot	7	Uneven floor surface	8	Magnet foot
1	Leveling shims (to make large adjustments to magnet height)																
2	Duct tape covering shim edges																
3	Contact shims (to make small adjustments in magnet height and to compensate for small localized variations in floor levelness)																
4	Outline of magnet foot																
5	Foot contact with floor																
6	"High" spot																
7	Uneven floor surface																
8	Magnet foot																

## 7.9 Leveling a magnet

1. Complete the following substeps to check front-to-back (superior to inferior) levelness:
  - a. Position a 1000 mm (3 ft) bubble level at the top of the RF coil. Make sure that the entire length of the level is on the RF coil.
  - b. Add leveling shims under each magnet foot, per the [7.8 Adding leveling shims on page 95](#) procedure, to adjust the magnet until the level's bubble fits centrally within the level lines.

**Figure 7-14 Magnet leveling, front-to-back**

2. Complete the following substeps to check left-to-right levelness:
  - a. The magnet level measurement must be taken from the bridge.
  - b. Hold a longer than 305 mm (1 ft) bubble level across the flats of the patient bridge.
  - c. Add leveling shims under each magnet foot, per the [7.8 Adding leveling shims on page 95](#) procedure, to adjust the magnet until the level's bubble fits centrally within the level lines.

**Figure 7-15 Magnet leveling, left-to-right**

3. Complete the following substeps to check magnet height:
  - a. The magnet height measurement must be taken from the magnet endbell (not the bridge) to the finished floor.
  - b. Place a spacer of the same size between the level and magnet endbell from left to right. The illustration below shows two wood blocks as spacers that are both 33 mm (1.25 inches) high.

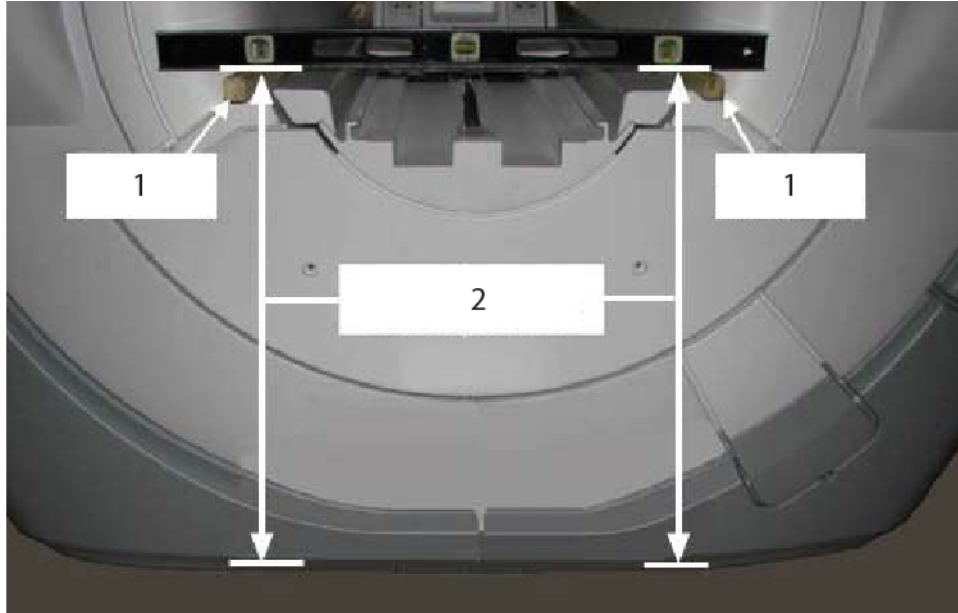
**Figure 7-16 Placement of spacers for supporting the level**

1	Spacer (on endbell)
2	Bottom of level to finished floor

- c. Measure the vertical distance from the bottom of the bubble level to the finished floor.
- d. Add leveling shims under each magnet foot, per the [7.8 Adding leveling shims on page 95](#) procedure, to adjust the magnet to the correct installation height of 956 mm  $\pm$  6 mm (37.625 inches  $\pm$  0.25 inches), which includes the height of the spacer.

**NOTE**

If the magnet exceeds the installation height specification, let the magnet settle on the vibroacoustic damping mat for 24 hours to let the magnet settle on the foam, and then remeasure the magnet height.

**Figure 7-17 Leveling magnet height, left side view (left) and front view (right)**

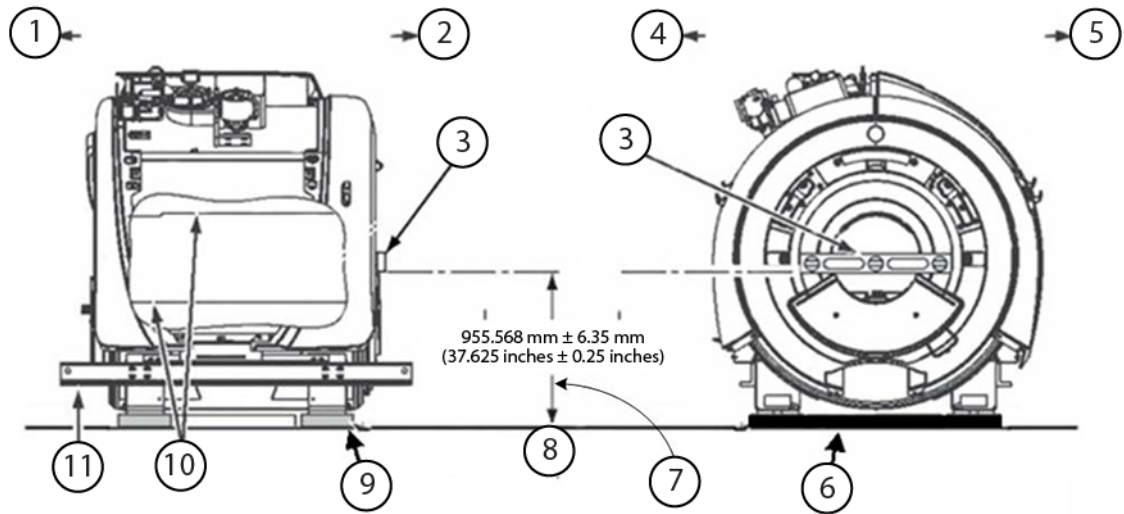

1	Rear
2	Front
3	Carpenter's level(s)
4	Left side
5	Right side
6	Vibroacoustic damping mats
7	Height measurement (to the bottom of the level, and including the 1.25-inch spacer)
8	Finished floor
9	Spacer block
10	Inner bore surface (body coil)
11	Lifting rail

- Repeat this procedure until the front of the magnet is level (left-to-right and front-to-back) and within the correct height specification.

## 7.10 Anchoring the magnet and securing the shim material

Safety	
	<p><b>CAUTION</b></p> <p>POTENTIAL PERSONAL INJURY</p> <p>Contact shims have sharp edges that can cause personal injury.</p> <p>Always tape shim edges to the closest applicable surface (either the floor surface or the vibroacoustic mat).</p>

Safety
<p><b>NOTICE</b></p> <p>EQUIPMENT DAMAGE RISK</p> <p>Improper magnet setup can result in damage to the magnet.</p> <p>Immediately continue with <i>Converting a magnet shipment to operating configuration</i> and <i>Connecting the exhaust gas vent</i> procedures in the appropriate manual:</p> <ul style="list-style-type: none"> <li>• <i>Magnet and Cryogen Manual for 1.5T R Series Magnets</i> (5928384-8EN)</li> <li>• <i>MR Service Safety Manual</i> (5452735)</li> </ul> <p>These documents are available through the support documentation library at <a href="http://gehealthcare.com">gehealthcare.com</a> or your local GE Healthcare Service Representative.</p>
<p><b>NOTICE</b></p> <p>POTENTIAL IMAGE INTERFERENCE</p> <p>Improper magnet setup can result in image problems.</p> <p>The magnet must be connected to the helium exhaust gas vent as soon as possible but within 24 hours.</p> <p>Complete contact between the bottom of the magnet feet and the floor or vibroacoustic mat is important to minimize magnet motion/vibration.</p>

Tools and test equipment*			
Item	Quantity	Part number	Manufacturer
0.75-10 x 4 inch Stainless Steel Studs	-	5477278	-
Washer, Plain, 0.75 x 0.100 THK, Stainless Steel Flat Washers	-	46-252635P14	-
76.8 x 76.8 mm (3 x 3 inch) Aluminum Washers	-	5476688	-
0.75-10 Stainless Steel Nuts	-	46-260943P6	-

\*This table applies to non-SV products.

1. **(For non-SV product systems)** Using the anchoring hardware, anchor the magnet to the vibroacoustic mat. Make sure all fasteners are properly tightened (finger-tight plus ½ turn).

**NOTE**

If necessary, refer to the appropriate *Preinstallation Manual* (see [Appendix B Preinstallation Manual reference on page 107](#)) for the magnet style being installed.

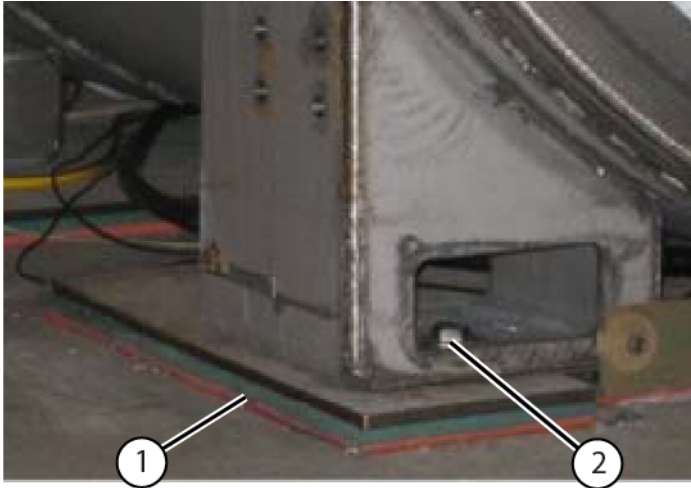
**Figure 7-18 Magnet anchoring, shown with aluminum spacer removed\***

1	Vibroacoustic mat
2	Anchoring hardware

\*This image is a representation to show anchoring; your actual magnet and vibroacoustic mat may differ from those in this image.

2. Trim off excess shim material.

3. Tape shim edges to the closest applicable surface (either the floor surface or the vibroacoustic mat), and based on the type of vibroacoustic mat:

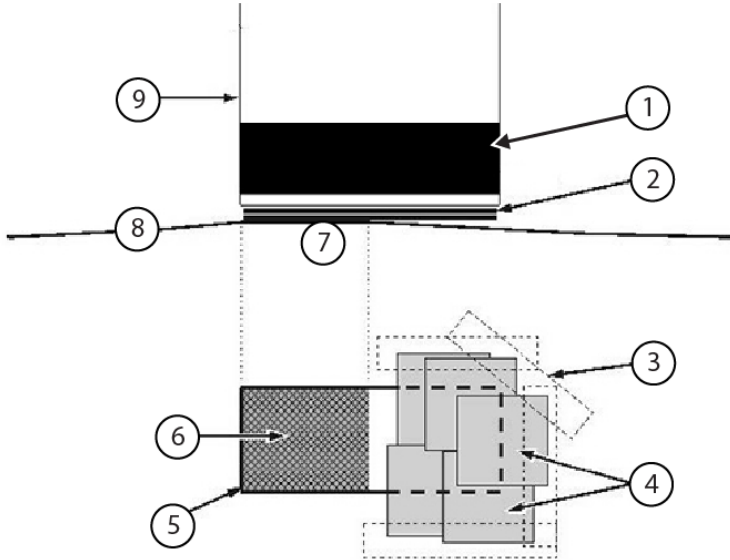
Vibroacoustic mat type	Procedure																		
SV	<p>Put the shims on the floor, under the vibroacoustic mat's aluminum plate.</p> <p><b>Figure 7-19 Shim arrangement for gap fill</b></p>  <table border="1" data-bbox="446 1029 1469 1480"> <tbody> <tr> <td>1</td> <td>Vibroacoustic mat</td> </tr> <tr> <td>2</td> <td>Leveling shims (to make large adjustments to magnet height)</td> </tr> <tr> <td>3</td> <td>Duct tape covering shim edges</td> </tr> <tr> <td>4</td> <td>Contact shims (to make small adjustments in magnet height and to compensate for small localized variations in floor levelness)</td> </tr> <tr> <td>5</td> <td>Outline of magnet foot</td> </tr> <tr> <td>6</td> <td>Foot contact with floor</td> </tr> <tr> <td>7</td> <td>"High" spot</td> </tr> <tr> <td>8</td> <td>Uneven floor surface</td> </tr> <tr> <td>9</td> <td>Magnet foot</td> </tr> </tbody> </table>	1	Vibroacoustic mat	2	Leveling shims (to make large adjustments to magnet height)	3	Duct tape covering shim edges	4	Contact shims (to make small adjustments in magnet height and to compensate for small localized variations in floor levelness)	5	Outline of magnet foot	6	Foot contact with floor	7	"High" spot	8	Uneven floor surface	9	Magnet foot
1	Vibroacoustic mat																		
2	Leveling shims (to make large adjustments to magnet height)																		
3	Duct tape covering shim edges																		
4	Contact shims (to make small adjustments in magnet height and to compensate for small localized variations in floor levelness)																		
5	Outline of magnet foot																		
6	Foot contact with floor																		
7	"High" spot																		
8	Uneven floor surface																		
9	Magnet foot																		

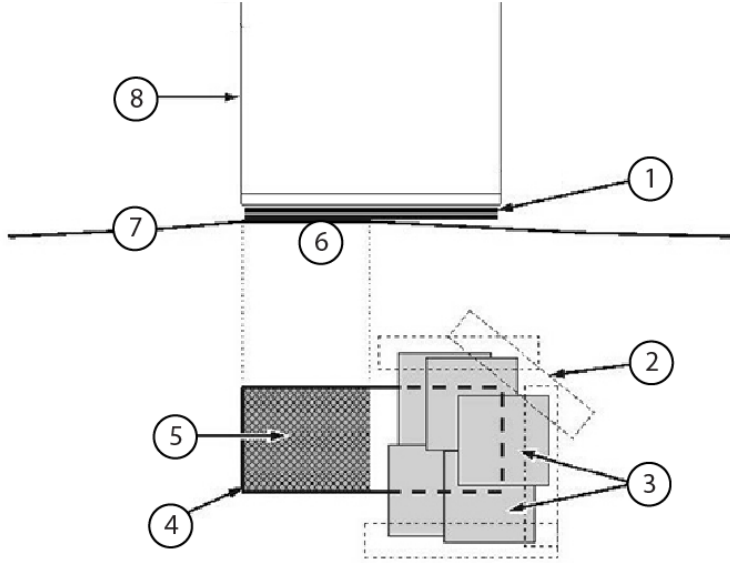
Vibro-acoustic mat type	Procedure																
Non-SV	<p data-bbox="443 258 1442 289">Put the shims between the magnet foot and the stainless steel surface of the vibroacoustic mat.</p> <p data-bbox="443 306 956 338"><b>Figure 7-20 Shim arrangement for gap fill</b></p>  <table border="1" data-bbox="443 940 1469 1346"> <tbody> <tr> <td data-bbox="443 940 678 989">1</td> <td data-bbox="678 940 1469 989">Leveling shims (to make large adjustments to magnet height)</td> </tr> <tr> <td data-bbox="443 989 678 1037">2</td> <td data-bbox="678 989 1469 1037">Duct tape covering shim edges</td> </tr> <tr> <td data-bbox="443 1037 678 1108">3</td> <td data-bbox="678 1037 1469 1108">Contact shims (to make small adjustments in magnet height and to compensate for small localized variations in floor levelness)</td> </tr> <tr> <td data-bbox="443 1108 678 1157">4</td> <td data-bbox="678 1108 1469 1157">Outline of magnet foot</td> </tr> <tr> <td data-bbox="443 1157 678 1205">5</td> <td data-bbox="678 1157 1469 1205">Foot contact with floor</td> </tr> <tr> <td data-bbox="443 1205 678 1253">6</td> <td data-bbox="678 1205 1469 1253">"High" spot</td> </tr> <tr> <td data-bbox="443 1253 678 1302">7</td> <td data-bbox="678 1253 1469 1302">Uneven floor surface</td> </tr> <tr> <td data-bbox="443 1302 678 1346">8</td> <td data-bbox="678 1302 1469 1346">Magnet foot</td> </tr> </tbody> </table>	1	Leveling shims (to make large adjustments to magnet height)	2	Duct tape covering shim edges	3	Contact shims (to make small adjustments in magnet height and to compensate for small localized variations in floor levelness)	4	Outline of magnet foot	5	Foot contact with floor	6	"High" spot	7	Uneven floor surface	8	Magnet foot
1	Leveling shims (to make large adjustments to magnet height)																
2	Duct tape covering shim edges																
3	Contact shims (to make small adjustments in magnet height and to compensate for small localized variations in floor levelness)																
4	Outline of magnet foot																
5	Foot contact with floor																
6	"High" spot																
7	Uneven floor surface																
8	Magnet foot																

# Appendix A Magnet footprint

Figure A-1 Magnet footprint

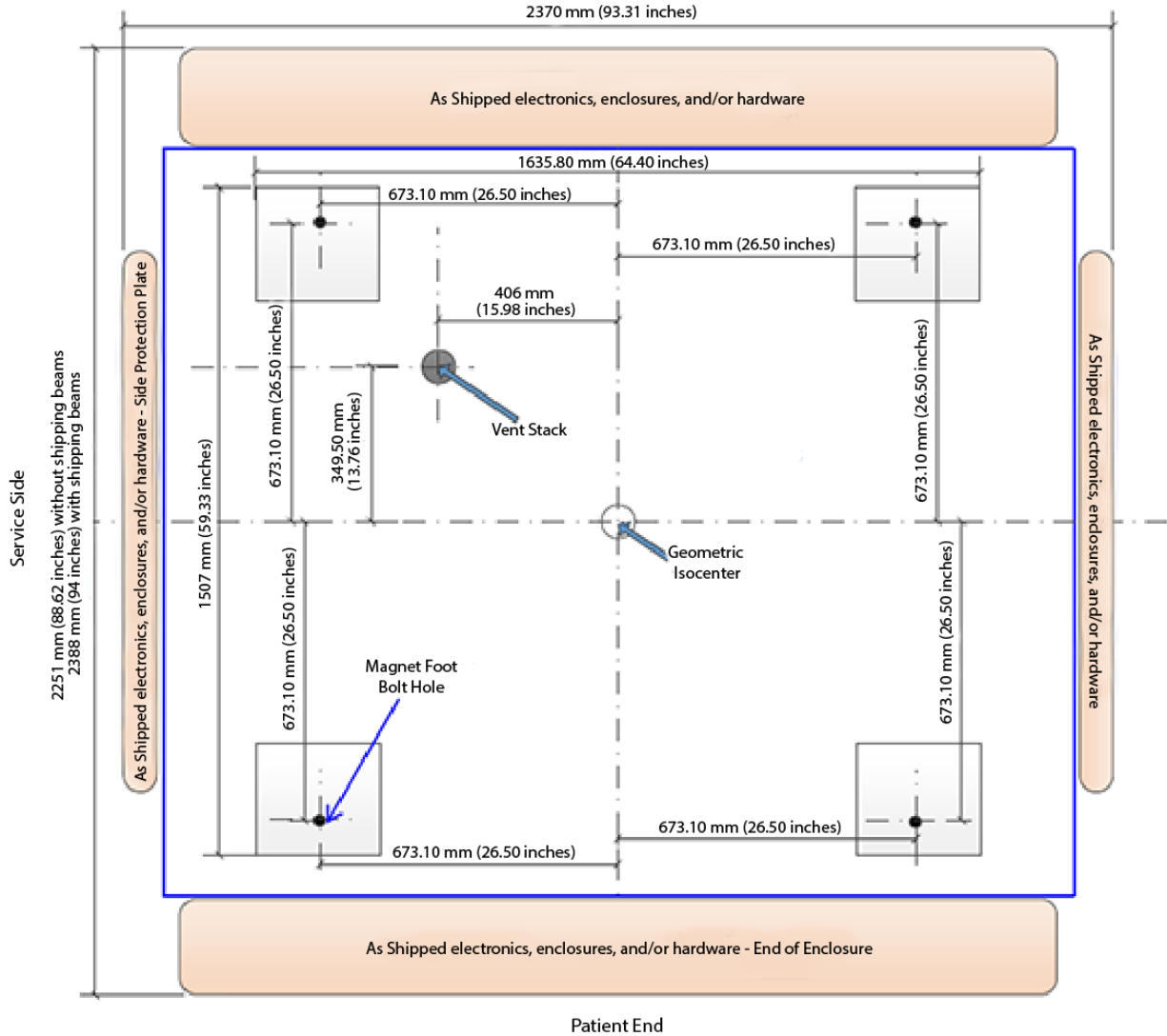

Page intentionally left blank

## Appendix B *Preinstallation Manual* reference

### NOTE

The table below contains a selection of manuals for product systems with an R series magnet. It is not an exhaustive list.

Description	Direction or part number
Signa Excite 1.5T Pre-Installation Manual	2223170
Signa Excite HD 1.5T Pre-Installation	5133301
Signa HDxt 1.5T Pre-Installation	5159901
Optima MR360 / Brivo MR355 Preinstallation Manual	5433834-1EN
Discovery MR450 Pre-Installation	5500109
SIGNA™ Creator/SIGNA™ Explorer Preinstallation Manual	5538857-1EN

Page intentionally left blank

## Revision History

Revision	Date	Description
Controlled document for English is posted as DOC2344965.		

Revision	Date	Description
2	February 2023	<ul style="list-style-type: none"> <li>• The Revision History was moved to the end of the manual.</li> <li>• Updated all dimensions to show metric first.</li> <li>• Modified some word choices and number formats to match style.</li> <li>• Changed references to Magnet and Cryogen Manual for Actively Shimmed Magnets (5495019) to Magnet and Cryogen Manual for 1.5T R Series Magnets (5928384-8EN).</li> <li>• In section 1.1 Overview, Table 1-1 Magnet handling functions and responsibilities: <ul style="list-style-type: none"> <li>◦ In row 7, updated the Responsibility from "Rigger" to "Rigger and GE Field Engineer".</li> <li>◦ Consolidated rows 9, 10, and 11 into a single row 9.</li> </ul> </li> <li>• In section 1.3, Truck loading specifications: <ul style="list-style-type: none"> <li>◦ The required condition about the maximum of two magnets per trailer was updated to include AR configurations.</li> <li>◦ Table 1-2 Magnet loading specifications, changed the maximum shock load label from "Gs" to "g".</li> </ul> </li> <li>• The following changes were made to Chapter 2, Unloading and moving the magnet, to reflect CAPA-00013781: <ul style="list-style-type: none"> <li>◦ In section 2.1, Shipping and crate configurations, the Safety table now includes a caution requiring two people to lift the magnet lifting rails and a warning against using damaged mounting hardware.</li> <li>◦ In section 2.7, Removing the shipping crate, added step 15, a procedure about examining witness marks before lifting with the orange rails. A note referring to this new step was added in the following locations: <ul style="list-style-type: none"> <li>• Section 2.8, Unloading and moving the uncrated magnet with a forklift, before step 1.</li> <li>• Section 2.9, Unloading the uncrated magnet with a crane to ground, before step 3.</li> <li>• Section 2.10, Lifting the magnet with a crane through the opening in the exterior wall, before step 4.</li> </ul> </li> </ul> </li> <li>• In section 2.1, Shipping and crate configurations: <ul style="list-style-type: none"> <li>◦ In the Safety table, "(if used)" was added after two "spreader beam" references.</li> <li>◦ For the Domestic Shipping Crate (5151624), changed "Not approved for flight usage." to "Not approved for flight or ocean usage." For the 106-inch Shipping Crate (5140792) and 96-inch Shipping Crate (5334870), changed "Approved for use on truck or air transportation." to "Approved for use on truck, ocean, or air transportation."</li> </ul> </li> <li>• In section 2.2, Equipment requirements, in Table 2-2 Crane requirements, "(if used)" was added after "Spreader beam quantity".</li> <li>• In section 2.4, Handling the crated magnet in transit with a crane: <ul style="list-style-type: none"> <li>◦ Added "crated" to the title for clarification and to parallel the title in section 2.5.</li> <li>◦ Updated step 1 from "If you are using a crane, you need" to "Using a crane requires" so the sentence more clearly aligns with the previous statement that a crane is not being used.</li> <li>◦ Removed step 2 (avoid tilting the magnet), since the magnet is not moved in this section.</li> </ul> </li> </ul>

Revision	Date	Description
		<ul style="list-style-type: none"> <li>• In section 2.5, Handling the crated magnet in transit with a forklift, the note in step 3 was updated to state "Magnet lift must be perpendicular to magnet bore." Previously it said "parallel."</li> <li>• The notice in section 2.6, Removing the shipping cage, about improper removal of the shipping cage had incorrect language referencing the crate. To fix this, the following changes were made: <ul style="list-style-type: none"> <li>◦ The notice, as is, was added to section 2.7, Removing the shipping crate, and the first and only instance of "cage" was changed to "crate".</li> <li>◦ In section 2.6, the last two points were removed, as they only apply to the crate, and the remaining instances of "crate" were changed to "cage".</li> </ul> </li> <li>• In section 2.6, Removing the shipping cage: <ul style="list-style-type: none"> <li>◦ Updated callout 3 in the second notice from "Crate" to "Cage".</li> <li>◦ Added steps 1 and 2 about removing the tarp, unstrapping the cage, and unchaining the magnet.</li> </ul> </li> <li>• In section 2.7, Removing the shipping crate, added a note to step 7 to clarify that the use of the spreader beam shown in the figure is optional.</li> <li>• In the following sections, added a note about rigger responsibilities after the Safety table. <ul style="list-style-type: none"> <li>◦ 2.8, Unloading and moving the uncrated magnet with a forklift</li> <li>◦ 2.9, Unloading the uncrated magnet with a crane to ground</li> <li>◦ 2.10, Lifting the magnet with a crane through the opening in the exterior wall</li> </ul> </li> <li>• The hazard statements in section 2.9, Unloading the uncrated magnet with a crane to ground, and section 2.10, Lifting the magnet with a crane through the opening in the exterior wall, were consolidated. Both sections now include the same two warnings and two notices.</li> <li>• In sections 2.9, Unloading the uncrated magnet with a crane to ground, and 2.10, Lifting the magnet with a crane through the opening in the exterior wall, updated step 2. Changed "spreader beam" to "spreader beam (if used)," and added a sentence about what to do if a spreader beam is not used.</li> <li>• In section 3.1, Connecting the magnet to the compressor, the following changes were made: <ul style="list-style-type: none"> <li>◦ Added an electric shock warning that includes LOTO to the Safety table.</li> <li>◦ Replaced the class M Sumitomo vendor manuals in the equipment damage notice (CD32ZZ-056, CD32ZZ-060, CD32ZZ-271, CD32ZZ-272, CD32ZZ-273, CD32ZZ-420, CD32ZZ-501, CD32ZZ-530, CD32ZZ-543) with class A Sumitomo vendor manuals (CD32ZZ-226, CD32ZZ-227, CD32ZZ-067, CD32ZZ-073, CD32ZZ-080).</li> <li>◦ Added step 3, "Connect the cooling water for the compressor (or do a check of the connection, if already connected)."</li> <li>◦ Added step 4, "Make sure that the default running mode is internal. FE or warehouse staff must not change this."</li> <li>◦ In step 5, updated the figure <i>Coldhead compressor connections</i>.</li> </ul> </li> </ul>

Revision	Date	Description
		<ul style="list-style-type: none"> <li>◦ In step 6, for the F-50 compressor "turning on" instructions, added substep 1 about input power voltage connections for new compressor installations.</li> <li>◦ In step 6, for the F-50 compressor "turning off" instructions, added substeps 2 and 3 for LOTO and gas line disconnection.</li> <li>◦ In step 6, for the F50SH compressor "turning on" instructions, added substep 4, "Do a check for warnings or alarms."</li> <li>• In section 3.2, Connecting the magnet monitoring connections, added step 2, "Connect Cable, Run 850 MON J-2 to Compressor RS232 (5807125) from the Magnet Monitor to the compressor." This step applies to F50SH compressors.</li> <li>• In section 3.2, Connecting the magnet monitoring connections, and section 3.3, Connecting the warehouse magnet monitoring connections, an additional step was added to "Close the V3 valve during storage to prevent helium loss from the 15.7 psia valve."</li> <li>• In section 3.5, Monitoring the magnet at the warehouse: <ul style="list-style-type: none"> <li>◦ Changed the arrival pressure in step 1 from "between 5 psig and 7 psig" to "greater than 1.3 psi, depending on the site elevation".</li> <li>◦ Updated step 2 for consistency.</li> <li>◦ Changed step 3 from "Make sure that the pressure is not &lt; 0.9 psig." to "Make sure the pressure stabilizes at approximately 0.8 psi."</li> </ul> </li> <li>• In section 4.1, Preparing to do an in-transit helium refill: <ul style="list-style-type: none"> <li>◦ Removed the text "In-transit helium refill is done based upon the magnet shipping date per the documents stated in the notice above. Access the plumbing through the access panels identified in the illustration below." and the <i>Crate access panels</i> figure. This information is not necessary to handle the magnet in transit.</li> <li>◦ The following changes were made to reflect DOC2486031: <ul style="list-style-type: none"> <li>• The figure <i>Hardware/plug in bag secured to plumbing on plumbing assembly</i> and the table <i>Small items attached to magnet plumbing</i> were removed.</li> <li>• The figure <i>In-transit plumbing configuration</i> was updated.</li> <li>• The figure <i>Configuration of a magnet shipped by air or ocean</i> was updated.</li> <li>• The figure <i>Domestic storage configuration, including shipping hose and placard</i> was renamed to <i>Configuration of a domestically shipped magnet</i> and its corresponding callout table updated. The note (including figure <i>Vent adapter replaced with blanking plate assembly</i>) was removed.</li> <li>• In the paragraph preceding the procedure steps, replaced "...will need to do the following steps to first disconnect the shipping hose from the Nupro valve so that you can attach a pressure gauge to this port." with "...can connect a device to the Nupro valve output on the shim lead."</li> <li>• In the paragraph preceding the procedure steps, replaced "The following steps explain how to disconnect the shipping hose, when to do the liquid helium fill, and how to reconnect the shipping hose to the magnet after the liquid helium fill is complete." with "The following steps explain how to reconnect the 5.25 psi valve, when to do the liquid</li> </ul> </li> </ul> </li> </ul>

Revision	Date	Description
		<p>helium fill, and how to disconnect the 5.25 psi valve again for international shipment after the liquid helium fill is complete."</p> <ul style="list-style-type: none"> <li>• In the note preceding the procedure steps, replaced "...reconnect the shipping hose to the magnet." with "...disconnect the 5.25 psi valve for international shipment. For domestic transportation it can remain connected."</li> <li>• Removed former steps 1, 2, and 3, which related to the Nupro valve and hardware bag with tube cap and restriction cap.</li> <li>• In step 1, updated the image <i>Raising the shim lead</i>.</li> <li>• In steps 2, 3, and 11, changed "NPT/V3 valve" to "V3 valve".</li> <li>• Removed step 8, "While holding the Nupro valve securely in place, loosen the 0.25 inch compression nut and disconnect the shipping hose from the Nupro valve." including the "Loosen the 0.25 inch compression nut" figure.</li> <li>• Changed step 9 (now step 5) from "Disconnect the shipping hose from the NPT/V3 valve." to "Cut the zip tie securing the 5.25 psi valve, and remove the caps from the T-adapter and 5.25 psi valve. Reconnect the 5.25 psi valve to the T-adapter." Updated the corresponding figure from "Disconnecting the shipping hose from the NPT/V3 valve" to "Reconnecting the 5.25 psi valve to the V3 valve."</li> <li>• Removed step 10, "Remove the 0.50 inch tube cap from the hardware bag."</li> <li>• Removed step 11, "Tighten the tube cap to the top of the NPT/V3 female fitting, where the shipping hose was previously attached." including the "Tube cap, attached to the NPT/V3 female fitting" figure.</li> <li>• Added the sentence "Make sure the Nupro valve is open." to step 12 (now step 6).</li> <li>• Added the sentence "Close the Nupro valve." to step 14 (now step 8).</li> <li>• Replaced steps 15 through 22 with the following steps: <ol style="list-style-type: none"> <li>1. Make sure the magnet pressure is below 0.5 psig.</li> <li>2. Disconnect the 5.25 psi valve from the V3 T-adapter. Replace the caps on the 5.25 psi valve and T-adapter (only required for international shipment).</li> </ol> </li> <li>• Removed step 24, "Make sure that the restriction cap and tube cap are in the plastic hardware bag, and secure the bag to the plumbing assembly with a zip tie."</li> <li>• In the note in step 25 (now step 12), replaced "0.5 psig" with "15.7 psia".</li> <li>• In Chapter 5, Preparing the scan room, the "equipment damage risk" notice was removed. A statement that "Handling of vibroacoustic damping mats must be done by riggers, not GE service personnel" was added to the existing "heavy object" caution.</li> <li>• Added a "heavy object" caution to the beginning of Chapters 6 and 7.</li> <li>• In sections 6.1 and 7.1, Equipment overview, the hammer and wood driving block were removed from the tools table.</li> </ul>

Revision	Date	Description
		<ul style="list-style-type: none"> <li>• In sections 6.4 and 7.5, Preparing to move the magnet, the significant digits in the clearance dimensions were updated for consistency to two decimal places for inches and whole numbers for millimeters.</li> <li>• In section 6.5, Moving the magnet into the MR suite, changed step 7 from "Make sure that all points on the service side of the magnet are equidistant from the wall." to "Make sure there is clearance for the service ladder."</li> <li>• In section 6.6, Lowering the magnet into position, in step 8 changed "...until all feet are on the floor." to "until all feet are on the vibroacoustic mats."</li> <li>• In step 4.a in sections 6.6 and 7.7, Lowering the magnet into position, M19 was changed to 19 mm.</li> <li>• In section 6.7, Adding leveling shims, floor anchoring references were removed from the <i>Leveling shim placement</i> table in step 2.</li> <li>• In step 3.d of sections 6.8 and 7.9, Leveling a magnet, the metric value of the magnet installation height was updated from 955.675 mm ± 6.35 mm to 956 mm ± 6 mm.</li> <li>• In section 6.9, Anchoring the magnet and securing the shim material, step 1 was updated to include an SV statement for clarification: "No anchoring is needed in this configuration."</li> <li>• In section 7.8, Adding leveling shims, redundant seismic references and the "Magnet to vibroacoustic mat anchor" row were removed from the <i>Leveling shim placement</i> table in step 2.</li> <li>• Appendix B, Vibroacoustic damping mat wall chart, was removed.</li> <li>• Appendix C (now Appendix B), Preinstallation Manual reference, was updated to only list manuals for systems with R series magnets, and with a note to clarify that the table does not contain an exhaustive list of all product systems.</li> </ul>

Revision	Date	Description
1	18 February 2020	<p>Initial release of content specific to magnet series, routed in MyWorkshop as DOC2344965, Revision 2; previously magnet handling information was released as a single document, 5475706, Revision 6.</p> <ul style="list-style-type: none"> <li>• Document format updated to reflect SIMS standards.</li> <li>• Content specific to a magnet series other than R is no longer included in this magnet-specific document.</li> <li>• Cross-references replaced any textual references to chapters or sections.</li> <li>• All references to VibroAcoustic were updated to vibroacoustic; all references to vibromat were updated to vibroacoustic damping mat.</li> <li>• The Language Policy was removed.</li> <li>• Chapter 1, Damage in Transportation, was renamed to section 1.2, Examining packages for damage in transportation; the text was updated for format, and reflects the same language now used in all installation and upgrade manuals moving forward.</li> <li>• Chapter 2, Safety Alert Usage, was replaced with the updated Safety table in section 1.1, Overview.</li> <li>• Chapter 3, Overview, was renamed to Chapter 1, Getting started. <ul style="list-style-type: none"> <li>◦ In paragraph one, the definition of the magnet serial number was updated to be specific to the series.</li> <li>◦ Paragraphs two and three were moved after Table 1 for better flow.</li> <li>◦ Paragraph three was updated to reflect the replacement of the support documentation library with SIMS Content Viewer.</li> <li>◦ Cross-references to appropriate chapters and sections were added to Table 1, where applicable.</li> </ul> </li> <li>• Chapter 4, Truck Loading Specs, was renamed to section 1.3, Truck loading specifications. <ul style="list-style-type: none"> <li>◦ The Caution and Notice were formatted correctly into a single Notice.</li> <li>◦ The Shipping Capability in Table 2, Magnet loading specifications, was replaced with Shipping temperature.</li> <li>◦ The content in Note 1 was moved to the Allowable shipping modes column in Table 2, Magnet loading specifications.</li> <li>◦ Notes 2, 3, and 4 were moved to the Required Conditions table; the content of Note 3 was paired with Figure 1 and 2, and updated to include PM series configurations.</li> </ul> </li> <li>• Chapter 5, Pre-Delivery Instructions, was renamed to section 1.4, Predelivery instructions. <ul style="list-style-type: none"> <li>◦ The Notice was formatted correctly and split into two Notices.</li> <li>◦ Mention of the mats in step 5.2.3 (now 2.c) was intentionally removed and reliance on the <i>Preinstallation Manual</i> emphasized.</li> <li>◦ Cross-references to the new Preinstallation Manual (PIM) appendix were added to steps that referenced the PIM.</li> </ul> </li> <li>• Chapter 6, Magnet Unloading and Movement, was renamed to Chapter 2, Unloading and moving the magnet, and the first Warning was changed to a Danger.</li> <li>• Table 5, Miscellaneous equipment and tools</li> </ul>

Revision	Date	Description
		<ul style="list-style-type: none"> <li>◦ The equipment/tool required for the magnet mechanical interface drawing was changed from IDW references to a cross-reference to the clearance dimensions, since IDW files are only available in MyWorkshop.</li> <li>◦ Clarification was added to show that the level lengths shown represent two different levels.</li> <li>• In section 2.4, Handling the magnet in transit with a crane, former steps 6.4.1 and 6.4.2 were combined into a single step 1, and updated for clarity.</li> <li>• In section 2.7, Removing the shipping crate, steps 1 and 2 were added. Step 14 (formerly step 6.7.4.a) was updated to provide instruction for two different hardware removal methods; previously the step only stated how to remove lag screws securing the magnet through orange lifting beams.</li> <li>• In section 2.10, Lifting the magnet with a crane through the opening in the exterior wall, steps 5 and 6 were added to explain actually lifting and moving the magnet.</li> <li>• Chapter 7, Magnet Storage Conditions, was renamed to Chapter 3, Magnet storage conditions, pending ramp.</li> <li>• In section 3.1, Connecting the magnet to the compressor, step 1 (formerly step 7.1.1.a) and step 4 (formerly steps 7.1.3 to 7.1.5) were updated to include the F50SH compressor unit.</li> <li>• Section 7.3.1, Inspect cables, was changed to step 1 in section 3.2, Connecting the magnet monitoring connections, (formerly 7.2, Magnet Monitoring Connections). This is a more appropriate location since the cables need to be inspected before they can be connected.</li> <li>• References to MM3 were removed from section 3.4, Monitoring the magnet (formerly section 7.4, Magnet Monitoring), since some systems use MM3 and some use MM4.</li> <li>• Chapter 8, In-Transit Service &amp; Magnet System Checks, was renamed to Chapter 4, Doing in-transit service and magnet system checks.</li> <li>• Section 4.1, Preparing to do an in-transit helium refill <ul style="list-style-type: none"> <li>◦ The Notice was updated to include the following statement, per Service Note DOC2355412: "Before you continue with an in-transit helium fill, make sure that the shipping crate is removed from the magnet."</li> <li>◦ A sentence, "The images below show in-transit plumbing configuration examples." and Note were added before the many plumbing images, for clarification.</li> <li>◦ Figure 27, Hardware/plug in bag secured to plumbing on plumbing assembly, and Figure 28, In-transit plumbing configuration, were updated to reflect current plumbing and configuration.</li> <li>◦ Figure 30, Domestic storage configuration, including shipping hose and placard, was updated to reflect current plumbing and configuration. This figure is only included in R and W/WB series outputs.</li> <li>◦ Steps were added describing how to disconnect the shipping hose for helium boil off reduction if you want to connect a pressure measuring device for an in-transit liq-</li> </ul> </li> </ul>

Revision	Date	Description
		<p>uid helium fill, per SN_DOC1843537_Magnet_Helium_Shipping_Hose_R_W_WB.</p> <ul style="list-style-type: none"> <li>• In section 4.2, Doing a magnet system check, the note in step 4 (formerly step 8.1.3) about frost on the vertical penetration now only appears in R and W/WB series outputs.</li> <li>• Chapter 5, Preparing the scan room, was added. <ul style="list-style-type: none"> <li>◦ Steps 9.1.1 and 9.2.2, which were identical, were moved to this chapter as step 1.</li> <li>◦ Steps 9.1.2 and 9.2.3, which were identical, were moved to this chapter as step 2.</li> <li>◦ The Caution and Notice at the beginning of former Chapter 9, VibroAcoustic Damping Mat Placement, were moved to this chapter. The Note about mats that arrive in a cold state was moved to this chapter as step 3 with a Note.</li> </ul> </li> <li>• Chapters 9, VibroAcoustic Damping Mat Placement; 10, Moving Magnet to MR Suite; and 11, Magnet Leveling, Foot Shimming &amp; Bolt-Down were restructured into two chapters - Chapter 6, Installing a nonseismic vibroacoustic damping mat and leveling the magnet, and Chapter 7, Installing a seismic vibroacoustic damping mat and leveling the magnet. This restructuring helps clarify the exact steps a Field Engineer needs to follow and in what order for each type of vibroacoustic mat.</li> <li>• The introductory paragraph; Equipment &amp; Tools table; and Magnet Leveling Kit, 46-260888G4 table, formerly in Chapter 11, Magnet Leveling, Foot Shimming &amp; Bolt-Down, were moved to Sections 6.1 and 7.1, Equipment overview.</li> <li>• In sections 6.4 and 7.5, Preparing to move the magnet, a Note was added before the steps about removing the lifting rails and bubble wrap.</li> <li>• In sections 6.6 and 7.7, Lowering the magnet into position, step 1 was added about removing bubble wrap.</li> <li>• Section 7.4, Seismic mounting of a vibroacoustic damping mat to the floor, was added.</li> <li>• In the following sections the figure, Shim arrangement for gap fill, and associated step text were updated to include a second option applicable to SV vibroacoustic damping mats: <ul style="list-style-type: none"> <li>◦ 6.7, Adding leveling shims</li> <li>◦ 6.9, Anchoring the magnet and securing the shim material</li> <li>◦ 7.8, Adding leveling shims</li> <li>◦ 7.10, Anchoring the magnet and securing the shim material</li> </ul> </li> <li>• Appendix B, Vibroacoustic damping mat wall chart, was updated to include SIGNA Premier and Mulan W.</li> <li>• Appendix C, <i>Preinstallation Manual</i> reference, was added. Mentions of the PIM throughout this manual now include a cross-reference to this appendix.</li> </ul>

Page intentionally left blank



