

# **TEAL Electronics Corporation**

Model Isotran LM

TEAL Part Number 3550015-01

# TABLE OF CONTENTS

<b>SPECIFICATIONS .....</b>	<b>ii</b>
<b>1- SAFETY .....</b>	<b>1</b>
<b>2 - PRODUCT DESCRIPTION .....</b>	<b>2</b>
2-1 Product.....	2
2-2 Grounding .....	2
2-3 Additional Features.....	3
<b>3- PHYSICAL INSTALLATION.....</b>	<b>4</b>
3-1 Unpacking .....	4
3-2 Shipping Brackets.....	4
3-3 Mounting .....	4
<b>4- CONNECTIONS .....</b>	<b>5</b>
4-1 <u>Line</u> .....	5
4-2 <u>Load</u> .....	5
4-3 Voltage Adjustment .....	6
4-4 Circuit Breaker Configuration Settings .....	7
<b>5- MAINTENANCE .....</b>	<b>8</b>
5-1 Indicator Lamp Replacement .....	8
5-2 Fuse Replacement .....	8
<b>6- REVISION HISTORY.....</b>	<b>9</b>
<b>7- DRAWINGS</b>	
Dimension Diagram	
Component Locations	
Schematics	
Voltage Selection	

## SPECIFICATIONS

COMMON SPECIFICATIONS	ALL MODEL NUMBERS
<i>Input Voltage</i>	200/208/240/380/400/415/440/460/480/500 Volts DELTA
<i>Input Current</i>	60/57/50/31/30/29/27/26/25/24 A Respectively
<i>Frequency</i>	50/60 Hertz
<i>Output Voltage</i>	277/480 Volts WYE
<i>Construction Materials</i>	All transformer wires are insulated with Haptz Class H materials. Windings are insulated with a Nomex paper insulation system before vacuum varnishing. Internal wiring is minimum 200 degree C rated and sleeved with Class H material. A grain-oriented silicon iron core with 14-mil laminations interleaved 1-1 is used to minimize eddy currents and to keep external magnetic fields below 0.1 oersted (measured at 12 inches from unit in any direction).
INDIVIDUAL SPECIFICATIONS	MODEL NUMBERS
<i>Model Number</i>	Isotran LM
<i>(TEAL) Part Number</i>	3550015-01
<i>Power Rating</i>	100 KVA(I)
<i>Overload Protection</i>	175Amps
<i>Load Current</i>	42Amps
<i>Weight Pounds (Kg.)</i>	603lbs. (274 Kg.)
<i>Transfer Impedance 60 Hz (L- N)</i>	< 0.06 Ω
<i>Efficiency Percent</i>	97%
<i>Load Regulation (0-100% Load)</i>	2.5%
<i>Heat Loss (BTU/Hr.)</i>	< 2210
<i>Operating Temperature</i>	0C - +40C
<i>Storage Temperature</i>	-40C - +85C
<i>Humidity (non-condensing)</i>	10% - 90%

## 1- SAFETY

Even when an EPO/EMO switch is present this does not guarantee that the power has been cut off coming into the unit. To avoid tipping over, do not tip beyond 10° from vertical and avoid abrupt movements. Units are heavy. Ensure adequate lifting capacity is used.



---

High voltage. Turn power off before servicing.



---

Electrical shock hazard. Lock out power at main panel. Failure to do so could result in serious injury or death.



---

Failure to set transformer input taps to match nominal input voltage may result in improper output voltages which may damage equipment, cause load equipment to malfunction or cause injury.



---

Failure to set control transformer to match nominal input voltage may result in equipment damage or malfunction of equipment.



---

Power conditioner must be properly grounded for safety per National Electric Code, State or Local code.

## 2 - PRODUCT DESCRIPTION

### 2-1 Product

The power conditioner consists of a very well insulated, well shielded, low impedance isolation transformer. This provides protection against "common mode" noise and spikes (neutral-ground potentials). The system can withstand and protect against impulses up to 6000 volts. It can also provide the inrush and peak currents required by disk drives and modern switch mode power supplies in today's computer systems.

This power conditioner removes noise and spikes from the AC power line. It is installed between the source of power (such as a wall outlet) and the equipment that needs protection from power lines disturbances.

Clean power enhances the reliability and mean time between failure of computers and other sensitive electronic equipment. Depending upon the type of system being protected, cleaner power can for example, enhance testing sensitivity, testing yields, or image quality.

### 2-2 Grounding

*Good grounding and ground bonding are critical to the reliable operation of electronic systems as well as personnel safety. The following directions should be followed only in as far as they are consistent with all local and national electrical codes. Grounding can often be confusing and difficult. Contact TEAL Electronics at 858-558-9000 if you wish more specific advice.*

**This power conditioner includes an isolation transformer** that can significantly improve the quality of system grounding. By re-referencing the phase conductors to ground, it eliminates incoming line-side "common mode" noise (and complies with Article 250-5 of the NEC). The output neutral (if present) is bonded to ground.

**Input service ground requirements:** If all communicating system components are powered from this single point ground with isolated ground-type distribution, the system is then completely isolated from external ground quality issues. Non-isolated code minimum input grounds can then be used. Verify input grounding meets codes prior to installation.

**If the system has non-isolated communications lines** from other devices not powered by the conditioner, the system is then less isolated and incoming ground quality becomes more important. The communications line becomes a "back door" through which power and grounding problems can disrupt or damage the system. Good grounding of devices on both ends of the line helps minimize potential problems, as would surge suppressors on the communications line or a power conditioner on the device on the other end. Surge suppressors on the device, however, hurt much more than they help. Isolation of the communications line (optical or magnetic) eliminates this problem altogether.

**If a "good" input ground is required**, it should be a continuous, insulated, isolated, oversized wire back to the service entrance. This wire for the TEAL power conditioner refers to the ground wire in a 4-wire DELTA installation, installed with the 3 phase wires. The Federal Information Processing Standards Publication 94 (9/21/83) also known as "FIPS Pub 94" is an excellent reference guide. It defines a "good ground" as one with low impedance over a wide spectrum of high frequencies. It also says that optimum equipment performance and personnel safety can be achieved by tying all communicating system components to a single point ground (or, in the case of a large room, create a "ground reference plane" that acts as a single point).

**Local Grounding Bond:** Article 250-30 of the National Electric Code (NEC) requires that hard wired power conditioners be bonded to nearest available local building grounding electrode as well as the equipment ground. The required local ground bond points are:

- a. Building Steel, or
- b. Grounded metal water pipe **if** building steel is not available, or
- c. Other types of electrodes per NEC 250-50 and 250-52 **if** building steel or grounded metal water pipe is not available.

This also helps reduce electrical noise issues by referencing the system to local ground potential in case parts of the system might be touching grounded parts.

**Isolated output grounding:** Except at the single local ground point at the power conditioner, it is important that the output ground from the power conditioner be kept isolated from building ground in any output wiring. If receptacles are hard wired to the power conditioner in the field, isolated ground receptacles must be used. These special receptacles avoid re-connecting the output ground to the conduit, and because they look different they reduce the chance of non-critical loads being inadvertently plugged into the conditioned power.

## **2-3 Additional Features**

A customer supplied, normally opened external EPO switch may be installed at the EPO terminal block (refer to Schematic).

## 3- PHYSICAL INSTALLATION

### 3-1 Unpacking

- Protect finish, light, extended handles and buttons from damage while uncrating and placement.
- If forklift is used, lift only by frame, avoiding damage to sheet metal covers. Avoid hitting casters with fork-lift forks when taking off pallet. If there is a removable door remove it while uncrating and during placement to avoid damage to hinges and latches.

If there is external damage or if internal components “rattle”, do not apply voltage. Check for any loose components or connections, call TEAL Tech Support for assistance.

All units are carefully and adequately packed. Please retain packing materials until the unit is satisfactorily install and accepted.

Damage in transit is always possible. Visible external damage should be noted on the bill of lading upon receipt and a claim filed with the shipper. Concealed damage can also be claimed with the shipper within 15 days. Contact TEAL if you wish assistance in filing your claim.

Each unit is inspected and tested before it leaves the factory. An individual check-out sheet is maintained on file by TEAL and retrievable by power size and serial number. Items tested include voltages input/output, current, and spike attenuation both normal and common mode. All connections are tight when they leave the factory.

### 3-2 Shipping Brackets

The shipping brackets used with this unit were designed to be utilized when mounting the unit to the floor.

### 3-3 Mounting

Refer to the attached mechanical drawing for dimensional information. The unit should be mounted in a dry location. Conduit entrances are made through the rear of the unit.



---

HIGH VOLTAGE. Turn power off before removing cover.

---

If the unit is mounted on a raised floor (such as a computer room floor) provisions must be made to support the weight of the unit.

Because the TEAL power conditioner is designed to operate at a high efficiency, a minimum amount of ventilation is required for proper operation. However, one should not block the vents at the top of the unit and always allow at least one inch around the unit for natural convection to take place.

## 4- CONNECTIONS

It is generally desirable to have all communicating system components (e.g. CPU, printer, terminal, modem) powered from the same “clean” source and the same ground point. That means they should all be connected to the same conditioner (which should have been correctly sized to handle the total load). Call TEAL Tech Support if you need advice on these connections.

Check the labels on the conditioner to make sure that the input and output voltages and currents match the system’s requirements. If there are any questions, please call TEAL or your local representative.

### 4-1 Line

The conditioner is connected through a circuit breaker. Input connections are made to the Input circuit breaker and output connections are made to the output terminal blocks. The circuit breaker lugs and terminal blocks are compression type, so no special hardware is required. Check to make sure that all leads and connections are well insulated. Recheck the tightness of all lugs, a loose connection may damage the unit and/or the load.

This unit has multiple input voltages that can be changed in the field. There should be a tag attached to the input circuit breaker specifying which input voltage tap has been selected at the factory. Check the voltage present to determine if it is correctly set. If not, refer to the “Voltage Adjustment “ Section 4-3 and “Voltage Selection” drawing for instructions.

Input Circuit Breaker Torque Spec: 150 in-lbs

### 4-2 Load

Once voltage has been applied to the conditioner, without a load connected, turn on the main input circuit breaker switch. There should be a soft hum and the switch should stay on. Using a volt meter, check the output for proper voltage. With no load, these voltages will often be a few percent higher than the input voltage (e.g. 280V for nominal 277V L-N circuit). This is to compensate for circuit losses when the load is connected.

If the voltages check out, turn on the loads individually. If the power conditioner is overloaded, the input circuit breaker will shut off. Otherwise, everything should operate normally.

Terminal Block Torque Spec:

TB1 – 325 in-lbs (27 ft-lbs)

TB2, TB3 and TB5 – 120 in-lbs (10 ft-lbs)

TB4 – 16 in-lbs

### 4-3 Voltage Adjustment

Some units are equipped with voltage adjustment taps to compensate for different voltages in different areas. Most industrial buildings have 120/208 volts, for example, but some have 240/415 volt power. Only qualified personnel may do this adjustment as it involves a high voltage electrical connection. Failure to make this adjustment will result in the wrong output voltage from the conditioner that could potentially harm the load.



**⚠ DANGER**



---

HIGH VOLTAGE. Turn power off before servicing.

---

Refer to the attached electrical schematic, and voltage selection drawings for information on taps available. Move the appropriate wires per the electrical schematic or voltage selection drawings. Then test output voltages before the load is connected.

#### Step-By-Step Checklist

- Retap the main transformer to the required voltage.
- Re-configure the input circuit breaker (if necessary).

**⚠ WARNING**

---

Ensure all electrical connections are tight. Loose connections are the most common failure point in this and all wiring systems.

---

## 4-4 Circuit Breaker Configuration Settings

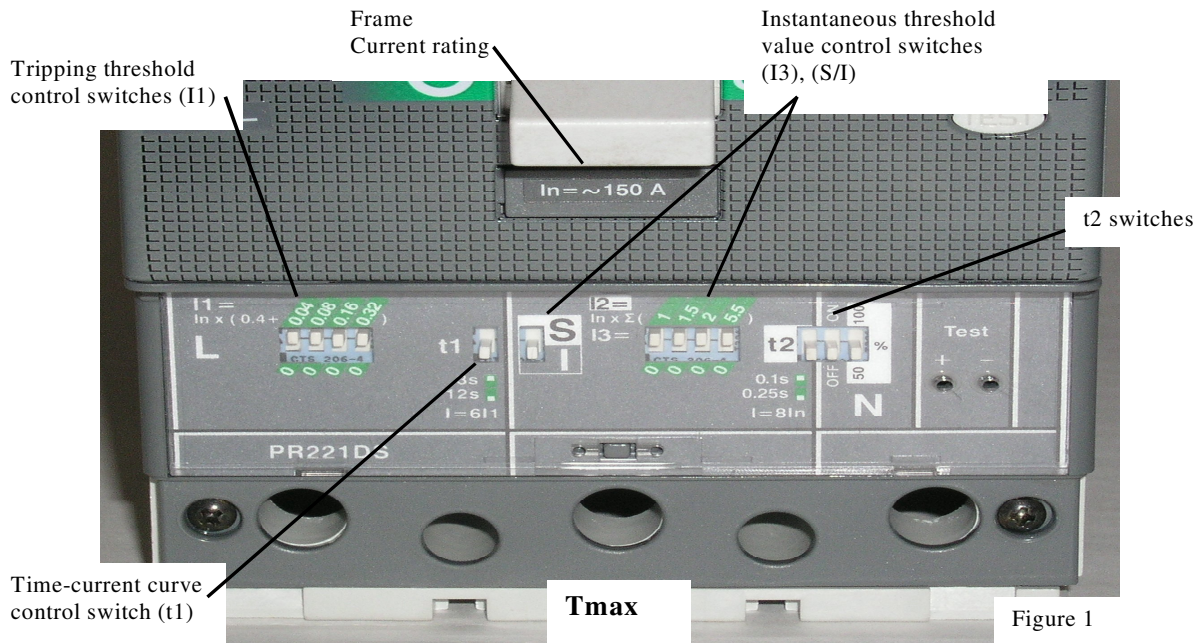

CIRCUIT BREAKER IMAGE SHOWN IS FOR REFERENCE ONLY.

Three dip-switches on the circuit breaker panel control the input voltage overload setting, the overload delay, and the short-circuit trip adjustment. Factory settings for the three switches are:

- I1 - set based on the input voltage. Refer to the Schematic for a table of the other I1 settings.
- t1 Switch / S/I switch – time current curve (set to D), both switches are in the down position
- I3 - largest multiple (set to 12), all four switched are in the up position.
- t2 – all three switches are in the down positions.

Use a small blade screwdriver to move the dip switch toggles to the appropriate settings.

## 5- MAINTENANCE

No maintenance is required other than periodically (i.e. every 6 months) all electrical connections should be checked for tightness. Any accumulations of dust or debris should be removed to keep ventilation working for convection cooling.

If it is determined that a component needs to be replaced, then follow the respective replacement procedure described below for the defective component.

### 5-1 Indicator Lamp Replacement

Replace indicator lamp as follows:

1. Unscrew the lens cap.
2. Replace the indicator lamp with a replacement lamp of the same type and rating.
3. Screw on the lens cap. All circuits should operate properly.

### 5-2 Fuse Replacement

Replace fuse F1 on the landing plate as follows:

1. Turn off the voltage to the unit.



---

**HIGH VOLTAGE.** Voltage will be present at the control circuit if voltage to the unit is not turned off.

---

2. Turn off the input circuit breaker. Open the front of the unit.
3. Remove fuse and test with continuity tester to determine it is defective.
4. Replace defective fuse only with fuse of the same size, rating and type.
5. Close the front of the unit.
6. Apply voltage to the unit.
7. Turn on the input circuit breaker. All circuits should operate properly.

## 6- REVISION HISTORY

Revision                    A0    New Release

Checked By:



Date:    07-27-06

Approved By:



Date:    07-27-06

Revision                    A1    Updated    CB    t2    switches    in    the  
schematics.

Approved By:



Date:    01-03-07

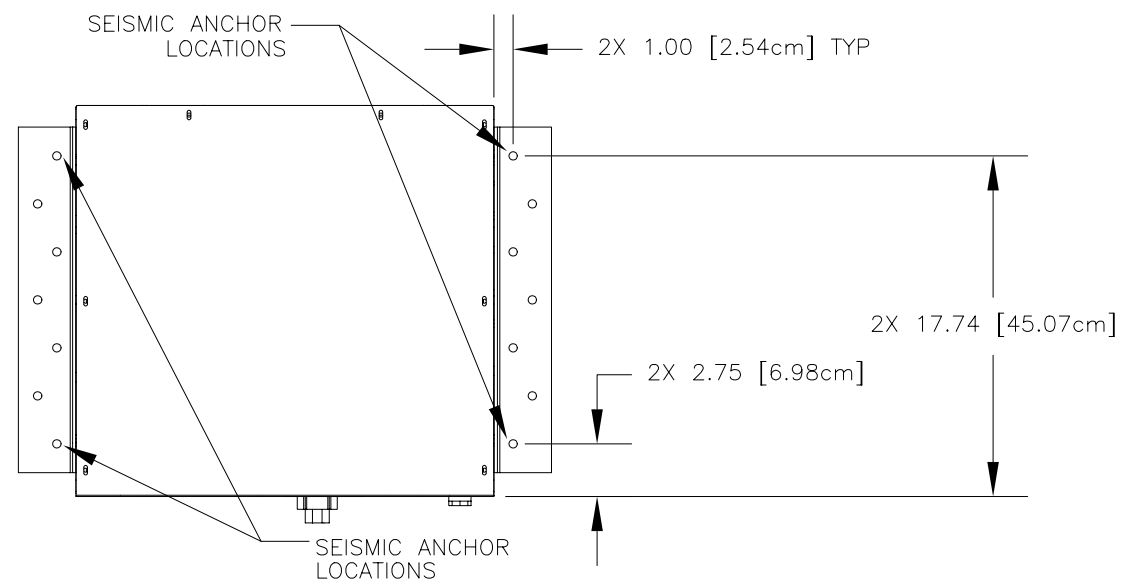

TOP VIEW

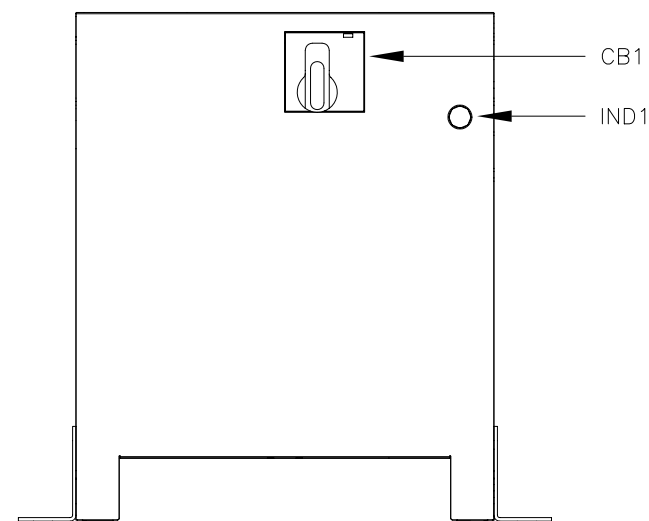

FRONT VIEW

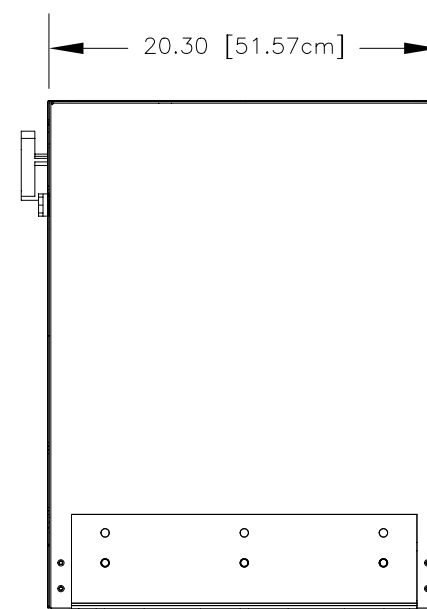

SIDE VIEW

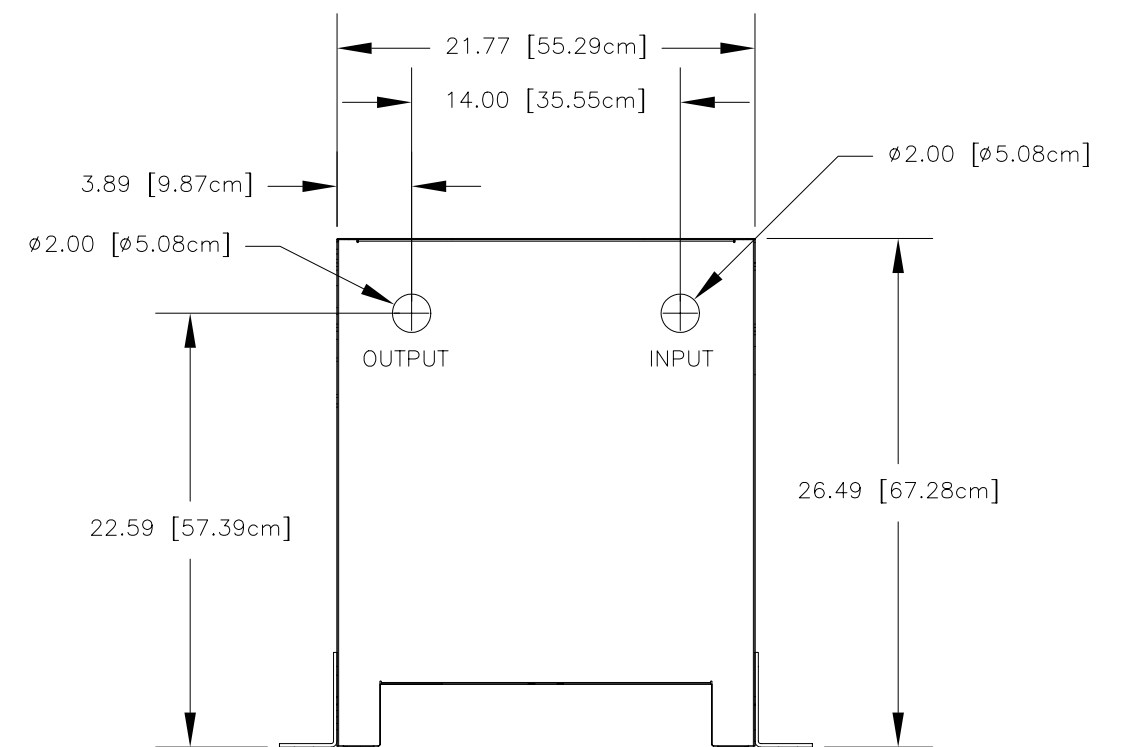

REAR VIEW

MFG NOTE: PRINTED DOCS MUST MATCH TRAVELER PART NUMBER AND REVISION. DISCARD AFTER WORK ORDER IS COMPLETED.

WORK ORDER:

WO REV:

INITIALS:

DATE:

<p>THIS DOCUMENT CONTAINS CONFIDENTIAL PROPRIETARY INFORMATION AND IS NOT TO BE DISTRIBUTED IN WHOLE OR IN PART WITHOUT THE WRITTEN PERMISSION OF TEAL ELECTRONICS CORPORATION.</p>	AO	7-28-06/EG	NEW RELEASE	8-1-06/IFA
	REVISION	DATE/BY	DESCRIPTION	APPROVED
	APPROVALS		DATE	<p>DIMENSION DIAGRAM ISOTRAN LM LINE MATCHING TRANSFORMER</p>
	DRAWN BY	EG	7/28/06	
CHECKED BY	T. DONALDSON	7-31-06	FILENAME	O:\Manuals\100\103\1030293\CommonFiles\1030293_D1_A0
APPROVED BY	F. ALI	8-1-06	SIZE	B
		SCALE (CAD Use Only)	PART NUMBER	DOC. REV
		NTS	1030293	AO
				SHEET
				D1

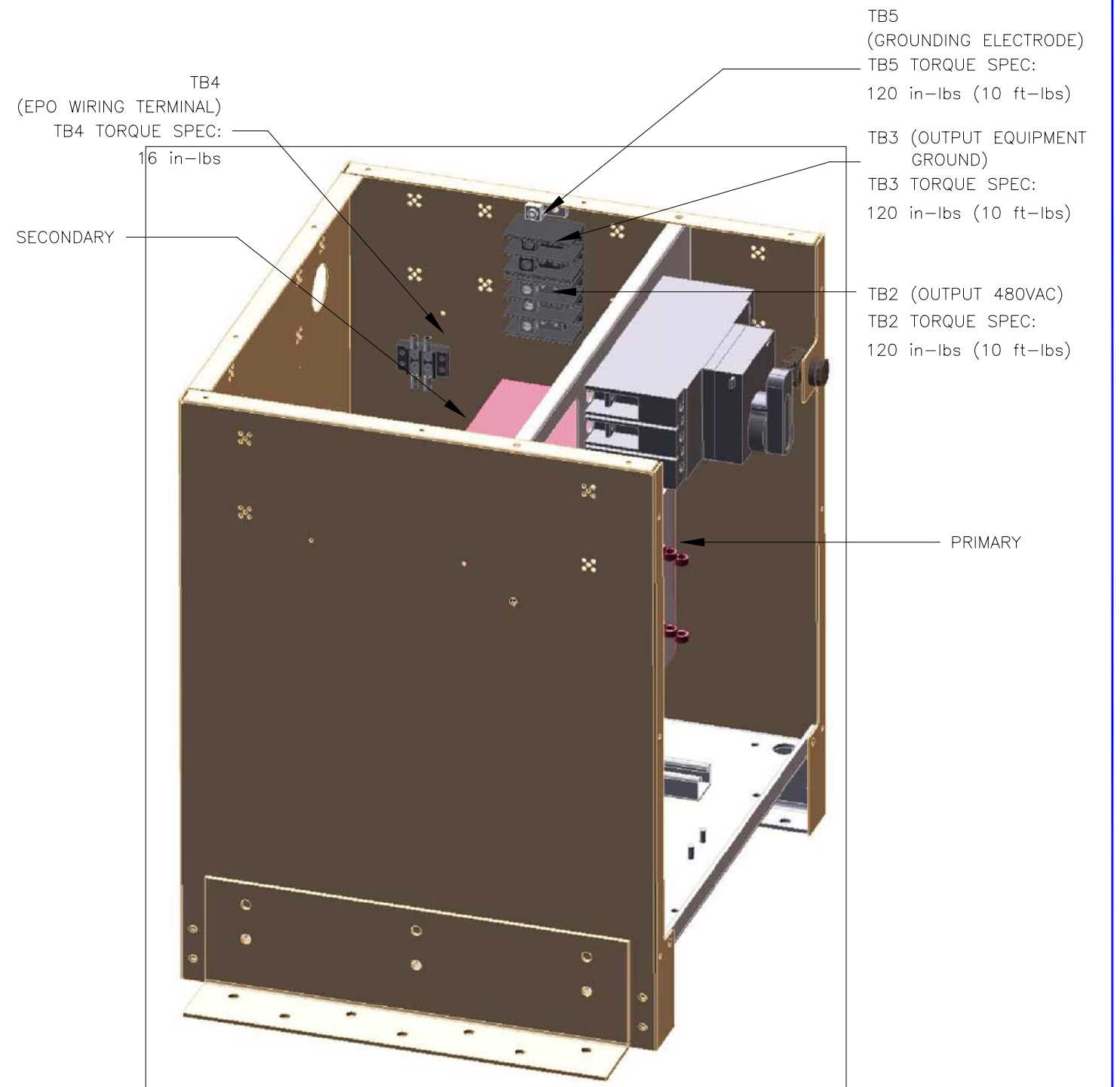
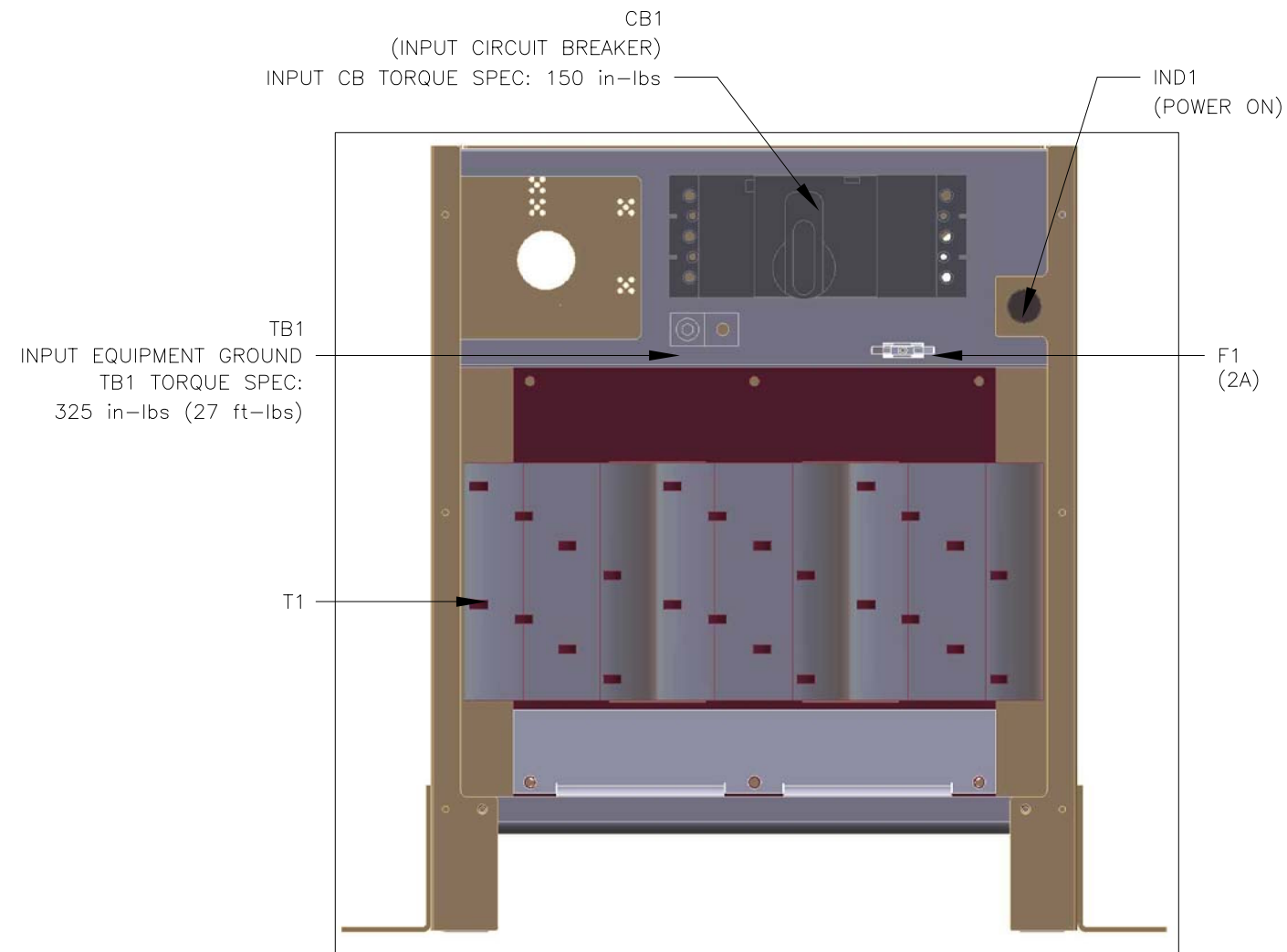

REVISION	DATE/BY	DESCRIPTION	APPROVED	
A0	8-1-06/tjd	Per ECO 4462, take to A0, no changes required	8-01-06/FA	
XO	5-19-06/EG	SIMILAR TO 3550015. ECO 4366.	8-01-06/FA	
APPROVALS		DATE	ASSEMBLY VIEW	
DRAWN BY EG		5-19-06		
CHECKED BY G. SANNER		3/29/04		
APPROVED BY F.Aii		06/13/06		
FILENAME	SIZE	SCALE (CAD Use Only)	PART NUMBER	DOC. REV
O:\FinishedGoods\300\355\3550015-01\CommonFiles\3550015-01_D1_A0	B	NTS	3550015-01	A0
			SHEET	D1



THIS DOCUMENT CONTAINS CONFIDENTIAL PROPRIETARY INFORMATION AND IS NOT TO BE DISTRIBUTED IN WHOLE OR IN PART WITHOUT THE WRITTEN PERMISSION OF TEAL ELECTRONICS CORPORATION.

MFG NOTE: PRINTED DOCS MUST MATCH TRAVELER PART NUMBER AND REVISION. DISCARD AFTER WORK ORDER IS COMPLETED.

WORK ORDER:

WO REV:

INITIALS:

DATE:

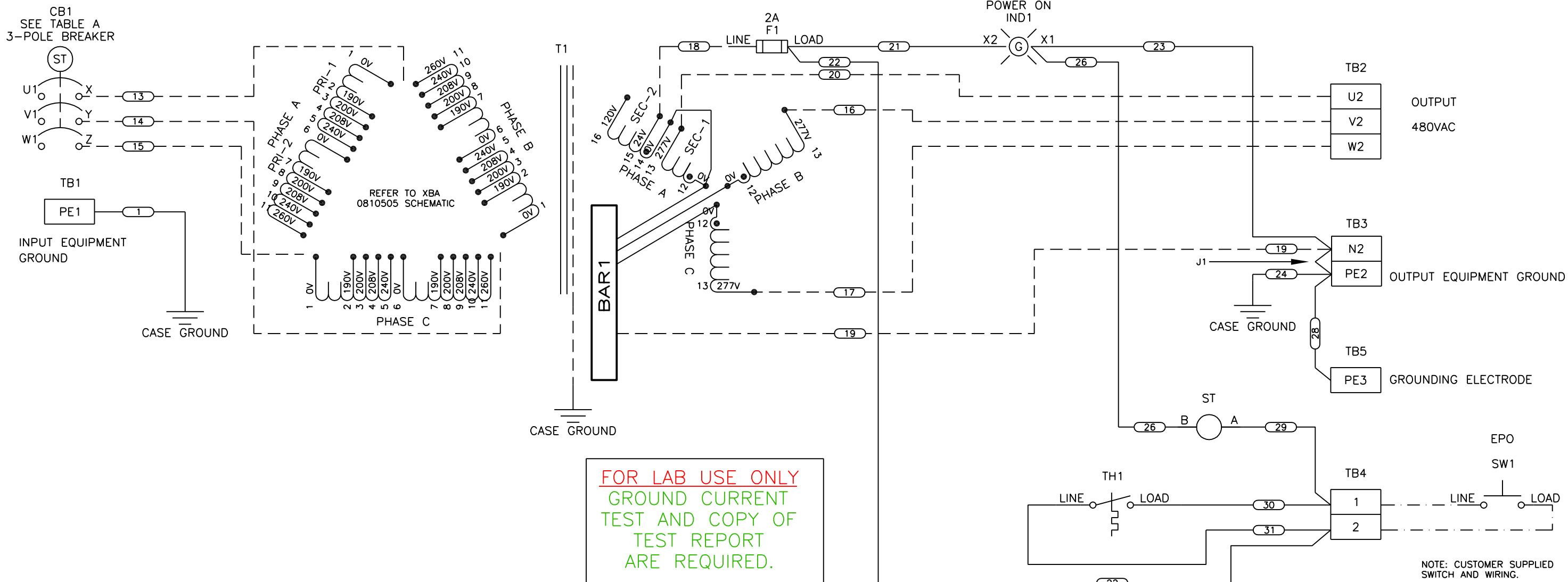

- CUSTOMER NOTES:
1. REFER TO VOLTAGE SELECTION PAGE V1.
  2. CB1 WIRE RANGE #6 - 350 MCM.
  3. TB1 WIRE RANGE #6 - 350 MCM.
  4. TB2-TB3 WIRE RANGE #14AWG - 2/0.
  5. TB4 WIRE RANGE #12 - #14AWG.
  6. TB5 WIRE RANGE #6AWG - 2/0.

- PRODUCTION NOTES:
1. REFER TO XBA SCHEMATIC FOR INPUT VOLTAGE WIRE CONFIGURATIONS.
  2. DASHED LINES DENOTES WIRES FROM XBA.
  3. WIRE NUMBERS 2, 3 NOT USED.
  4. DASH DOT DASH LINES DENOTE CUSTOMER SUPPLIED WIRES.

TABLE A

VOLTAGES	INPUT VOLTAGES										SETTINGS FOR:			
	200	208	240	380	400	415	440	460	480	500	t1	S/I	I3	t2
250 AMP FRAME SIZE	170	170	170	150	150	150	125	125	125	125	-	-	-	-
SET POINTS	0.68	0.68	0.68	0.6	0.6	0.6	0.48	0.48	0.48	0.48	-	-	-	-
L SWITCH SETTINGS	-	-	-	-	-	-	-	-	-	-	-	-	-	-

**WARNING!** HIGH VOLTAGES PRESENT INSIDE UNIT, TO BE OPENED ONLY BY QUALIFIED PERSONNEL

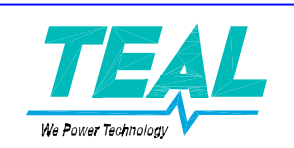

THIS DOCUMENT CONTAINS CONFIDENTIAL PROPRIETARY INFORMATION AND IS NOT TO BE DISTRIBUTED IN WHOLE OR IN PART WITHOUT THE WRITTEN PERMISSION OF TEAL ELECTRONICS CORPORATION.

REVISION	DATE/BY	DESCRIPTION	APPROVED
A1	1-3-07/EBG	CORRECTED CB t2 SWITCHES TO 3, ECR 06277.	FA/01-03-07
A0	8-1-06/jd	Per ECO 4462, take to A0, no changes required	8-01-06/FA
X0	5-19-06	SIMILAR TO 3550015. ECO 4366	8-01-06/FA

APPROVALS	DATE	<b>MAIN SCHEMATIC</b>		
DRAWN BY EG	5-19-06			
CHECKED BY G. SANNER	3/29/04			
APPROVED BY F.Ai	06/13/06			
FILENAME O:\FinishedGoods\300\355\3550015-01\CommanFiles\3550015-01_S1_A1	SIZE B	SCALE (CAD Use Only) NTS	PART NUMBER 3550015-01	DOC. REV A1
SHEET			S1	

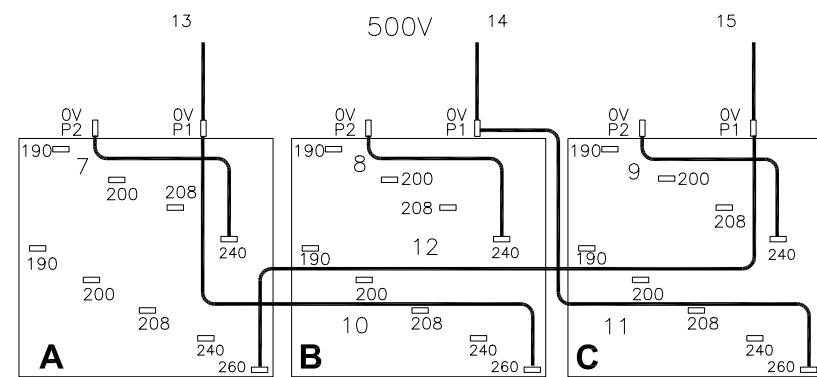
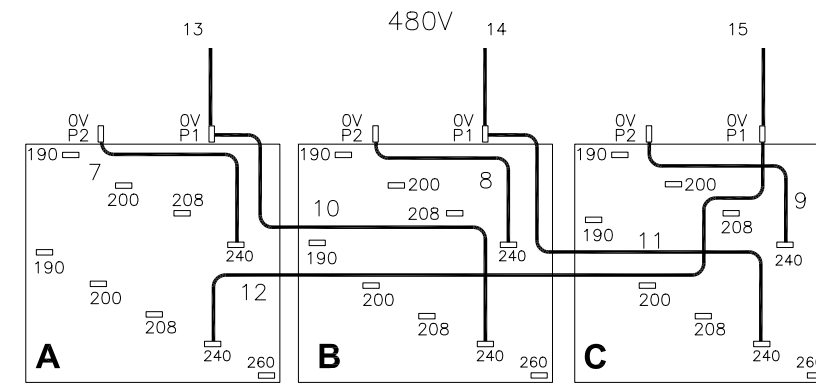
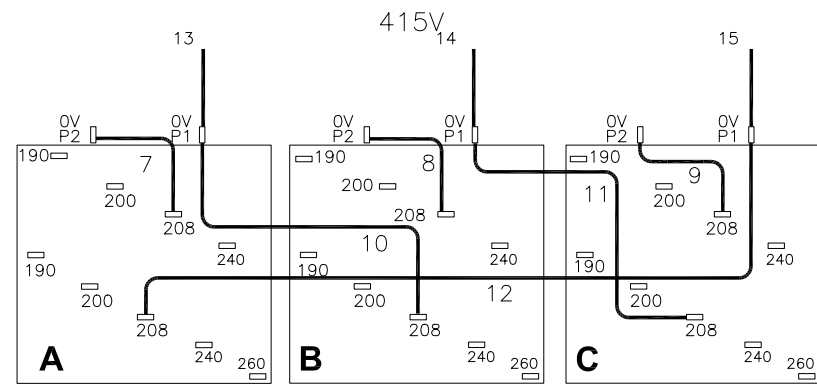
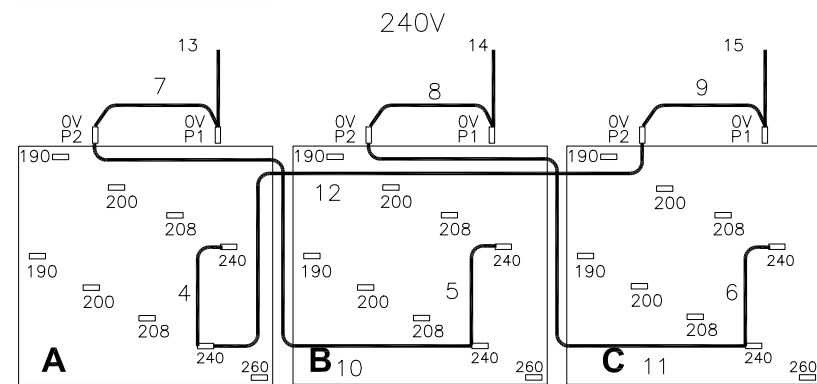
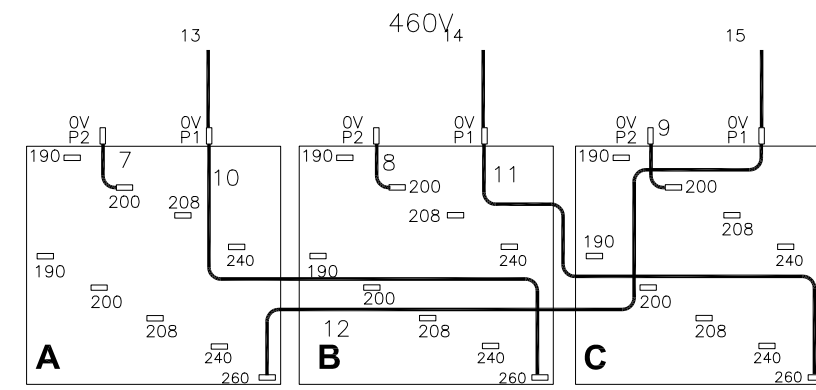
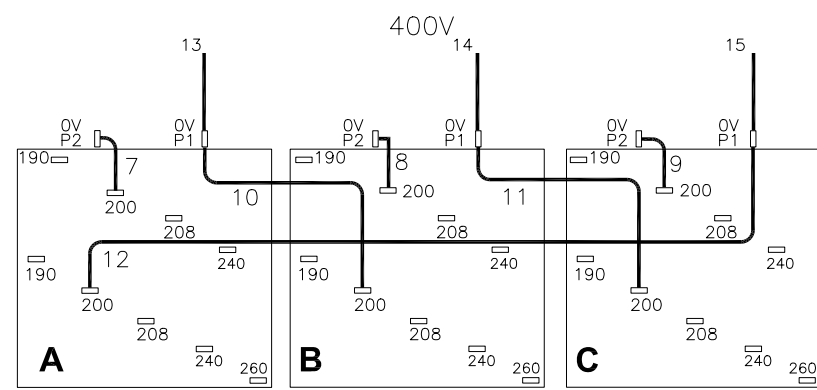
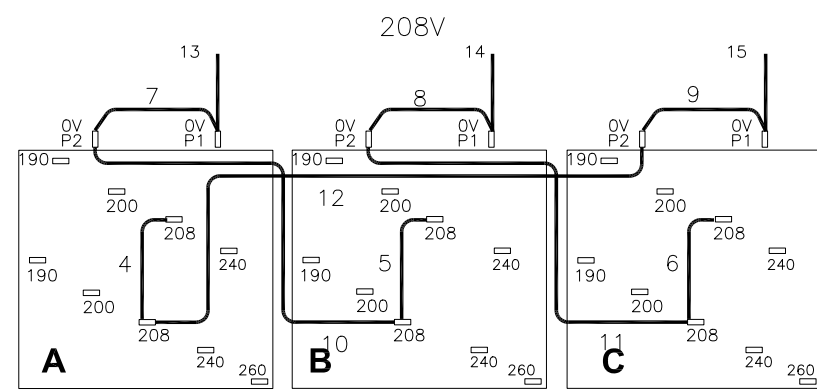
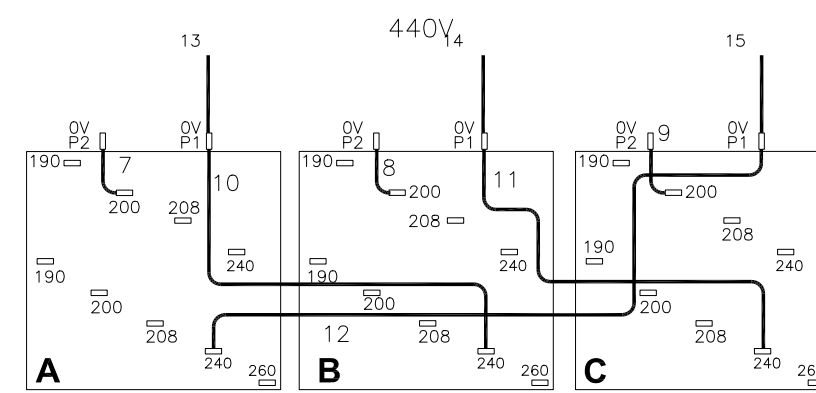
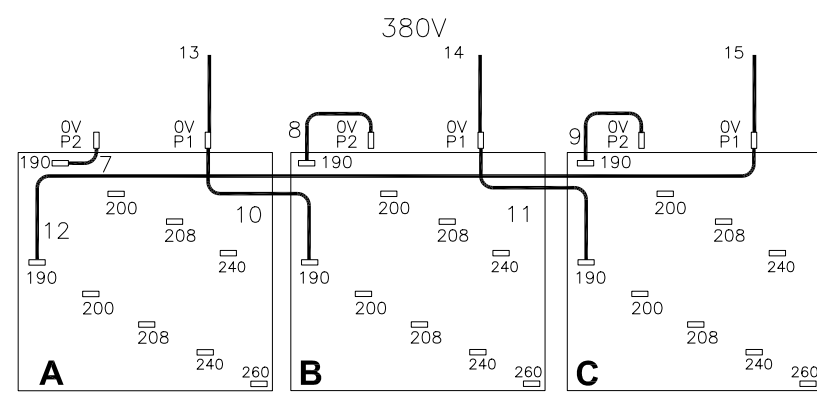
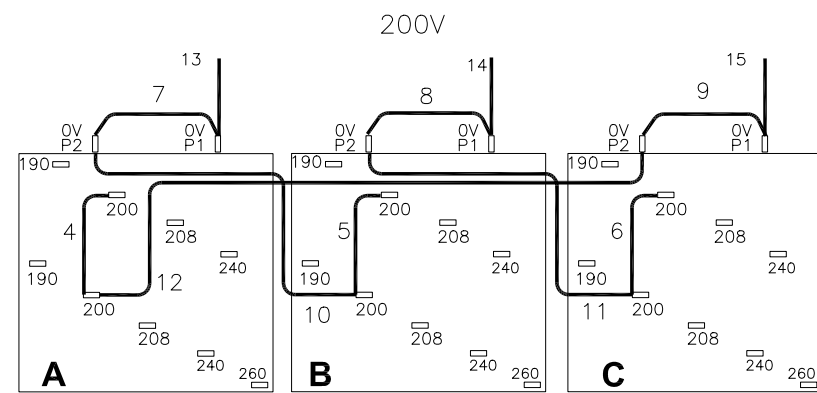

NOTE:

1. WHEN WIRED FOR 380V-500V, WIRES 4-6 MUST BE ASSEMBLED AND SHIPPED LOOSE WITH THE UNIT.

	AO	2-10-05	NEW RELEASE. CLONED FROM 0810505 (3960)	TC 2-10-05
	REVISION	DATE/BY	DESCRIPTION	APPROVED
APPROVALS		DATE		
DRAWN BY		3-4-04		
CHECKED BY		3/29/04		
APPROVED BY		2-10-05		
FILENAME		SHEET		
THIS DOCUMENT CONTAINS CONFIDENTIAL PROPRIETARY INFORMATION AND IS NOT TO BE DISTRIBUTED IN WHOLE OR IN PART WITHOUT THE WRITTEN PERMISSION OF TEAL ELECTRONICS CORPORATION.		SIZE	SCALE (CAD Use Only)	PART NUMBER
		B	NTS	0810560
				DOC. REV
				AO
				V1

MFG NOTE: PRINTED DOCS MUST MATCH TRAVELER PART NUMBER AND REVISION. DISCARD AFTER WORK ORDER IS COMPLETED.

WORK ORDER:

WO REV:

INITIALS:

DATE:

# TEAL TWO YEAR WARRANTY

*TEAL Electronics Corporation* warrants its Power Subsystems to be free from defects in the materials and workmanship for a period of two (2) years from the date of shipment. *TEAL's* obligation for breach of warranty is limited to the repair or replacement at *TEAL's* option, at the factory without charge to the customer when returned prepaid within the warranty period. Warranty is void on units that have been subject to misuse, neglect, accident, or that have been subject to repair or modification by persons not authorized by *TEAL*.

The forgoing constitutes the sole and exclusive remedy of the purchaser and liability of *TEAL*, and is in lieu of all other warranties expressed or implied, *TEAL* makes no other warranty except as expressly stated above, including without limitation any warranty of merchantability or fitness for a particular purpose. In no event shall *TEAL* be liable for direct, incidental, special or consequential damages.

