



MANUAL NUMBER: CD32ZZ-269F

DATE: November 11 / 2011

TECHNICAL INSTRUCTION

(Original Instruction)

F-50HC COMPRESSOR UNIT

For Service Personnel Only

Sumitomo Heavy Industries, Ltd.
Cryogenics Division

**2-1-1 Yato-cho, Nishitokyo-City,
Tokyo 188-8585, Japan**

E-mail: cryo@shi.co.jp
URL: <http://www.shicryogenics.com>

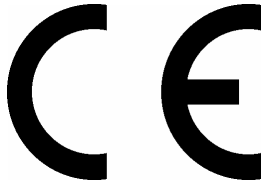

EC DECLARATION OF CONFORMITY

We, Sumitomo Heavy Industries, Ltd., declare herewith that the Compressor Unit (component of Closed Cycle Cryogenic Refrigeration System) listed below, on the basis of its design and engineering as well as in the embodiment which we have placed on the market, comply with the applicable safety and health requirements set forth in EC directives.

This declaration becomes invalid if modifications are made to the product without consultation with us.

Designation of the Compressor Unit model;
F-50H, F-50HC, F-50HS,

The products comply with the following council directives;

- > Machinery Directive (2006/42/EC)
- > EMC Directive (2004/108/EC)

Applicable standards;

- > EN 60204-1: 2006
- > EN 55011: 2007, +A2:2007
- > EN 61000-3-2: 2006
- > EN 61000-3-3: 1995, +A1 :2001,
+A2 :2005
- > EN 61000-6-2: 2005

Tokyo, 20 May / 2011
Tosiharu Tanaka,
General Manager, Cryogenics Division

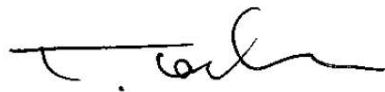

*Sumitomo Heavy Industries, Ltd.
Cryogenics Division
Precision Equipment Group*

2-1-1, YATO-CHO, NISHITOKYO-CITY, TOKYO 188-8585, JAPAN

TABLE OF CONTENTS

SECTION	ITEM	PAGE No.
	CROSS REFERANCE	1
1	GENERAL INFORMATION	2
1-1	SPECIFICATIONS	2
1-2	CONSTRUCTION	6
1-2-1	CONTROLS AND COUPLINGS	6
1-2-2	GAS AND OIL FLOW IN THE COMPRESSOR UNIT	9
1-2-3	INTERNAL COMPONENTS	11
1-3	ELECTRICAL DESCRIPTION	13
1-3-1	DIAGNOSTIC INTERFACE	13
1-3-2	SAFETY DEVICES	14
2	INSTALLATION	15
2-1	SITE REQUIREMENT	17
2-2	INPUT POWER VOLTAGE SETTING	19
2-3	INPUT POWER CABLE CONNECTION	22
3	GAS BY PASS OPERATION	24
3-1	GAS BY PASS OPERATION	24
3-2	SPECIFICATIONS	24
3-3	INSTALLATION	25
4	MAINTENANCE	26
4-1	PERIODICAL MAINTENANCE	27
4-1-1	REPLACEMENT OF THE COMPRESSOR ADSORBER	28
4-1-2	RESET THE CIRCUIT PROTECTOR(S)	33
	APPENDIX	34
	ELECTRICAL SCHEMATIC	
	DRAWINGS	
	REVISION CONTROL	

CROSS REFERENCE

Thoroughly read this manual and following manuals before using this equipment.

MANUAL NAME	MANUAL No.
OPERATION MANUAL SRDK Series CRYOCOOLER	CD32ZZ-268
TECHNICAL INSTRUCTION RDK Series 4K COLD HEAD	CD32ZZ-209 (266937A)

1 GENERAL INFORMATION

1-1 SPECIFICATIONS

The specifications of F-50HC Helium Compressor Unit are summarized in Table 1.1.

Table 1.1 F-50HC COMPRESSOR UNIT SPECIFICATION

	for RDK-408C2, 415C2
Dimension	
Width	450 mm
Length	485 mm
Height	591 mm
Helium Gas Pressure	
Static	1.60 - 1.65 MPa at 20 deg.C
Operating (High Side)** (Reference)	1.90 - 2.20 MPa --- approx.
Operating (Low Side) ** (Reference)	0.40 - 0.60 MPa --- approx.
Ambient Temperature Range	5 to 35 deg.C (28 to 35 deg.C with 5% Capacity Loss)
Humidity Range	25 to 85 %RH (without dew)
Mass	120 kg --- approx.
Electrical Requirement	
Power Line Voltage (+/-10%)	AC 380, 400, 415 V / 50 Hz, 3 phase (3W+PE) AC 460, 480 V / 60Hz, 3 phase (3W+PE) (Δground, Commercial Power Source) <u>“WARNING”</u> <u>Do not use inverter for the main power source.</u>
Operating Current	Max. 13 A (Both 50 and 60 Hz)
Starting Current	75/ 80 A (50/ 60 Hz)
Min. Circuit Ampacity	17 A
Max. Fuse or Circuit Breaker Size	30 A
Power Requirement	Minimum 9 kVA Recommended 12 kVA
Power Consumption	Max. 8.3 kW / Steady State 7.5kW at 60Hz Max. 7.2 kW / Steady State 6.5kW at 50Hz <u>See the ELECTRICAL SCHEMATIC of “APPENDIX” for detail.</u>
Cooling water requirement	<u>“CAUTION”</u> <u>Do not use the demineralized water for cooling water.</u>
Temperature Range	4 to 28 deg.C <u>See the Figure 1.1 and Table 1.2</u>
Flow Rate	7 to 10 liter/min at 28deg.C <u>See the Figure 1.1 and Table 1.2</u>
Quality	<u>See the Table 1.2</u>
Pressure Relief Valve Setting	2.61 - 2.75 MPa
Gas Supply Connector	1/2-inch Coupling
Gas Return Connector	1/2-inch Coupling

* Input Power Cable Terminal Cover is 103.0 mm. See the Figure 1.2.

** The operating pressure varies according to the heat load of cold head and temperature around the equipment.

COOLING WATER REQUIREMENT

The typical flow characteristics are shown in **Figure 1.1**, and cooling water requirement are shown in **Table 1.2**.

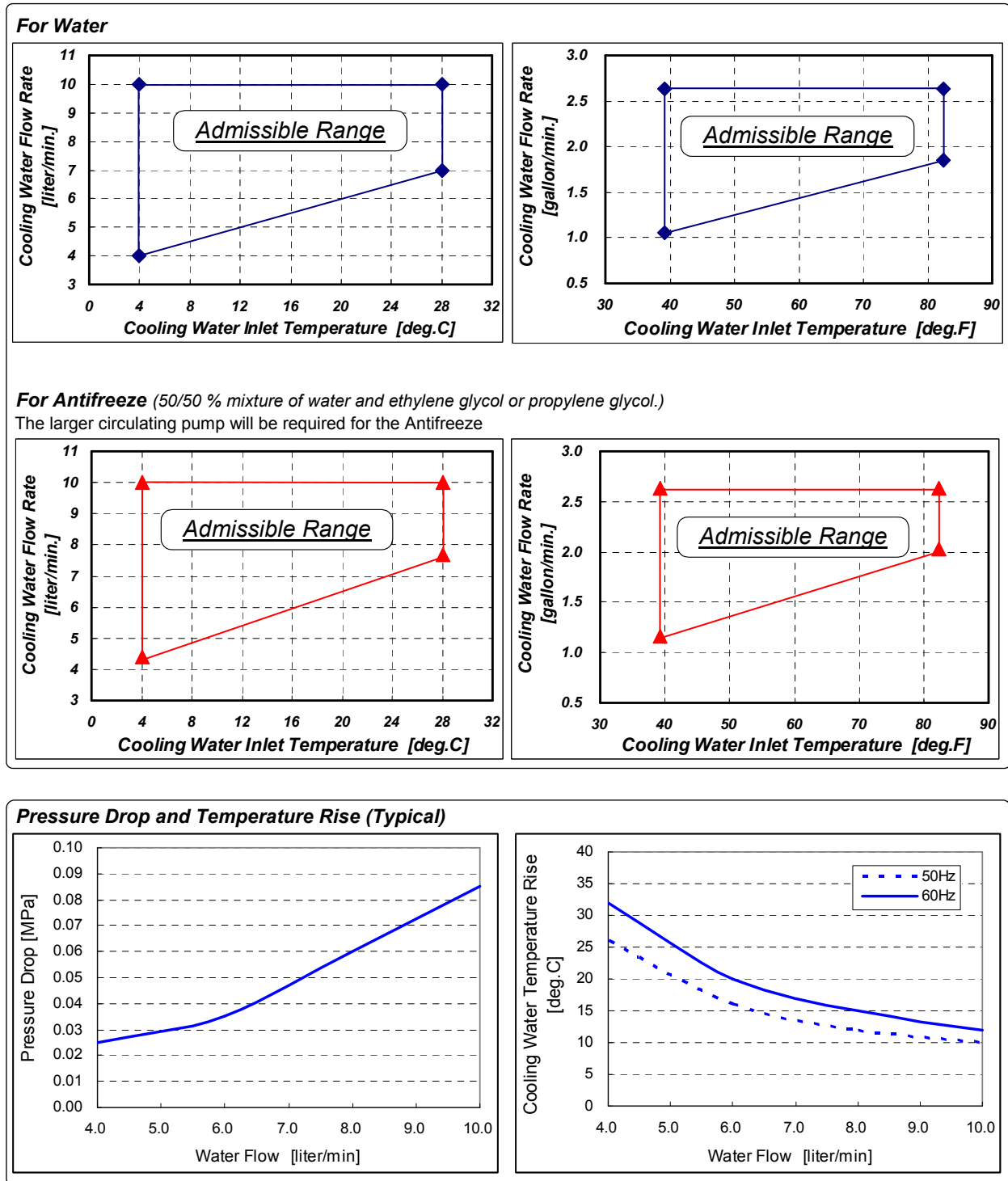
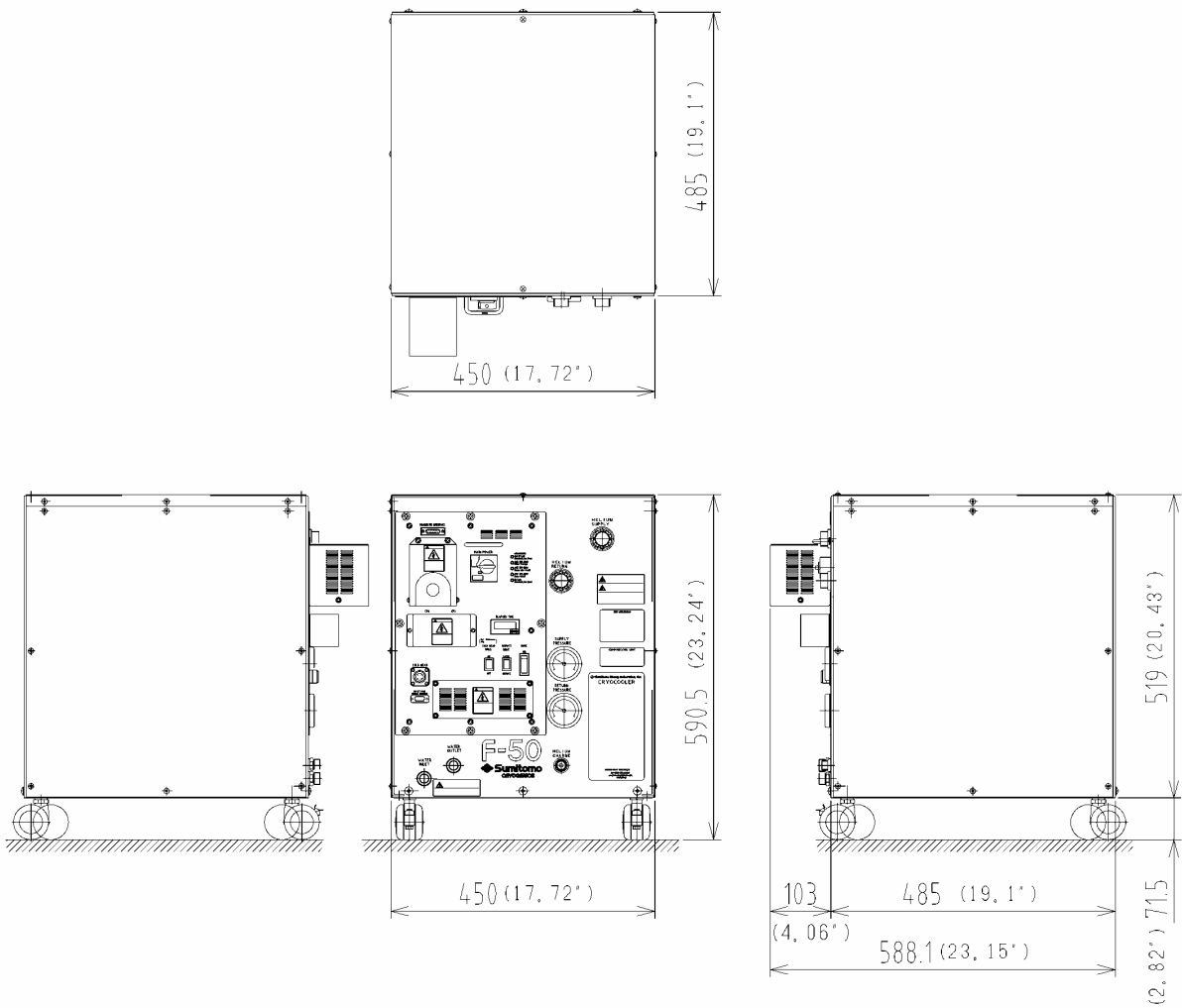

Figure 1.1 COOLING WATER TYPICAL FLOW CHARACTERISTICS

Table 1.2 COOLING WATER SPECIFICATIONS

CHARACTERISTICS	Inlet Temperature Range [deg.C]	[4.0 ~ 28.0]
	Inlet Pressure Range [MPa]	[0.10 ~ 0.69]
	Flow Rate [liter/min.]	[4.0 ~ 10.0]
	Pressure Drop [MPa]	[0.025 ~ 0.085]
	Heat Output [kW]	<Steady State> [< 6.5] for 50Hz [< 7.5] for 60Hz <Maximum> [< 7.2] for 50Hz [< 8.3] for 60Hz
QUALITY	pH Value	6.5 to 8.2 at 25 deg.C
	Electrical Conductivity	< 80 mS / m
	Chloride Ion	< 200 mg/liter
	Sulfate Ion	< 200 mg/liter
	M-Alkalinity	< 100 mg/liter
	Total Hardness	< 200 mg/liter
	Calcium Hardness	< 150 mg/liter
	Ionic Silica	< 50 mg/liter
	Iron	< 1.0 mg/liter
	Copper	< 0.3 mg/liter
	Sulfide Ion	None, Not detectable
	Ammonium ion	< 1.0 mg/liter
	Residual Chlorine	< 0.3 mg/liter
	Free Carbon Dioxide	< 4.0 mg/liter
	Stability Index	6.0 to 7.0
	Suspended Matter	< 10 mg/liter
Particle Size	< 100 μm	



XRE05B0243C0

Figure 1.2 OUTLINE VIEW FOR F-50HC COMPRESSOR UNIT

1-2 CONSTRUCTION

the outline view for F-50HC Compressor Unit is shown in **Figure 1.2**.

The function of the Compressor Unit is to supply high pressure He gas to the Cold Head and re-compress the returned He gas from the Cold Head. The Compressor Unit consists of the following major components: a Compressor Capsule, a Cooling system, Oil separation and injection system, and Adsorber.

1-2-1 CONTROLS AND COUPLINGS

The controls and coupling for F-50HC are described in **Table 1.3** and **Figure 1.3**.

Table 1.3 CONTROLS AND COUPLINGS FOR F-50HC COMPRESSOR UNIT

No.	ITEM	FUNCTIONS
1	HE-GAS SUPPLY CONNECTOR	To use for connecting a Flex Line (for Supply He-gas line)
2	HE-GAS RETURN CONNECTOR	To use for connecting a Flex Line (for Return He-gas line)
3	SUPPLY PRESSURE GAUGE	To indicate a filled He-gas pressure in the compressor unit, during not in operation of the compressor unit, and a compressed He-gas pressure (Supply Pressure) can be indicated under the operating condition.
4	RETURN PRESSURE GAUGE	To indicate a filled He-gas pressure in the compressor unit, during not in operation of the compressor unit, and a compressed He-gas pressure (Return Pressure) can be indicated under the operating condition.
5	HE-GAS CHARGE CONNECTOR	To use for charging and refilling a He-gas.
6	COOLING WATER INLET CONNECTOR	A connector for cooling water inlet. (PT3/8 inch, Female type)
7	COOLING WATER OUTLET CONNECTOR	A connector for cooling water outlet. (PT3/8 inch, Female type)
8	MAIN POWER SWITCH : (QF1)	A twist handle for main electric power supply and for protection from over-current and short-circuit.
9	HIGH PRESSURE GAS BY PASS INDICATING LAMP (LED4)	To indicate an Open/Shut condition of the Solenoid Valve (SV1) ; Solenoid Valve (SV1): "Close" ----- the Lamp "ON" "Open" ----- the Lamp "OFF"
10	ERROR INDICATING LAMP (LED1, LED2 and LED3)	To indicate temperature error and to shut down the Compressor Unit , in case of higher temperature than the setting temperature (TS1, TS2 and TS3).
11	HOUR METER : (HM)	To indicate a total operating hour of the compressor unit, and the hour counting will be referred for maintenance interval.
12	DRIVE SWITCH : (SA1)	A seesaw switch for start-up and shut-down operation for the compressor unit. The refrigerating system can be in a operating condition by the DRIVE SWITCH "ON" after switching the MAIN POWER SWITCH "ON" condition.
13	REMOTE DRIVE SWITCH : (SA3)	The compressor unit can be operated remotely with the external control by switching "REMOTE", and cannot be started up in condition of switching "REMOTE" after the Drive Switch operated.
14	COLD HEAD DRIVE SWITCH : (SA2)	A switch for operating the COLD HEAD maintenance only. Under the MAIN POWER SWITCH "ON" and the DRIVE SWITCH "OFF". Caution; <i>Be sure to turn it OFF in normal operation.</i> <i>Using the compressor unit with the cold head drive switch turned ON may result in misoperation or malfunction.</i>

**Table 1.3 CONTROLS AND COUPLINGS FOR F-50HC COMPRESSOR UNIT
(Continued)**

15	DIAGNOSTIC INTERFACE : (JR)	To use for the external signal output of condition monitoring for the compressor unit. The connector to be "D-Sub 15 Pins (Female type)" in use. Locking Nut is #4-40UNC. Warning; Pay special attention to its wiring when using the external connector on the Compressor Unit. <u>Connecting a jumper wire between Pins No.6 - No.8, No.6 - No.13 and No.6 - No.15 may result in misoperation in some of safety devices in the equipment, causing electric shock, burn or malfunction.</u>
16	GROUND TERMINAL : (PE)	A connector for the earth wiring, and verify the tight connecting for earth wiring as well as Input Power Cable.
17	FIELD TERMINAL : (TB0)	To use for connecting of input power supply cable. At a connecting power cable, verify the phase label markings L1, L2 and L3. The compressor unit cannot be operated in case of miss-connecting the power cable.
18	CIRCUIT PROTECTOR (CP1 , CP2)	A circuit protector for protection from over-current and short circuit.
19	COLD HEAD CONNECTOR : (JC)	To use for connecting the Cold Head Cable to supply a Cold Head driving power.
20	TERMINAL BLOCK (TB1)	To be used for input voltage adjustment.
21	GAS BY PASS CONTROL INTERFACE (BP)	The Cold Head can be stopped and re-started frequently with the Compressor Unit operated by charging the control voltage supplied from the customer side. D-Sub 9pin Female Control Voltage : 3 ~ 24 VDC, Max. 20 mA Pin No.1:+ , no.6: -
22	GAS BY PASS INDICATING LAMP (LED5)	To indicate an Open/Shut condition of the Solenoid Valve (SV2); Solenoid Valve (SV2): "Close" ----- the Lamp "OFF" "Open" ----- the Lamp "ON"

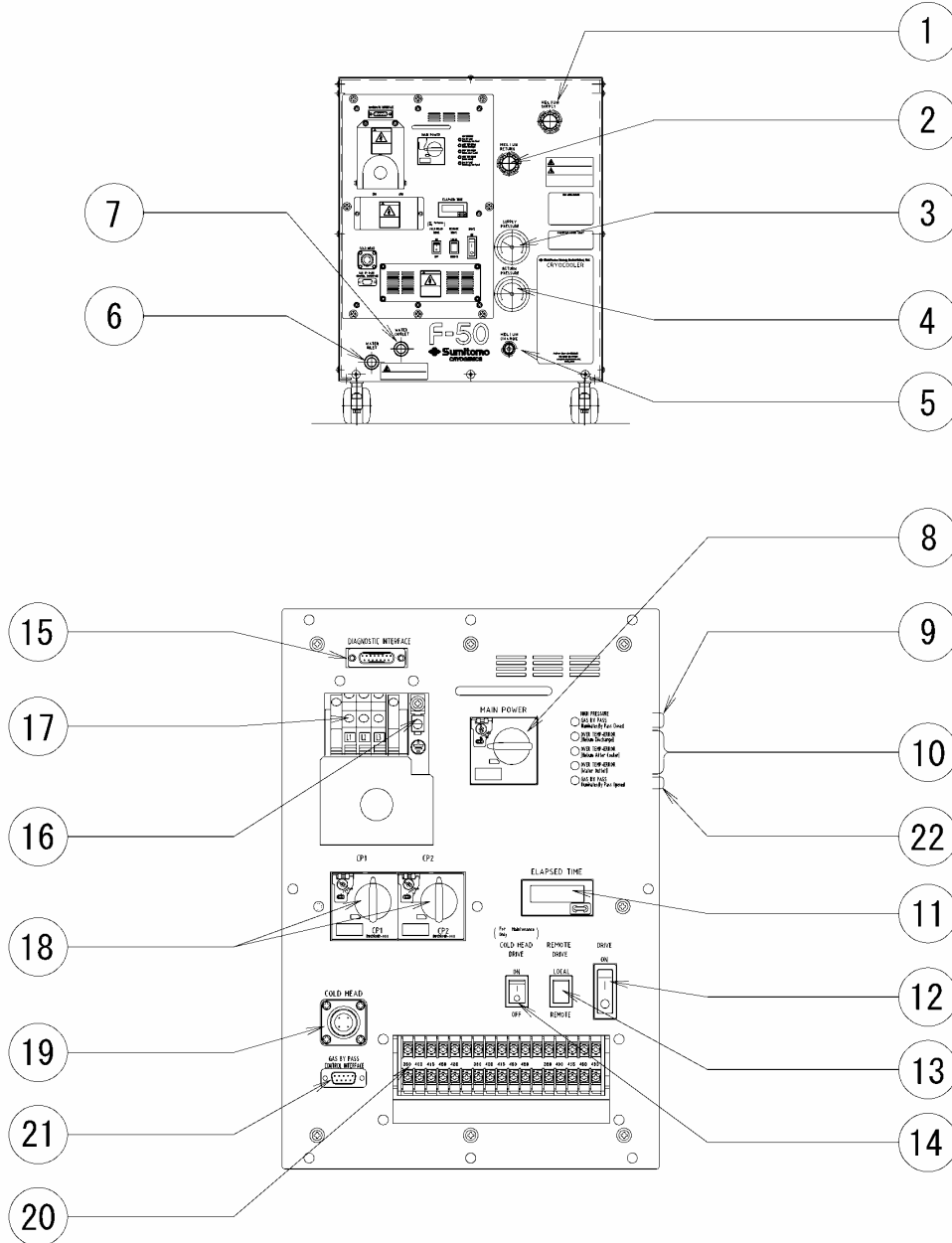

XR605B0247CQ

Figure 1.3 CONTROLS AND COUPLINGS FOR F-50HC COMPRESSOR UNIT

1-2-2 GAS AND OIL FLOW IN THE COMPRESSOR UNIT

The flow diagram for F-50HC Compressor Unit is shown in **Figure 1.4**.

Internal components diagram and its functions are described in **Figure 1.5** and **Table 1.4**.

The Compressor Unit works as follows;

- 1) Low pressure He gas discharged from a Cold Head can be led through a **HE-GAS RETURN CONNECTOR** to the Compressor Unit.
- 2) The low pressure (Return) He gas can pass through a **STORAGE TANK** and a **FILTER**, and flow into a **COMPRESSOR CAPSULE**.
- 3) The low pressure He gas will be compressed and pressurized in the **COMPRESSOR CAPSULE**, and the high pressure with high temperature He gas after the compression will be discharged from the **COMPRESSOR CAPSULE** outlet.
- 4) The high pressure with high temperature He gas will be led to a water cooled **HE-GAS COOLER** and cooled down in the cooler.
- 5) The high pressure He gas after cooling will flow into an **OIL SEPARATOR** to separate an almost all of lubricating oil mist from the high pressure He gas.
- 6) The separated lubricating oil can be returned to the **COMPRESSOR CAPSULE** through a lub oil return pipings.
- 7) The high pressure He gas discharged from the **OIL SEPARATOR** will be led to an **ADSORBER**.
- 8) The remained lub oil contents in the high pressure He gas can be adsorbed through an active charcoal layer to make the high pressure He gas being pure.
- 9) The pure high pressure He gas can be supplied to the Cold Head through a **HE-GAS SUPPLY CONNECTOR**.

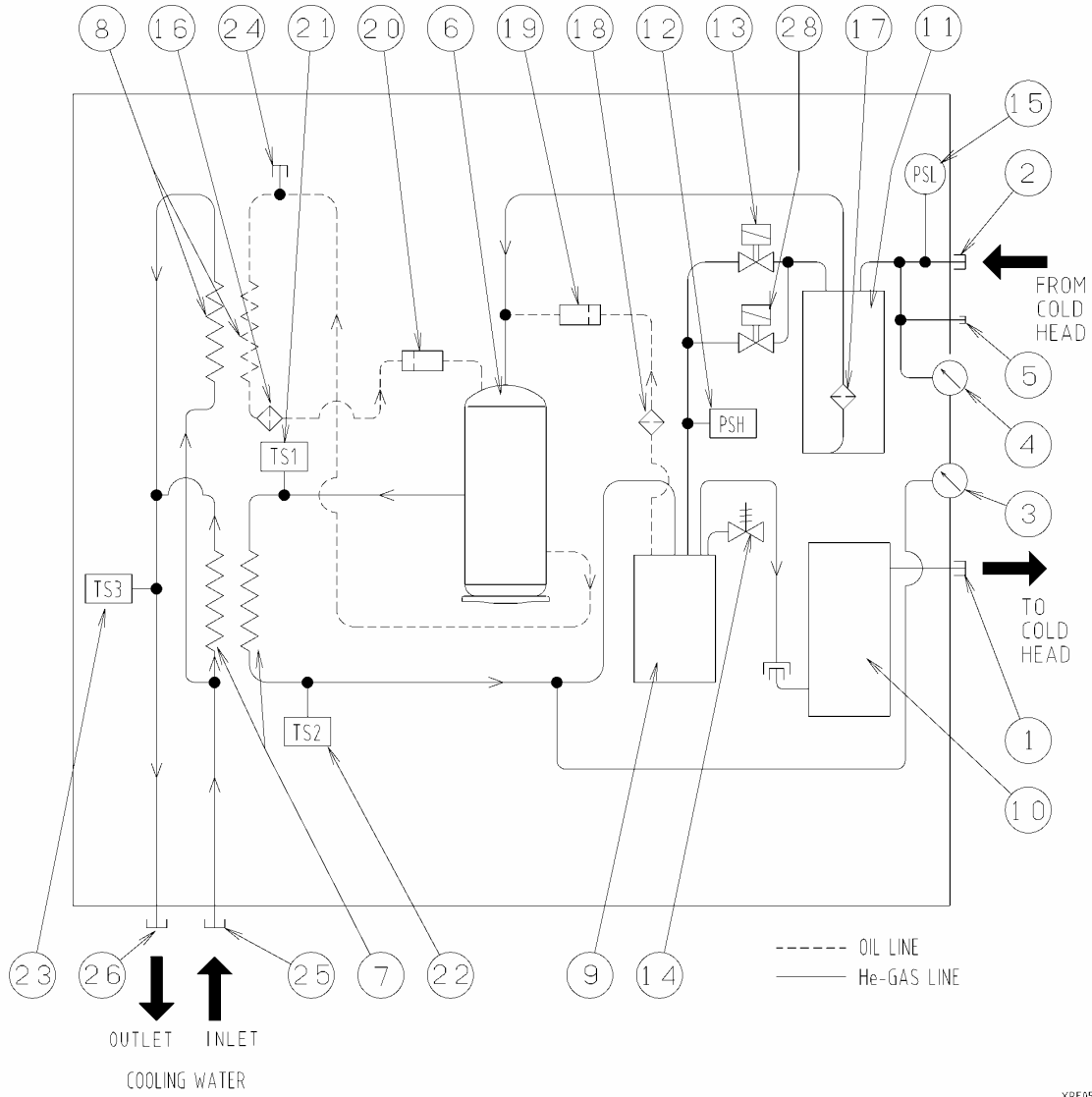

Figure 1.4 HELIUM GAS FLOW DIAGRAM FOR F-50HC COMPRESSOR UNIT

XRE05B0244A0

1-2-3 INTERNAL COMPONENTS

The parts list and its functions are described in **Table 1.4**.

The He-gas flow diagram and internal components are shown in **Figure 1.4** and **Figure 1.5**.

Table 1.4. FUNCTIONS OF THE INTERNAL COMPONENTS FOR F-50HC COMPRESSOR UNIT

No.	PARTS	FUNCTIONS
1	HE-GAS SUPPLY CONNECTOR	To use for connecting a Flex Line (for Supply He-gas line).
2	HE-GAS RETURN CONNECTOR	To use for connecting a Flex Line (for Return He-gas line).
3	PRESSURE GAUGE (SUPPLY SIDE)	To indicate a filled He-gas pressure and compressed He-gas pressure of the unit.
4	PRESSURE GAUGE (RETURN SIDE)	To indicate a filled He-gas pressure and expanded He-gas pressure of the unit.
5	HE-GAS CHARGE CONNECTOR	To use for charging and refilling a He-gas.
6	COMPRESSOR CAPSULE	A He-gas compressed for the unit.
7	HE-GAS COOLER	A water cooled type heat exchanger for compressed He-gas.
8	OIL COOLER	A water cooled type heat exchanger for recirculating lub oil.
9	OIL SEPARATOR	To eliminate oil contamination from the compressed He-gas.
10	ADSORBER	To use for eliminating a remained oil mist in the compressed He-gas after treatment by the Oil Separator.
11	STORAGE TANK	A He-gas reservoir for piping to Compressor Capsule.
12	HIGH SIDE PRESSURE SWITCH : PSH	A pressure sensor for compressed He-gas pressure control.
13	SOLENOID VALVE(SV1)	An electro-magnetic operation valve for pressure buildup control.
14	RELIEF VALVE	To keep a maximum high pressure for the He-gas piping safely.
15	LOW SIDE PRESSURE SWITCH : PSL	A pressure sensor for compressed He-gas pressure control.
16	FILTER	To eliminate contaminators and debris from a recirculating lub oil.
17	FILTER	To eliminate contaminators and debris from a He-gas suction for a Compressor Capsule.
18	FILTER	To eliminate contaminators and debris from a lub oil return of Oil Separator.
19	ORIFICE	To use for adjusting a recirculating lub oil return of Oil Separator.
20	ORIFICE	To use for adjusting a recirculating lub oil flow.
21	THERMOSTAT : TS1 90 deg.C	A thermal sensor & controller for the compressed He-gas temperature of compressor outlet.
22	THERMOSTAT : TS2 60 deg.C	A thermal sensor & controller for the compressed He-gas temperature of He-gas cooler outlet.
23	THERMOSTAT : TS3 60 deg.C	A thermal sensor & controller for the water temperature of cooling water outlet.
24	OIL CHARGE CONNECTOR	To use for refilling a lubricating oil.
25	COOLING WATER INLET CONNECTOR	To use for connecting a cooling water piping (for Water Supply)
26	COOLING WATER OUTLET CONNECTOR	To use for connecting a cooling water piping (for Water Discharge)
27	CONTROL BOX	An electronic control, surveillance and alarming system for the He-gas Compressor Unit.
28	SOLENOID VALVE(SV2)	An electro-magnetic operation valve for individual operation of Compressor.

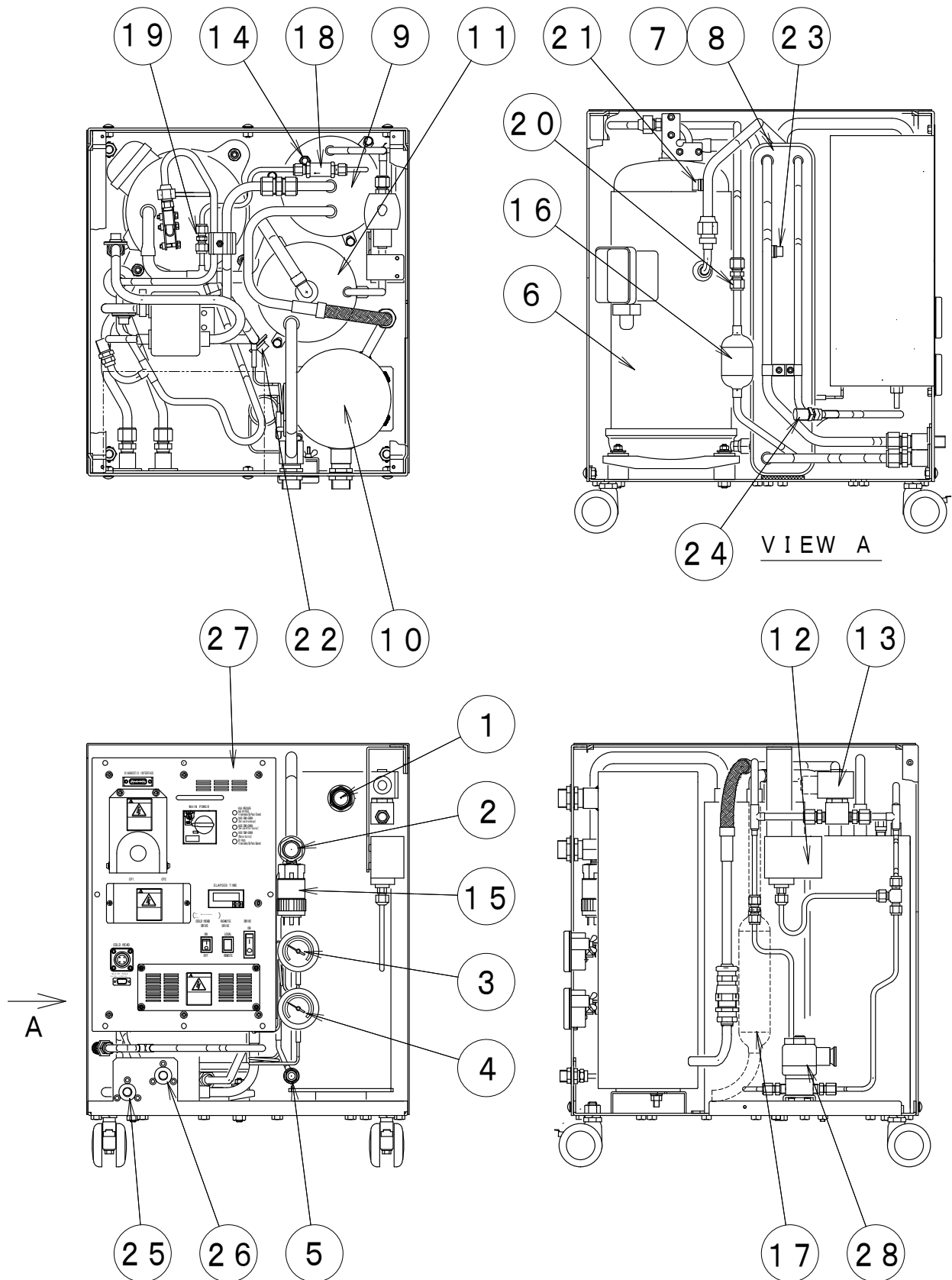

XRE05B0241BQ

Figure 1.5 COMPONENTS OF F-50HC COMPRESSOR UNIT

1-3 ELECTRICAL DESCRIPTION

1-3-1 DIAGNOSTIC INTERFACE

WARNING

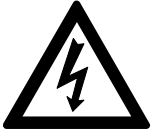

<Warning about electric shock>
 This cryocooler includes a high-voltage section. Touching it may result in electric shock. Handle it with extreme care.

Pay special attention to its wiring when using the external connector on the compressor unit. Connecting a jumper wire between Pins No.6 - No.8, No.6 - No.13 and No.6 - No.15 may result in misoperation in some of safety devices in the equipment, causing electric shock, burn or malfunction.

“IMPORTANT”

See the “ELECTRICAL SCHEMATIC” of F-50HC Compressor Unit, for detail.

“IMPORTANT”

The maximum allowable tightening torque of the D-Sub Connector lock screw (#4-40UNC) is 0.17 Nm.

Diagnostic Interface can be used monitoring the status of the Compressor Unit and the remote control sequences of the Compressor Unit are described in **Table 1.5**.

The “D-sub” pins indicated in **Figure 1.6** on the control panel for the Compressor Unit can be applied to an initial condition monitoring for a first-aid diagnostics of the Compressor Unit by means of measuring the each item with a digital Volt/Ohm Meter. The Fault Condition classified the digital meter reading as referred to the **Table 1.5** can be identified simply an actual operation condition of the Compressor Unit in the field.

Table 1.5 REMOTE CONTROL / ALARM

No.	ITEM	OPERATION		PIN No.	FAULT CONDITION*
1	Pressure Alarm Signal	Contact	Normal	1, 2	> 10 ⁶ ohm
	Alarm		Close Open		
2	Temp. Alarm Signal	Contact	Normal	3, 4	> 10 ⁶ ohm
	Alarm		Close Open		
3	Drive Indication	DC Power	Operate	6, 7	0 V
	Stop		24V DC(0.15A max.) 0V		
4	Control Voltage	DC Power	Output 24V DC(0.15A max.), when Main Power SW is “ON”		7, 13
5	Remote Reset	Relay	Pulsed 24VDC for 1 second to be furnished by user.		12, 14
6	Remote Drive	Contact	Drive	Close	8, 15
			Stop	Open	

* Digital Volt./Ohm Meter Reading

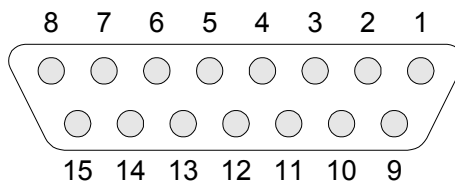

Figure 1.6 DIAGNOSTIC INTERFACE WIRING ON THE COMPRESSOR UNIT

1-3-2 SAFETY DEVICES

The safety devices list for Compressor Unit is shown in **Table 1.6**.

Table 1.6 SAFETY DEVICES OF F-50HC

ITEM	FUNCTIONS
THERMOSTAT : (TS1)	Setting temperature; 90 deg.C ---- approx. To shut down the Compressor Unit and illuminate the OVER TEMP-ERROR lamp and signal a high temperature alarm to the DIAGNOSTIC INTERFACE, in case of higher temperature of a compressed He-gas at a compressor outlet than the setting temperature.
THERMOSTAT : (TS2)	Setting temperature; 60 deg.C ---- approx. To shut down the Compressor Unit and illuminate the OVER TEMP-ERROR lamp and signal a high temperature alarm to the DIAGNOSTIC INTERFACE, in case of higher temperature of a compressed He-gas at a He-gas cooler outlet than the setting temperature.
THERMOSTAT : (TS3)	Setting temperature; 60 deg.C ---- approx. To shut down the Compressor Unit and illuminate the OVER TEMP-ERROR lamp and signal a higher temperature alarm to the DIAGNOSTIC INTERFACE, in case of higher temperature of a water at a cooling water outlet than the setting temperature.
SOLENOID VALVE : (SV1)	To stabilize a pressure for even of the He-gas between the Supply and Return piping, at a shut off the Compressor Unit.
HIGH PRESSURE SWITCH : (PSH)	Setting pressure; "Operate" 2.55 MPa ---- approx. "Reset" 2.26 MPa ---- approx. To adjust a Supply He-gas pressure smoothly by a function of the pressure switch for Open and/or Shut, in case of higher pressure of the Supply He-gas than the setting pressure.
LOW PRESSURE SWITCH : (PSL)	Setting Pressure; "Operate" 0.15 MPa ---- approx. To shut down the Compressor Unit and signal a Low pressure alarm to the External Connector, in case of lower pressure of a compressed He-gas caused by a smaller quantity of He-gas than original filling in the compressor unit.
RELIEF VALVE	Setting pressure; "Operate" 2.61 - 2.75 MPa "Reset" 2.50 MPa ---- minimum To adjust a Supply He-gas pressure smoothly by a function of the Relief Valve for blowing off the He-gas to the atmosphere, in case of higher pressure of Supply He-gas than the setting pressure.
MAIN POWER SWITCH : (QF1)	Setting current; 16 A To shut down the Compressor Unit, in case of occurring over-current and/or short-circuit than the setting current.
PHASE FAILURE PROTECTION CIRCUIT :	To avoid starting-up of the Compressor Unit in case of an abnormal operation caused by irregular connecting of Input Power Cable such as failure connecting.
CIRCUIT PROTECTOR (CP1, CP2)	Setting current; 0.63 A (Both CP1 and CP2) To protect the Compressor Unit from the over-load caused by short-circuit and/or any other electrical failure in the DC power or the Solenoid Valve.

2 INSTALLATION

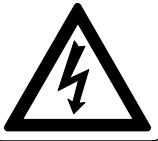
WARNING**<Warning about electric shock>**

This cryocooler includes a high-voltage section. Touching it may result in electric shock. Handle it with extreme care.

Make sure no power is applied to the compressor unit before starting the installation. Failing to observe this precaution may result in electric shock.

Do not install the equipment near places subject to condensation such as a watering place. Failing to observe this precaution may result in electric shock or malfunction.

Do not install the equipment in a dusty environment. Failing to observe this precaution may result in electric shock or malfunction.

Make sure the power specification of the cryocooler used conforms to the customer's power supply before using the equipment. Using the cryocooler with a non-conforming power supply may result in electric shock or malfunction.

If the compressor unit used is the F-50H, F-50HC (water cooled, high voltage type), pay attention to the setting of the applicable input supply voltage. The product is shipped with the input supply voltage set to 400V. Before installing the equipment, be sure to check your supply voltage and change it to the appropriate setting if necessary. Operating the equipment with your supply voltage different from the setting of the compressor unit may result in electric shock or malfunction.

Make sure no power is applied to the compressor unit before starting operation when connecting or disconnecting the cold head power cable. Failing to observe this precaution may result in electric shock.

Be sure to turn off and Lock Out and Tag Out with OFF position the main power of the customer's power source before connecting or disconnecting the input power cable to the Compressor Unit, and then remove the input power cable from the main power. Failing to observe this precaution may result in electric shock.

Do not change the setting of the dial above the main power switch of the compressor unit under any circumstances. Failing to observe this precaution may result in electric shock.

WARNING**<Warning about explosion, escape of gas>**

This cryocooler (cold head, compressor unit, compressor adsorber, flex lines) contains a high-pressure (about 1.62 MPa) helium gas sealed in. Hitting the equipment with a sharp edge or touching it with a pointed object may cause explosion or escape of gas. Handle the equipment with extreme care.

The minimum bending radius of the flex lines is 150mm (intermediate), 300 mm (terminal). Bending the flex lines at a smaller angle may cause explosion or escape of gas, and so this should be avoided.

Do not disassemble the equipment for purposes other than maintenance specified in this service manual under any circumstances. Disassembling the equipment may result in electric shock, explosion or escape of gas.

Install the cryocooler in the ventilated area, otherwise it may result in asphyxiation in case the helium gas is purged or leaked.

WARNING

Do not put the heat sensitive or flammable object near the Compressor Unit, or result in fire, injury or malfunction of the system.

CAUTION**<Caution against misoperation>**

Do not tilt it by more than 30 degrees when carrying the compressor unit. Tilting it by more than 30 degrees may cause oil sealed in the unit to move, preventing the cryocooler from operating normally.

This cryocooler is intended for the exclusive use indoors. It cannot be used outdoors. Failing to observe this precaution may prevent the cryocooler from operating normally.

Do not use inverter for the main power source of the compressor unit. Operating with inverter may result in the damage or malfunction of the compressor electric circuit.

Avoid using the transformer for the main power source of the compressor unit. If the transformer is installed at the upstream of the unit, lacking phase protection circuit with the cryocooler occurs in a malfunction. That may result in misoperation or malfunction. When using the transformer, install the other lacking phase protection device in upstream of the transformer.

Do not get on the compressor unit or put an object on top of it. Failing to observe this precaution may prevent the cryocooler from operating normally or cause injury.

Secure enough space around the compressor unit for heat radiation and maintenance. Failing to secure enough space may result in misoperation or malfunction. (See the technical instruction of the compressor unit used, for details.)

If the compressor unit used is a water-cooled type (F-50L, F-50H, F-50HC), use cooling water with appropriate temperature, flow rate and water quality. Using inappropriate cooling water may result in misoperation or malfunction. (See the technical instruction of the compressor unit used, for details.)

If the compressor unit used is a water-cooled type (F-50L, F-50H, F-50HC), do not use the demineralized water for cooling water. Using demineralized water for cooling water may result in water leakage or malfunction. (See the technical instruction of the compressor unit used, for details.)

Be sure to check the flat rubber gasket of the self seal coupling of the cold head and compressor unit for dirt, dust or to see whether the flat rubber gasket is attached correctly, before connecting the flex lines. Connecting the flex lines with an abnormal flat rubber gasket setting may cause escape of gas.

This cryocooler (cold head, compressor unit, compressor adsorber, flex lines) is shipped with a helium gas at about 1.62 MPa sealed in. Be sure to adjust the pressure to an appropriate value according to the cold head used before operating the equipment. Using the cryocooler at an improper pressure may cause misoperation.

Pay attention to the contamination when charging a helium gas. The contamination may result in occurrence of the noise from the Cold Head or decreasing the cooling capacity.

2-1 SITE REQUIREMENT

CAUTION**<Caution against misoperation>**

Do not use inverter for the main power source of the compressor unit. Operating with inverter may result in the damage or malfunction of the compressor electric circuit.

Avoid using the transformer for the main power source of the compressor unit. If the transformer is installed at the upstream of the unit, lacking phase protection circuit with the cryocooler occurs in a malfunction. That may result in misoperation or malfunction. When using the transformer, install the other lacking phase protection device in upstream of the transformer.

Secure enough space around the compressor unit for heat radiation and maintenance. Failing to secure enough space may result in misoperation or malfunction. (See the technical instruction of the compressor unit used, for details.)

If the compressor unit used is a water-cooled type (F-50L, F-50H, F-50HC), use cooling water with appropriate temperature, flow rate and water quality. Using inappropriate cooling water may result in misoperation or malfunction. (See the technical instruction of the compressor unit used, for details.)

If the compressor unit used is a water-cooled type (F-50L, F-50H, F-50HC), do not use the demineralized water for cooling water. Using demineralized water for cooling water may result in water leakage or malfunction. (See the technical instruction of the compressor unit used, for details.)

- An almost level and even area in the field will be selected to install the Compressor Unit.
- An area to be influenced by splashing water and/or dusts will not be selected to install the Compressor Unit installation area.
- A clean environmental condition without dirt and/or free from an exhausted heat will be selected to install the Compressor Unit in the field.
- A quality of cooling water will be secured to use for an appropriate coolant for the Compressor Unit.
- Any heat sensitive object cannot be positioned on surroundings of the Compressor Unit.

AMBIENT TEMPERATURE CONDITION

The ambient temperature must be between 5 deg.C and 28 deg.C to get the specified capacity. The system can operate up to 35 deg.C with less than 5% cooling capacity down. The maximum relative air humidity is 85%RH.

HELIUM SUPPLY SYSTEM

A helium supply system is necessary if you need to decontaminate the helium gas, or charging the helium gas that has leaked out of the system. A helium supply system includes a Grade 5 (99.999% up pure) helium gas bottle, a regulator, an outlet valve, and a charging hose or equivalent delivery line.

POWER SOURCE

Ensure the correct AC power source is available for the compressor. See **Table 1.1** for the power requirements for your system.

COOLING WATER

Ensure the correct cooling water is available for the compressor. See **Figure 1.1** and **Table 1.2** for the cooling water requirements for your system.

Operating with Antifreeze ((50/50 % mixture of water and ethylene glycol or propylene glycol)), the flow rate shall be larger than the water. See **Figure 1.1** and **Table 1.2** for the cooling water requirements for your system.

SAFETY / SEISMIC REQUIREMENT

Secure to lock the locking device of compressor castor.

SERVICE AREA

The Compressor Unit should have enough space as shown in **Figure 2.1**.



XRE058028380

Open out at least two faces

Figure 2.1 WATER-COOLED COMPRESSOR UNIT F-50HC AND ITS REQUIRED SPACE

2-2 INPUT POWER VOLTAGE SETTING

WARNING



<Warning about electric shock>
 This cryocooler includes a high-voltage section. Touching it may result in electric shock. Handle it with extreme care.

Make sure the power specification of the cryocooler used conforms to the customer's power supply before using the equipment. Using the cryocooler with a non-conforming power supply may result in electric shock or malfunction.

If the compressor unit used is the F-50H, F-50HC (water cooled, high voltage type), pay attention to the setting of the applicable input supply voltage. The product is shipped with the input supply voltage set to 400V. Before installing the equipment, be sure to check your supply voltage and change it to the appropriate setting if necessary. Operating the equipment with your supply voltage different from the setting of the compressor unit may result in electric shock or malfunction.

Be sure to turn off and Lock Out and Tag Out with OFF position the main power of the customer's power source before connecting or disconnecting the input power cable to the Compressor Unit, and then remove the input power cable from the main power. Failing to observe this precaution may result in electric shock.

Do not change the setting of the dial above the main power switch of the compressor unit under any circumstances. Failing to observe this precaution may result in electric shock.

CAUTION



<Caution against misoperation>
 Do not use inverter for the main power source of the compressor unit. Operating with inverter may result in the damage or malfunction of the compressor electric circuit.

Avoid using the transformer for the main power source of the compressor unit. If the transformer is installed at the upstream of the unit, lacking phase protection circuit with the cryocooler occurs in a malfunction. That may result in misoperation or malfunction. When using the transformer, install the other lacking phase protection device in upstream of the transformer.

The Compressor Unit can be operated on various input power voltages by changing the terminal wiring in the Compressor Unit. This terminal is located inside of the Control Box.

Initial factory setting is AC400V / 50Hz.

1. Loosen the screws that hold the terminal cover and the remove the cover.



2. Uncap the plastic cover.



2-2 INPUT POWER VOLTAGE SETTING

3. Change the wires (1L1, 1L2 and 1L3) to the appropriate setting. Tightening Torque: 1.2 Nm. Reinstall the plastic cover.

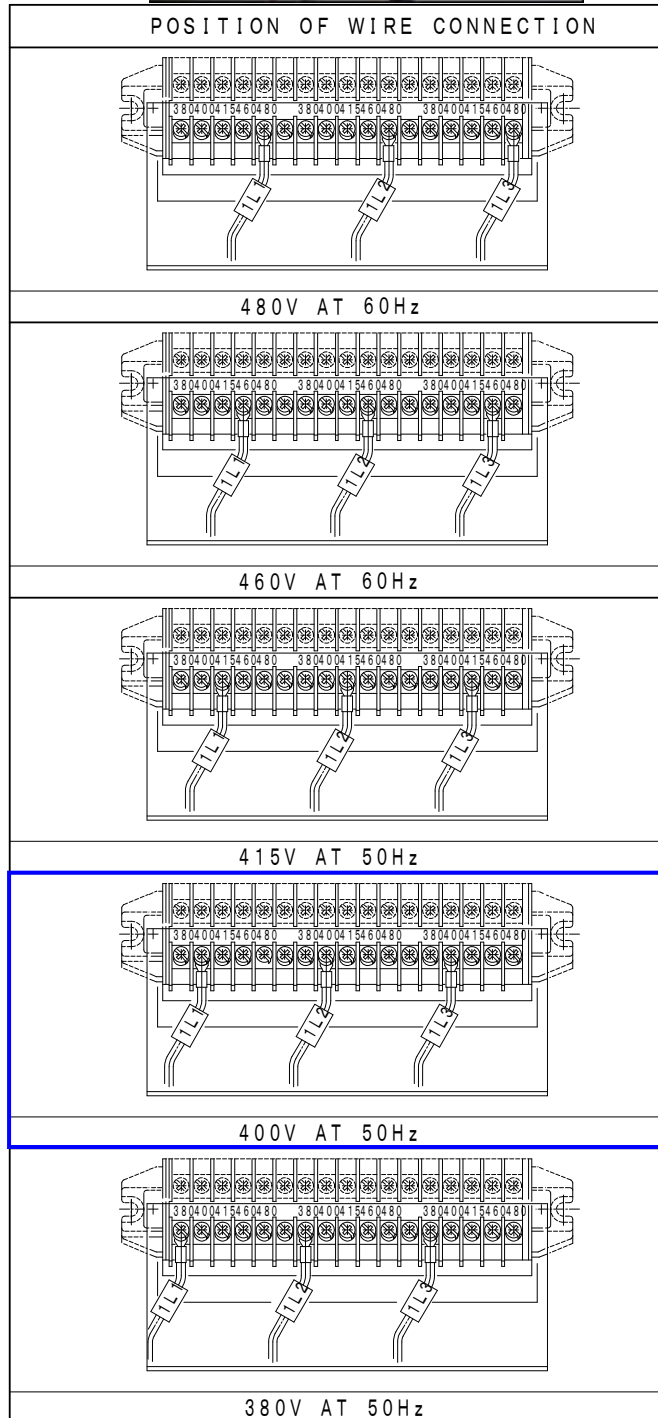
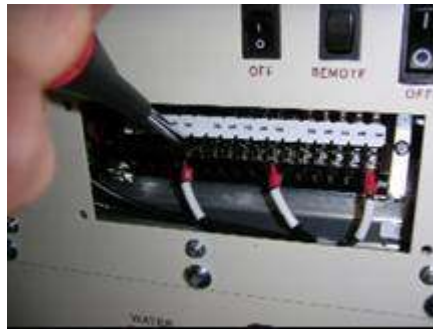

Initial factory setting
(400V @ 50Hz)

XRE05B0245AQ

Figure 2.2 TERMINAL WIRING FOR INPUT POWER VOLTAGE

2-2 INPUT POWER VOLTAGE SETTING

4. Reinstall the cover and secure them by tightening the screws.



2-3 INPUT POWER CABLE CONNECTION

WARNING

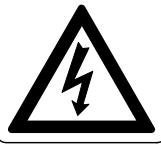

<Warning about electric shock>
 Make sure the power specification of the cryocooler used conforms to the customer's power supply before using the equipment. Using the cryocooler with a non-conforming power supply may result in electric shock or malfunction.

If the compressor unit used is the F-50H, F-50HC (water cooled, high voltage type), pay attention to the setting of the applicable input supply voltage. The product is shipped with the input supply voltage set to 400V. Before installing the equipment, be sure to check your supply voltage and change it to the appropriate setting if necessary. Operating the equipment with your supply voltage different from the setting of the compressor unit may result in electric shock or malfunction.

Be sure to turn off and Lock Out and Tag Out with OFF position the main power of the customer's power source before connecting or disconnecting the input power cable to the Compressor Unit, and then remove the input power cable from the main power. Failing to observe this precaution may result in electric shock.

Do not change the setting of the dial above the main power switch of the compressor unit under any circumstances. Failing to observe this precaution may result in electric shock.

CAUTION



<Caution against misoperation>
 Do not use inverter for the main power source of the compressor unit. Operating with inverter may result in the damage or malfunction of the compressor electric circuit.

Avoid using the transformer for the main power source of the compressor unit. If the transformer is installed at the upstream of the unit, lacking phase protection circuit with the cryocooler occurs in a malfunction. That may result in misoperation or malfunction. When using the transformer, install the other lacking phase protection device in upstream of the transformer.

"IMPORTANT"

This cryocooler is provided with a phase reverse protection circuit for the input power. If the input power is connected with reverse phase, the cryocooler does not start.

"IMPORTANT"

See "ELECTRICAL SCHEMATIC" of F-50HC Compressor Unit, for detail.

"IMPORTANT"

See "INPUT POWER CABLE (HIGH VOLTAGE)" of "APPENDIX" for detail.

Make electrical connection as follows;

Upstream Protection

Use the fuses or circuit breakers as upstream protection of L1, L2, L3. The recommended rating of the protection is maximum 30A.

Power Supply Conductor and Protective Earth Conductor

Use 75 deg.C wiring sized to 60 deg.C ampacity.
 Use copper conductor only. AWG 12 (3.3 mm²) to AWG 6 (13.3 mm²).

Compressor Unit Side

Power Supply Conductors
 Striping Length: 12 mm

Protective Earth Conductor
 Striping Length: 12 mm

User's Power Source Side

Power Supply Conductors
 Striping Length: 12 mm

Protective Earth Conductor
 Striping Length: 12 mm

See the **Table 1.1** for power requirements. The cables are marked with label and connect as follows:

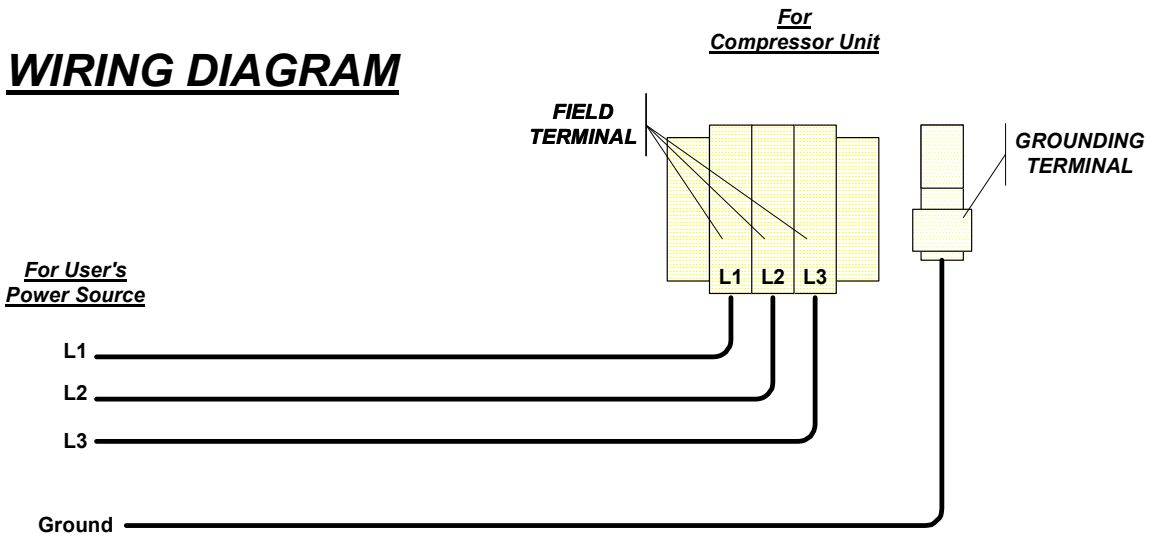

1. Loosen the screws that hold the terminal cover and the remove the cover.



2. Connect wires to terminal block, according to follow tightening torque.

Wire size	Power Supply Conductors (for FIELD TERMINAL L1, L2 and L3)		Protective Earth Conductor (for GROUNDING TERMINAL)	
	AWG 12 - 10	20.4 in-lbs	2.3 Nm	20 in-lbs
AWG 8	25 in-lbs			2.8 Nm
AWG 6	35 in-lbs			4.0 Nm



3. Reinstall the cover and secure them by tightening the screws.

3 GAS BY PASS OPERATION

3-1 GAS BY PASS OPERATION

The coldhead makes small vibration caused by displacer reciprocation in the coldhead cylinder. In case the vibration will be the problem for the customer's equipment, the coldhead can be stopped by turning off the Compressor Unit. However, the Compressor Unit does not designed for the frequent on/off operation and may cause the malfunction of the Compressor Unit.

Using the GAS BY PASS function, the coldhead can be stopped and re-started frequently with the Compressor Unit operated by charging the Control voltage (3 to 24VDC) supplied from the customer side.

Table3.1 shows the BY PASS OPERATION.

The GAS BY PASS OPERATION will stop the coldhead operation and release the high-pressure supply gas to the Return connector of Compressor Unit through the electrically operated solenoid valve by charging the Control Voltage supplied from customer side. No cooling power is generated from coldhead during GAS BY PASS OPERATION. If the control voltage will be 0V, the coldhead will re-start and continue normal operation generating specified cooling power.

Table 3.1 GAS BY PASS OPERATION

Control Voltage Input	Cold Head	Compressor Unit	By Pass	Indicator
3~24 VDC Max. 20mA	Stop	Operate	Operate (Valve Opened)	On*
0 V	Operate	Operate	Stop (Valve Closed)	Off

* The green light(No.22 in Table1.3) will turn on.

3-2 SPECIFICATIONS

The specifications of the GAS BY PASS OPERATION are summarized in **Table 3.2**.

Table 3.2 GAS BY PASS OPERATION SPECIFICATION

Control Voltage Range	DC 3 ~ 24V, Max. 20mA (Pin No.1:+, Pin No.6:-)
Frequency of Gas By Pass Operation	Maximum 6 time @ 1 hour (ON:40%, OFF60%)

3-3 INSTALLATION

"IMPORTANT"

The maximum allowable tightening torque of the D-Sub Connector lock screw is 0.17 Nm.

- 1) Connect the Control Voltage Input Cable (Customer Side) to GAS BY PASS CONTROL INTERFACE.



**GAS BY PASS CONTROL INTERFACE
(D-Sub 9pin Female)**

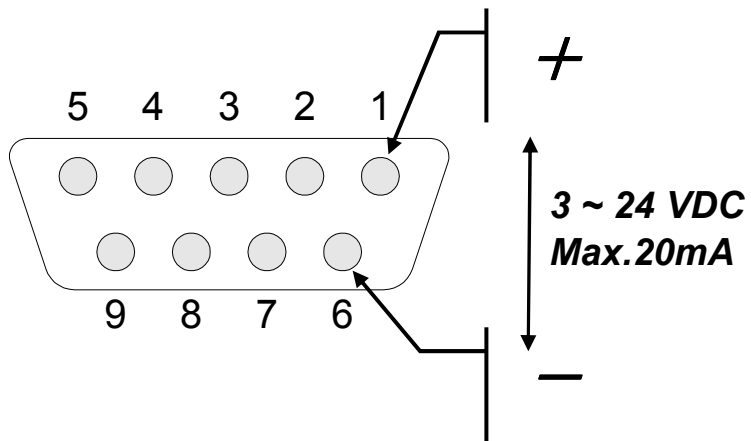

4 MAINTENANCE

WARNING



<Warning about electric shock>
 This cryocooler includes a high-voltage section. Touching it may result in electric shock. Handle it with extreme care.

Make sure no power is applied to the compressor unit before starting the installation. Failing to observe this precaution may result in electric shock.

Be sure to turn off and Lock Out and Tag Out with OFF position the main power of the customer's power source before connecting or disconnecting the input power cable to the Compressor Unit, and then remove the input power cable from the main power. Failing to observe this precaution may result in electric shock.

Do not change the setting of the dial above the main power switch of the compressor unit under any circumstances. Failing to observe this precaution may result in electric shock.

Be sure to turn off and Lock Out and Tag Out with OFF position the customer's main power before performing maintenance work such as reset of circuit protectors. Failing to observe this precaution may result in electric shock.

WARNING



<Warning about explosion, escape of gas>
 This cryocooler (cold head, compressor unit, compressor adsorber, flex lines) contains a high-pressure (about 1.62 MPa helium gas sealed in. Hitting the equipment with a sharp edge or touching it with a pointed object may cause explosion or escape of gas. Handle the equipment with extreme care.

Do not disassemble the equipment for purposes other than maintenance specified in this service manual under any circumstances. Disassembling the equipment may result in electric shock, explosion or escape of gas.

The cold head, compressor unit, compressor adsorber and flex lines are pressurized with helium gas. Purge the helium gas from all pressurized components before disposing. Open the purging valve gradually or it may result in serious injury.

When scrapping the CryoCooler, handle it as Industrial Waste and pass it over to legally qualified disposer.

Install the cryocooler in the ventilated area, otherwise it may result in asphyxiation in case the helium gas is purged or leaked.

WARNING



The Adsorber weight is about 11.5kg. When replace the adsorber, be careful of handling so that it may not get hurt.

CAUTION



<Caution against misoperation>
 Do not get on the compressor unit or put an object on top of it. Failing to observe this precaution may prevent the cryocooler from operating normally or cause injury.

Secure enough space around the compressor unit for heat radiation and maintenance. Failing to secure enough space may result in misoperation or malfunction. (See the technical instruction of the compressor unit used, for details.)

If the compressor unit used is a water-cooled type (F-50L, F-50H, F-50HC), use cooling water with appropriate temperature, flow rate and water quality. Using inappropriate cooling water may result in misoperation or malfunction. (See the technical instruction of the compressor unit used, for details.)

The cold head drive switch provided with the compressor unit is only used for maintenance. Be sure to turn it OFF in normal operation. Using the compressor unit with the cold head drive switch turned ON may result in misoperation or malfunction.

4-1 PERIODICAL MAINTENANCE

F-50HC Compressor Unit is to be required the routine maintenance. The basic maintenance work is to replace the oil mist Adsorber of the Compressor Unit for every 30,000 Hrs. operation as mentioned

Table 4.1.

Table 4.1 PERIODICAL MAINTENANCE SCHEDULE

MAINTENANCE	FREQUENCY	REMARKS
Replace Compressor Adsorber	Every 30,000 Hrs.	
Charge Helium Gas to Compressor	As required	
Cleaning Water Cooler	As required	Depending on the water conditions.
Circuit Protector Reset	As required	

4-1-1 REPLACEMENT OF THE COMPRESSOR ADSORBER

WARNING



<Warning about explosion, escape of gas>

This cryocooler (cold head, compressor unit, compressor adsorber, flex lines) contains a high-pressure (about 1.62 MPa helium gas sealed in. Hitting the equipment with a sharp edge or touching it with a pointed object may cause explosion or escape of gas. Handle the equipment with extreme care.

Do not disassemble the equipment for purposes other than maintenance specified in this service manual under any circumstances. Disassembling the equipment may result in electric shock, explosion or escape of gas.

The cold head, compressor unit, compressor adsorber and flex lines are pressurized with helium gas. Purge the helium gas from all pressurized components before disposing. Open the purging valve gradually or it may result in serious injury.

When scrapping the CryoCooler, handle it as Industrial Waste and pass it over to legally qualified disposer.

Install the cryocooler in the ventilated area, otherwise it may result in asphyxiation in case the helium gas is purged or leaked.

WARNING



The Adsorber weight is about 11.5kg. When replace the adsorber, be careful of handling so that it may not get hurt.

CAUTION



<Caution against misoperation>

Do not get on the compressor unit or put an object on top of it. Failing to observe this precaution may prevent the cryocooler from operating normally or cause injury.

The Oil Mist Adsorber is required to replace for every 30,000 Hrs operation.

Table 4.2 ADSORBER FOR COMPRESSOR UNIT

	DESCRIPTION	Q'TY	PART NUMBER	REMARKS
1	Adsorber	1	RE05ZN1287	

Table 4.3 REQUIRED TOOLS FOR ADSORBER REPLACEMENT

	TOOLS	REMARKS
1	1" open-end wrench	For Aero-quip coupling
2	1-1/8" Open-end wrench	For Aero-quip coupling
3	1-3/16" Open-end wrench	For Aero-quip coupling
4	Snoop liquid	For leak check
5	Cotton wipers	For leak check
6	13 mm Open-end wrench	For fixing nut for Adsorber
7	Screw driver (phillips(+))	For side panel of Compressor Unit.

Replace the Adsorber instructed as follows;

PREPARATION

- 1) Shut down the Cryocooler.
- 2) Disconnect the Input Power Cable from the Compressor Unit.
- 3) Disconnect the Supply and Return Flex Lines from the Compressor Unit.

REMOVING THE USED ADSORBER

- 1) Loosen the screws that hold the compressor side panel and remove the panel.



- 2) Disconnect the Adsorber Self-Sealing Coupling. Use three or two wrenches.



When you use two wrenches, use one wrench to hold the adsorber. Use the second wrench on the oil separator line coupling nut to break the connection. See figure of left side below. After breaking the connection, hold the coupling adapter with one wrench. Remove the oil separator line coupling from the adsorber with the second wrench. See figure of right side below.

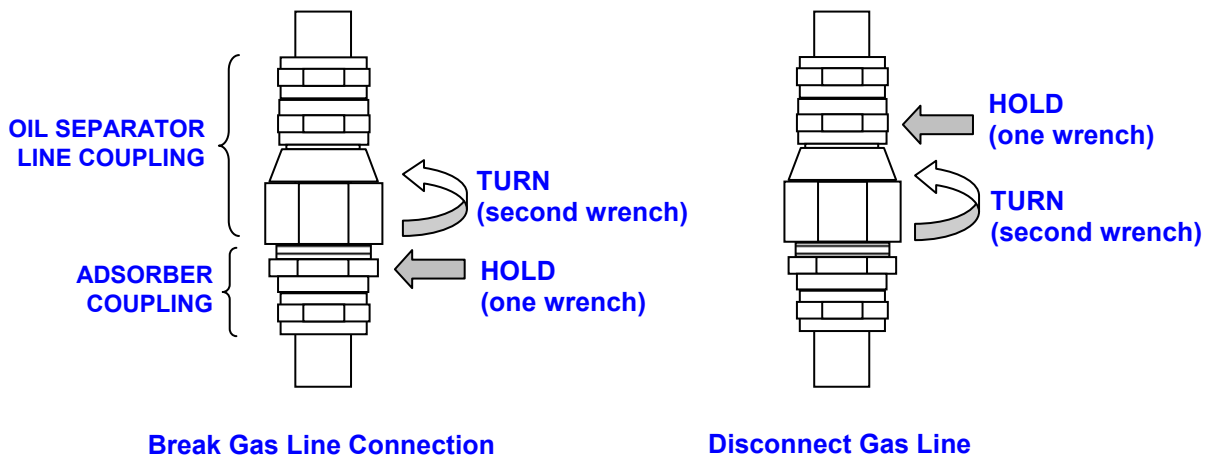

- 3) Remove the Nut secured the Adsorber to Rear Panel. Use two wrenches.



- 4) Loosen the Nut and Washer secured the Adsorber to the base panel of the Compressor Unit.



- 5) Remove the used Adsorber from the Compressor frame.



INSTALLING NEW ADSORBER

- 1) Set a new Adsorber.



Flat Washer + Spring Washer + Nut



Lock Washer



- 2) Secure the Adsorber to Front Panel by tightening Nut .



Tightening Torque: 23 Nm

- 3) Secure the Adsorber to the base panel of the Compressor Unit by tightened Nut.
Tightening Torque: 14.5 Nm

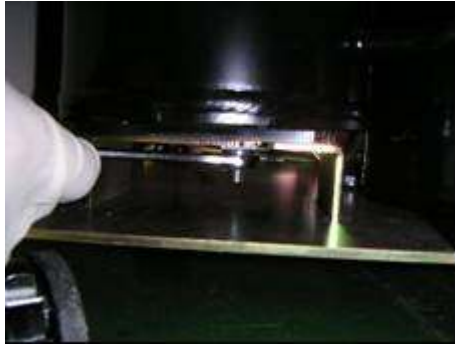

- 4) Connect the Adsorber Self-Sealing Coupling. Use three or two wrenches.
Tightening Torque: 50 Nm

When you use two wrenches, use one wrench to hold the oil separator line. Use the second wrench on the oil separator line coupling nut to connect. See figure of right below.

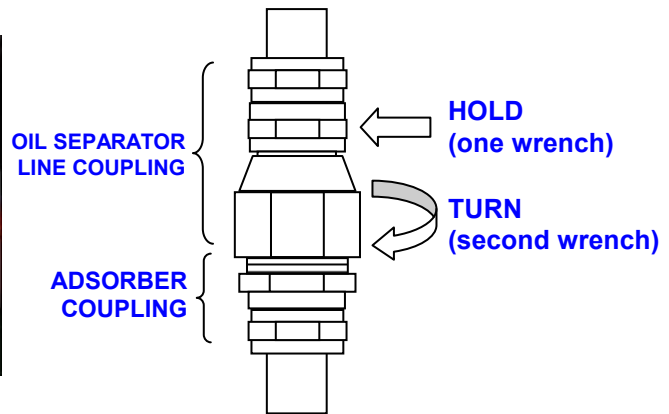

Connect Gas Line

- 5) Sprinkle "Liquid Leak Detector" on the Flex line connecting coupling, in case the bubbling is found, tighten the connecting coupling again and re-check the leakage.



Ensure that the pressure gauge indication is specified value for the type of Cold Head. Charge the helium gas, in case of low pressure indicating.

- 6) Reinstall the panels and secure them by tightening the screws.

4-1-2 RESET THE CIRCUIT PROTECTOR(S)

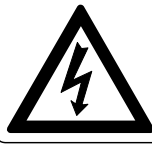
<p>WARNING</p> 	<p><Warning about electric shock> This cryocooler includes a high-voltage section. Touching it may result in electric shock. Handle it with extreme care.</p> <p>Do not change the setting of the dial above the main power switch of the compressor unit under any circumstances. Failing to observe this precaution may result in electric shock.</p> <p>Be sure to turn off and Lock Out and Tag Out with OFF position the customer's main power before performing maintenance work such as reset of circuit protectors. Failing to observe this precaution may result in electric shock.</p>
---	--

RESET PROCEDURE

- 1) Loosen the two screws that hold the circuit protectors cover and the remove the cover.



(CP1 and CP2: OFF position)

- 2) Reset the Circuit Protector(S).



- 3) Reinstall the cover and secure them by tightening the screws.



APPENDIX

ELECTRICAL SCHEMATIC

No.	PART NAME
1	ELECTRICAL SCHEMATIC of F-50HC (FOR AC CIRCUIT)
2	ELECTRICAL SCHEMATIC of F-50HC (FOR DC CIRCUIT)

DRAWINGS

No.	PART NAME
1	F-50HC Compressor Unit (Includes the special items for customer)
2	ADSORBER
3	INPUT POWER CABLE (HIGH VOLTAGE)

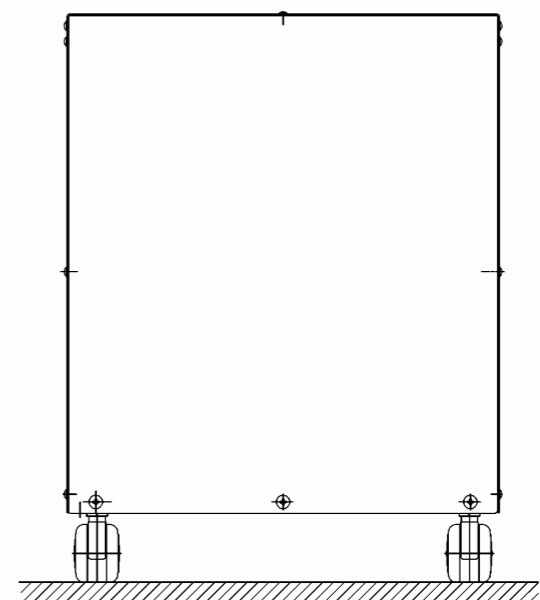
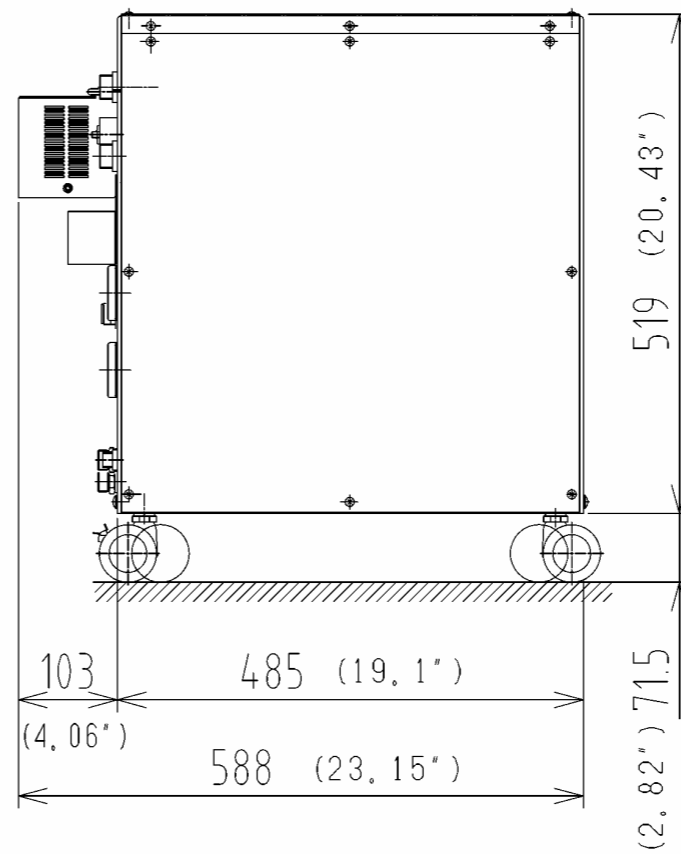
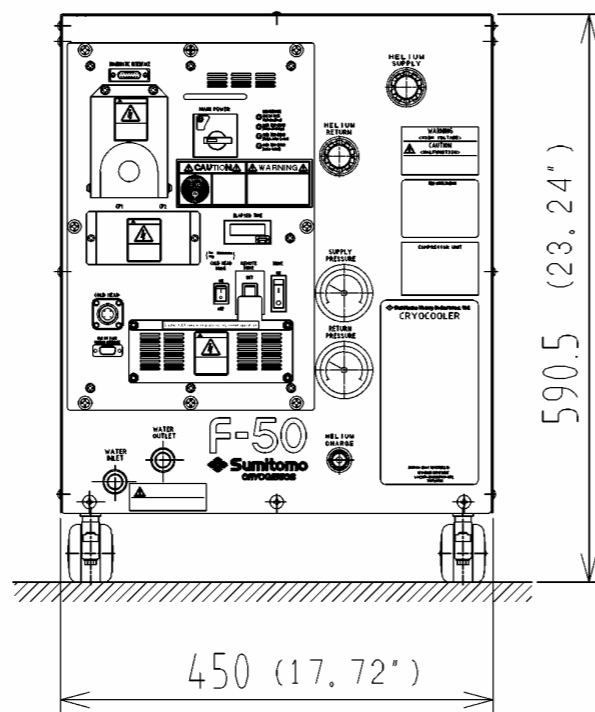
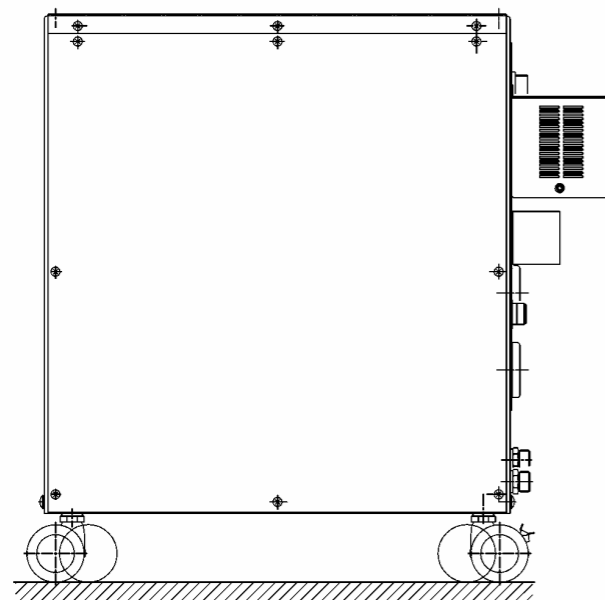
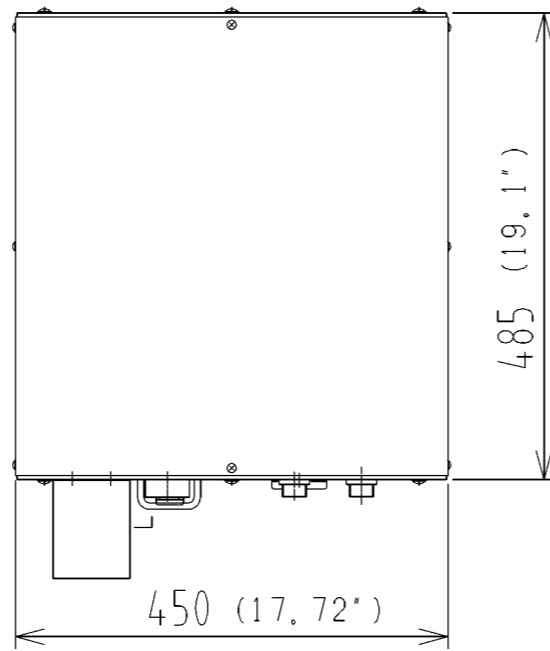

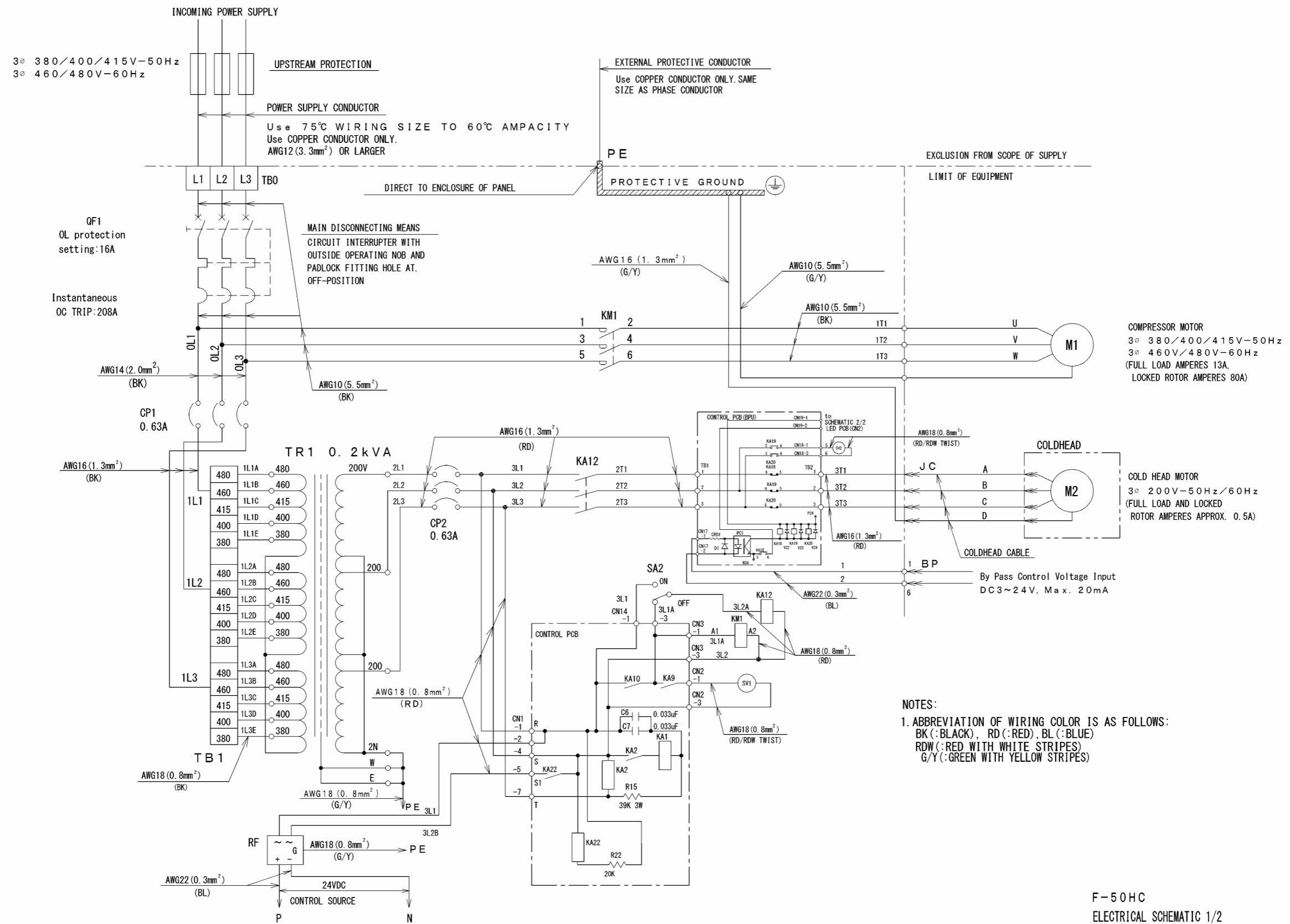

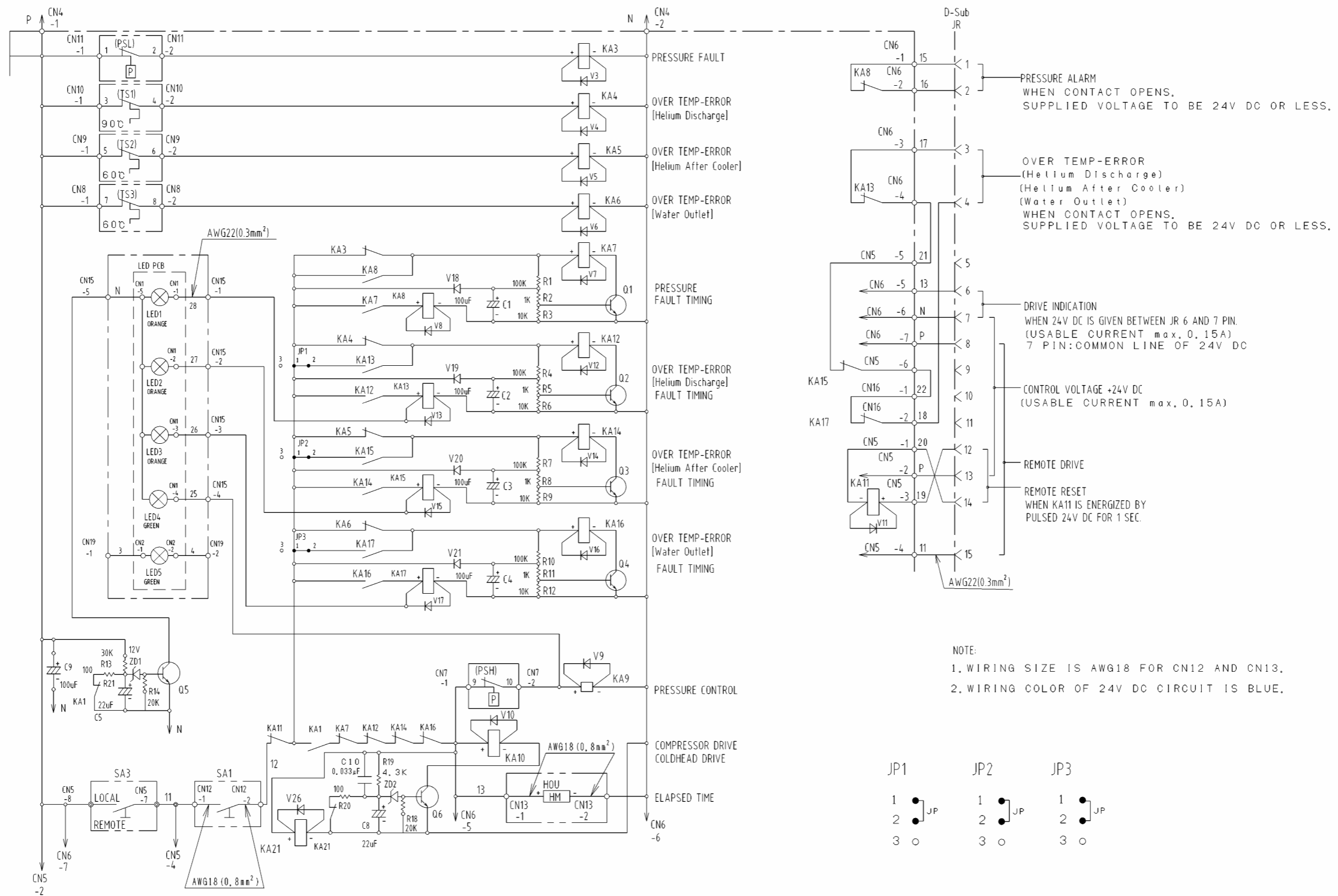

F-50HC@PMS

ELECTRICAL SCHEMATIC 2/2

XRE05Z0365A0

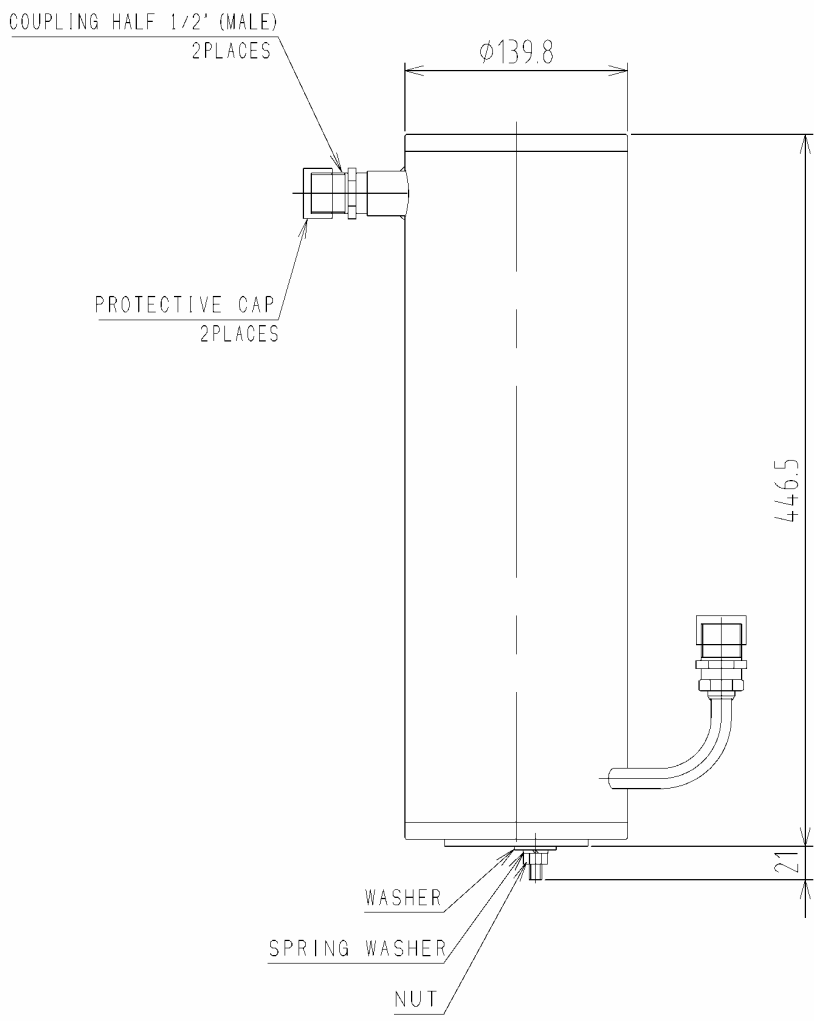
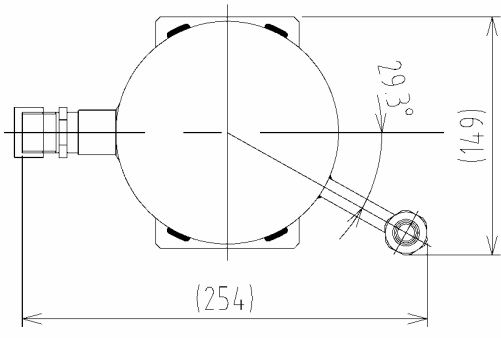

NOTE

1. CHARGED HELIUM GAS 1.62MPa.....Approx
2. MASS 11.5Kg.....Approx

XRE05B024800_E

ADSORBER

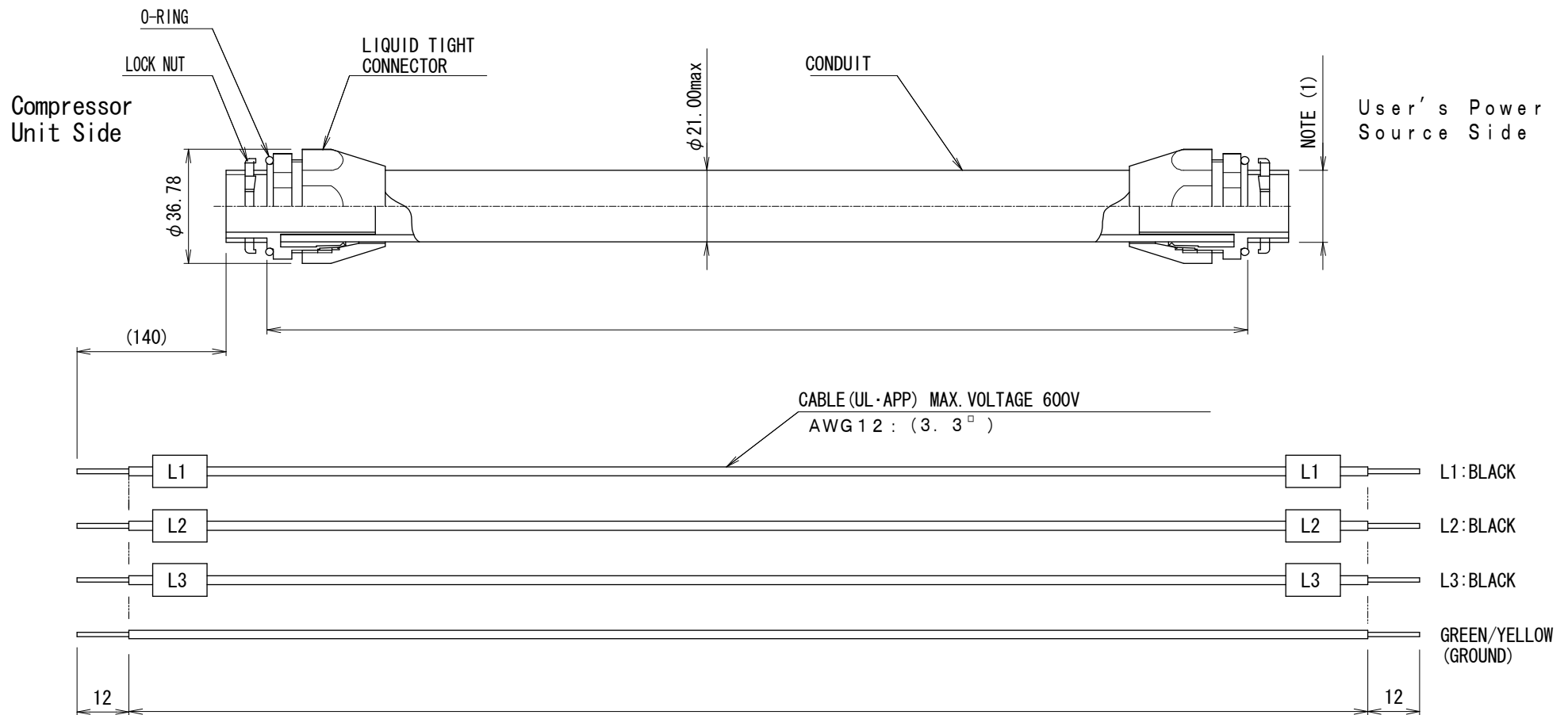

NOTE

(1) MOUNTING HOLE SIZE : MIN $\phi 22.00\text{mm}$.

(2) FOUR CABLES TO BE INSERTED IN THE CONDUIT.

INPUT POWER CABLE (HIGH VOLTAGE)
F-50H, F-50HC, F-60H, F-60HC

REVISION CONTROL

Manual No.	Revision	Remarks	Date
CD32ZZ-269	A	Publication of first edition.	DEC. 14, 2007
	B	Add the specification for the D-Sub Connector lock screw tighten torque.	APR. 04, 2008
	C	Figure 2.2 was revised.	JUL. 01, 2008
	D	The Humidity Range was added.	FEB. 05 / 2010
	E	CE Declaration was added.	JUN. 28 / 2011
	F	Change input power cable connection's tightening torque and connecting and disconnecting adsorber method.	NOV. 11 / 2011