



Sumitomo Heavy Industries, Ltd.

MANUAL NUMBER: CD32ZZ-208A

DATE: January 12 / 2006

# **TECHNICAL INSTRUCTION**

## **CSW-71D COMPRESSOR UNIT**

***For Service Personnel Only***

***Sumitomo Heavy Industries, Ltd.  
Cryogenics Division***

***2-1-1 Yato-cho, Nishitokyo-City,  
Tokyo 188-8585, Japan***

**E-mail: [cryo@shi.co.jp](mailto:cryo@shi.co.jp)  
URL: <http://www.shicryogenics.com>**

## TABLE OF CONTENTS

SECTION	ITEM	PAGE No.
	CROSS REFERANCE	1
1	GENERAL INFORMATION	2
1-1	SPECIFICATIONS	2
1-2	CONSTRUCTION	5
1-2-1	CONTROLS AND COUPLINGS	5
1-2-2	GAS AND OIL FLOW IN THE COMPRESSOR UNIT	8
1-2-3	INTERNAL COMPONENTS	10
1-3	ELECTRICAL DESCRIPTION	12
1-3-1	EXTERNAL CONNECTOR	12
1-3-2	SAFETY DEVICES	13
2	INSTALLATION	14
2-1	SITE REQUIREMENT	14
2-2	INPUT POWER CABLE CONNECTION	16
3	MAINTENANCE	18
3-1	PERIODICAL MAINTENANCE	19
3-1-1	REPLACEMENT OF THE COMPRESSOR ADSORBER	20
3-2	FUSE REPLACEMENT	24
	APPENDIX	
	ELECTRICAL SCHEMATIC	
	DRAWINGS	
	REVISION CONTROL	

**CROSS REFERENCE**

Thoroughly read this manual and following manuals before using this equipment.

<b>MANUAL NAME</b>	<b>MANUAL No.</b>
OPERATION MANUAL SRDK Series CRYOCOOLER	CD32ZZ-207
TECHNICAL INSTRUCTION RDK Series 4K COLD HEAD	CD32ZZ-209
INSTALLATION MANUAL BPU-01 BY PASS UNIT*	CD32ZZ-210

\* See the INSTALLATION MANUAL of BPU-01, if BPU-01 is used in this system.

1 GENERAL INFORMATION

1-1 SPECIFICATIONS

The specifications of CSW-71D Helium Compressor Unit are summarized in **Table 1.1**.

**Table 1.1 CSW-71D COMPRESSOR UNIT SPECIFICATION**

	for RDK-408D2, 408D, 415D	for RDK-408S2, 408S, 400B
<b>Dimension</b>		
Width	450.0 mm (17.72')	
Length	500.0 mm (19.69')*	
Height	686.5 mm (27.03')	
<b>Helium Gas Pressure</b>		
Static	1.60 - 1.65 MPa at 20 deg.C (68 deg.F) (16.3 - 16.8 kgf/cm <sup>2</sup> G) (232 - 239 psig)	1.45 - 1.50 MPa at 20 deg.C (68 deg.F) (14.8 - 15.3 kgf/cm <sup>2</sup> G) (210 - 217 psig)
Operating (High Side)** (for Reference)	2.00 - 2.20 MPa --- approx. (20.4 - 22.4 kgf/cm <sup>2</sup> G) (290 - 319 psig)	2.00 - 2.20 MPa --- approx. (20.4 - 22.4 kgf/cm <sup>2</sup> G) (290 - 319 psig)
<b>Ambient Operating Temperature</b>	5 to 28 deg.C (41 to 82.4 deg.F) 28 to 35 deg.C (82.4 to 95 deg.F) with 5% Capacity Loss	
<b>Weight</b>	120 kg (264 LBS) --- approx.	
<b>Electrical Requirement</b>		
Power Line Voltage (+/-10%)	AC 380, 400, 415 V / 50 Hz, 3 phase (3W+PE) AC 460, 480 V / 60Hz, 3 phase (3W+PE) ( ground, Commercial Power Source) <b><u>“WARNING”</u></b> <b><u>Do not use inverter for the main power source.</u></b>	
Operating Current	Max. 12 A	
Min. Circuit Ampacity	15 A	
Max. Fuse or Circuit Breaker Size	30 A	
Power Requirement	Minimum 9 kVA Recommended 12 kVA	
Power Consumption	Max. 8.3 kW / Steady State 7.5kW at 60Hz Max. 7.2 kW / Steady State 6.5kW at 50Hz <b><u>See the ELECTRICAL SCHEMATIC of “APPENDIX” for detail.</u></b>	
<b>Cooling water requirement</b>	<b><u>“CAUTION”</u></b> <b><u>Do not use the demineralized water for cooling water.</u></b>	
Min. Flow Rate	7 liter/min @ 28deg.C (1.85 gal./min @ 82.4 deg.F) <b><u>See the Figure 1.1 and Table 1.2</u></b>	
Temperature Range	4 to 28 deg.C (39.2 to 82.4 deg.F) <b><u>See the Figure 1.1 and Table 1.2</u></b>	
Quality	<b><u>See the Table 1.2</u></b>	
<b>Pressure Relief Valve Setting</b>	2.61 - 2.75 MPa (26.6 - 28.0 kgf/cm <sup>2</sup> G, 378 - 398 psig)	
<b>Gas Supply Connector</b>	1/2-inch Coupling	
<b>Gas Return Connector</b>	1/2-inch Coupling	

\* Input Power Cable Terminal Cover is 98.0 mm (3.9'). See the **Figure 1.2**.

\*\* The operating pressure varies according to the heat load of cold head and temperature around the equipment.

**COOLING WATER REQUIREMENT**

The typical flow characteristics are shown in **Figure 1.1**, and cooling water requirement are shown in **Table 1.2**.

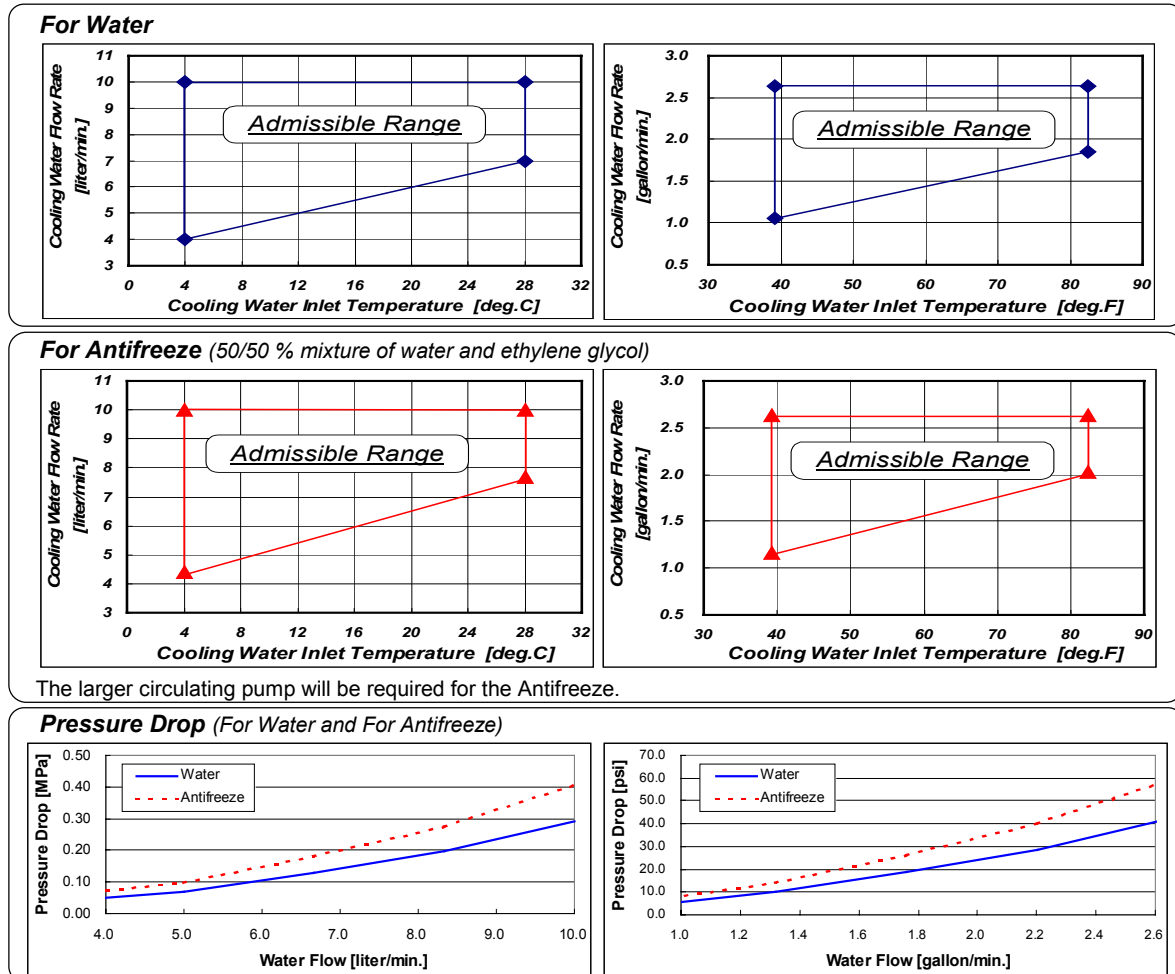

The larger circulating pump will be required for the Antifreeze.

**Figure 1.1 COOLING WATER TYPICAL FLOW CHARACTERISTICS**

**Table 1.2 COOLING WATER SPECIFICATIONS**

<b>&lt;CHARACTERISTICS&gt;</b>	Inlet Temperature Range [deg.C] (deg.F)	[4.0 ~ 28.0] (39.2 ~ 82.4)
	Inlet Pressure Range [MPa] (psig)	[0.20 ~ 0.69] (29 ~ 100)
	Flow Rate [liter/min.] (gallon/min.)	[4.0 ~ 10.0] (1.1 ~2.6)
	Pressure Drop [MPa] (psig)	[0.05 ~ 0.32] (7.0 ~ 46.0)
	Temperature Rise [deg.C] (deg.F)	<Steady State> [8.7 ~ 21.9] (15.7 ~ 39.4) for 50Hz [10.8 ~ 26.9] (19.4 ~ 48.4) for 60Hz <Maximum> [9.6 ~ 23.9] (17.3 ~ 43.1) for 50Hz [11.9 ~ 29.6] (21.4 ~ 53.3) for 60Hz
<b>&lt;QUALITY&gt;</b>	Heat Output [kW] (BTU/Hr)	<Steady State> [< 6.5] (< 22180) for 50Hz [< 7.5] (< 25590) for 60Hz <Maximum> [< 7.2] (< 24570) for 50Hz [< 8.3] (< 28320) for 60Hz
	pH Value	6.5 to 8.2 at 25 deg.C (77 deg.F)
	Electrical Conductivity	< 800 uS/cm at 25 deg.C
	Alkaline	< 100 PPM
	Total Hardness	< 200 PPM
	Chloride	< 200 PPM
	Sulfide	< 200 PPM
	Iron	< 1.0 PPM
	Sulfur	None, Not detectable
	Ammonium	< 1.0 PPM
	Silica	< 50 PPM
	Aggressive Carbon Dioxide	None, Not detectable
Suspended Matter	< 10 mg/liter	
Particle Size	< 100 um	

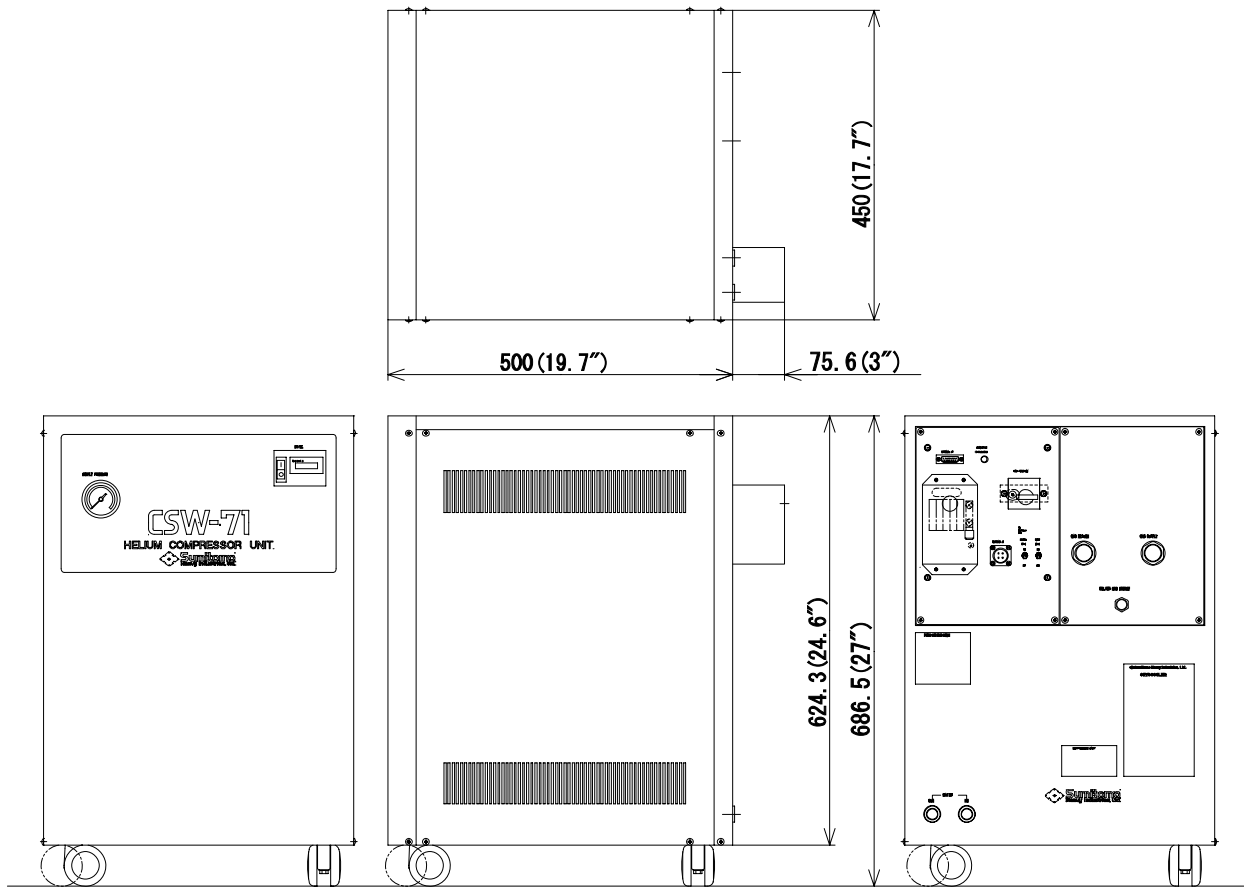

Figure 1.2 OUTLINE VIEW FOR CSW-71D COMPRESSOR UNIT

1-2 CONSTRUCTION

The function of the Compressor Unit is to supply high pressure He gas to the Cold Head and re-compress the returned He gas from the Cold Head. The Compressor Unit consists of the following major components: a Compressor Capsule, a Cooling system, Oil separation and injection system, and Adsorber.

1-2-1 CONTROLS AND COUPLINGS

The controls and coupling for CSW-71D are described in Table 1.3 and Figure 1.3.

Table 1.3 CONTROLS AND COUPLINGS FOR CSW-71D COMPRESSOR UNIT

No.	ITEM	FUNCTIONS
1	MAIN POWER SWITCH : (QF1)	A twist handle for main electric power supply and for protection from over-current and short-circuit.
2	DRIVE SWITCH : (SA1)	A seesaw switch for start-up and shut-down operation for the compressor unit. The refrigerating system can be in a operating condition by the DRIVE SWITCH "ON" after switching the MAIN POWER SWITCH "ON" condition.
3	COLD HEAD DRIVE SWITCH : (SA2)	A switch for operating the COLD HEAD maintenance only. Under the MAIN POWER SWITCH "ON" and the DRIVE SWITCH "OFF". <i>Caution; Be sure to turn it OFF in normal operation.</i> <i>Using the compressor unit with the cold head drive switch turned ON may result in misoperation or malfunction.</i>
4	REMOTE DRIVE SWITCH : (SA3)	The compressor unit can be operated remotely with the external control by switching "EXT", and cannot be started up in condition of switching "EXT" after the Drive Switch operated.
5	INDICATING LAMP : (HL)	To indicate an Open/Shut condition of the Solenoid Valve (YV) ; Solenoid Valve : "Shut" ----- the Lamp "ON" "Open" ----- the Lamp "OFF"
6	SUPPLY PRESSURE GAUGE	To indicate a filled He-gas pressure in the compressor unit, during not in operation of the compressor unit, and a compressed He-gas pressure (Supply Pressure) can be indicated under the operating condition.
7	HOUR METER : (HM)	To indicate a total operating hour of the compressor unit, and the hour counting will be referred for maintenance interval.
8	FIELD TERMINAL : (TB0)	To use for connecting of input power supply cable. At a connecting power cable, verify the phase label markings L1, L2 and L3. The compressor unit cannot be operated in case of miss-connecting the power cable.
9	GROUND TERMINAL : (PE)	A connector for the earth wiring, and verify the tight connecting for earth wiring as well as Input Power Cable.

**Table 1.3 CONTROLS AND COUPLINGS FOR CSW-71D COMPRESSOR UNIT  
(Continued)**

10	COLD HEAD CONNECTOR : (JC)	To use for connecting the Cold Head Cable to supply a Cold Head driving power.
11	EXTERNAL CONNECTOR : (JR)	To use for the external signal output of condition monitoring for the compressor unit. The connector to be "D-Sub 15 Pins (Female type)" in use. <b>Warning;</b> <i>Pay special attention to its wiring when using the external connector on the Compressor Unit.</i> <i>Connecting a jumper wire between Pins No.6 - No.8, No.6 - No.13 and No.6 - No.15 may result in misoperation in some of safety devices in the equipment, causing electric shock, burn or malfunction.</i>
12	HE-GAS SUPPLY CONNECTOR	To use for connecting a Flex Line (for Supply He-gas line)
13	HE-GAS RETURN CONNECTOR	To use for connecting a Flex Line (for Return He-gas line)
14	HE-GAS CHARGE CONNECTOR	To use for charging and refilling a He-gas.
15	COOLING WATER INPUT CONNECTOR	A connector for cooling water inlet. (PT3/8 inch, Female type)
16	COOLING WATER OUTPUT CONNECTOR	A connector for cooling water outlet. (PT3/8 inch, Female type)

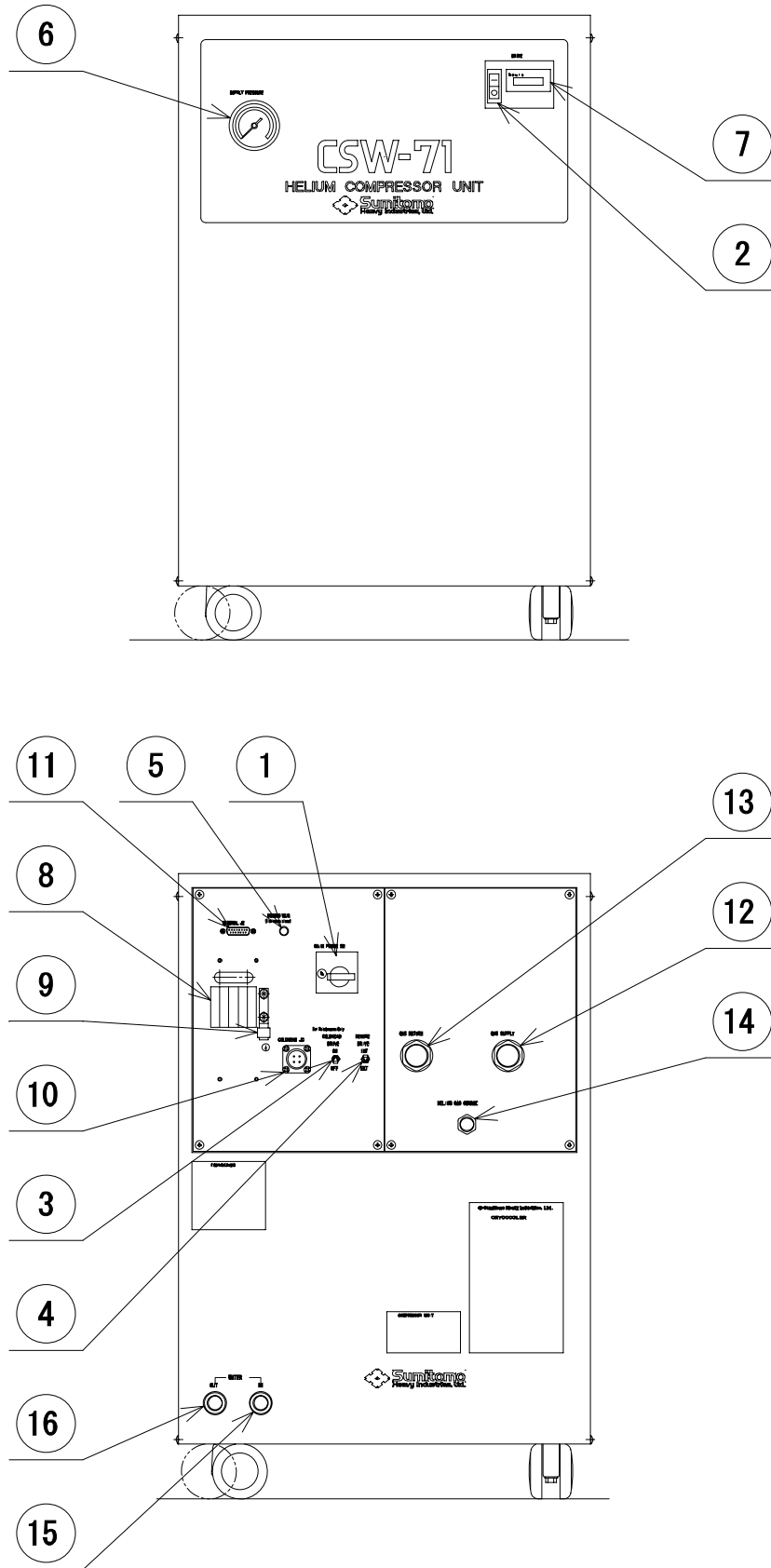

Figure 1.3 CONTROLS AND COUPLINGS FOR CSW-71D COMPRESSOR UNIT

## 1-2-2 GAS AND OIL FLOW IN THE COMPRESSOR UNIT

The flow diagram for CSW-71D Compressor Unit is shown in **Figure 1.4**.

Internal components diagram and its functions are described in **Figure 1.5** and **Table 1.4**.

The Compressor Unit works as follows;

- 1 ) Low pressure He gas (Press.: 0.59 MPa (6.0 kgf/cm<sup>2</sup>G, 85psig) & below) discharged from a Cold Head can be led through a **HE-GAS RETURN CONNECTOR** to the Compressor Unit.
- 2 ) The low pressure (Return) He gas can pass through a **STORAGE TANK** and a **FILTER**, and flow into a **COMPRESSOR CAPSULE**.
- 3 ) The low pressure He gas will be compressed and pressurized in the **COMPRESSOR CAPSULE**, and the high pressure with high temperature He gas after the compression will be discharged from the **COMPRESSOR CAPSULE** outlet.
- 4 ) The high pressure with high temperature He gas will be led to a water cooled **HE-GAS COOLER** and cooled down in the cooler.
- 5 ) The high pressure He gas after cooling will flow into an **OIL SEPARATOR** to separate an almost all of lubricating oil mist from the high pressure He gas.
- 6 ) The separated lubricating oil can be returned to the **COMPRESSOR CAPSULE** through a lub oil return pipings.
- 7 ) The high pressure He gas discharged from the **OIL SEPARATOR** will be led to an **ADSORBER**.
- 8 ) The remained lub oil contents in the high pressure He gas can be adsorbed through an active charcoal layer to make the high pressure He gas being pure.
- 9 ) The pure high pressure He gas can be supplied to the Cold Head through a **HE-GAS SUPPLY CONNECTOR**.

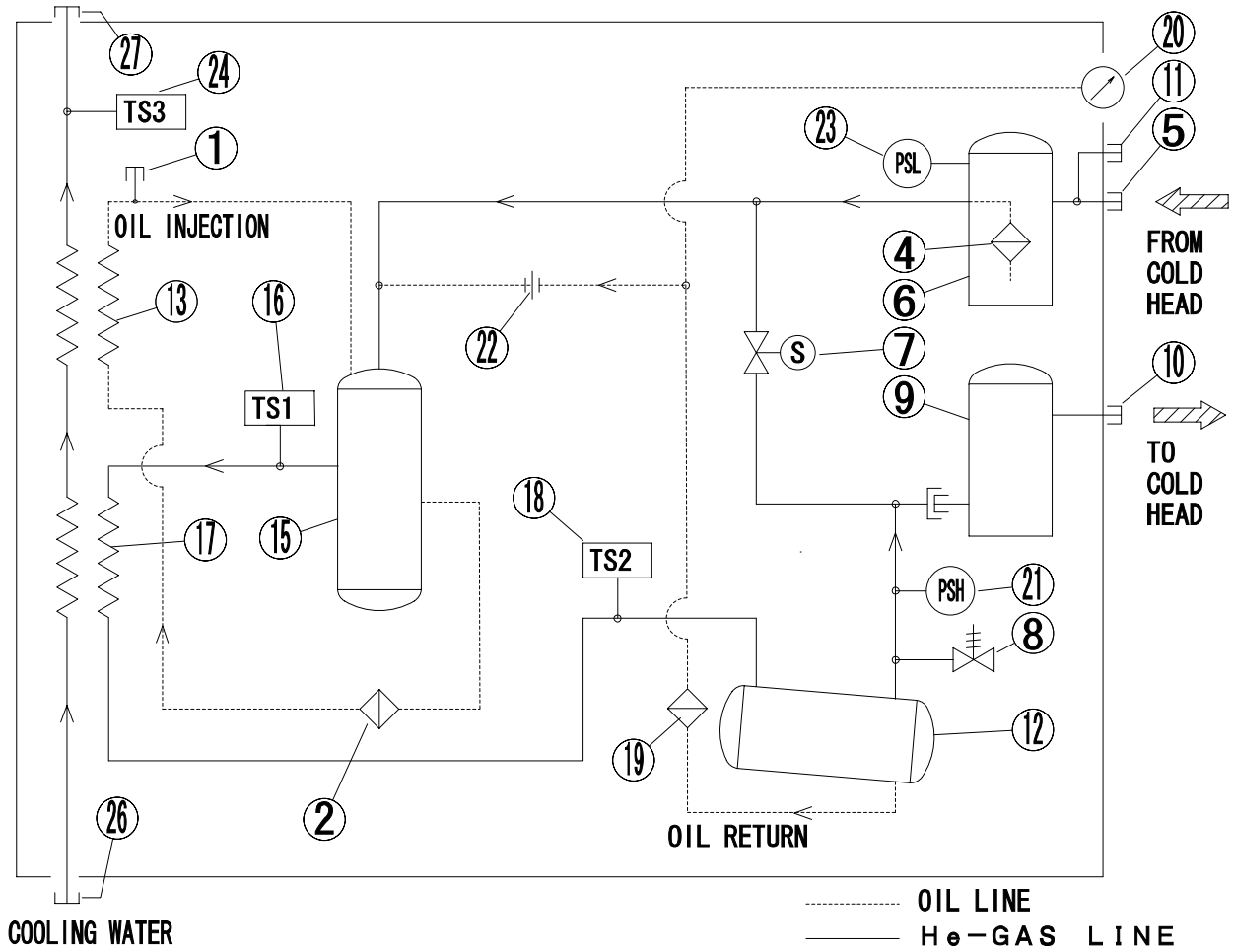

Figure 1.4 HELIUM GAS FLOW DIAGRAM FOR CSW-71D COMPRESSOR UNIT

## 1-2-3 INTERNAL COMPONENTS

The parts list and its functions are described in **Table 1.4**.

The He-gas flow diagram and internal components are shown in **Figure 1.4** and **Figure 1.5**.

**Table 1.4. FUNCTIONS OF THE INTERNAL COMPONENTS FOR CSW-71D COMPRESSOR UNIT**

No.	PARTS	FUNCTIONS
1	OIL CHARGE CONNECTOR	To use for refilling a lubricating oil.
2	FILTER	To eliminate contaminators and debris from a recirculating lub oil.
4	FILTER	To eliminate contaminators and debris from a He-gas suction for a Compressor Capsule.
5	HE-GAS RETURN CONNECTOR	To use for connecting a Flex Line (for Return He-gas line).
6	STORAGE TANK	A He-gas reservoir for piping to Compressor Capsule.
7	SOLENOID VALVE	An electro-magnetic operation valve for He-gas piping.
8	RELIEF VALVE	To keep a maximum high pressure for the He-gas piping safely.
9	ADSORBER	To use for eliminating a remained oil mist in the compressed He-gas after treatment by the Oil Separator.
10	HE-GAS SUPPLY CONNECTOR	To use for connecting a Flex Line (for Supply He-gas line).
11	HE-GAS CHARGE CONNECTOR	To use for charging and refilling a He-gas.
12	OIL SEPARATOR	To eliminate oil contamination from the compressed He-gas.
13	OIL COOLER	A water cooled type heat exchanger for recirculating lub oil.
15	COMPRESSOR CAPSULE	A He-gas compressed for the unit.
16	THERMOSTAT : TS1 110 deg.C (230 deg.F)	A thermal sensor & controller for the compressed He-gas temperature of compressor outlet.
17	HE-GAS COOLER	A water cooled type heat exchanger for compressed He-gas.
18	THERMOSTAT : TS2 60 deg.C (140 deg.F)	A thermal sensor & controller for the compressed He-gas temperature of He-gas cooler outlet.
19	FILTER	To eliminate contaminators and debris from a lub oil return of Oil Separator.
20	PRESSURE GAUGE	To indicate a filled He-gas pressure and compressed He-gas pressure of the unit.
21	HIGH SIDE PRESSURE SWITCH : PSH	A pressure sensor for compressed He-gas pressure control.
22	ORIFICE	To use for adjusting a recirculating lub oil flow.
23	LOW SIDE PRESSURE SWITCH : PSL	A pressure sensor for compressed He-gas pressure control.
24	THERMOSTAT : TS3 60 deg.C (140 deg.F)	A thermal sensor & controller for the water temperature of cooling water outlet.
26	COOLING WATER INLET CONNECTOR	To use for connecting a cooling water piping (for War Supply)
27	COOLING WATER OUTLET CONNECTOR	To use for connecting a cooling water piping (for Water Discharge)
28	CONTROL BOX	An electronic control, surveillance and alarming system for the He-gas Compressor Unit.

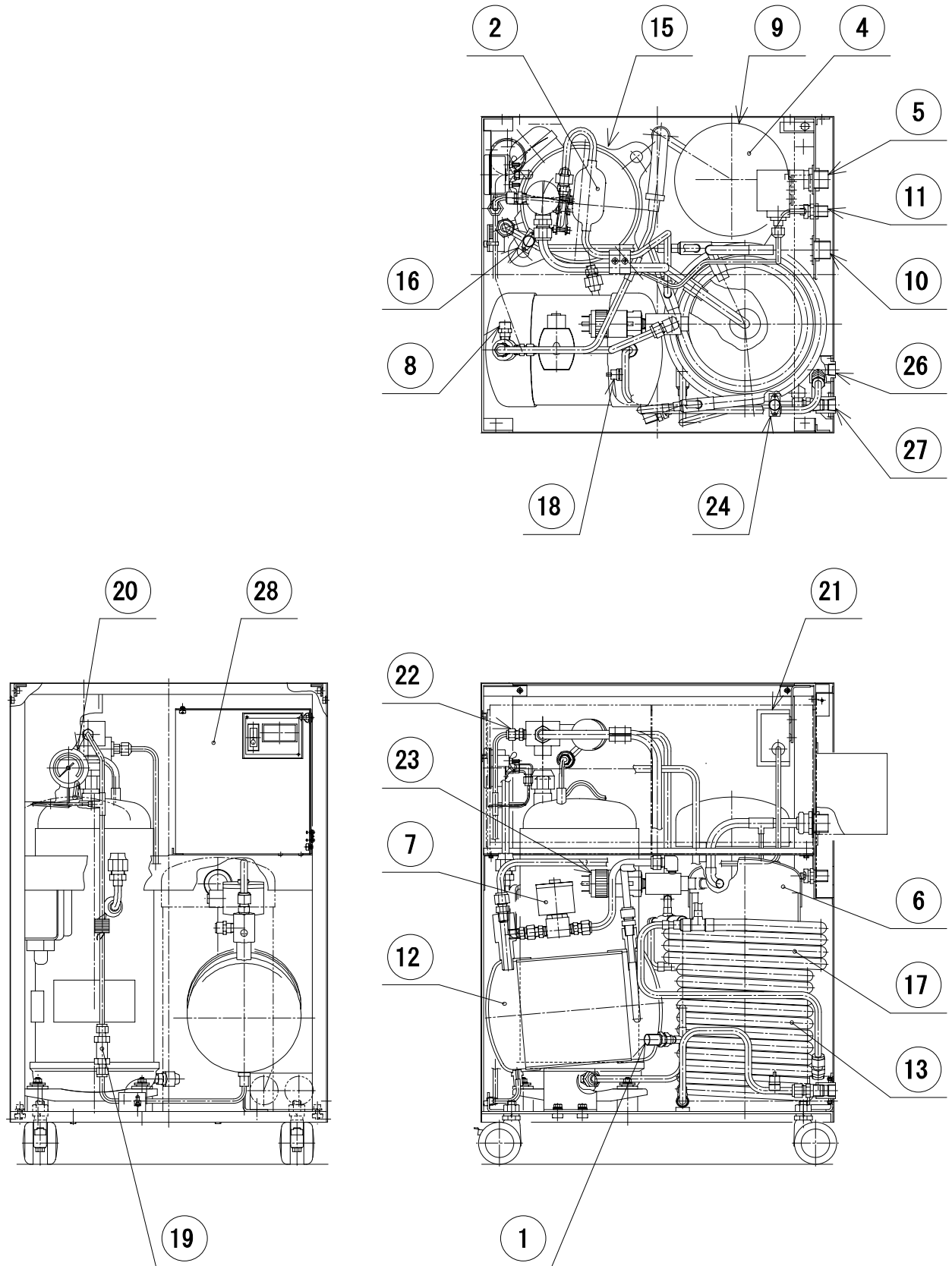



Figure 1.5 COMPONENTS OF CSW-71D COMPRESSOR UNIT

1-3 ELECTRICAL DESCRIPTION

1-3-1 EXTERNAL CONNECTOR

**WARNING**



**<Warning about electric shock>**

Pay special attention to its wiring when using the external connector on the compressor unit. Connecting a jumper wire between Pins No.6 - No.8, No.6 - No.13 and No.6 - No.15 may result in misoperation in some of safety devices in the equipment, causing electric shock, burn or malfunction.

This cryocooler includes a high-voltage section. Touching it may result in electric shock. Handle it with extreme care.

**"IMPORTANT"**

See the **"ELECTRICAL SCHEMATIC"** of CSW-71D Compressor Unit, for detail.

External Connector can be used monitoring the status of the Compressor Unit and the remote control sequences of the Compressor Unit are described in **Table 1.5**.

The "D-sub" pins indicated in **Figure 1.6** on the control panel for the Compressor Unit can be applied to an initial condition monitoring for a first-aid diagnostics of the Compressor Unit by means of measuring the each item with a digital Volt/Ohm Meter. The Fault Condition classified the digital meter reading as referred to the **Table 1.5** can be identified simply an actual operation condition of the Compressor Unit in the field.

**Table 1.5 EXTERNAL CONTROL / ALARM**

No.	ITEM	OPERATION		PIN No.	FAULT CONDITION*	
1	Pressure Alarm Signal	Contact	Normal	Close	1, 2	> 10 <sup>6</sup> ohm
			Alarm	Open		
2	Temp. Alarm Signal	Contact	Normal	Close	3, 4	> 10 <sup>6</sup> ohm
			Alarm	Open		
3	Drive Indication	DC Power	Operate	24V DC(0.15A max.)	6, 7	0 V
			Stop	0V		
4	Control Voltage	DC Power	Output 24V DC(0.15A max.), when Main Power SW is "ON"		7, 13	
5	Remote Reset	Relay	Pulsed 24VDC for 1 second to be furnished by user.		12, 14	
6	Remote Drive	Contact	Drive	Close	8, 15	
			Stop	Open		

\* Digital Volt./Ohm Meter Reading

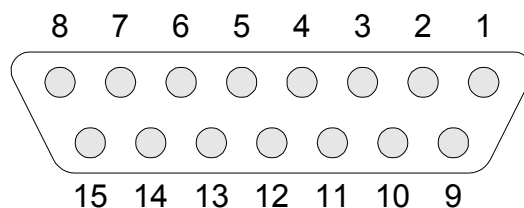

**Figure 1.6 EXTERNAL CONNECTOR WIRING ON THE COMPRESSOR UNIT**

1-3-2 SAFETY DEVICES

The safety devices list for Compressor Unit is shown in Table 1.6.

Table 1.6 SAFETY DEVICES OF CSW-71D

ITEM	FUNCTIONS
THERMOSTAT : (TS1)	Setting temperature; 110 deg.C (230 deg.F) ---- approx. To shut down the Compressor Unit and signal a high temperature alarm to the External Connector, in case of higher temperature of a compressed He-gas at a compressor outlet than the setting temperature.
THERMOSTAT : (TS2)	Setting temperature; 60 deg.C (140 deg.F) ---- approx. To shut down the Compressor Unit and signal a high temperature alarm to the External Connector, in case of higher temperature of a compressed He-gas at a He-gas cooler outlet than the setting temperature.
THERMOSTAT : (TS3)	Setting temperature; 60 deg.C (140 deg.F) ---- approx. To shut down the Compressor Unit and signal a higher temperature alarm to the External Connector, in case of higher temperature of a water at a cooling water outlet than the setting temperature.
SOLENOID VALVE : (YV)	To stabilize a pressure for even of the He-gas between the Supply and Return piping, at a shut off the Compressor Unit.
HIGH PRESSURE SWITCH : (PSH)	Setting pressure; "Operate" 2.55 MPa ---- approx. (26.0 kgf/cm <sup>2</sup> G, 369 psig) "Reset" 2.26 MPa ---- approx. (23.0 kgf/cm <sup>2</sup> G, 327 psig) To adjust a Supply He-gas pressure smoothly by a function of the pressure switch for Open and/or Shut, in case of higher pressure of the Supply He-gas than the setting pressure.
LOW PRESSURE SWITCH : (PSL)	Setting Pressure; "Operate" 0.15 MPa ---- approx. (1.5 kgf/cm <sup>2</sup> G, 22 psig) To shut down the Compressor Unit and signal a Low pressure alarm to the External Connector, in case of lower pressure of a compressed He-gas caused by a smaller quantity of He-gas than original filling in the compressor unit.
RELIEF VALVE	Setting pressure; "Operate" 2.61 - 2.75 MPa (26.6 - 28.0 kgf/cm <sup>2</sup> G, 378 - 398 psig) "Reset" 2.50 MPa ---- minimum (25.5 kgf/cm <sup>2</sup> G, 362 psig) To adjust a Supply He-gas pressure smoothly by a function of the Relief Valve for blowing off the He-gas to the atmosphere, in case of higher pressure of Supply He-gas than the setting pressure.
MAIN POWER SWITCH : (QF1)	Setting current; 13 A To shut down the Compressor Unit, in case of occurring over-current and/or short-circuit than the setting current.
PHASE FAILURE PROTECTION CIRCUIT :	To avoid starting-up of the Compressor Unit in case of an abnormal operation caused by irregular connecting of Input Power Cable such as failure connecting.
FUSE : (FU1, FU2, FU3, FU4)	To protect the Compressor Unit from the over-load caused by short-circuit and/or any other electrical failure in the DC power or the Solenoid Valve.

## 2 INSTALLATION

### 2-1 SITE REQUIREMENT

#### CAUTION



#### <Caution against misoperation>

Do not use inverter for the main power source of the compressor unit. Operating with inverter may result in the damage or malfunction of the compressor electric circuit.

Avoid using the transformer for the main power source of the compressor unit. If the transformer is installed at the upstream of the unit, lacking phase protection circuit with the cryocooler occurs in a malfunction. That may result in misoperation or malfunction. When using the transformer, install the other lacking phase protection device in upstream of the transformer.

Secure enough space around the compressor unit for heat radiation and maintenance. Failing to secure enough space may result in misoperation or malfunction.

Use cooling water with appropriate temperature, flow rate and water quality. Using inappropriate cooling water may result in misoperation or malfunction.

- An almost level and even area in the field will be selected to install the Compressor Unit.
- An area to be influenced by splashing water and/or dusts will not be selected to install the Compressor Unit installation area.
- A clean environmental condition without dirt and/or free from an exhausted heat will be selected to install the Compressor Unit in the field.
- A quality of cooling water will be secured to use for an appropriate coolant for the Compressor Unit.
- Any heat sensitive object cannot be positioned on surroundings of the Compressor Unit.

#### **AMBIENT TEMPERATURE CONDITION**

The ambient temperature must be between 5 deg.C (41 deg.F) and 28 deg.C (82.4 deg.F) to get the specified capacity. The system can operate up to 35 deg.C (95 deg.F) with less than 5% cooling capacity down. The maximum relative air humidity is 85%RH.

#### **HELIUM SUPPLY SYSTEM**

A helium supply system is necessary if you need to decontaminate the helium gas, or charging the helium gas that has leaked out of the system. A helium supply system includes a Grade 5 (99.999% up pure) helium gas bottle, a regulator, an outlet valve, and a charging hose or equivalent delivery line.

#### **POWER SOURCE**

Ensure the correct AC power source is available for the compressor. See **Table 1.1** for the power requirements for your system.

#### **COOLING WATER**

Ensure the correct cooling water is available for the compressor. See **Figure 1.1** and **Table 1.2.** for the cooling water requirements for your system.

#### **ANTIFREEZE**

Operating with Antifreeze (50/50 % mixture of water and ethylene glycol), the flow rate shall be larger than the water. See **Figure 1.1** and **Table 1.2.** for the cooling water requirements for your system.

#### **SAFETY / SEISMIC REQUIREMENT**

Secure to lock the locking device of compressor castor.

#### **SERVICE AREA**

The Compressor Unit should have enough space as shown in **Figure 2.1.**

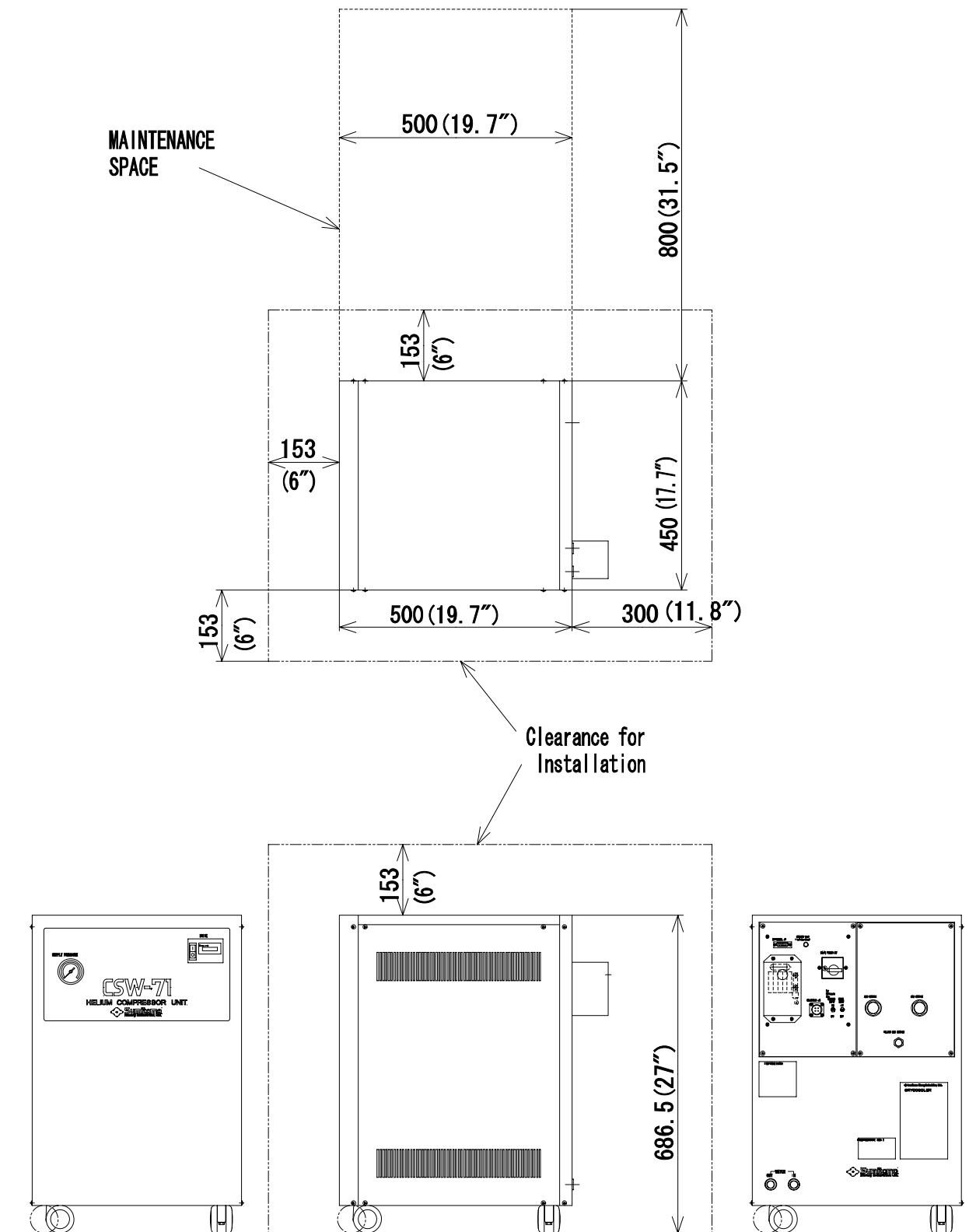



Figure 2.1 WATER-COOLED COMPRESSOR UNIT CSW-71D AND ITS REQUIRED SPACE

2-2 INPUT POWER CABLE CONNECTION

**WARNING**



**<Warning about electric shock>**  
 Make sure the power specification of the cryocooler used conforms to the customer's power supply before using the equipment. Using the cryocooler with a non-conforming power supply may result in electric shock or malfunction.

For CSW-71D compressor unit (water cooled, high voltage type), pay attention to the setting of the applicable input supply voltage. The product is shipped with the input supply voltage set to 480V. Before installing the equipment, be sure to check your supply voltage and change it to the appropriate setting if necessary. Operating the equipment with your supply voltage different from the setting of the compressor unit may result in electric shock or malfunction.

Be sure to turn off and Lock Out with OFF position the main power of the customer's power source before connecting or disconnecting the input power cable to the Compressor Unit, and then remove the input power cable from the main power. Failing to observe this precaution may result in electric shock.

Do not change the setting of the dial above the main power switch of the compressor unit under any circumstances. Failing to observe this precaution may result in electric shock.

**CAUTION**



**<Caution against misoperation>**  
 Do not use inverter for the main power source of the compressor unit. Operating with inverter may result in the damage or malfunction of the compressor electric circuit.

Avoid using the transformer for the main power source of the compressor unit. If the transformer is installed at the upstream of the unit, lacking phase protection circuit with the cryocooler occurs in a malfunction. That may result in misoperation or malfunction. When using the transformer, install the other lacking phase protection device in upstream of the transformer.

**“IMPORTANT”**

**This cryocooler is provided with a phase reverse protection circuit for the input power. If the input power is connected with reverse phase, the cryocooler does not start.**

**“IMPORTANT”**

**See “ELECTRICAL SCHEMATIC” of CSW-71D Compressor Unit, for detail.**

**“IMPORTANT”**

**See “INPUT POWER CABLE HV” of “APPENDIX” for detail.**

Make electrical connection as follows;

**Upstream Protection**

Use the fuses or circuit breakers as upstream protection of L1, L2, L3. The recommended rating of the protection is maximum 30A.

**Power Supply Conductor and Protective Earth Conductor**

Use 75 deg.C wiring sized to 60 deg.C ampacity.  
 Use copper conductor only. AWG 12 (3.3 mm<sup>2</sup>) or larger.

**Compressor Unit Side**

*Power Supply Conductors*  
 Striping Length: 12 mm  
 Tightening Torque: 1.3 N·m (13 kgf·cm)

*Protective Earth Conductor*  
 Striping Length: 12 mm  
 Tightening Torque: 1.8 N·m (18 kgf·cm)

**User's Power Source Side**

*Power Supply Conductors*  
 Striping Length: 12 mm

*Protective Earth Conductor*  
 Striping Length: 12 mm

2-2 INPUT POWER CABLE CONNECTION

See the Table 1.1 for power requirements. The cables are marked with label and connect as follows:

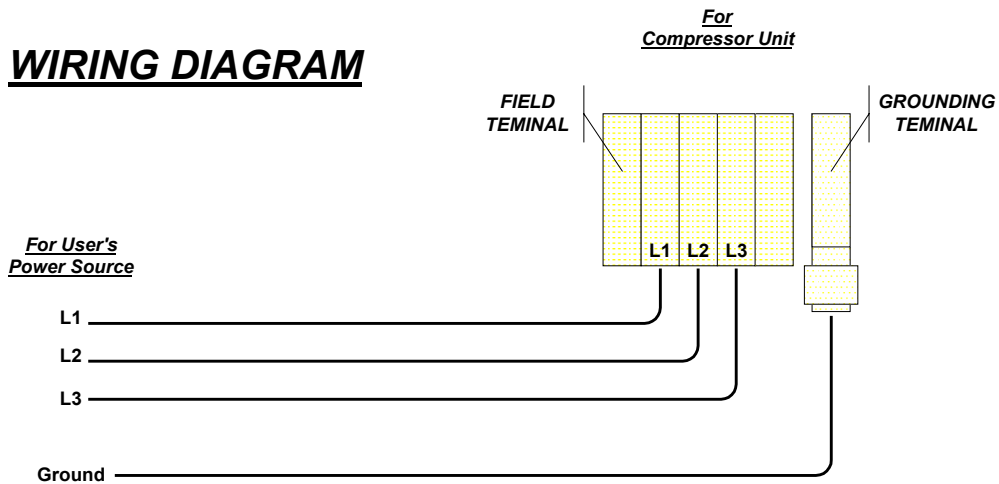

**Input Power Voltage Setting**

The Compressor Unit can be operated on various input power voltages by changing the terminal wiring in the Compressor Unit. This terminal is located inside of the Control Box. See the Figure 2.2 for voltage setting. **Initial factory setting is AC480V / 60Hz.**

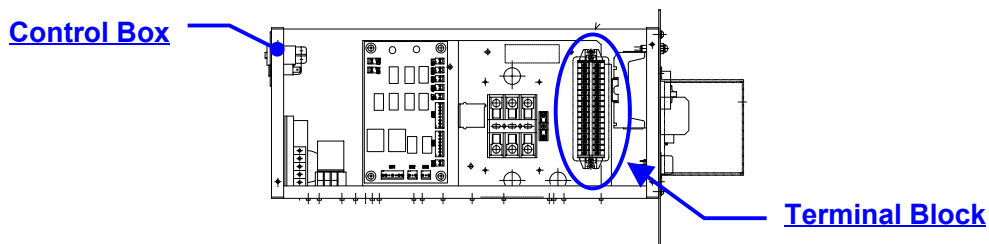

Position of Wire Connection				
480V at 60Hz	460V at 60Hz	415V at 50Hz	400V at 50Hz	380V at 50Hz

Figure 2.2 TERMINAL WIRING FOR INPUT POWER VOLTAGE

## 3 MAINTENANCE

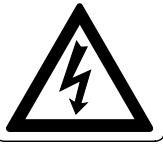
**WARNING****<Warning about electric shock>**

This cryocooler includes a high-voltage section. Touching it may result in electric shock. Handle it with extreme care.

Make sure no power is applied to the compressor unit before starting operation when connecting or disconnecting the cold head power cable. Failing to observe this precaution may result in electric shock.

Be sure to turn off and Lock Out with OFF position the main power of the customer's power source before connecting or disconnecting the input power cable to the Compressor Unit, and then remove the input power cable from the main power. Failing to observe this precaution may result in electric shock.

Do not change the setting of the dial above the main power switch of the compressor unit under any circumstances. Failing to observe this precaution may result in electric shock.

Be sure to turn off and Lock Out with OFF position the customer's main power before performing maintenance work such as replacement of fuses. Failing to observe this precaution may result in electric shock.

**WARNING****<Warning about explosion, escape of gas>**

This cryocooler (cold head, compressor unit, compressor adsorber, flex lines) contains a high-pressure (about 1.62 MPa (16.5 kgf/cm<sup>2</sup>G, 235 psig)) helium gas sealed in. Hitting the equipment with a sharp edge or touching it with a pointed object may cause explosion or escape of gas. Handle the equipment with extreme care.

Do not disassemble the equipment for purposes other than maintenance specified in this service manual under any circumstances. Disassembling the equipment may result in electric shock, explosion or escape of gas.

**CAUTION****<Caution against misoperation>**

Do not get on the compressor unit or put an object on top of it. Failing to observe this precaution may prevent the cryocooler from operating normally or cause injury.

Secure enough space around the compressor unit for heat radiation and maintenance. Failing to secure enough space may result in misoperation or malfunction.

Use cooling water with appropriate temperature, flow rate and water quality. Using inappropriate cooling water may result in misoperation or malfunction.

The cold head drive switch provided with the compressor unit is only used for maintenance. Be sure to turn it OFF in normal operation. Using the compressor unit with the cold head drive switch turned ON may result in misoperation or malfunction.

**3-1 PERIODICAL MAINTENANCE**

CSW-71D Compressor Unit is to be required the routine maintenance. The basic maintenance work is to replace the oil mist Adsorber of the Compressor Unit for every 20,000 Hrs operation as mentioned **Table 3.1**.

**Table 3.1 MAINTENANCE SCHEDULE**

<b>MAINTENANCE</b>	<b>FREQUENCY</b>	<b>REMARK</b>
Replace Compressor Adsorber	Every 20,000 Hrs.	
Charge Helium Gas to Compressor	As required	
Cleaning Water Cooler	As required	Depending on the water conditions.
Compressor Fuse Replacement	As required	

**Table 3.2 RENEWAL PARTS LIST (FRU'S)**

<b>ITEM</b>	<b>DESCRIPTION</b>	<b>Q'TY</b>	<b>DIMENSIONS</b>	<b>PART NUMBER</b>
1	Adsorber	1	OD155 x H447	RE71TN0408
2	Class G Fuse 1A	3		RE71WT0768
3	Glass Body Fuse 1A	1		RE71WT0767
4	Hose Nipple	2	12 x 3/8	RE38VT0689

3-1-1 REPLACEMENT OF THE COMPRESSOR ADSORBER

**WARNING**



**<Warning about explosion, escape of gas>**

This cryocooler (cold head, compressor unit, compressor adsorber, flex lines) contains a high-pressure (about 1.62 MPa (16.5 kgf/cm<sup>2</sup>G, 235 psig)) helium gas sealed in. Hitting the equipment with a sharp edge or touching it with a pointed object may cause explosion or escape of gas. Handle the equipment with extreme care.

Do not disassemble the equipment for purposes other than maintenance specified in this service manual under any circumstances. Disassembling the equipment may result in electric shock, explosion or escape of gas.

The cold head, compressor unit, compressor adsorber and flex lines are pressurized with helium gas. Purge the helium gas from all pressurized components before disposing. Open the purging valve gradually or it may result in serious injury.

**WARNING**



The Adsorber weight is about 11.0kg. Be careful of handling so that it may not get hurt when replace the adsorber.

**CAUTION**



**<Caution against misoperation>**

Do not get on the compressor unit or put an object on top of it. Failing to observe this precaution may prevent the cryocooler from operating normally or cause injury.

The Oil Mist Adsorber is required to replace for every 20,000 Hrs operation.

**Table 3.3 ADSORBER FOR COMPRESSOR UNIT**

	DESCRIPTION	Q'TY	PART NUMBER	REMARK
1	Adsorber	1	RE71TN0408	OD155 x H447

**Table 3.4 REQUIRED TOOLS FOR ADSORBER REPLACEMENT**

	TOOLS	REMARK
1	1" open-end wrench	For Aero-quip coupling
2	1-1/8" Open-end wrench	For Aero-quip coupling
3	1-3/16" Open-end wrench	For Aero-quip coupling
4	Snoop liquid	For leak check
5	Cotton wipers	For leak check
6	13 mm Open-end wrench	For fixing nut for Adsorber
7	Screw driver (phillips(+))	For side panel of Compressor Unit.

Replace the Adsorber instructed as follows;

**PREPARATION**

- 1) Shut down the Cryocooler.
- 2) Disconnect the Input Power Cable from the Compressor Unit.
- 3) Disconnect the Supply and Return Flex Lines from the Compressor Unit.

**REMOVING THE USED ADSORBER**

- 1) Loosen the screws that hold the compressor side panel and remove the panel.



- 2) Disconnect the Adsorber Self-Sealing Coupling. Use three wrenches.



- 3) Remove the Nut secured the Adsorber to Rear Panel. Use two wrenches.



- 4 ) Remove the Nut and Washer secured the Adsorber to the base panel of the Compressor Unit.

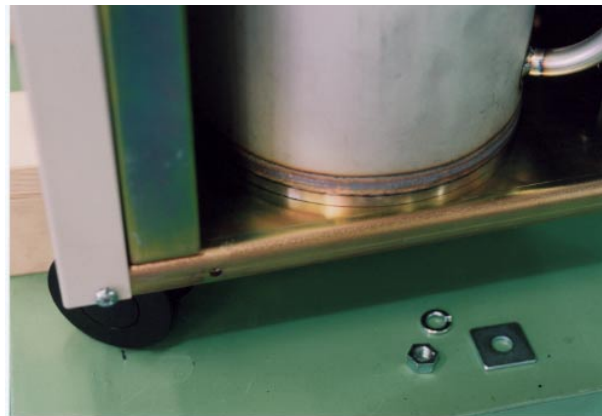

- 5 ) Remove the used Adsorber from the Compressor frame.



**INSTALLING NEW ADSORBER**

- 1) Set a new Adsorber.
- 2) Secure the Adsorber to the base panel of the Compressor Unit by tightened Nut and Washer.
- 3) Secure the Adsorber to Rear Panel by tightening Nut.
- 4) Connect the Adsorber Self-Sealing Coupling.
- 5) Reinstall the panels and secure them by tightening the screws.
- 6) Ensure that the pressure gauge indication is specified value for the type of Cold Head. Charge helium gas, in case of low pressure indicating.

3-2 FUSE REPLACEMENT

	<p><b>&lt;Warning about electric shock&gt;</b>                  This cryocooler includes a high-voltage section. Touching it may result in electric shock. Handle it with extreme care.</p> <p>Be sure to turn off the customer's main power before performing maintenance work such as replacement of fuses, and remove the input power cable from the compressor unit. Failing to observe this precaution may result in electric shock.</p>
---	---

Fuses are equipped inside of the Fuse Box for the Control Box.

Table 3.5 LIST OF FUSES

Fuse No.	Description	Part Number	Remarks
FU1, 2, 3	Class G Fuse 1A	RE71WT0768	For Cold Head Motor, Solenoid Valve and DC Circuit.
FU4	Glass Body Fuse 1A	RE71WT0767	

**FUSE REPLACING PROCEDURE**

- 1) Loosen the screws that hold the compressor side panel, and remove the panel.
- 2) Replace the Fuses.

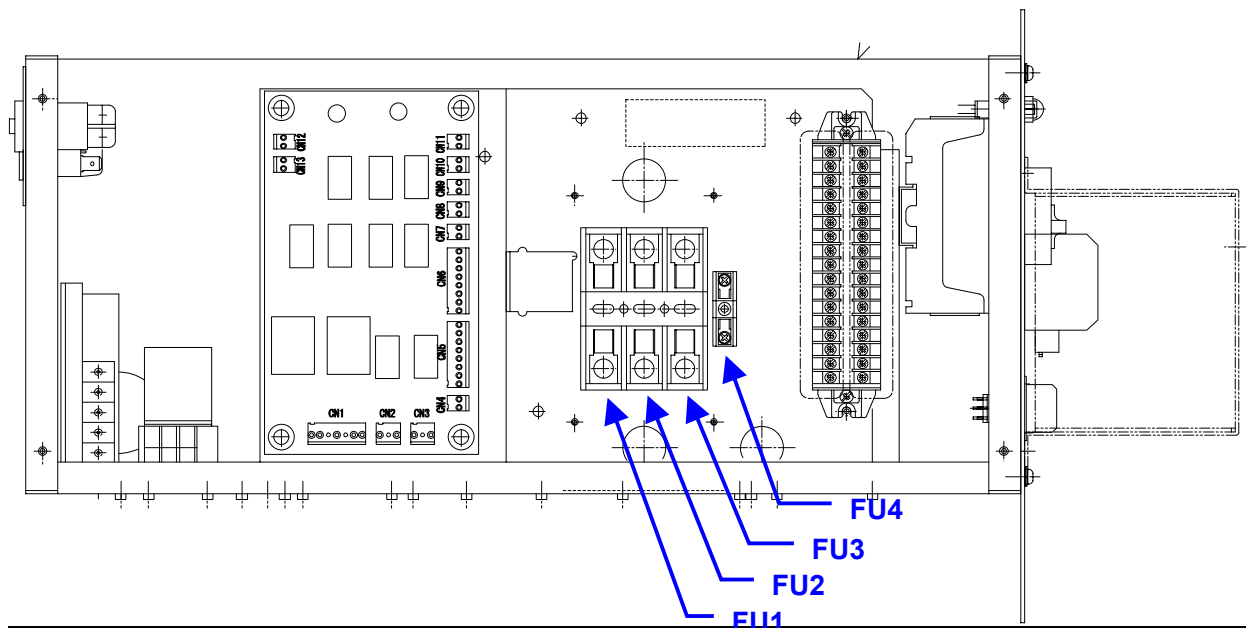

**APPENDIX****ELECTRICAL SCHEMATIC**

No.	PART NAME
1	ELECTRICAL SCHEMATIC of CSW-71D (FOR AC CIRCUIT)
2	ELECTRICAL SCHEMATIC of CSW-71D (FOR DC CIRCUIT)

**DRAWINGS**

No.	PART NAME
1	ADSORBER
2	CLASS G FUSE 1A
3	GLASS BODY FUSE 1A
4	INPUT POWER CABLE HV

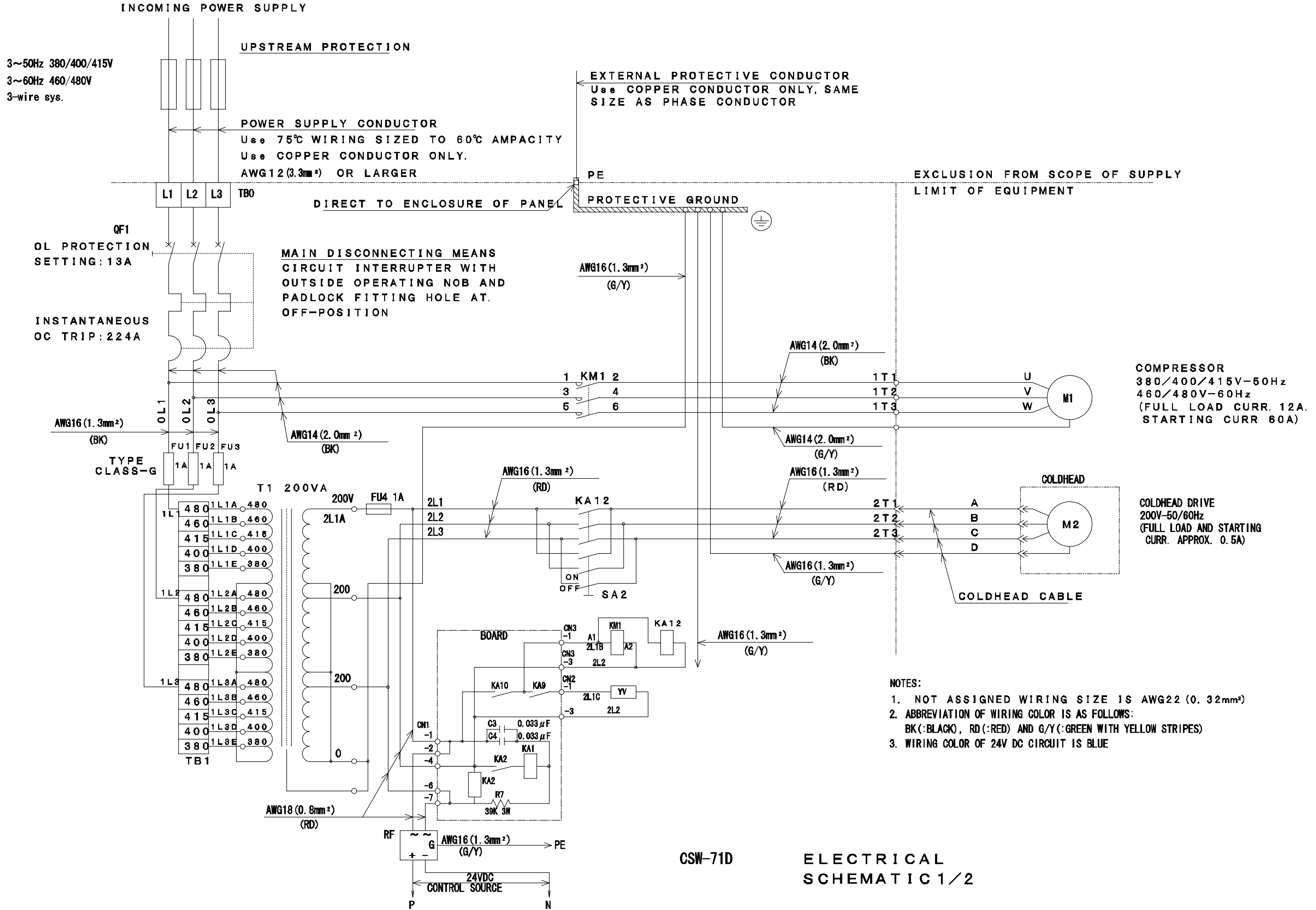

CSW-71D

**ELECTRICAL**  
**SCHEMATIC 1/2**

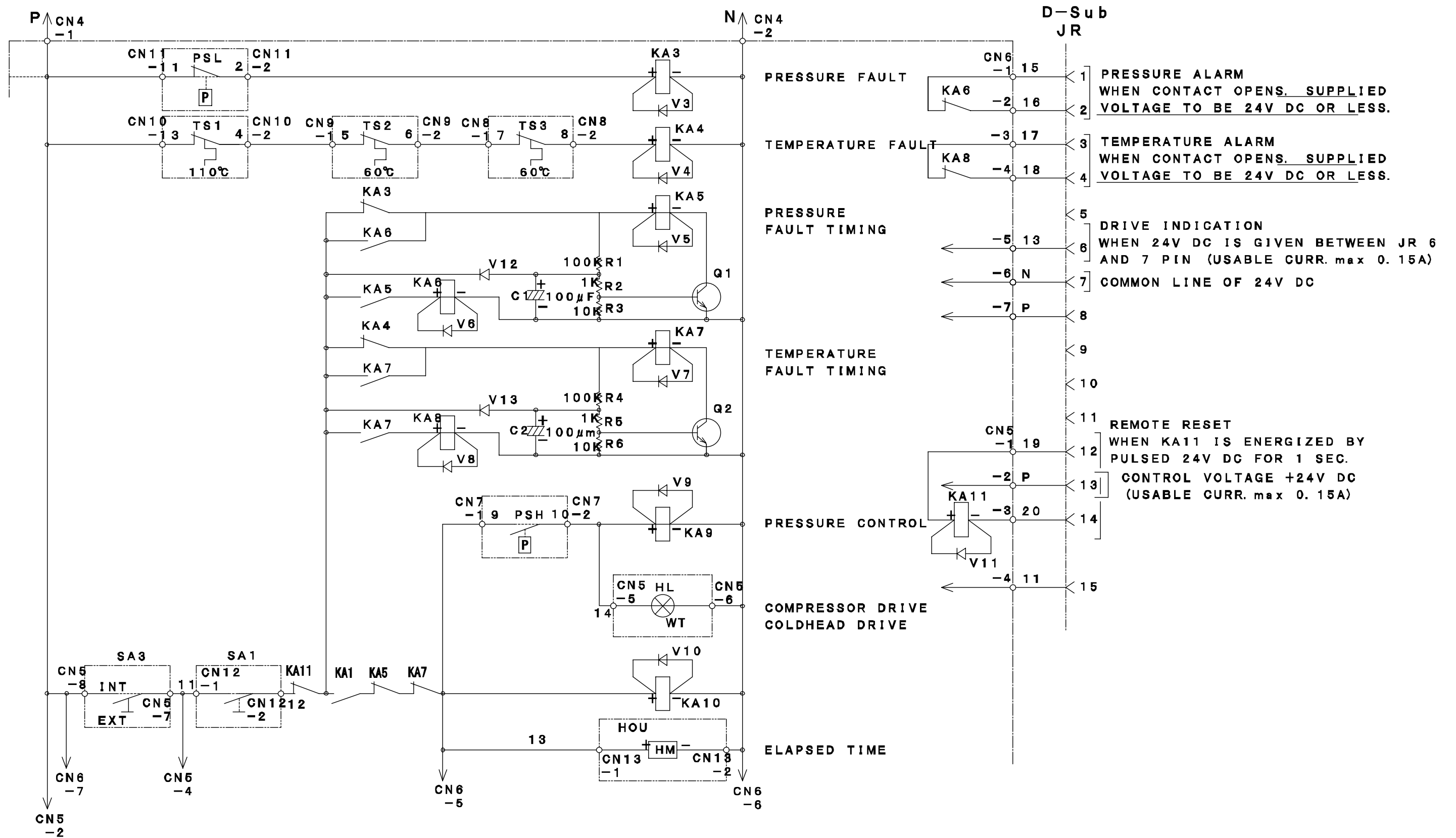

CSW71C/D ELECTRICAL SCHEMATIC 2/2

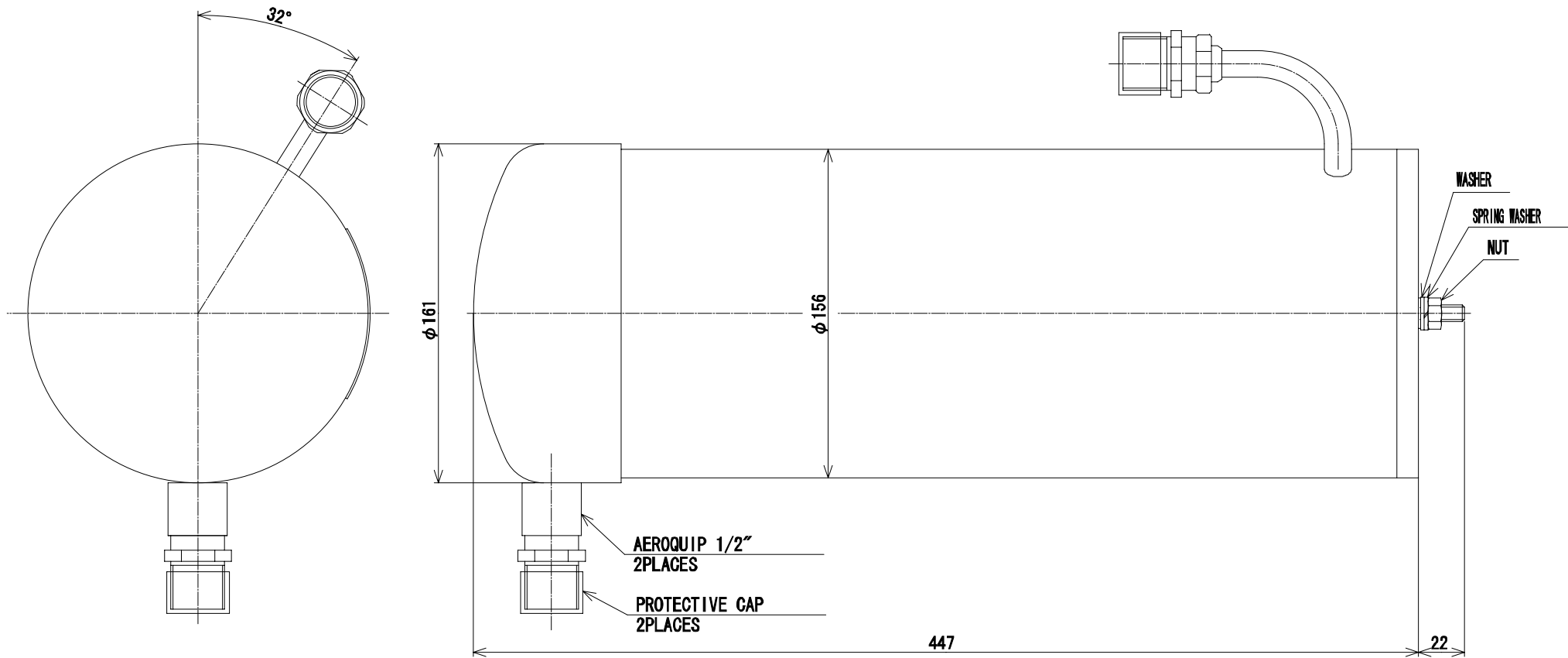

**NOTE**

- (1) CHARGED HELIUM GAS 16.5 kg (Cm 62MPa).
- (2) WEIGHT 11 kg.

**ADSORBER**

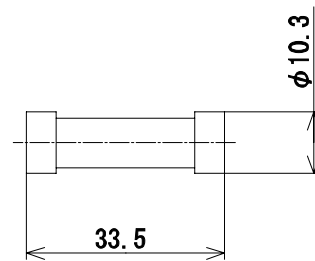

**NOTE**

1. CLASS G.
2. CURRENT RATING 1A.

**CLASS G FUSE 1A**

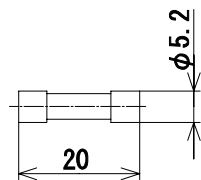

**NOTE**

1. CURRENT RATING 1A.

**GLASS BODY FUSE 1A**

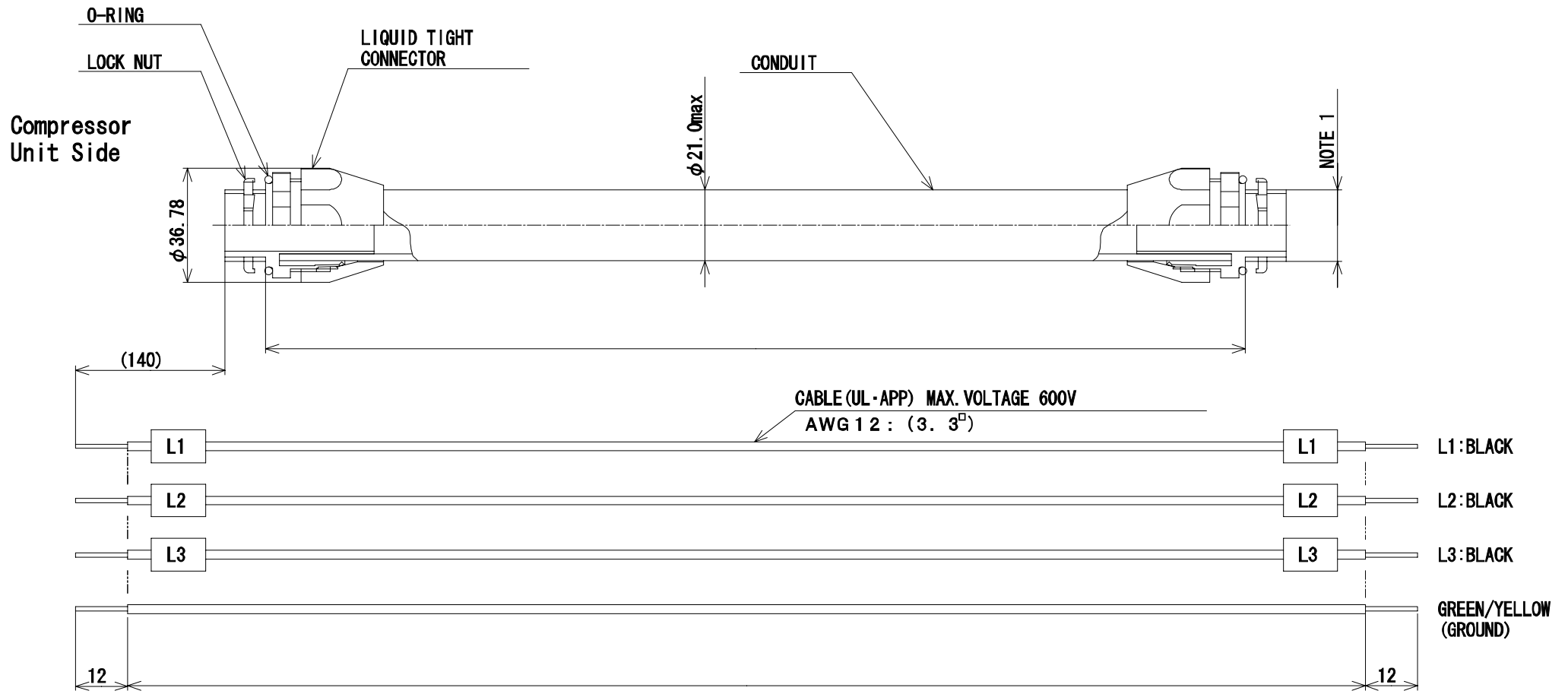

**NOTE**

- (1) HOLE SIZE : MIN  $\phi 22mm$ .
- (2) PART TO BE BAGGED OR BOXED AND SEALED FROM DIRT AND MOISTURE.

**INPUT POWER CABLE HV  
CSW-71D**

**REVISION CONTROL**

<b>Manual No.</b>	<b>Revision</b>	<b>Remarks</b>	<b>Date</b>
CD32ZZ-208	-A	Publication of first edition.	JAN. 12 / 2006