

GE Healthcare

Optima MR360/Brivo MR355 Block Diagrams & Supplemental Schematics

Technical Publication



DAMAGE IN TRANSPORTATION

All packages should be closely examined at time of delivery. If damage is apparent, have notation “**damage in shipment**” written on **all** copies of the freight or express bill **before** delivery is accepted or “signed for” by a General Electric representative or a hospital receiving agent. Whether noted or concealed, damage **MUST** be reported to the carrier **immediately** upon discovery, or in any event, within **14** days after receipt, and the contents and containers held for inspection by the carrier. A transportation company will not pay a claim for damage if an inspection is not requested within this **14** day period.

File a report with

- Call 1–800–548–3366 and use option 8.
- Contact your local service coordinator for more information on this process.

Rev. 08/15/2003

© 2006, General Electric Company
GE Medical Systems, a General Electric Company, going to market as GE Healthcare
3200 N. Grandview Boulevard
Waukesha, Wisconsin 53188
USA

www.gehealthcare.com



WARNING

- THIS SERVICE MANUAL IS AVAILABLE IN ENGLISH ONLY.
- IF A CUSTOMER'S SERVICE PROVIDER REQUIRES A LANGUAGE OTHER THAN ENGLISH, IT IS THE CUSTOMER'S RESPONSIBILITY TO PROVIDE TRANSLATION SERVICES.
- DO NOT ATTEMPT TO SERVICE THE EQUIPMENT UNLESS THIS SERVICE MANUAL HAS BEEN CONSULTED AND IS UNDERSTOOD.
- FAILURE TO HEED THIS WARNING MAY RESULT IN INJURY TO THE SERVICE PROVIDER, OPERATOR OR PATIENT FROM ELECTRIC SHOCK, MECHANICAL OR OTHER HAZARDS.

AVERTISSEMENT

- CE MANUEL DE MAINTENANCE N'EST DISPONIBLE QU'EN ANGLAIS.
- SI LE TECHNICIEN DU CLIENT A BESOIN DE CE MANUEL DANS UNE AUTRE LANGUE QUE L'ANGLAIS, C'EST AU CLIENT QU'IL INCOMBE DE LE FAIRE TRADUIRE.
- NE PAS TENTER D'INTERVENTION SUR LES ÉQUIPEMENTS TANT QUE LE MANUEL SERVICE N'A PAS ÉTÉ CONSULTÉ ET COMPRIS.
- LE NON-RESPECT DE CET AVERTISSEMENT PEUT ENTRAÎNER CHEZ LE TECHNICIEN, L'OPÉRATEUR OU LE PATIENT DES BLESSURES DUES À DES DANGERS ÉLECTRIQUES, MÉCANIQUES OU AUTRES.

WARNUNG

- DIESES KUNDENDIENST-HANDBUCH EXISTIERT NUR IN ENGLISCHER SPRACHE.
- FALLS EIN FREMDER KUNDENDIENST EINE ANDERE SPRACHE BENÖTIGT, IST ES AUFGABE DES KUNDEN FÜR EINE ENTSPRECHENDE ÜBERSETZUNG ZU SORGEN.
- VERSUCHEN SIE NICHT, DAS GERÄT ZU REPARIEREN, BEVOR DIESES KUNDENDIENST-HANDBUCH ZU RATE GEZOGEN UND VERSTANDEN WURDE.
- WIRD DIESE WARNUNG NICHT BEACHTET, SO KANN ES ZU VERLETZUNGEN DES KUNDENDIENSTTECHNIKERS, DES BEDIENERS ODER DES PATIENTEN DURCH ELEKTRISCHE SCHLÄGE, MECHANISCHE ODER SONSTIGE GEFAHREN KOMMEN.

AVISO

- ESTE MANUAL DE SERVICIO SÓLO EXISTE EN INGLÉS.
- SI ALGÚN PROVEEDOR DE SERVICIOS AJENO A GEMS SOLICITA UN IDIOMA QUE NO SEA EL INGLÉS, ES RESPONSABILIDAD DEL CLIENTE OFRECER UN SERVICIO DE TRADUCCIÓN.
- NO SE DEBERÁ DAR SERVICIO TÉCNICO AL EQUIPO, SIN HABER CONSULTADO Y COMPRENDIDO ESTE MANUAL DE SERVICIO.
- LA NO OBSERVANCIA DEL PRESENTE AVISO PUEDE DAR LUGAR A QUE EL PROVEEDOR DE SERVICIOS, EL OPERADOR O EL PACIENTE SUFRAN LESIONES PROVOCADAS POR CAUSAS ELÉCTRICAS, MECÁNICAS O DE OTRA NATURALEZA.

ATENÇÃO

- ESTE MANUAL DE ASSISTÊNCIA TÉCNICA SÓ SE ENCONTRA DISPONÍVEL EM INGLÊS.
- SE QUALQUER OUTRO SERVIÇO DE ASSISTÊNCIA TÉCNICA, QUE NÃO A GEMS, SOLICITAR ESTES MANUAIS NOUTRO IDIOMA, É DA RESPONSABILIDADE DO CLIENTE FORNECER OS SERVIÇOS DE TRADUÇÃO.
- NÃO TENDE REPARAR O EQUIPAMENTO SEM TER CONSULTADO E COMPREENDIDO ESTE MANUAL DE ASSISTÊNCIA TÉCNICA.
- O NÃO CUMPRIMENTO DESTE AVISO PODE POR EM PERIGO A SEGURANÇA DO TÉCNICO, OPERADOR OU PACIENTE DEVIDO A' CHOQUES ELÉTRICOS, MECÂNICOS OU OUTROS.

AVVERTENZA

- IL PRESENTE MANUALE DI MANUTENZIONE È DISPONIBILE SOLTANTO IN INGLESE.
- SE UN ADDETTO ALLA MANUTENZIONE ESTERNO ALLA GEMS RICHIEDE IL MANUALE IN UNA LINGUA DIVERSA, IL CLIENTE È TENUTO A PROVVEDERE DIRETTAMENTE ALLA TRADUZIONE.
- SI PROCEDA ALLA MANUTENZIONE DELL'APPARECCHIATURA SOLO DOPO AVER CONSULTATO IL PRESENTE MANUALE ED AVERNE COMPRESO IL CONTENUTO.
- NON TENERE CONTO DELLA PRESENTE AVVERTENZA POTREBBE FAR COMPIERE OPERAZIONI DA CUI DERIVINO LESIONI ALL'ADDETTO ALLA MANUTENZIONE, ALL'UTILIZZATORE ED AL PAZIENTE PER FOLGORAZIONE ELETTRICA, PER URTI MECCANICI OD ALTRI RISCHI.

警告

- ・このサービスマニュアルには英語版しかありません。
- ・GEMS以外でサービスを担当される業者が英語以外の言語を要求される場合、翻訳作業はその業者の責任で行うものとさせていただきます。
- ・このサービスマニュアルを熟読し理解せずに、装置のサービスを行わないで下さい。
- ・この警告に従わない場合、サービスを担当される方、操作員あるいは患者さんが、感電や機械的又はその他の危険により負傷する可能性があります。

注意:

- 本维修手册仅存有英文本。
- 非 GEMS 公司的维修员要求非英文本的维修手册时，客户需自行负责翻译。
- 未详细阅读和完全了解本手册之前，不得进行维修。
- 忽略本注意事项会对维修员，操作员或病人造成触电，机械伤害或其他伤害。

REV 1

REVISION HISTORY

REV	DATE	PRIMARY REASON FOR CHANGE
1.....	Aug 20, 2010	Initial Release

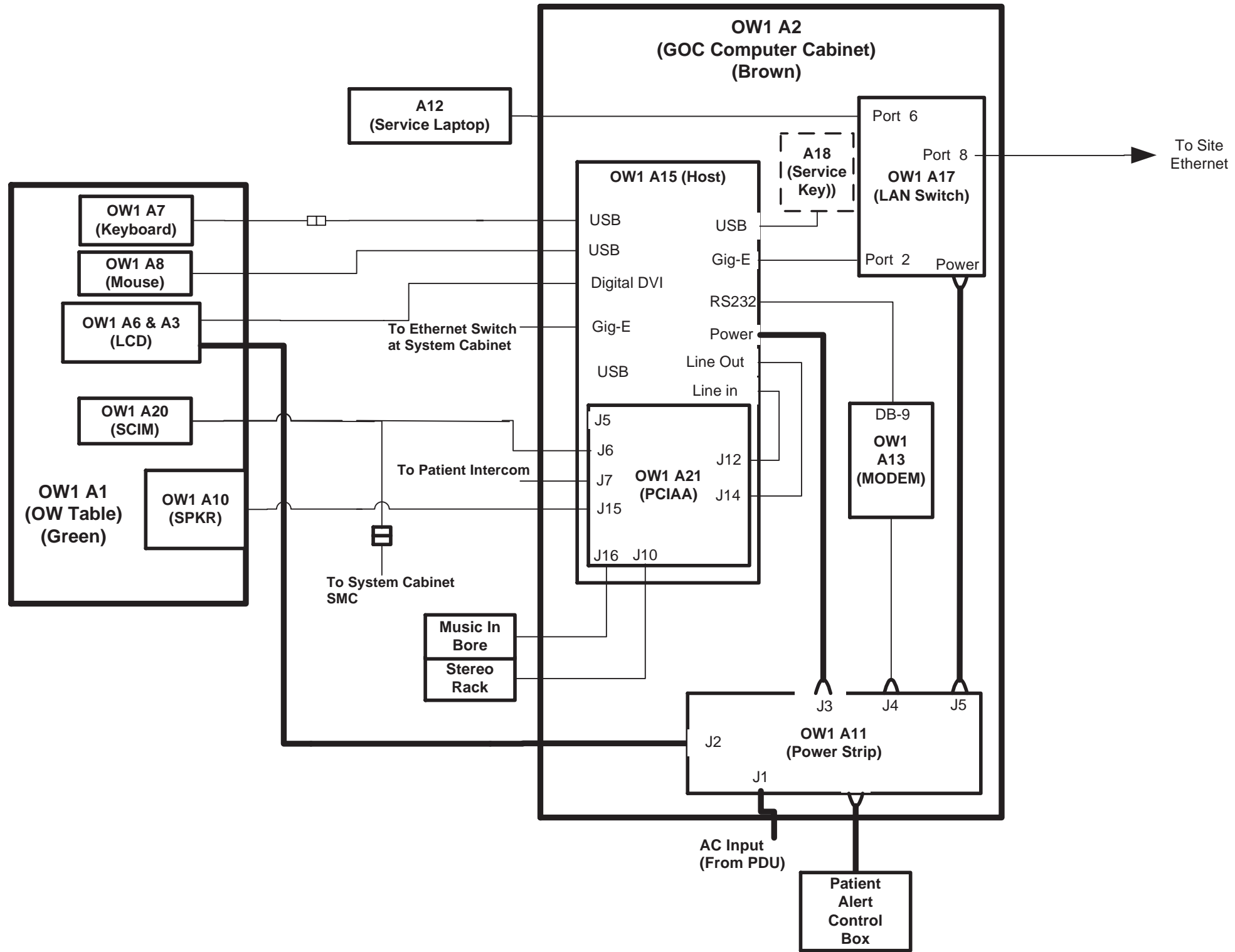

NOTES:

- 1 Network connection available for external suite connection
- 2 network connection available at front of goc assembly for the service laptop

Refer to the following functional block diagram for additional information:

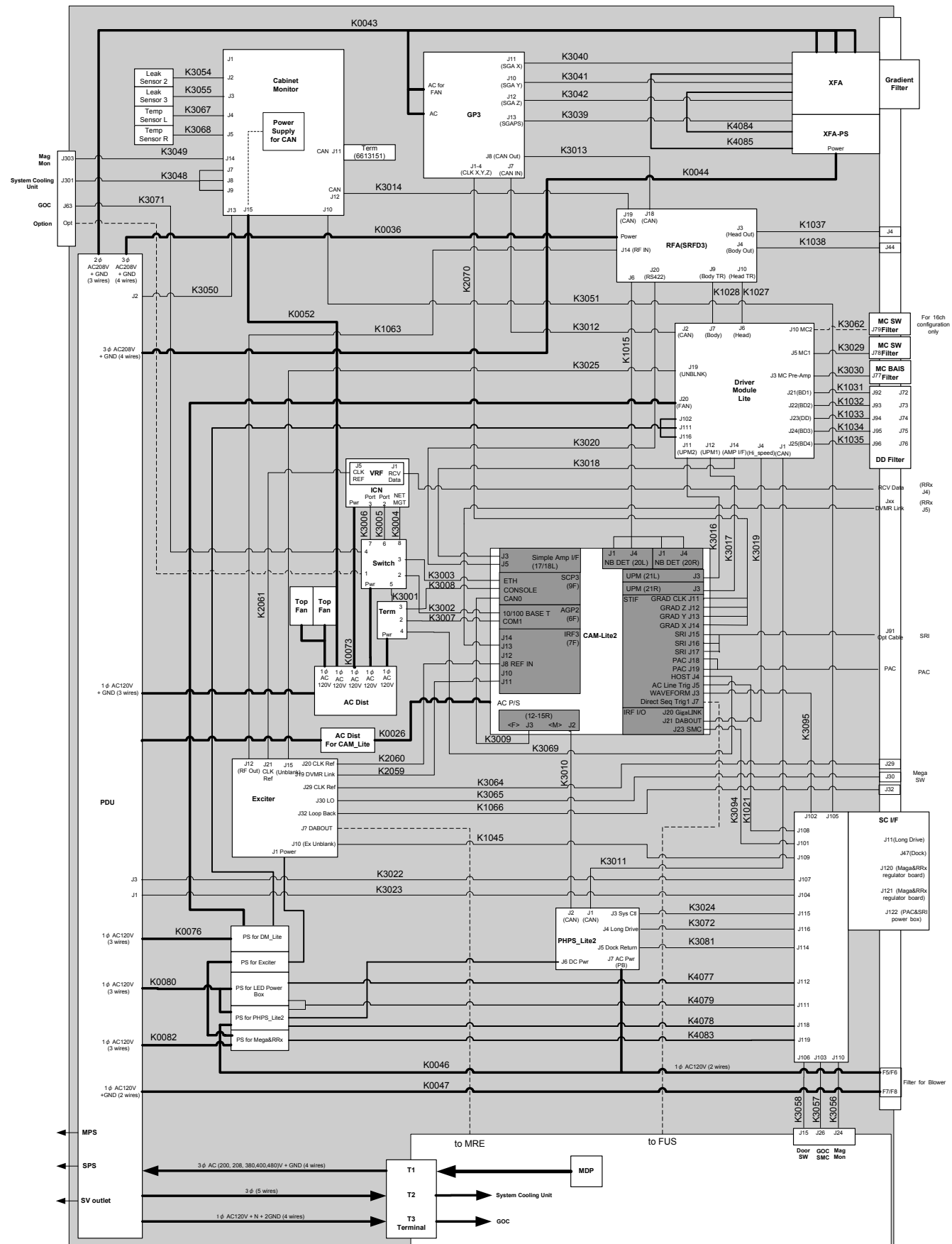

All dash lines are for option

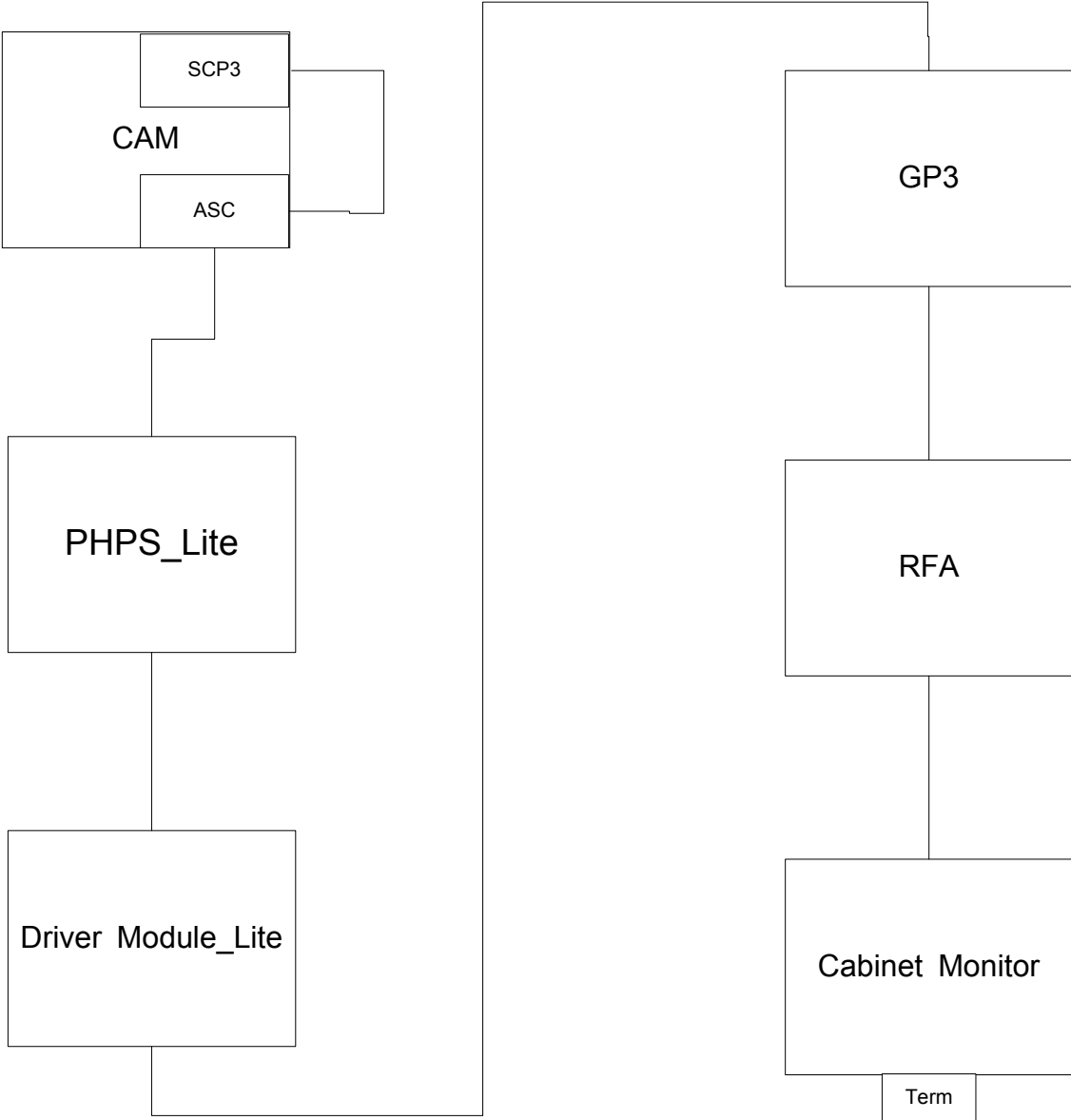

CAN LOOP

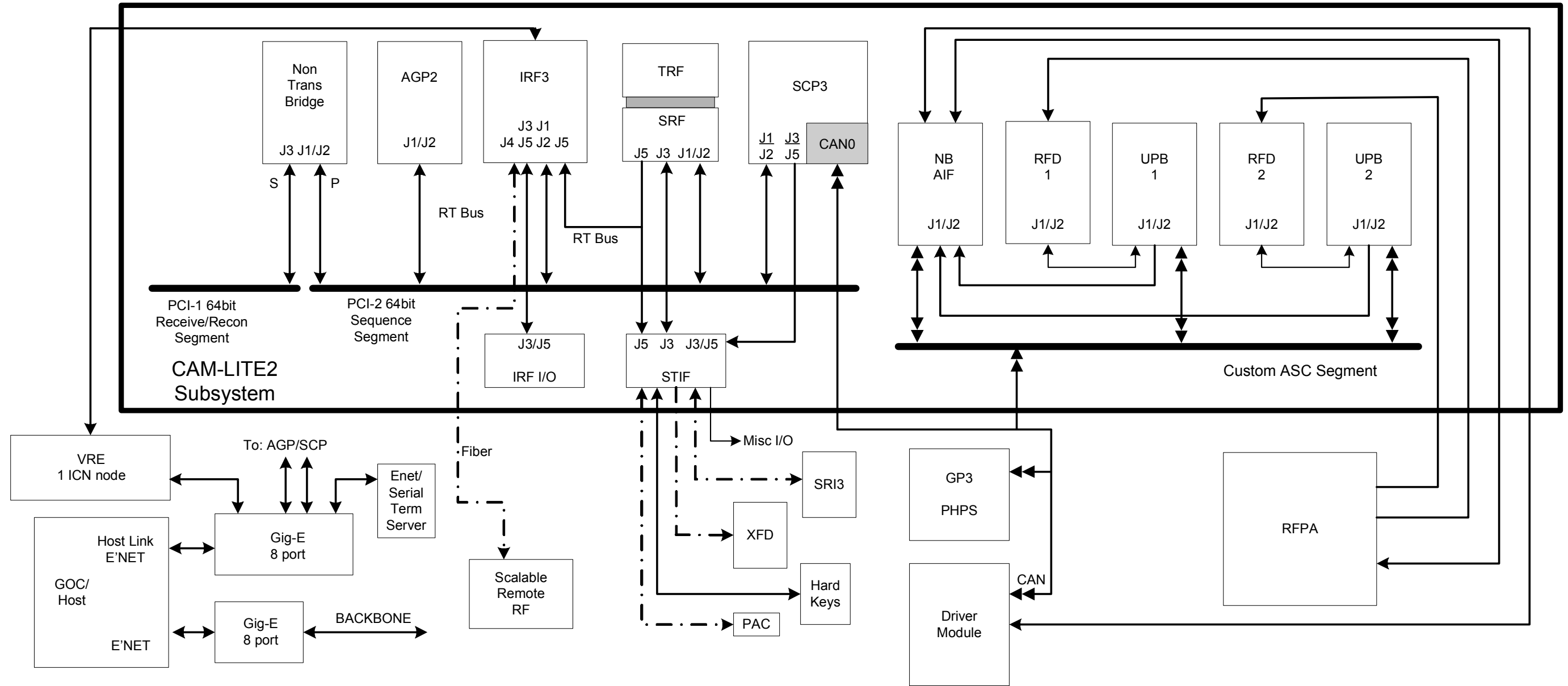

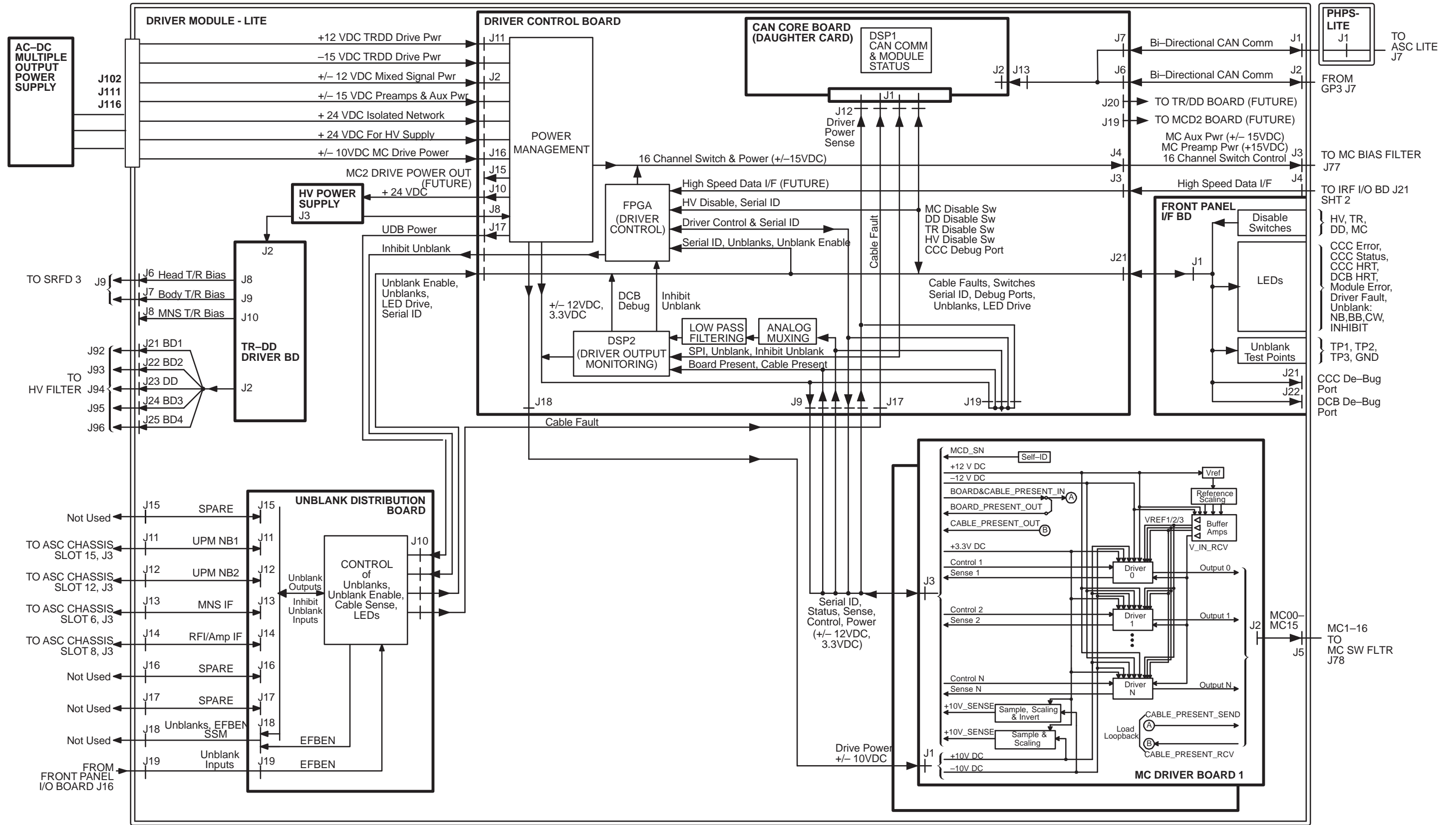

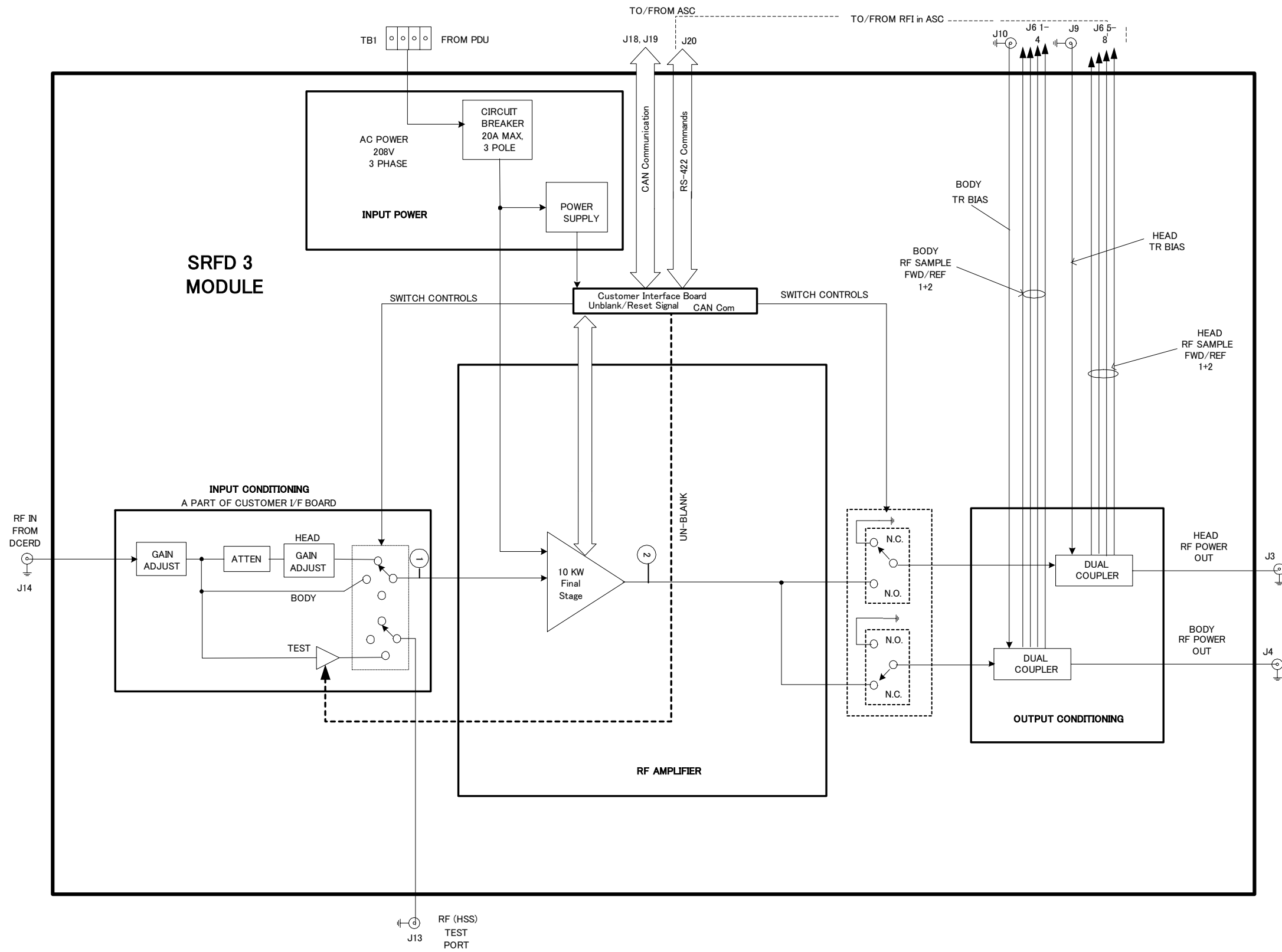

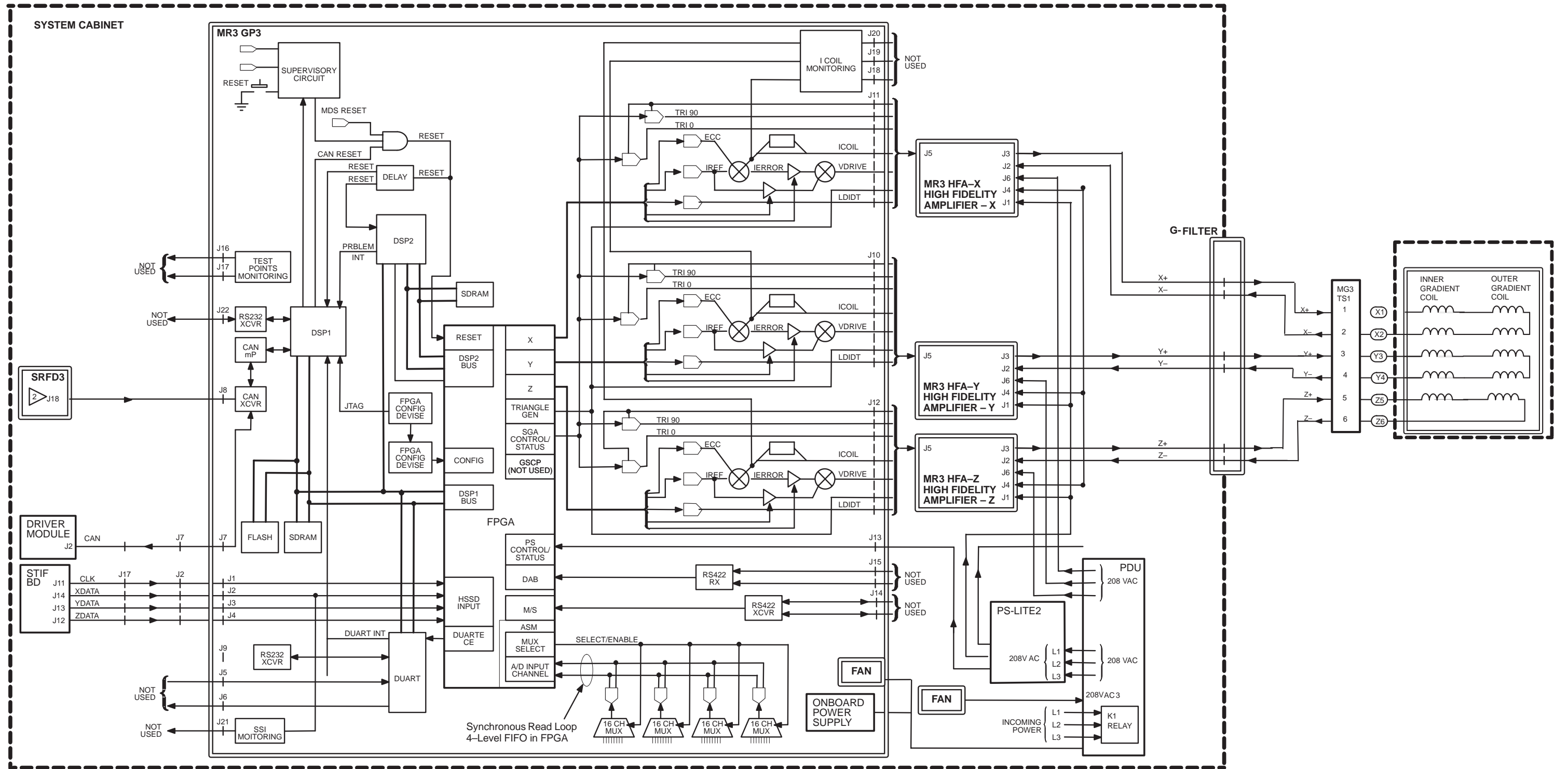

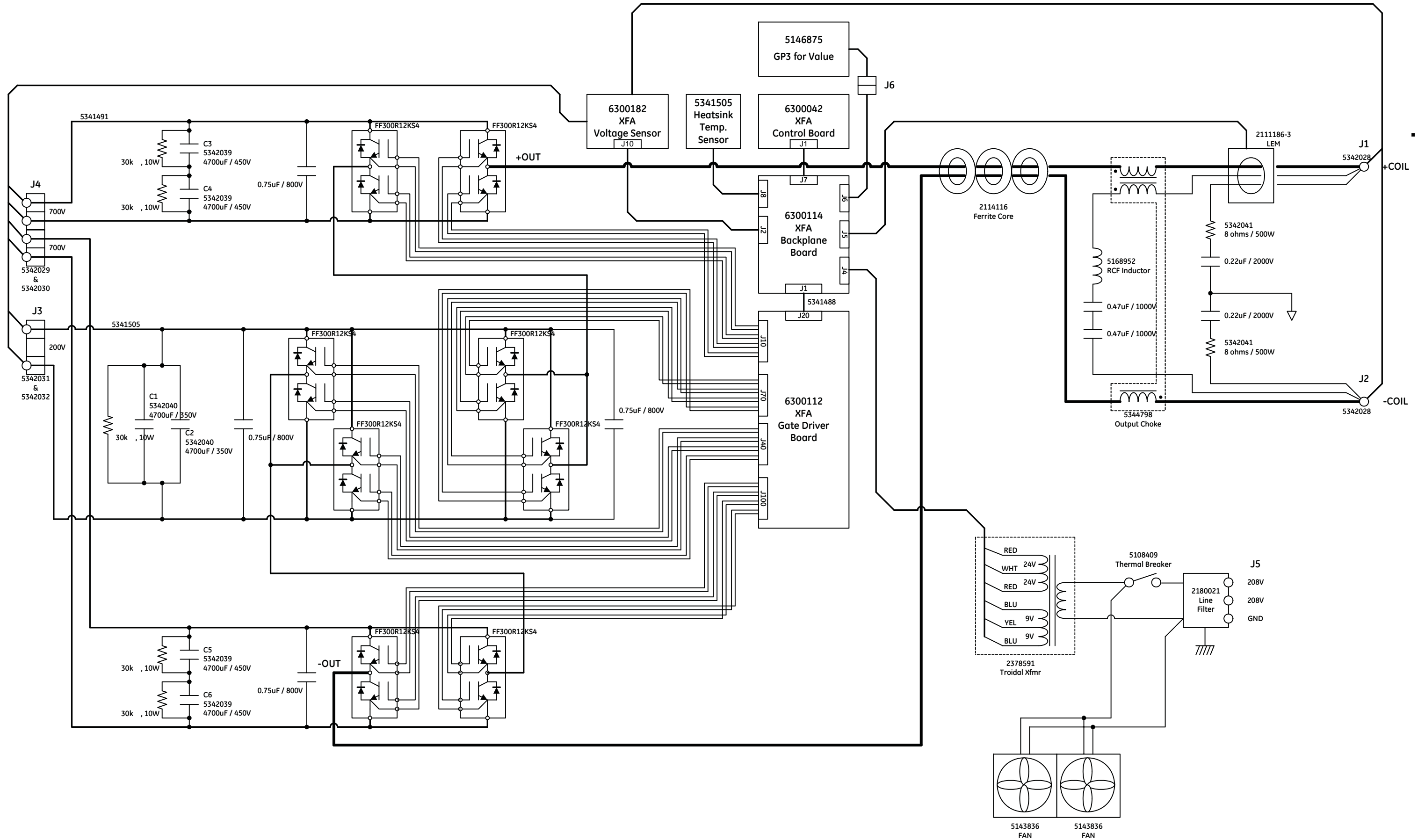

SYSTEM CABINET - XFA

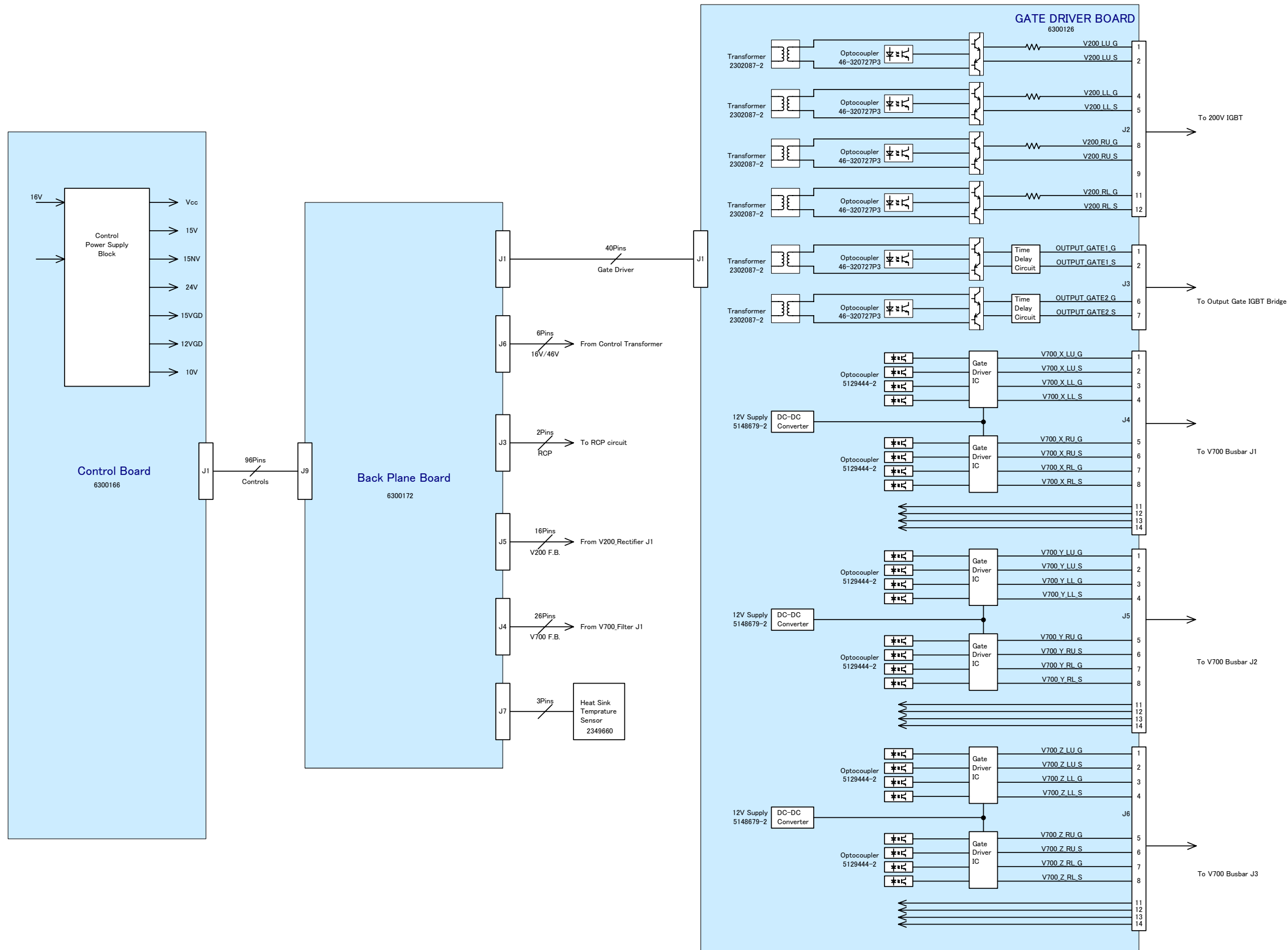

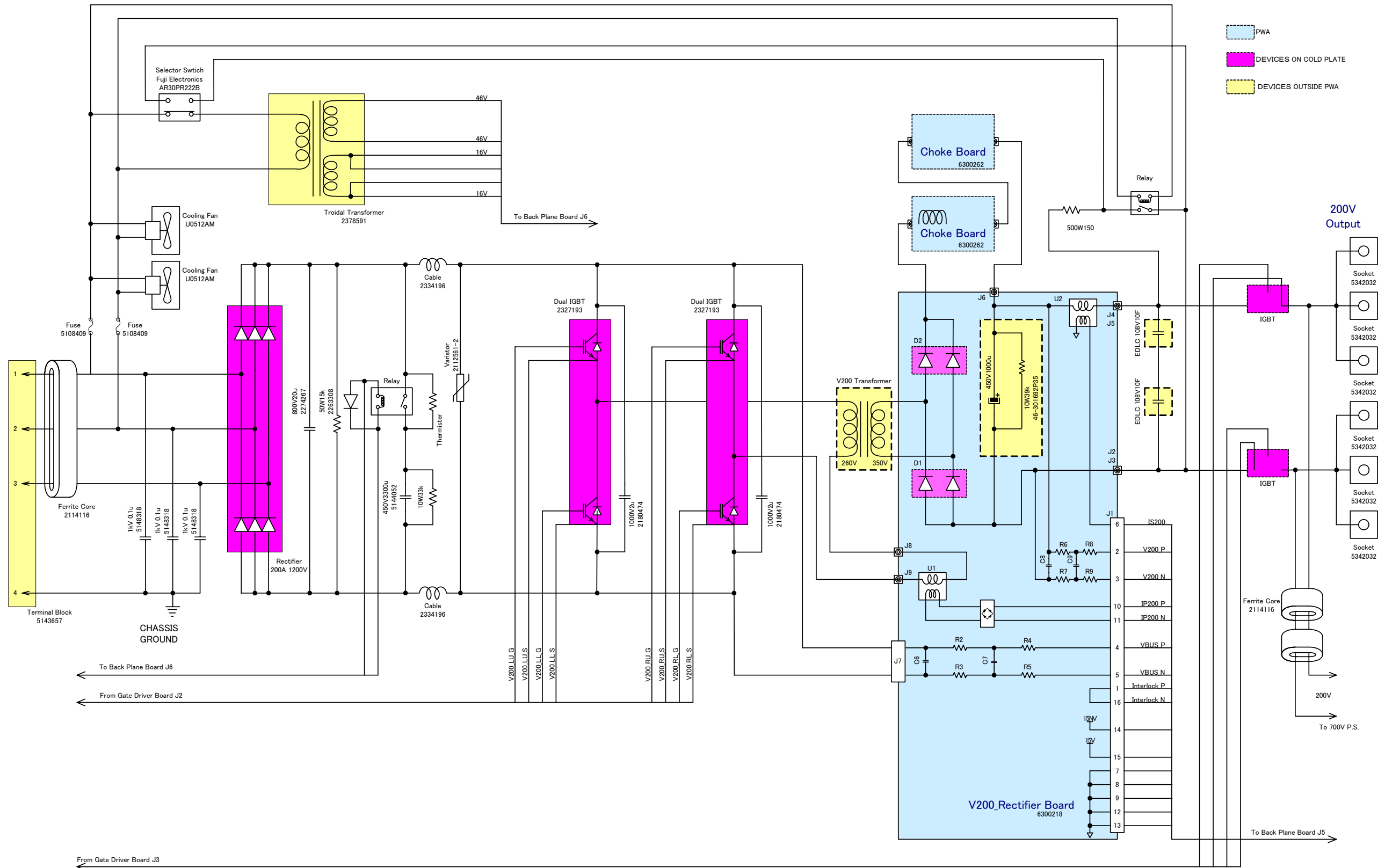

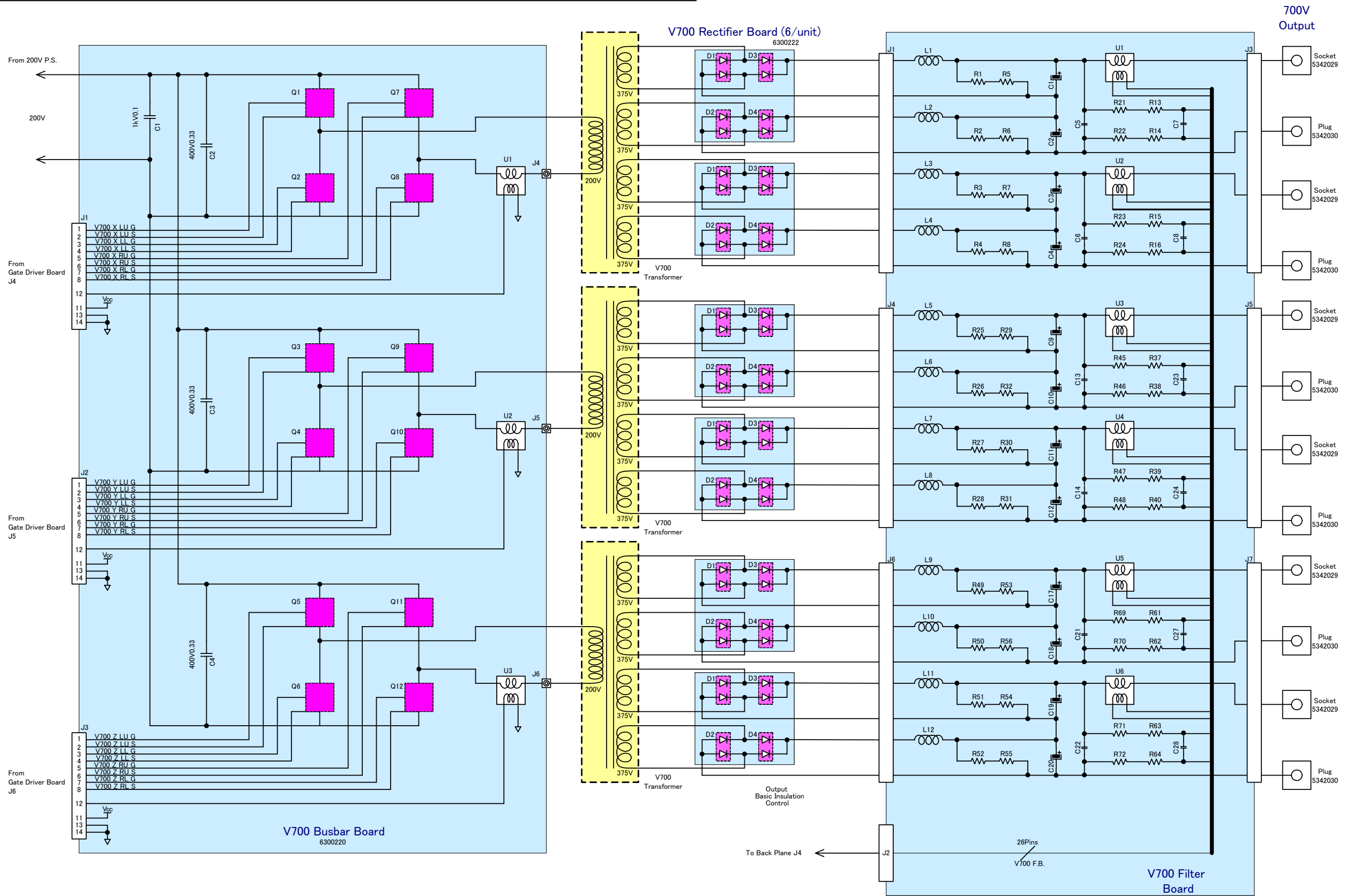

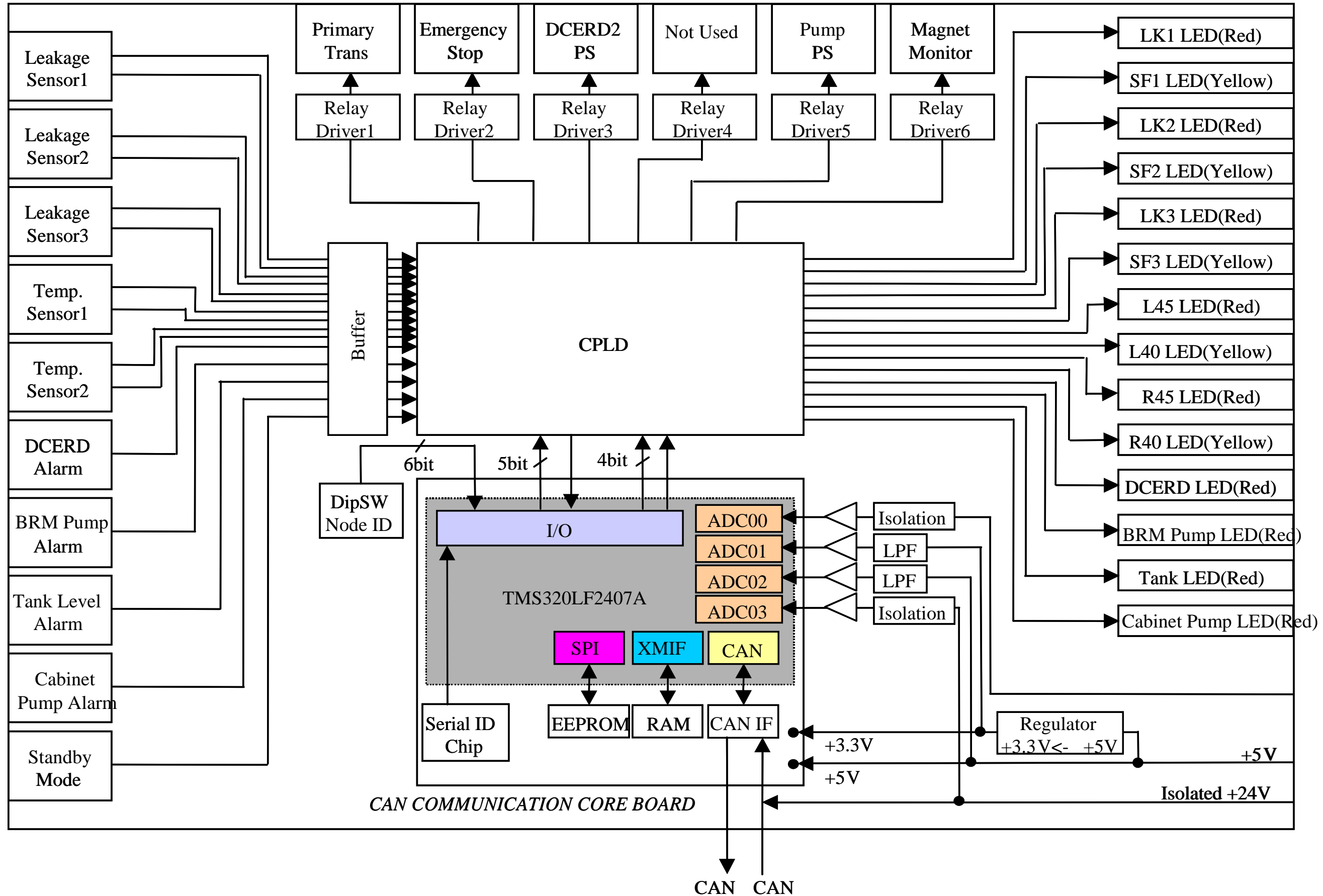

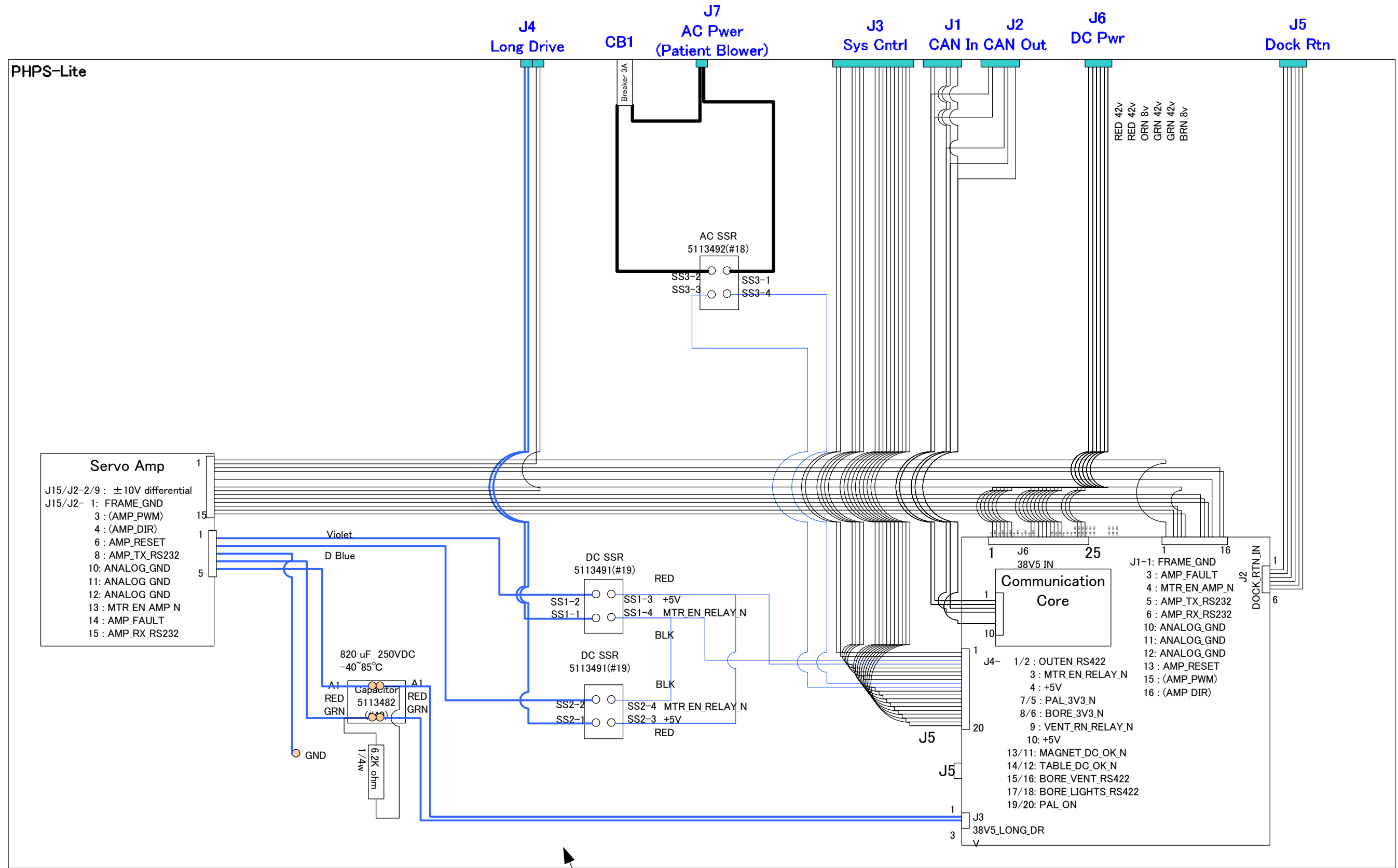

#25 5138536
L=540

Amp #350766-1
MATE-N-LOK 3pin Plug
Socket

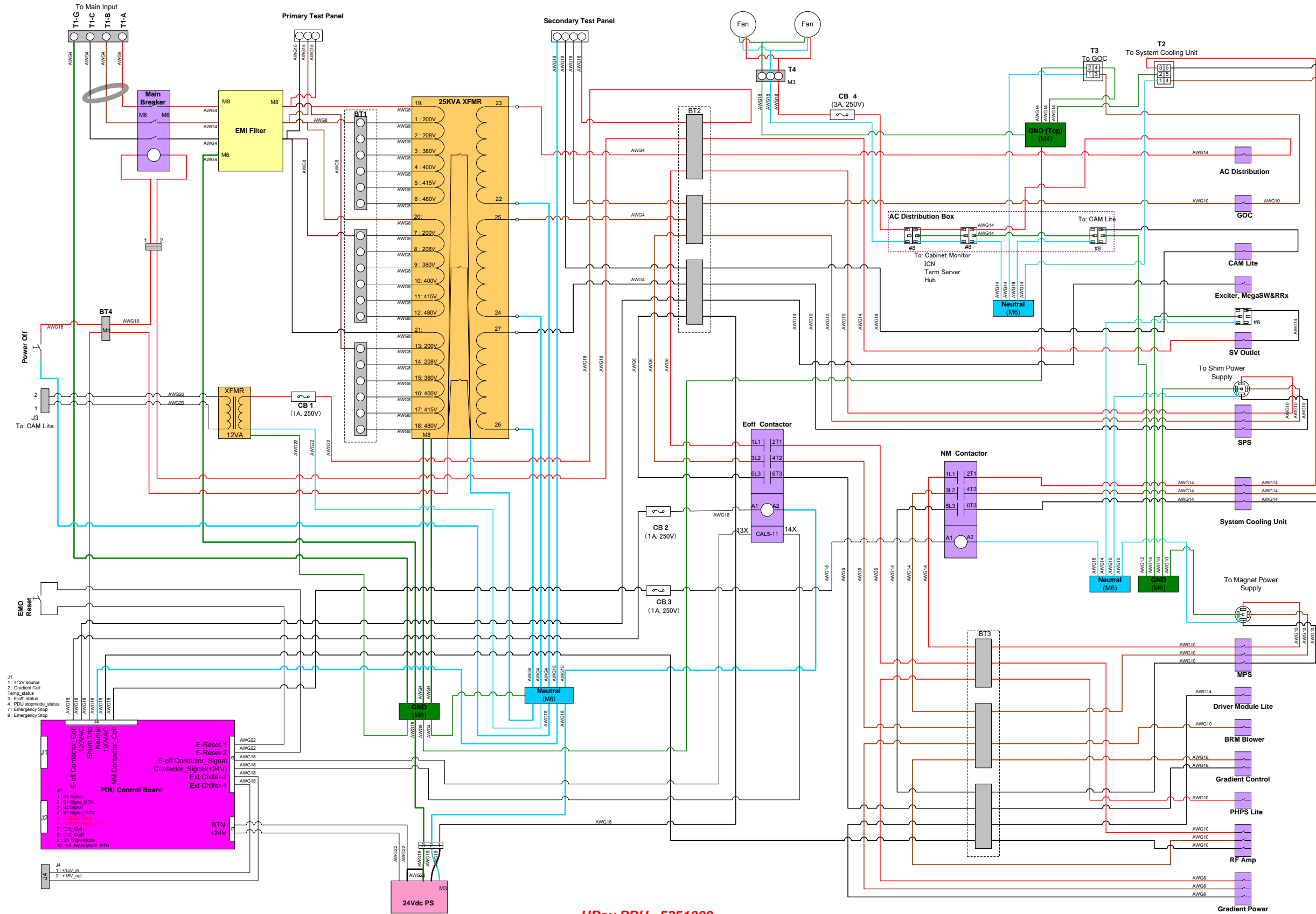

HDsv PDU_ 5351000

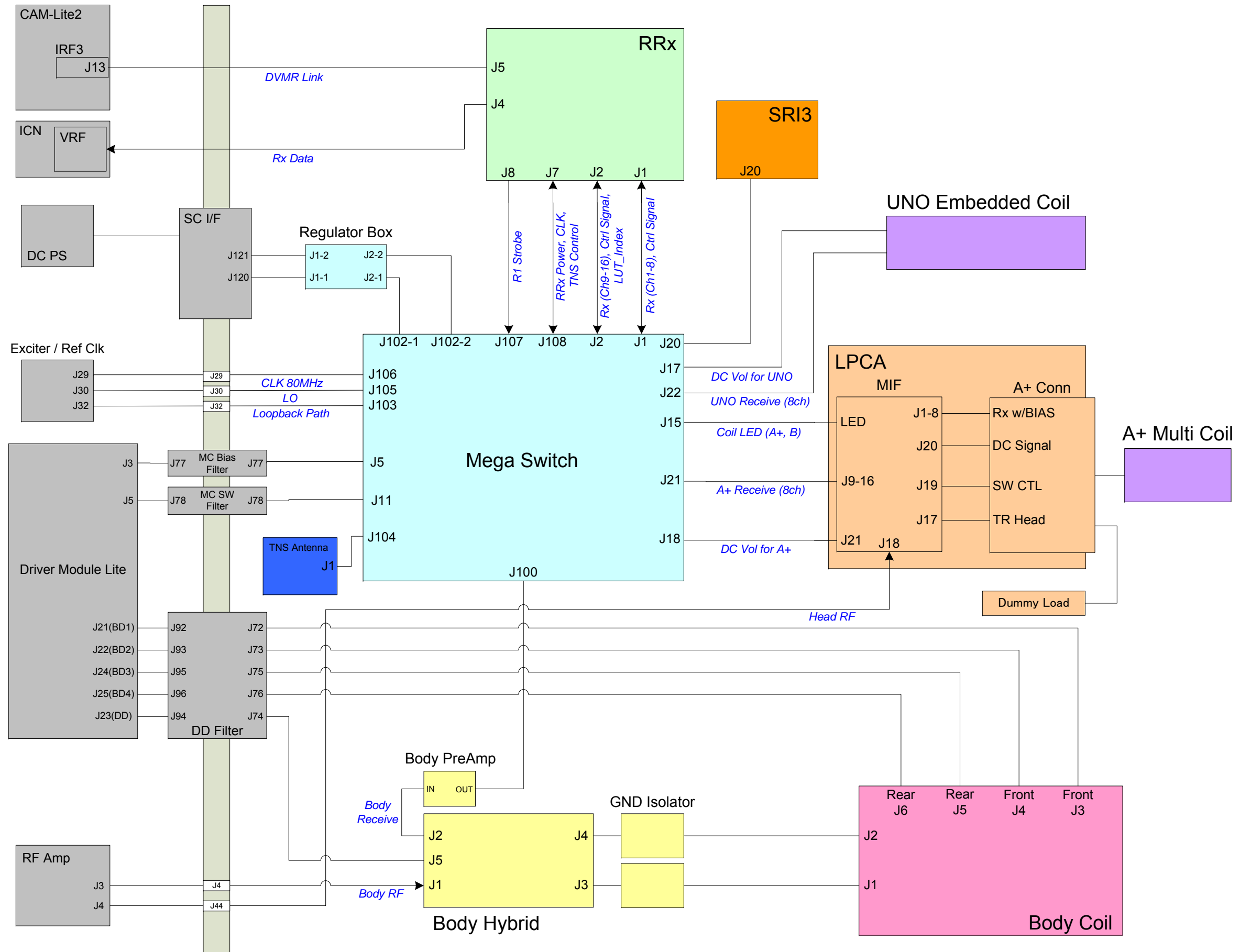

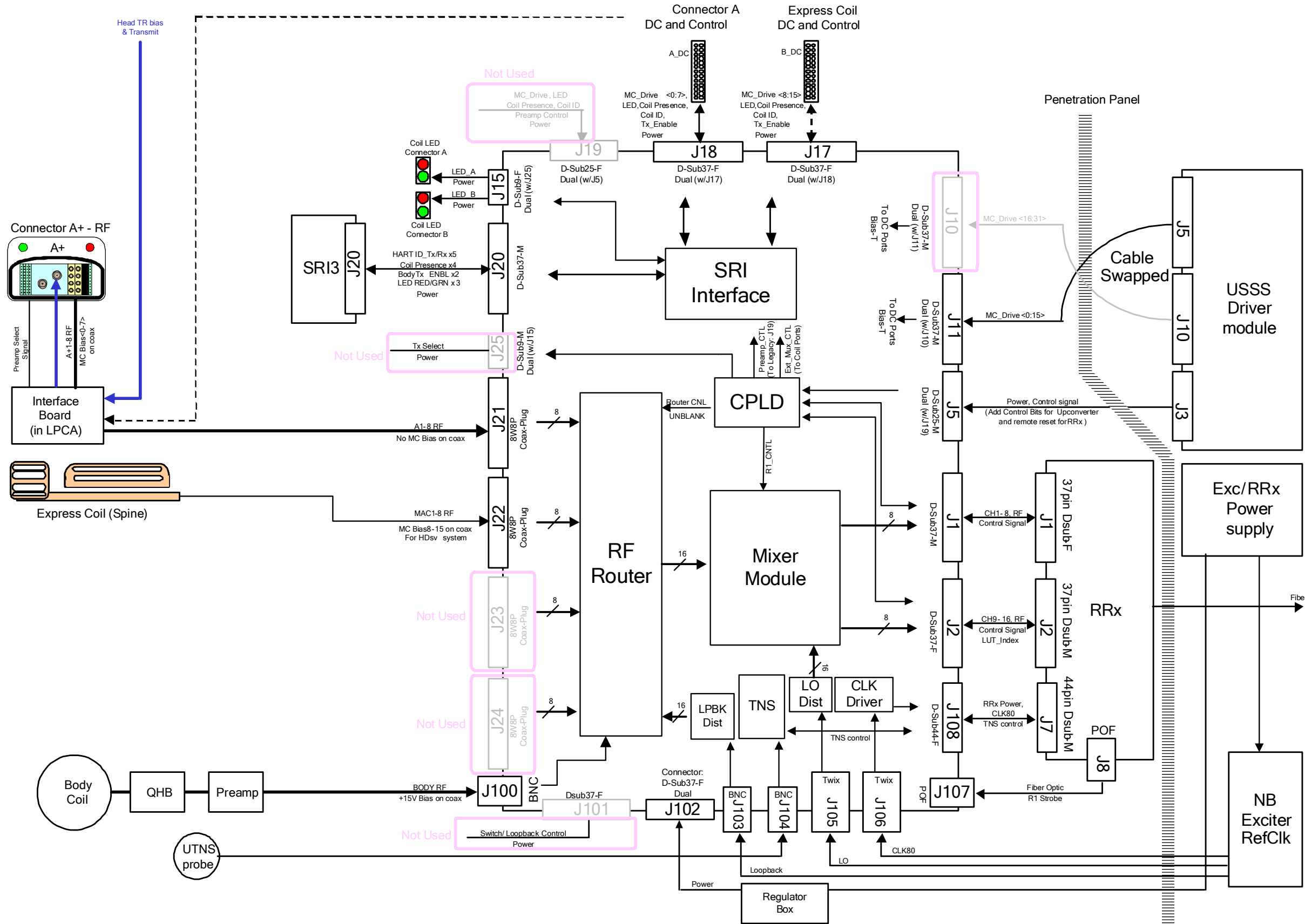

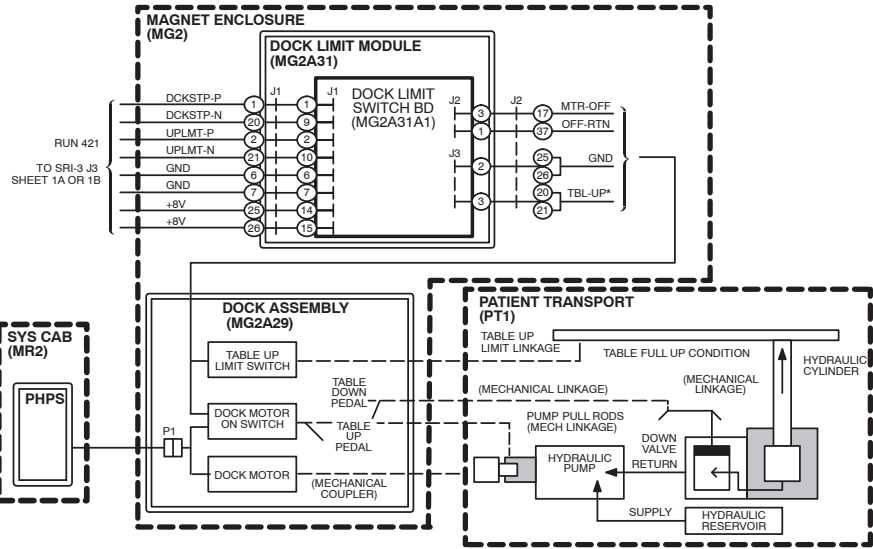
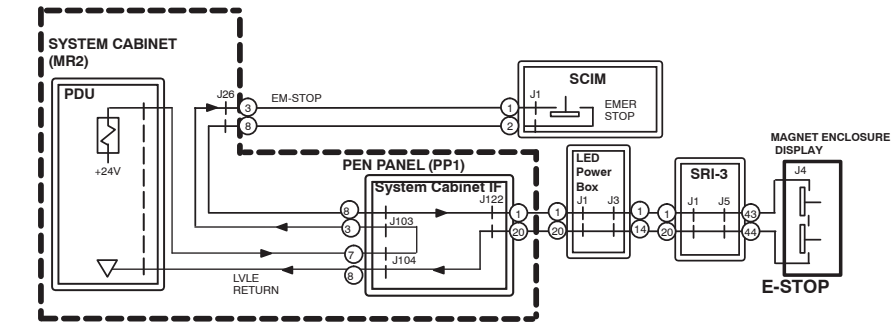

NOTES:

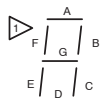

Refer to the following functional block diagrams for additional information. :

1) MGD/RF

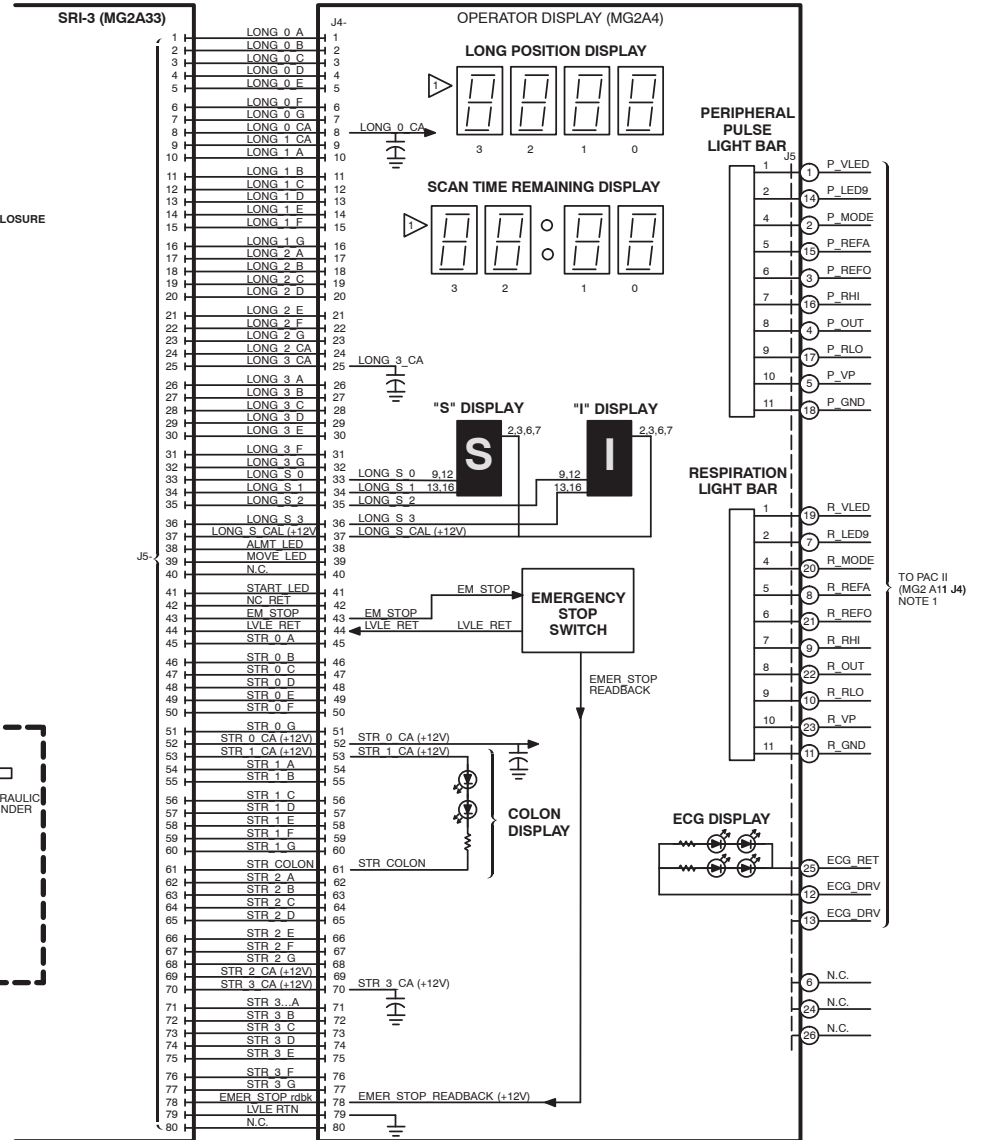

NOTE:

Additional Signal/Cabling detail can be found under Interconnects on the Service Methods CDROM.

Refer to the following functional block diagrams for additional information.

1) MGD/RF

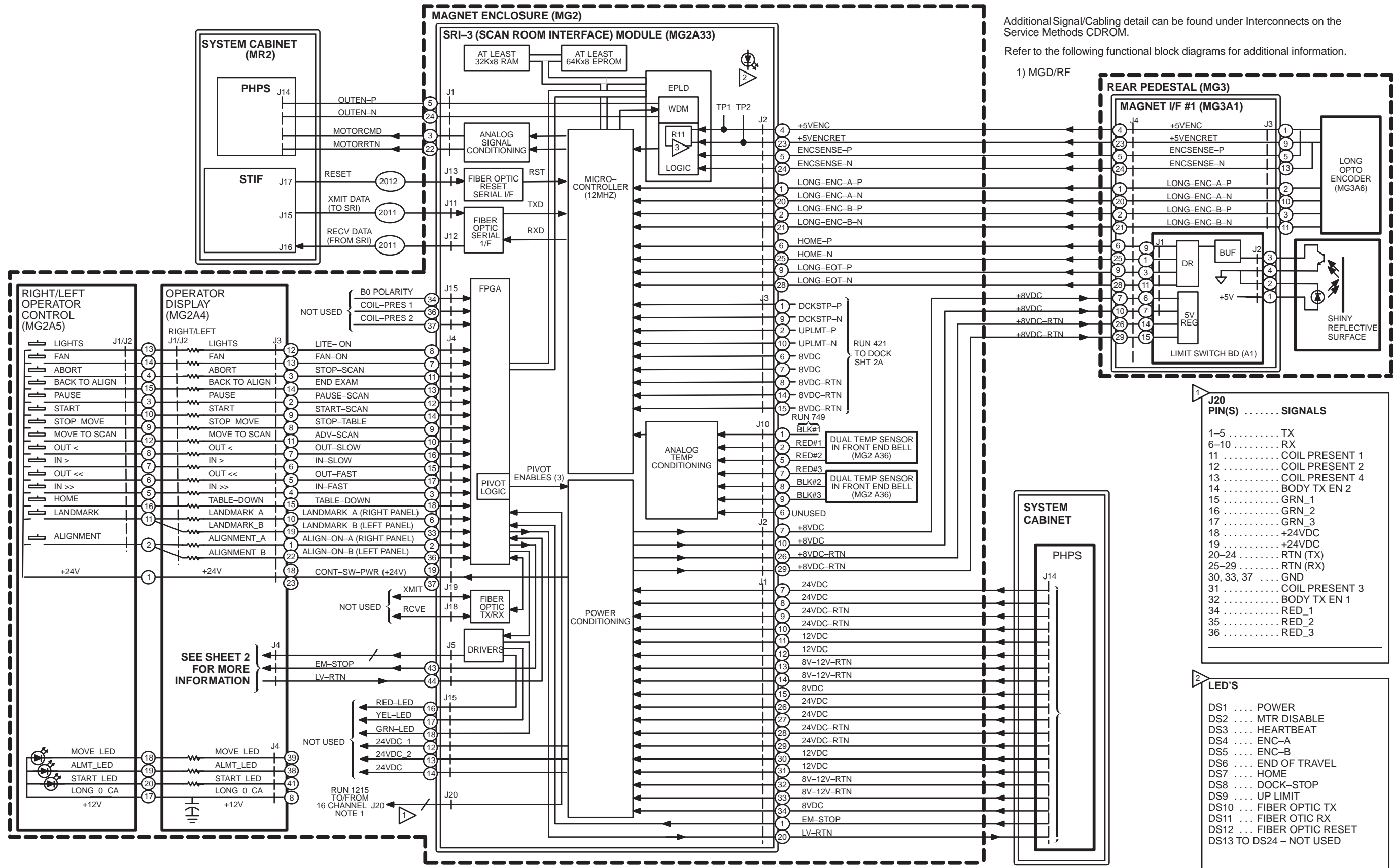

J20 PIN(S) SIGNALS

1-5	TX
6-10	RX
11	COIL PRESENT 1
12	COIL PRESENT 2
13	COIL PRESENT 4
14	BODY TX EN 2
15	GRN_1
16	GRN_2
17	GRN_3
18	+24VDC
19	+24VDC
20-24	RTN (TX)
25-29	RTN (RX)
30, 33, 37	GND
31	COIL PRESENT 3
32	BODY TX EN 1
34	RED_1
35	RED_2
36	RED_3

LED'S

DS1	POWER
DS2	MTR DISABLE
DS3	HEARTBEAT
DS4	ENC-A
DS5	ENC-B
DS6	END OF TRAVEL
DS7	HOME
DS8	DOCK-STOP
DS9	UP LIMIT
DS10	FIBER OPTIC TX
DS11	FIBER OTIC RX
DS12	FIBER OPTIC RESET
DS13 TO DS24	NOT USED

DO NOT ADJUST R11

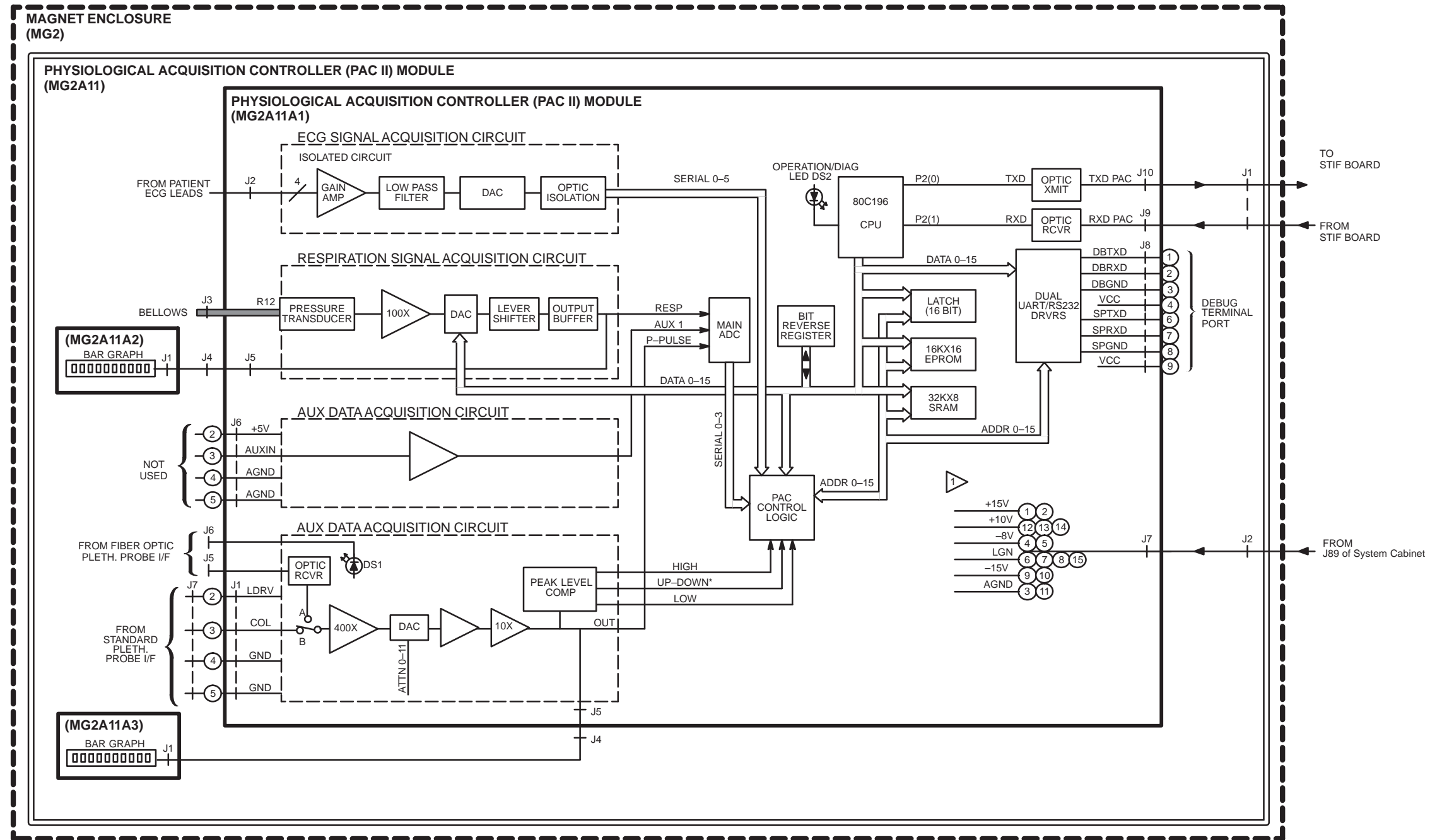

NOTES:
 1 MULTIPLE WIRES/PINS WITH SAME SIGNAL ARE NOT SHOWN

REFER TO THE FOLLOWING FUNCTIONAL BLOCK DIAGRAM FOR ADDITIONAL INFORMATION:

NOTE:
 1) PATIENT HANDLING

This page left intentionally blank.

©2010, General Electric Company.
GE Medical Systems, a General Electric Company, going to market as GE Healthcare.

[www. gehealthcare.com](http://www.gehealthcare.com)

