

# TABLE OF CONTENTS

|   |   |
|---|---|
| TABLE OF CONTENTS .....   | 1 |
| 1- INTRODUCTION .....   | 2 |
| 2- B <sub>0</sub> EDDY CURRENTS: ZEROth-ORDER EDDY CURRENT COMPENSATION ..... | 2 |
| 3- B <sub>0</sub> HARDWARE CHANGES .....                                      | 4 |
| 4- LINEAR EDDY CURRENTS: FIRST-ORDER EDDY CURRENT COMPENSATION .....          | 4 |
| 5- LINEAR EDDY CURRENT HARDWARE CHANGES .....                                 | 6 |
| REVISION HISTORY .....  | 7 |

**1- INTRODUCTION**

Eddy currents degrade image quality. The faster the scan, the more important eddy currents become. Eddy currents must be measured at shorter time intervals than before, due to the faster capability of the Signa Horizon product line. Eddy currents come in three categories: linear long time constant eddy currents, linear short time constant eddy currents, and B<sub>0</sub> eddy currents (FRESBECC, Frequency Shift B<sub>0</sub> Eddy Current Compensation) (see Table 1-1 for all three). There are different implementations for each of the different types of eddy currents.

TABLE 1-1  
EDDY CURRENTS - LINEAR ECC

|  | Analog  | Analog/Digital   | Digital  |
|--|---|--|--|
| <b>Parameter</b>                       | <ul style="list-style-type: none"> <li>• Long time constants</li> </ul>   | <ul style="list-style-type: none"> <li>• Long time constants</li> <li>• Short time constants</li> </ul>  | <ul style="list-style-type: none"> <li>• Long time constants</li> </ul>      |
| <b>Where ECC Occurs</b>                | Done with Tuning (Grafidy) Board on 8607 Master Gradient Amplifier  | Done of GRAM with Digital Turning Board or on GTP for SGU  | Done of IPG-WARP   |
| <b>How to Perform Grafidy</b>          | VI and VA adjusted by potentiometers on the Grafidy Board   | Digital potentiometers on the Digital Tuning Board controlled by software<br><br>High Pass filters on the GIP for SGD that are controlled by software            | VI and VA adjusted by software on IPG-WARP                                   |
| <b>Hardware &amp; Systems Affected</b> | <ul style="list-style-type: none"> <li>• Signa Advantage Release 5.5 with 8607s</li> <li>• All Signa Advantage Release 5.4 Systems</li> </ul> | <ul style="list-style-type: none"> <li>• Signa Horizon HI &amp; Echo Speed (8645s &amp; GRAM</li> <li>• Signa Horizon Hi &amp; Echo with SGD hardware</li> </ul> | <ul style="list-style-type: none"> <li>• Signa Horizon HI (8645s)</li> </ul> |

**2- B<sub>0</sub> EDDY CURRENTS: ZEROth-ORDER EDDY CURRENT COMPENSATION**

Gradient pulses induce eddy currents. Some of these eddy currents cause time-varying magnet field errors with zeroth-order, or B<sub>0</sub>, geometry. Zeroth-order eddy current compensation, also called *B<sub>0</sub> eddy current compensation*, prevents image quality degradations caused by eddy currents. In prior systems, the mechanical alignment of the inner gradient coil with respect to the outer gradient coil was adjusted to minimize B<sub>0</sub> eddy currents. At this time, compensation is done as shown in Illustration L4556A.

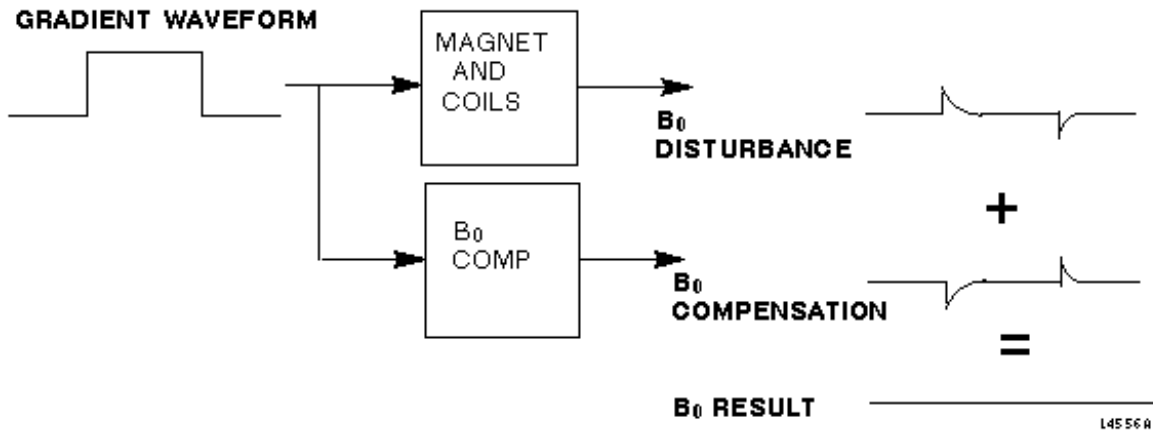

**B<sub>0</sub> EDDY CURRENT RESPONSE AND COMPENSATION FOR EPOXY-FILLED GRADIENT COIL**  
ILLUSTRATION L4556A

The commanded gradient waveforms are fed into a block which realizes the transfer function from gradients to B<sub>0</sub> field disturbance. The negative of the predicted waveform is used to null the B<sub>0</sub> disturbance. Past experience indicates that the transfer function from a gradient axis to the B<sub>0</sub> disturbance can be adequately approximated as shown in the formula in Illustration L4576A, where *N* is equal to 4. The amplitudes *A<sub>i</sub>* and time constants *T<sub>i</sub>* are determined when the Grafidy procedure is used. A unique set of amplitudes and time constants are needed for each gradient axis. The total B<sub>0</sub> disturbance derived from multiple gradient axes is the sum of the individual B<sub>0</sub> disturbances.

$$h_{axis}(t) = \sum_{i=1}^N A_i e^{-t/T_i}$$

L4576A

ILLUSTRATION L4576A

The B<sub>0</sub> disturbance caused by eddy currents can be canceled by pulsing a special B<sub>0</sub> winding; however, the equivalent effect can be achieved by shifting the transceiver reference frequency to track the disturbance. Since the errors are due to the difference between the magnet frequency and the system reference frequency, the effect is the same as canceling the field disturbance. This method is called *Frequency Shift B<sub>0</sub> Eddy Current Compensation* (FRESBECC). See Illustration L4557A.

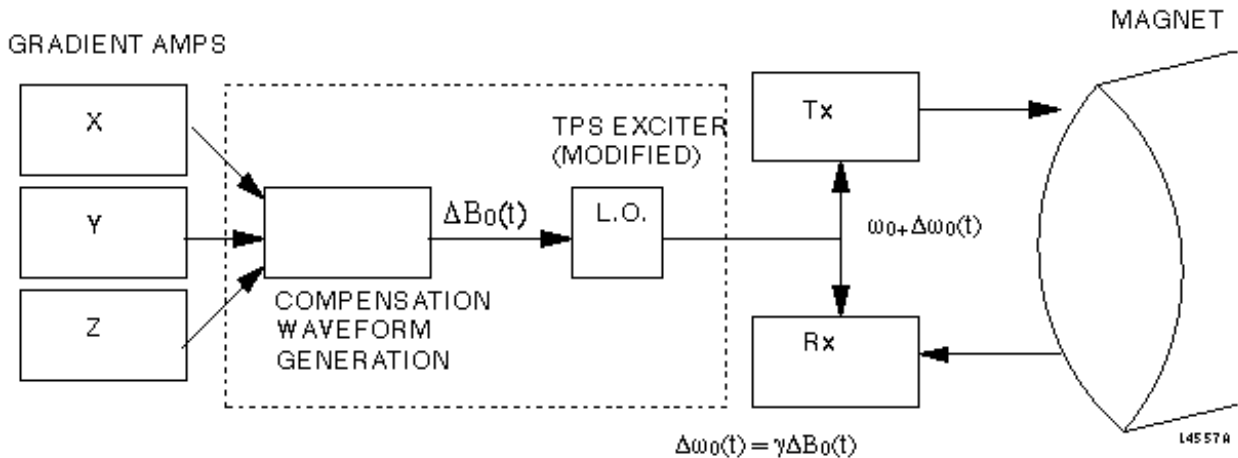

**B<sub>0</sub> EDDY CURRENT BY FREQUENCY SHIFTING**

ILLUSTRATION L4557A

**3- B<sub>0</sub> HARDWARE CHANGES**

IPG hardware and software have been changed so IPG can generate frequency shift wave forms appropriate for zeroth order eddy current compensation. This requires the addition of a bit serial interface from the WARP processor to the backplane. The inputs to the WARP processor function, which generates the Frequency Shift Waveform, are:

The digital gradient commands for physical X, Y, and Z gradients.

A set of calibration values.

The calibration values include four amplitudes and time constants for each axis, plus a scale factor. The output from the IPG is digital frequency shift waveform values in 16-bit C30 bit serial format. The signals are available on the chassis backplane for transfer to the TPS Exciter. The modified IPG is compatible with all 5.5 systems. It also is backward compatible with existing 4.x and 5.x systems.

The TPS Exciter has been changed to accept an additional center frequency offset signal from the chassis backplane.

**4- LINEAR EDDY CURRENTS: FIRST-ORDER EDDY CURRENT COMPENSATION**

Gradient pulses induce eddy currents. Some of these eddy currents cause time varying magnet field errors with the same geometry as the applied pulse. The effect is a distortion of the desired gradient pulse, as shown in Illustration L4558A. First-order eddy current compensation prevents these distortions.

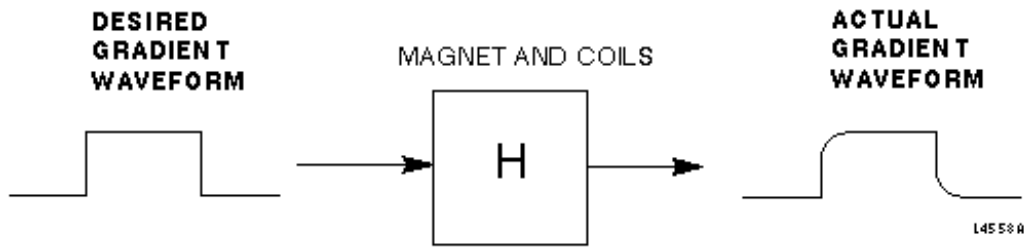

EFFECT OF FIRST-ORDER EDDY CURRENTS

ILLUSTRATION L4558A.

The method used to compensate gradient waveforms for distortion is to apply the inverse of the transfer function, which causes the distortion, prior to playing out the pulse. When the resultant pre-emphasized pulse is played, the final output is the desired gradient pulse, as shown in Illustration L4559A

FIRST-ORDER EDDY CURRENT COMPENSATION

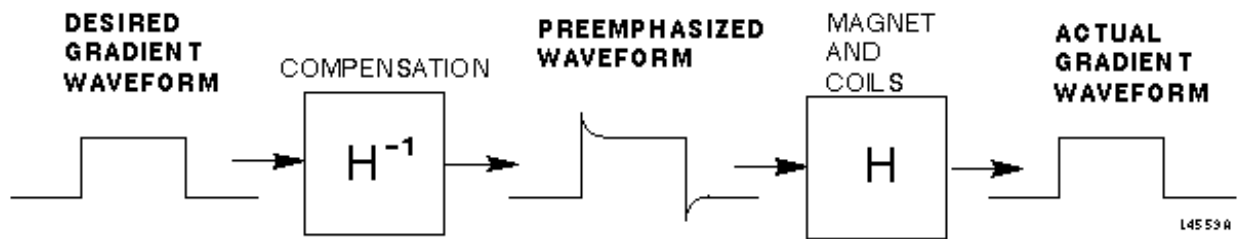

ILLUSTRATION L4559A

Past experience indicates that the transfer function from gradient command input to actual gradient output axis can be adequately approximated as the formula in Illustration L4576B shows, where  $N$  is equal to 4. The amplitudes  $A_i$  and time constants  $T_i$  are determined when the Grafidy procedure is used. A unique set of amplitudes and time constants are needed for each gradient axis.

$$h_{axis}(t) = 1 - \sum_{i=1}^N A_i e^{-t/T_i}$$

L4576 B

## ILLUSTRATION L4576B

In previous products, pre-emphasis was applied by means of analog circuitry on each gradient amplifier (the Grafidy boards). Currently, pre-emphasis is applied either by using similar circuitry on the Gradient Ramp Accelerator Module (GRAM) Tuning Board in system configurations using GRAMs, or by using digital pre-emphasis in the systems cabinet in system configurations with 8645 gradient amplifiers, and without GRAMs. See Table 1-1 for the type of linear eddy current compensation for each configuration.

**5- LINEAR EDDY CURRENT HARDWARE CHANGES**

IPG hardware and software have been changed so that IPG can add pre-emphasis to the generated physical gradient waveforms before they are sent to the gradient amplifiers. The inputs to the WARP processor function, which generates the pre-emphasis, are:

The digital gradient commands for physical X, Y and Z gradients

A set of calibration values

The calibration values include four amplitudes and time constants for each axis. The amplitudes are expressed as a percentage of the desired gradient command. The time constants are in milliseconds. The output from IPG is digital gradient command waveforms with pre-emphasis added, if required for the present system configuration.

## REVISION HISTORY

| REV | DATE         | AUTHOR          | PRIMARY REASONS FOR CHANGE               |
|-----|--------------|-----------------|--|
| 0   | Jun 27, 1998 | L. Loehrer (RH) | Converted Toolbook to Word 7.0 document. |
| 1   | Sep 10, 1998 | K. L-P          | Removed Description section              |
|     |              |                 |  |
|     |              |                 |  |
|     |              |                 |  |