

TABLE OF CONTENTS

1- OVERVIEW	2
2- INITIAL CONDITIONS	2
3- SETUP	3
3-1 Tools Required	3
3-2 Isocenter-Z Scan Procedure.....	3
4- ISOCENTER-Z IMAGE ANALYSIS	5
5- ISOCENTER REPEATABILITY	8
REVISION HISTORY	9

1- OVERVIEW

Note

Before performing the Electrical Isocenter Calibration for the first time, verify that the proper default value is in the MR Config file:

- **12520** - Oxford, SI-SV except Magnishield magnet, SX, SX2C
- **15250** - Magnishield magnet
- **8981** - Cx and LCC magnet

The electrical isocenter is the point where the x, y, and z gradients are nulled. It is very important that this point be accurately located in order to pass the image quality tests.

The procedure uses the DQA-III phantom and the Daily Quality tool for analyzing the data. The Daily Quality tool analyzes the new DQA-III image, and determines the optimal z direction offset that is needed to center the landmark at the z isocenter. The tool optionally updates the isoVector-Z value contained in the system configuration file (MRconfig.cfg). If you choose to update the system configuration file, you must reset the TPS.

Note

Only the Z axis is aligned with this procedure. This procedure, however, may be used to check accuracy in any of the three orthogonal axes.

When the configuration file is updated, perform another scan to verify that the calibration is complete.

2- INITIAL CONDITIONS

- Signa software operational
- First axial image is from center plastic part of DQA phantom that contains GE logo.
- Alignment lights have been physically aligned
- Table has been calibrated per “Longitudinal Drive System” calibration procedure

Note

The longitudinal drive calibration must be performed before doing the electrical isocenter calibration. Failure to follow this sequence will prevent the electrical isocenter calibration procedure from working.

Note

This calibration, in order to be successful, must be started from somewhere in the center plastic part of the phantom that contains the GE logo (in upper right), and comb (in upper left). These markers should have been seen in the axial first image and must be visible in the image used to perform this calibration.

3- SETUP

3-1 Tools Required

- DQA-III Phantom, 2131027-2



POISON HAZARD! THE PHANTOM CONTAINS NICKEL, A SUSPECT CARCINOGEN. DO NOT INGEST. DISPOSE OF AS A HAZARDOUS WASTE ACCORDING TO STATE AND FEDERAL REGULATIONS.

3-2 Isocenter-Z Scan Procedure

1. Click on **[New Pt]**, and press **<Enter>**.
ID: **geservice**
Name: **isocenter cal**
Weight (lb.): **111**
2. Place the DQA-III phantom in the head coil. Position with the fill plugs up, and toward the rear of the magnet (see Illustration 3-1).

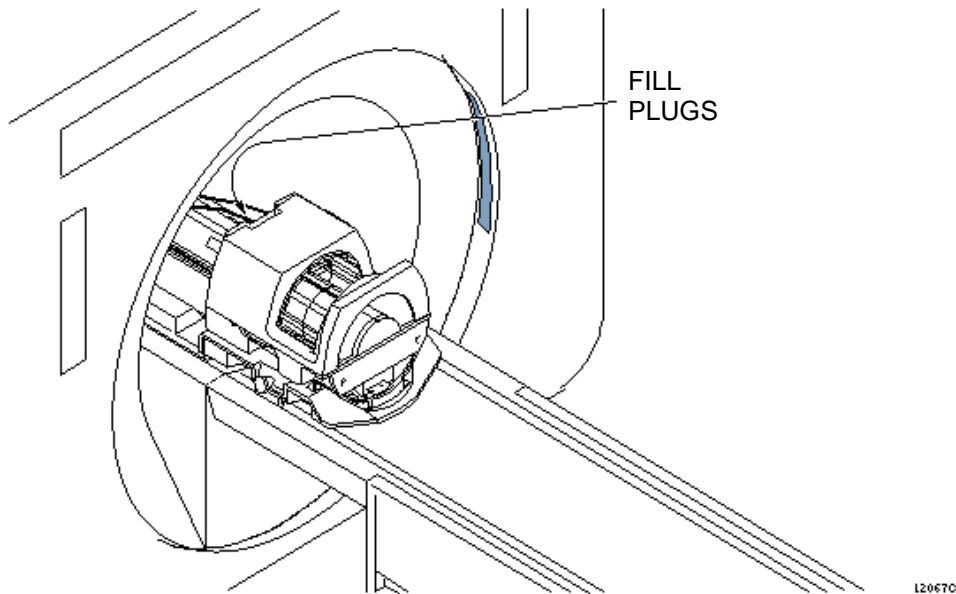

DQA-III PHANTOM POSITIONING
ILLUSTRATION 3-1

3. Landmark in the sagittal and axial planes (DQA-III coronal plane is not at isocenter). See Illustration 3-2 for positioning the phantom in the quad head coil.

Position DQA-III Phantom in the Head Coil.

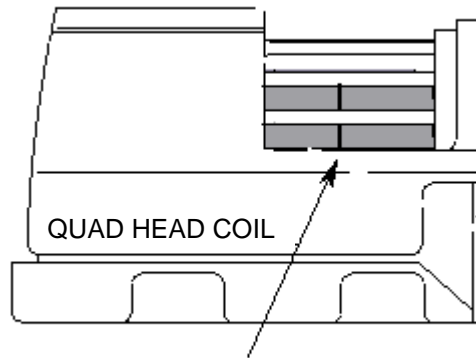

Landmark the DQA-III Phantom on the Landmark Line.

LANDMARKING DQA-III PHANTOM
ILLUSTRATION 3-2

4. At the keypad on the front magnet enclosure, press LANDMARK then MOVE TO SCAN.

Note

Do not rotate or skew the phantom in the head coil. This will cause errors in the analysis of Z isocenter. Landmark errors can also cause errors in the analysis.

5. At the operator workspace, prepare the system to scan using the *Service Protocols* procedure on the service methods CD-ROM, or, for the alternate proprietary procedure, see below.

This alternate proprietary procedure is available for GE use, and to sites with a valid Advanced Service Package Limited License.

- a. Set Patient Protocols to **Service**.
 - b. In the Protocol field, type **o.22.1** (o=Other, 1=series number).
 - c. [**Save Series**], then [**Prepare to Scan**].
6. Select [**Scan**] (system auto prescans first).
 7. Check the geometry of the axial image. Ensure that images are not rotated nor skewed. If they are, reposition the phantom and rescan.

4- ISOCENTER-Z IMAGE ANALYSIS

Note

The Daily Quality tool analyzes the DQA image to determine if the image is skewed in the x direction (x-y planes). Analysis performed on an image with a few degrees of skew will give an accurate isocenter location. If the image is skewed more than a few degrees, it will still be analyzed, but the adjust values for isoVector-Z may be inaccurate. In this case, the phantom should be repositioned and another scan performed.

1. Select **[Cal/Checks]**, from the MR Tools menu. Click **[DQA Calibration]**, and, then click **[Start]**.

For 9.x, 10.x: To start the DQA Calibration tool from the Service Browser, follow the instructions on Illustration 4-1, below:

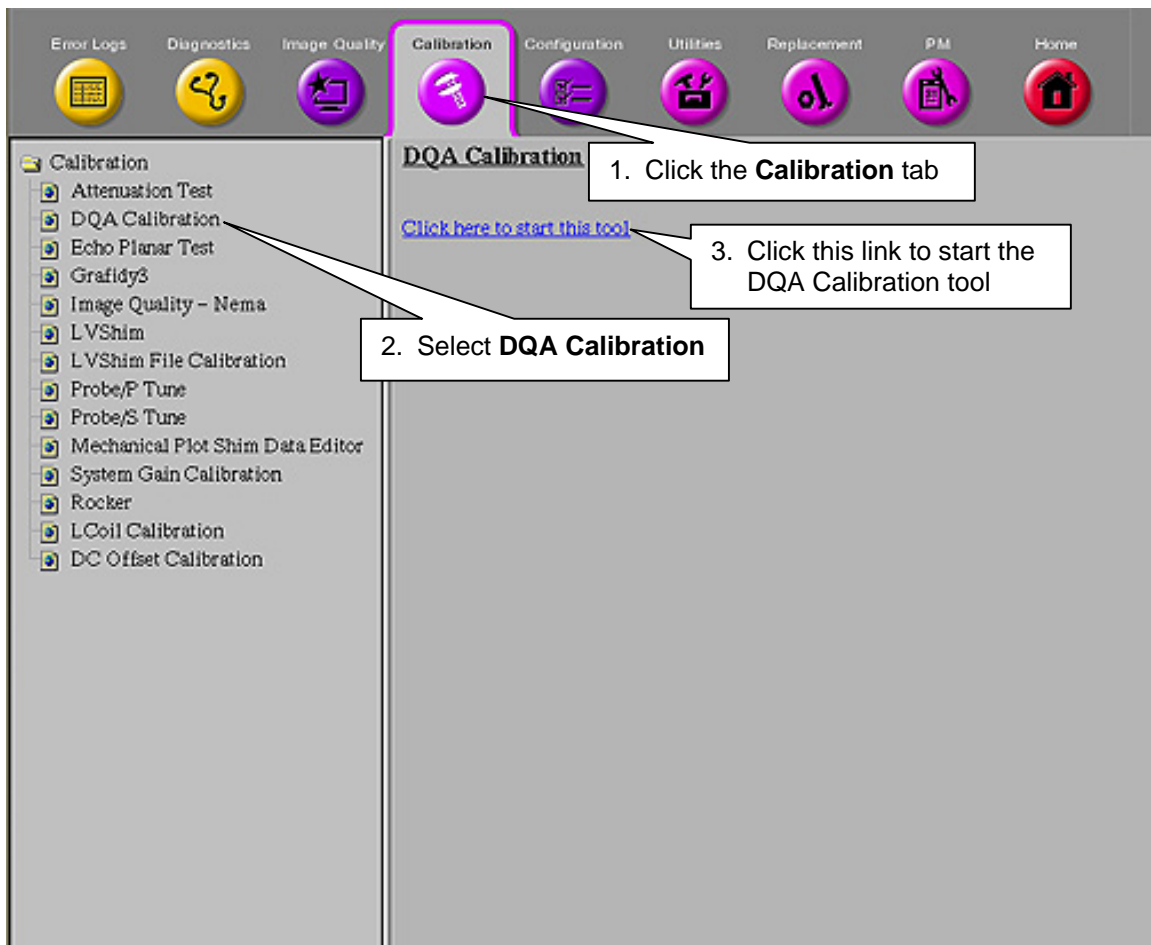

STARTING THE DQA CALIBRATION TOOL FROM THE SERVICE BROWSER
ILLUSTRATION 4-1

2. Continue as shown in Table 4-1.

TABLE 4-1
USING THE DQA CALIBRATION TOOL

OUTPUT/PROMPTS	INPUTS/COMMENTS
<pre> ***** ** Welcome to Automated DQA calibration tool ** ***** !! Please perform [Phantom Position] test scan !! Press Return when <Proper Phantom Position> is obtained Press Return when the desired scan(s) is completed [Y]: Accessing information from last run number... Last Exam is: ===== Exam number: 50022 Series number: 1 Series Description: dqa isoz cal Image number: 1 ===== Accept the Default: (Y,N) [Y] : If n was entered for "Accept the Default:", the following is displayed: Please enter image key manually. Enter Exam Number [50000] : Enter Series Number [1] : Enter image Number [1] : Accessing image, please wait</pre>	<p>Look at the DQA-III phantom image on the image monitor. Be sure it is not skewed more than a few degrees. When the phantom is properly positioned, press <ENTER>.</p> <p><ENTER></p> <p>If the correct image data set is displayed, type y <ENTER>. If not, type n <ENTER>.</p> <p>Enter correct Exam number.</p> <p>Enter correct Series number.</p>

OUTPUT/PROMPTS	INPUTS/COMMENTS
<p><i>If the software does not recognize the "Exam Description", the following is displayed:</i></p> <pre> !!! Unknown Exam Description !!! Please enter test mode manually. ===== == dqa iso z cal analysis in progress == ===== <i>If the phantom is skewed too much, the following is displayed:</i> Attention: specified text position is out of viewport bounds <----- <i>If the scan prescription is incorrect for Isocenter Calibration, the following is displayed:</i> Wrong imaging parameters for Isocenter Calibration <i>If Isocenter Calibration is OK, the following appears:</i> ***** Calibration results ***** < IsoCenter calibrated, no adjustment required.> ***** <i>If Isocenter Calibration needs adjustment, the following appears:</i> ***** Calibration results ***** IsoVectorZ adjustment required ----- 7 (.1mm) ----- <Old IsoVectorZ = 12510> - <New IsoVectorZ =12517> Update IsoVectorZ in MRconfig.cfg (Y,N) : ***** Would you like to perform another calibration (Y,N) [Y] : ***** *Thank you for using Automated DQA calibration Tool * ***** DQA_CAL Exiting! Press [ENTER] to quit --></pre>	<p>Enter correct Image number.</p> <p>If this is displayed, verify the phantom is not skewed, then rescan before re-running this tool.</p> <p>Verify the scan prescription is correct and the correct image data set was selected.</p> <p>Type y <ENTER> to update the MRconfig.cfg file.</p> <p>Type y <ENTER> or n</p>

OUTPUT/PROMPTS	INPUTS/COMMENTS
	<p><ENTER>, as appropriate (N if you updated Mrconfig.cfg).</p> <p>Press <ENTER> key.</p>

3. If the IsoVectorZ value is updated in MRconfig.cfg then press Back to Align at the keypad on the front of the Magnet Enclosure and wait for the table to return to Landmark.
4. If the system is operating with 9.0 software or earlier then perform a System Shutdown and reboot the software.
5. If the system is operating with 9.1 software or later then perform a [TPS Reset] to install the new IsoVectorZ value. A reboot should not be necessary.
6. Establish a Landmark on the phantom (No need to return to Home position) and then repeat the steps in **Section 3-2 Isocenter-Z Scan Procedure** and **Section 4- Isocenter-Z Image Analysis** until the scan analysis indicates [No Adjustment Required].

5- ISOCENTER REPEATABILITY

After the isocenter has been successfully located using the Daily Quality tool, the cradle position will be moved (without changing the landmark) and repositioned back to isocenter. Another scan will be executed and analyzed with the Daily Quality Tool. Repeatable isocenter positioning should produce the status "No adjustment required." If not, perform the Longitudinal Drive System calibration procedure.

1. After the scan analysis indicates "No adjustment required", press FAST OUT to move the phantom/head coil out to somewhere near the alignment light landmark position. Then use MOVE TO SCAN to return the phantom to isocenter.
2. At the operator workspace, click on **[Scan]** (system auto prescans first).
3. After the scan is complete, proceed to Section 4, *Isocenter-Z Image Analysis*. Repeatable isocenter positioning should produce the status "No adjustment required." If not, perform the Longitudinal Drive System calibration procedure, then re-run the Electrical Isocenter calibration procedure.

REVISION HISTORY

REV	DATE	AUTHOR	PRIMARY REASONS FOR CHANGE
0	May 11, 1998	M. Keber	Initial version converted from Toolbook to Microsoft Word.
1	June 15, 1998	Fiore, Keber	Updates based on Engineering Bay validation.
2	Oct 15, 1998	M. Keber	Removed obsolete Release 8.1 information; added LCC default isocenter value.
3	February 11, 1999	K. Keshena	Updates based on Engineering Bay validation to the 1- Overview, 3-2 Isocenter-Z Scan Procedure, and 4- Isocenter-Z Image Analysis sections.
4	July 7, 1999	G. Boerner	Minor edits based on 8.3 Tools Validation
5	Nov 16, 1999	M. Keber	UPDATED TO DO [NEW PT] BEFORE LANDMARK, ALIGNED "INPUT/COMMENTS" TEXT IN ANALYSIS TABLES, CLARIFIED SECTION 5 STEPS PER BAY VALIDATION.
6	Aug 16, 2000	M. Jones	Sec 4-, step 1: Changed "[Daily Quality]" to "[DQA Calibration]"
7	Oct 19, 2000	M. Jones	In first note in section 1-, changed "system configuration file" to "MR Config" file.
8	Feb. 1, 2003	C. MacDonald	Minor edits per Don Thomé
9	Feb 25, 2004	D. Thome	Added note to Section 2 to stipulate location of slice. Updated steps 3 – 6 in Section 4 to support [TPS Reset] IsoVectorZ value install for 9.1 software.