

TABLE OF CONTENTS

1- HEAD AND BODY SPIKE NOISE	2
1-1 Overview	2
1-2 Required Tools	3
1-3 Hardware Preparation for Spike Noise Data Collection	3
1-4 Spike Noise Scan Preparation.....	5
1-5 A/D Sample Noise Data Collection and Analysis.....	6
1-6 Image Data Collection/Analysis	9
2- MULTICOIL SPIKE NOISE	12
2-1 Overview	12
2-2 Required Tools	12
2-3 Hardware Preparation for Spike Noise Data Collection	13
2-4 Spike Noise Scan Preparation.....	13
2-5 A/D Sample Noise Data Collection and Analysis.....	15
2-6 Image Data Collection and Analysis.....	17
REVISION HISTORY	19

1- HEAD AND BODY SPIKE NOISE

1-1 Overview

This test detects small intermittent spike noise sources that may be present in either the RF-shielded room and/or the TPS.

Note

The Head and Body Spike Noise procedure is to be performed on all systems. If the system has the multicoil option installed, also perform section 2- Multicoil Spike Noise.

Short time duration noise spikes generate broadband frequency interference pattern (i.e., corduroy or tweed-like patterns, also horizontal, vertical, or diagonal stripes) artifacts in MR images. Past experience has shown spike noise to be attributed to loose connectors, intermittent ground loops, faulty electronic components in coil assemblies, and corruption of digital data in digital storage or processing areas.

Spike noise greater than 2 mV above the random noise peaks measured at the receiver A/D input can cause image artifacts. A system entirely absent of spike noise is achievable and is the norm. The test consists of the following:

- The head coil is placed in the bore without a phantom.
- A scan is set up, prescan is started and paused to set the TPS / ISE in the receive mode. The receive noise is then observed at the Receiver A/D with a storage scope. This configuration checks for external noise. Then the patient comfort fan is turned on, and the receive noise is again observed, to check for noise originating from the patient fan. Then the fan is turned off.
- Prescan is restarted and the receive noise is again observed at the Receiver A/D with a storage scope. This configuration checks for noise caused by vibration.
- This sequence is repeated seven more times with scan protocols for different axes and frequency directions.
- After the last sequence (Body Axial), the Body SNR or TLT Sphere and Loader are installed, a scan is taken, and the images are reviewed for the presence of hot pixels or artifacts.

1-2 Required Tools

Item	Description	Part Number	Qty
1	100 mHz storage oscilloscope, Tektronix® 468 or equivalent	46-183029P61 or 46-183029P64	1 1
2	TPS RF Service Interface Kit	46-301927G1	1
3	BNC to Palco cable (CERD Spike Noise Test Cable)	2168505	1
4	Body TLT Sphere Phantom	46-265635G6	1
5	Long Body Loader or SPT Body Loader	46-287902G1 2135652-2	1 1



POISON HAZARD! THE PHANTOM CONTAINS NICKEL, A SUSPECT CARCINOGEN. DO NOT INGEST. DISPOSE OF AS A HAZARDOUS WASTE ACCORDING TO STATE AND FEDERAL REGULATIONS.

1-3 Hardware Preparation for Spike Noise Data Collection

1. Remove front panel from Systems Cabinet.
2. Disable the CERD RF Output, by setting the RF Output mode toggle switch (located on the front panel of the CERD), to the RF Out Disable position. See Illustration 1-1.

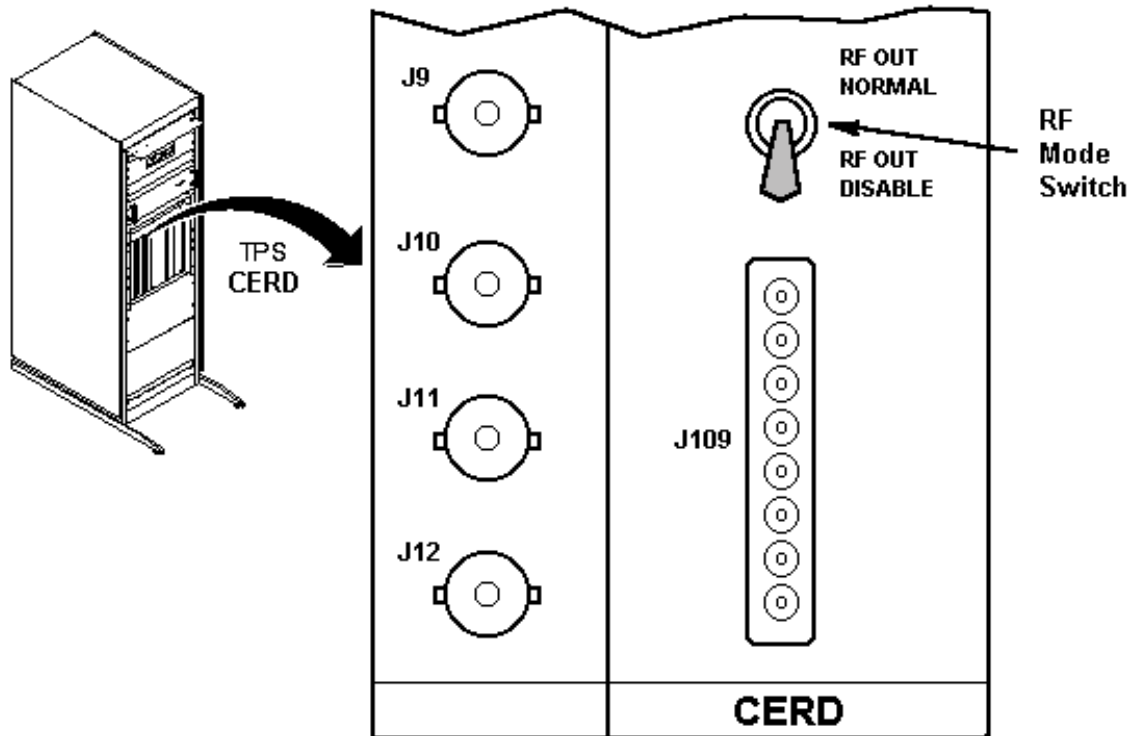

**RF DISABLED FOR SPIKE NOISE SCAN
ILLUSTRATION 1-1**

3. Connect oscilloscope to the CERD as follows: See Illustration 1-2.

Note

Use the systems cabinet service outlet for oscilloscope power to prevent any unwanted ground loops that could cause higher floor noise.

- a. Channel 1 to Receiver, A/D Sample #1 (CERD) using test cable 2168505.
- b. Channel 2 to Receiver, DATA IN WINDOW (CERD).
- c. External Trigger to Receiver, RCVR UNBLK (CERD).

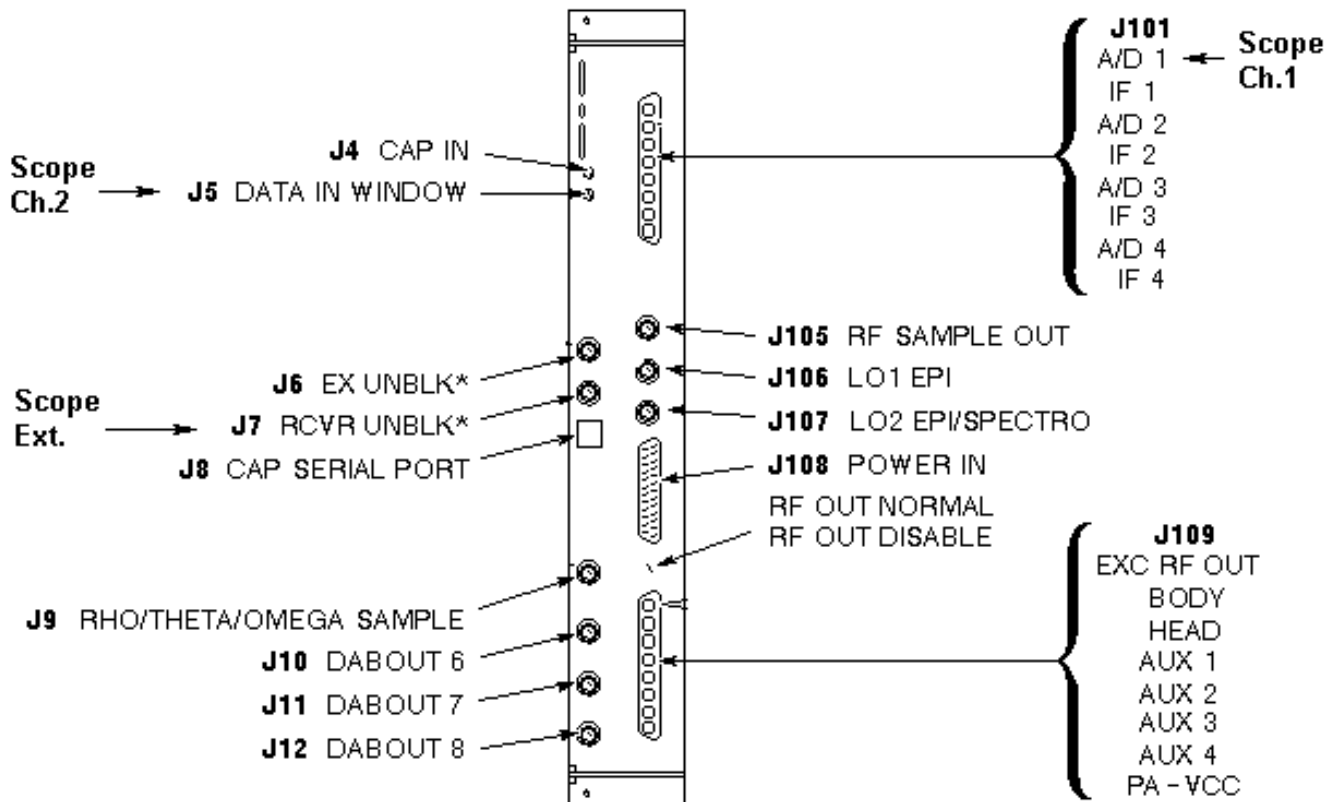

CERD SCOPE HOOKUP
ILLUSTRATION 1-2

4. Set up oscilloscope as follows:

- a. Channel 1 - 5 mV/div for 1.5T system and 10mV/div for 1.0T system, 1 mΩ input.
- b. Channel 2 - 5 V/div, 1 mΩ input.
- c. Time Base - 5 msec/div.
- d. Trigger - auto, external .

1-4 Spike Noise Scan Preparation

1. At the Operator Workspace, select the scan icon in the desktop control panel.
2. If necessary, exit out of any previous exams by selecting **[End Exam]**.
3. Click on **[New Pt]** and enter the following:
 Id: **geservice**
 Name: **spike noise**
 Weight (Lb.): **111**
4. Remove all phantoms from the patient table. This is an empty bore test.
5. Place head coil without phantom on cradle. Landmark on center of head coil. At keypad on front magnet enclosure, press LANDMARK, and MOVE TO SCAN.

*The following three steps are **proprietary** and only available for GE use, and to sites with a valid Advanced Service Package Limited License. The non-proprietary procedure is listed after these steps.*

6. Set Patient Protocols to **Service**.
7. In the Protocol field, Type **o.3.1** (o=Other, 3=protocol number, 1=series number) and **<Enter>**.
 OR
 Click on "Other" and select protocol **3** and series **1** from the menu.
8. Click on **[Accept]** to load the protocol.

Non-proprietary procedure:

At the Operator Workspace, prepare the system for a "Spike Noise - Head, Axial" scan using the scan protocol (**o.3.1**) shown in the "Service Protocols" procedure located on the service methods CD-ROM.

9. Click on **[Save Series]** and then **[Prepare to scan]**.

Note

Use Series 2-8 (o.3.2 - o.3.8) per later procedure steps.

TABLE 1-1 SERIES 1 - 8 SCAN PARAMETERS:

Series 1:[Head] [Axial] I60 S60 [A/P]	Series 5:[Body] [Coronal] P60 A60 [R/L]
Series 2:[Head] [Axial] I60 S60 [R/L]	Series 6:[Body] [Sagittal] R60 L60 [S/I]
Series 3:[Head] [Sagittal] R60 L60 [A/P]	Series 7:[Body] [Axial] I60 S60 [R/L]
Series 4:[Head] [Coronal] P60 A60 [R/L]	Series 8:[Body] [Axial] I60 S60 [A/P]

1-5 A/D Sample Noise Data Collection and Analysis

1. Click on **[Manual Prescan]** and set R1=11, R2=15, TG=0.
2. Select the PAUSE SCAN button on the console keyboard. Press FAN ON button on magnet enclosure to turn off patient comfort fan (fan turns on automatically with scan software).

Note

The TPS is now in the receive mode and any noise can be observed at the Receiver A/D Sample. Scope must be in auto trigger mode.

3. Put scope in continuous memory envelope mode. Adjust the Cursor/No. of Sweeps control on the oscilloscope so that the red LEDs display 9999. This allows all noise to be stored on display. Clear oscilloscope display and ensure trigger is in the auto position.
4. Observe scope display for about two minutes. The noise envelope (channel 1) is typically 2 mV–7 mV p–p for 1.5T systems, and 10 mV p–p for 1.0T systems. **For 1.5T:** Verify that there are no spikes >0.5 N_{env} (where N_{env} is the noise envelope peak to peak value) above noise envelope. **For 1.0T:** Verify that there are no spikes >2.5 mV above N_{env} . See Illustration 1-3.

NOISE SPIKE IS BELOW SPEC
BUT WILL PROBABLY
GET WORSE

CH1 (A/D SAMPLE)
SENSITIVITY =
5 mV/DIV (1.5T)
10 mV/DIV (1.0T)

TIME BASE = 5 ms/DIV
TRIGGER =
AUTO, EXTERNAL

CH2 (DATA IN WINDOW)
SENSITIVITY = 5 V/DIV

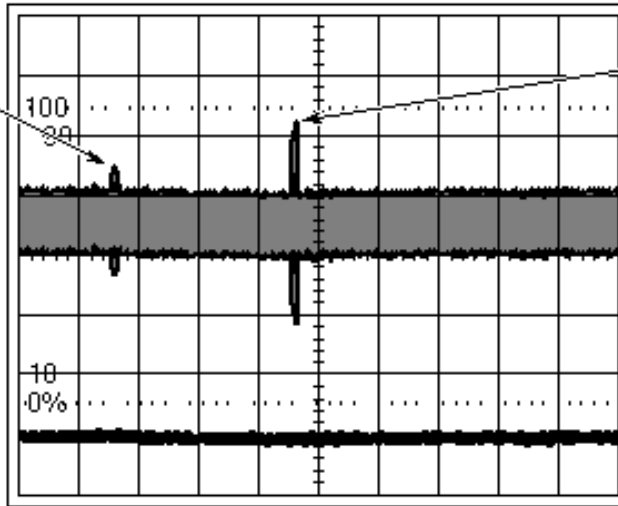

NOISE SPIKE
EXCEED SPECS

SPIKE SPEC:
1.5T = 0.5 Nenv
1.0T = 2.5 mV above Nenv
TYPICAL VALUES FOR
Nenv:
2 mV - 7 mV (1.5T)
10 mV (1.0T)

SPIKE NOISE SCOPE WAVEFORM (PAUSED PRESCAN)
ILLUSTRATION 1-3

Note

A 4 - 6mV 10-mHz clock signal is present at all times on the a/d sample output. This signal should be disregarded as it rides within the noise band.

Note

Ideally, there should be no spikes beyond the envelope. Any spikes present indicate that a connection is loose, or a component is bad (i.e., intermittent connection of power cable to a shield cooler cold head, or copper fingers on exam room door are damaged). Noise spikes that are greater than the spike spec create images with corduroy-like artifacts. Noise spikes that are presently less than the spike spec will probably get worse over time.

Note

If there are no spikes present, and you are in doubt whether the set-up is working, you can simulate an RF leak by opening the exam room door, or by turning room lights on/off if site is RF quiet. Clear the oscilloscope display and observe the new waveform on the display. You should now see noise spikes beyond the waveform envelope. Don't forget to close exam room door when you are finished.

5. Press the FAN ON button on the magnet enclosure to turn on the patient comfort fan. Clear the oscilloscope display and ensure that trigger is in the Auto position. Observe the oscilloscope display for about two minutes. The noise envelope (channel 1) should remain as described in step 4 above.

Note

Ideally, there should be no additional spikes with the fan on. Any additional spikes that are present indicate that RF noise is originating from the fan. It is also possible for the fan to produce so much RF noise that, instead of seeing additional spikes, you would see an increase in the level of the waveform envelope compared to when the fan is off.

6. Clear oscilloscope display and change trigger from Auto to Normal.
7. Press the FAN ON button on the magnet enclosure to turn off the patient comfort fan.
8. Press the START SCAN button on the console keyboard to resume prescan. Click on **[Scan T/R]**.
9. Observe scope display after two minutes. The noise envelope (channel 1) should be approximately 2 mV–7 mV for 1.5T systems, and 10 mV p–p for 1.0T systems. **For 1.5T:** Verify that there are no spikes $>0.5 N_{env}$ (where N_{env} is the noise envelope peak-to-peak value) above the noise envelope in the region of interest (except for TPS / ISE Transition Spike). **For 1.0T:** Verify that there are no spikes >2.5 mV above N_{env} in the region of interest (except for TPS / ISE Transition Spike). See Illustration 1-4.

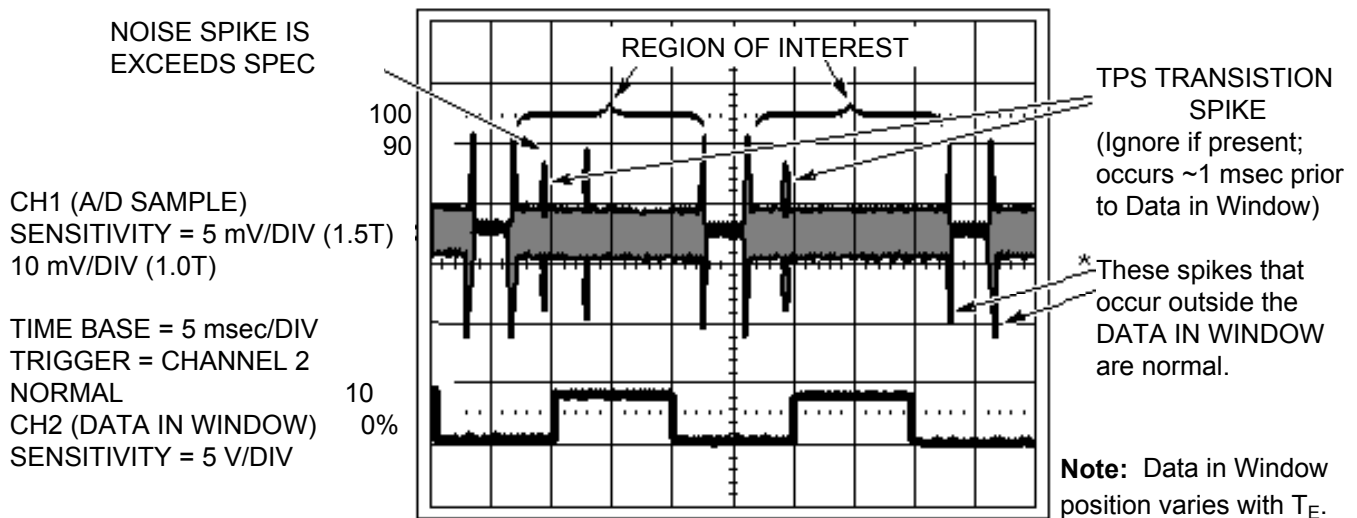

SPIKE NOISE SCOPE WAVEFORM (PRESCANNING)
ILLUSTRATION 1-4

Important! The Region of Interest extends beyond when the observed Data In Window signal is high because the Data In Window position varies with T_E . The TPS / ISE Transition Spike (not always present) occurs when the TPS / ISE transitions from transmit to receive frequency; it occurs ~1 msec prior to the Data In Window. (The TPS / ISE frequency transition point can be confirmed by viewing DDS OUT signal on the Exciter Board.)

Note

If the spike noise appears only during prescan, the problem is more likely to be a loose connector, freely hanging cables near the magnet, poorly soldered components, or coil mounting hardware. Anything that is subject to vibration from gradient activity should be investigated.

10. Click on **[New Series]**. Setup Scan Prescription for series #2 scan per notes and Table 1-1 in Section 1-4, then repeat steps 7 through 9 of Section 1-4.

Repeat this step until all head prescans (series #1 through #4) have been completed.

Equipment damage possibility. Completely remove the Quad Head Coil from the cradle before performing any body scans. Failure to do so may damage the head coil T/R network.

11. Remove head coil from cradle.
12. Click on **[New Series]**. Setup scan prescription for series #5 scan (per notes and Table 1-1 in Section 1-4), then repeat steps 7 through 9 of Section 1-5

Repeat this step until all body prescans (series #5 through #8) have been completed.

Note

If spikes occur in body scans but not in head scans, then Dynamic Disable Switch Boxes and associated connections are suspect.

1-6 Image Data Collection/Analysis

1. Disconnect the oscilloscope from the TPS/ISE chassis and restore all cables to their normal configuration.
2. Reset the CERD RF Output mode switch to the **Normal** position (located on the CERD front panel).
3. Install front cover panel on Systems Cabinet.
- 4a. *Setup using SPT Loader:* Position the SPT body loader and TLT sphere on the table and landmark per Illustration 1-5A.

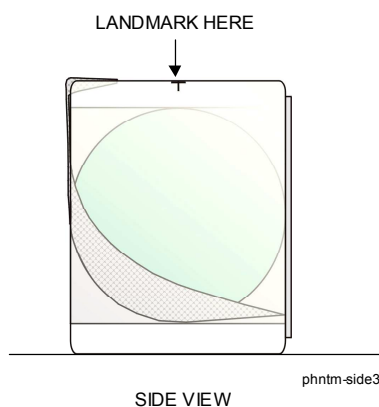

SPT BODY LOADER AND TLT PHANTOM SETUP
ILLUSTRATION 1-5A

4b. *Setup using Long Body Loader.* Position the body TLT sphere in the center of the long body loader and landmark per Illustration 1-5B.

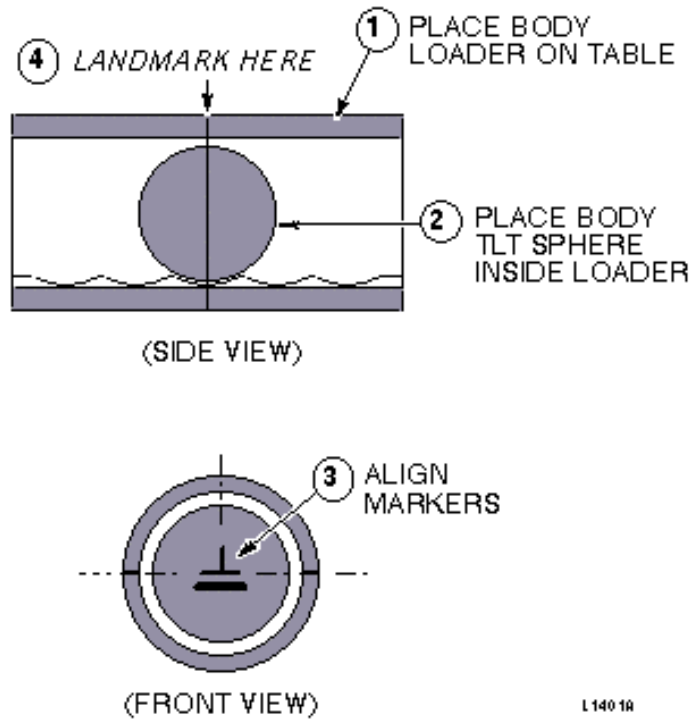

LONG BODY LOADER AND TLT PHANTOM SETUP
ILLUSTRATION 1-5B

5. Click on **[New Series]** and select the last scan prescription from procedure in Section 1-4.
6. At front enclosure, press LANDMARK, then MOVE TO SCAN.
7. Click on **[Save Series]**, then **[Prepare to Scan]**.
8. Click on **[Scan]** (system auto prescans first).

- 9. Display and examine each of the twenty images for tweed-like or stripe-like artifacts. See Illustration 1-6. If artifacts are present, use the procedures described in *EPI White Pixel Troubleshooting Guide* to troubleshoot the system.

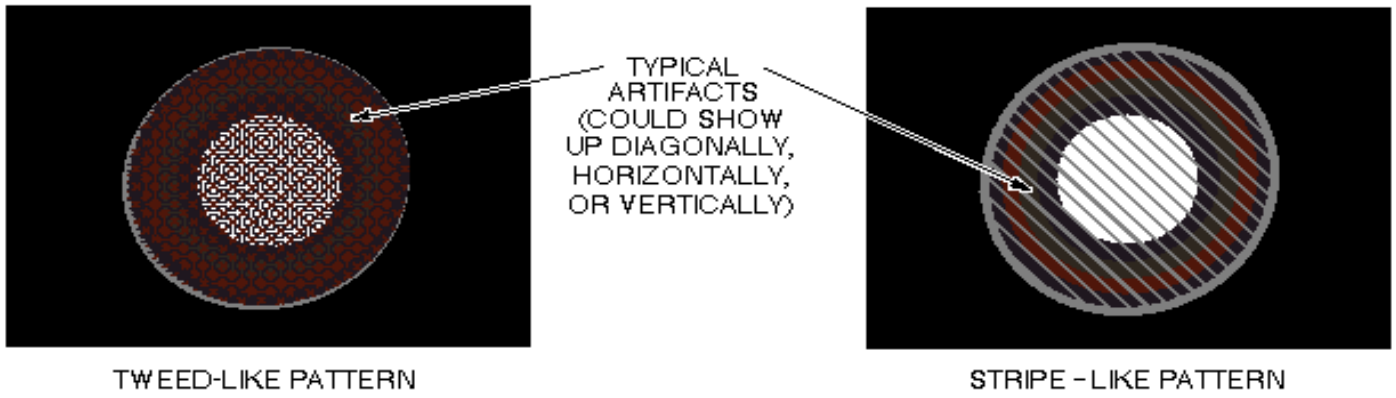

TLT SPHERE WITH TYPICAL ARTIFACTS
ILLUSTRATION 1-6

2- MULTICOIL SPIKE NOISE

Note

This procedure is to be performed on systems with the multicoil option installed. If the CTL array is not available, use the pelvic coil and pelvic coil phantom assembly to perform this procedure.

2-1 Overview

This test is used to detect small intermittent spike noise sources that may be present in the multicoil array and associated hardware. This type of noise usually shows up as corduroy artifacts in the image, or white pixels in the raw data. The sources of this type of noise can be anything from bad PIN diodes to poorly assembled cables. The test consists of the following:

Note

Spike Noise for Body and Head must have been performed by using procedure in section 1- Head and Body Spike Noise, before performing this procedure.

- The multicoil array to be tested is placed in the bore without its positioner and sphere phantoms.
- A scan is set up, prescan is started and paused to set the TPS / ISE in the receive mode. The receive noise is observed at each of the Receiver A/Ds being used with a storage scope. This configuration checks for external noise. Then the patient comfort fan is turned on and the receive noise is again observed, to check for noise originating from the patient fan. Then the fan is turned off.
- Prescan is restarted, and the receive noise is again observed with a storage scope at each of the Receiver A/Ds being used. This configuration checks for noise sourced by vibration.
- The positioner and sphere phantoms for the multicoil to be tested are installed, a scan is taken, and the images are reviewed for the presence of hot pixels or artifacts.

2-2 Required Tools

Item	Description	Part Number	Qty
1.	100 MHz storage oscilloscope, Tektronix® 468 or equivalent	46-183029P61 or P64	1
2.	TPS RF Service Interface Kit	46-301927G1	1
3.	Positioner & Sphere Phantoms for the Multicoil to be tested:		
	CTL Coil Phantom Assembly Pelvic	46-317605G1	1
	Coil Phantom Assembly.....	46-317626G1	1

2-3 Hardware Preparation for Spike Noise Data Collection

1. Remove front panel from Systems Cabinet.
2. Disable the CERD RF Output, by setting the RF Output mode toggle switch (located on the front panel of the CERD), to the RF Out Disable position. See Illustration 1-1.

Note

Use the systems cabinet service outlet for oscilloscope power to prevent any unwanted ground loops that could cause higher floor noise.

3. Connect oscilloscope to the CERD as follows: See Illustration 1-2.
 - a. Channel 1 to Receiver, A/D Sample #1 (CERD) using test cable 2168505.
 - b. Channel 2 to Receiver, DATA IN WINDOW (CERD).
 - c. External Trigger to Receiver, RCVR UNBLK (CERD).
4. Set up oscilloscope as follows:
 - a. Channel 1: 2 mV/div, 1 m Ω input.
 - b. Channel 2: 5 V/div, 1 m Ω input.
 - c. Time Base: 5 msec/div.
 - d. Trigger: auto, external.

2-4 Spike Noise Scan Preparation

Note

The CTL phased array is used as an example in sections 2-4 and 2-5. Other phased arrays can be tested for spike noise, using a similar procedure, by selecting the appropriate coil name in the scan prescription and testing the receiver modules that are used for that array.

Equipment damage possibility. Completely remove the Quad Head Coil from the cradle before performing any body scans. Failure to do so may damage the head coil T/R network.

1. At the Operator Workspace, select the scan icon in the desktop control panel.
2. If necessary, exit out of any previous exams by selecting **[End Exam]**.
3. Click on **[New Pt]** and enter the following:
Id: **geservice**
Name: **multicoil spike**
Weight (Lb.): **111**
4. Remove all phantoms from the patient table.

- Place multicoil array without sphere phantoms on cradle. Connect the multicoil connector to its mating receptacle. Landmark on center of multicoil array. (See Illustration 2-1 for an example using the CTL Array.)

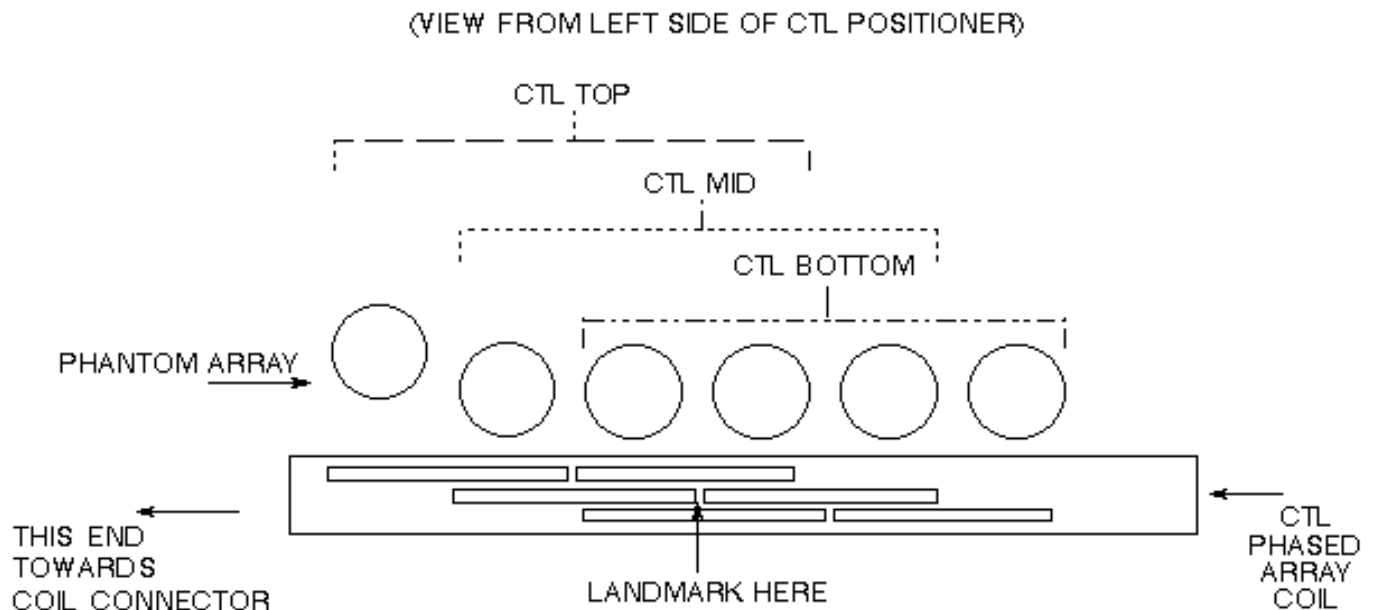

Note: The CTL array contains six coils (only four are used at one time). Three regions are designated (landmarks for each region are marked on the side of the array). The CTLTOP array uses coils 1 through 4 (counting from the head end). CTLMID uses coils 2 through 5. CTLBOT uses coils 3 through 6.

CTL PHANTOM/POSITIONER LANDMARK SETUP
ILLUSTRATION 2-1

- At keypad on magnet front enclosure, press LANDMARK, and MOVE TO SCAN.

*The following three steps are **proprietary** and only available for GE use, and to sites with a valid Advanced Service Package Limited License. The non-proprietary procedure is listed after these steps.*

- Set Patient Protocols to **Service**.
- In the Protocol field, Type **o.14.1** (for top array) or **o.14.2** (for bottom array) and **<Enter>**.
OR
Click on "Other" and select protocol **14** and series **1** (for top array) or **2** (for bottom array) from the menu.
- Click on **[Accept]** to load the protocol.

Non-proprietary procedure:

At the Operator Workspace, prepare the system for a "Multicoil Spike Noise" scan using the scan protocol (**o.14.1** or **2**) shown in the "Service Protocols" procedure located on the service methods CD-ROM.

Note

Use Series 2 per later procedure steps.

10. Click on Coil [...] in Patient Position setup. Click on **[Phased Array]**, select **CTLBOT**, then **[Accept]**. Click on **[Save Series]**, then **[Prepare to scan]**.

2-5 A/D Sample Noise Data Collection and Analysis

1. Click on **[Manual Prescan]** and set R1=11, R2=15, TG=0.
2. Click on **[Scan TR]**, then press the PAUSE SCAN button on the console keyboard. Press FAN ON button on magnet enclosure to turn off patient comfort fan (fan turns on automatically with scan software).

Note

The TPS is now in the receive mode and any noise can be observed at the Receiver A/D Sample. Scope must be in auto trigger mode.

3. Put scope in memory envelope mode, i.e., Continuous Sampling (Cumulative Data). Adjust the Cursor/No. of Sweeps control on the oscilloscope so that the red LEDs display 9999. This allows all noise to be stored on display. Clear oscilloscope display and ensure that trigger is in the Auto position.
4. Observe scope display for about two minutes. The noise envelope (channel 1) is typically 2 mV–7 mV p–p for 1.5T system, and 10 mV p–p for 1.0T systems. **For 1.5T:** Verify that there are no spikes >0.5 N_{ENV} (where N_{ENV} is the noise envelope peak to peak value) above noise envelope. **For 1.0T:** Verify that there are no spikes >2.5 mV above N_{ENV} . See Illustration 1-3.

Note

Ideally, there should be no spikes beyond the envelope. Any spikes present indicate that a connection is loose, or a component is bad (i.e., intermittent connection of power cable to a shield cooler cold head, or copper fingers on exam room door are damaged). Noise spikes that are greater than the spike spec create images with corduroy-like artifacts. Noise spikes that are presently less than the spike spec will probably get worse over time.;

Note

If there are no spikes present, and you are in doubt whether the set-up is working, you can simulate an RF leak by opening the exam room door, or by turning room lights on/off if site is RF quiet. Clear the oscilloscope display and observe the new waveform on the display. You should now see noise spikes beyond the waveform envelope. Don't forget to close exam room door when you are finished.

5. Press the FAN ON button on the magnet enclosure to turn on the patient comfort fan. Clear the oscilloscope display and ensure trigger is in the auto position. Observe the oscilloscope display for about two minutes. The noise envelope (channel 1) should remain as described in Step 4 above.

Note

Ideally, there should be no additional spikes with the fan on. Any additional spikes that are present indicate that RF noise is originating from the fan. It is also possible for the fan to produce so much RF noise that, instead of seeing additional spikes, you would see an increase in the level of the waveform envelope compared to when the fan is off.

6. Press the FAN ON button on the magnet enclosure to turn off the patient comfort fan.
7. Move channel 1 (A/D Sample), channel 2 (DATA IN WINDOW) and external trigger (RCVR UNBLK) to the next J101 connector point: A/D 2.. Clear oscilloscope display. Repeat steps 3 to 7 for the other two connector points, then reconnect oscilloscope back to first receiver connector point.
8. Clear oscilloscope display and change trigger from Auto to Normal.
9. Press the START SCAN button on the console keyboard to resume prescan.
10. Observe scope display after two minutes. The noise envelope (channel 1) should be approximately 2 mV–7 mV for 1.5T systems, and 10 mV p–p for 1.0T systems. **For 1.5T:** Verify that there are no spikes $>0.5 N_{ENV}$ (where N_{ENV} is the noise envelope peak to peak value) above the noise envelope in the region of interest (except for TPS / ISETransition Spike). **For 1.0T:** Verify that there are no spikes >2.5 mV above N_{ENV} in the region of interest (except for TPS / ISETransition Spike). See Illustration 1-4.

Important! The Region of Interest extends beyond when the observed Data In Window signal is high because the Data In Window position varies with TE. The TPS / ISETransition Spike (not always present) occurs when the TPS / ISE transitions from transmit to receive frequency; it occurs ~ 1 msec prior to the Data In Window. (The TPS / ISE frequency transition point can be confirmed by viewing DDS OUT signal on the Exciter Board.)

Note

If the spike noise appears only during prescan, the problem is more likely to be a loose connector, freely hanging cables near the magnet, poorly soldered components, or coil mounting hardware. Anything that is subject to vibration from gradient activity should be investigated.

11. Repeat steps 8 through 10 for the other three receivers being used.
12. Click on **[New Series]**. Setup Scan Prescription for series #2 scan per Notes, above. **[Save Series]**, and **[Prep to Scan]**, then repeat steps 5 through 10, above.

2-6 Image Data Collection and Analysis

1. Disconnect oscilloscope from TPS / ISE chassis.
2. Reset the CERD RF Output mode switch to the **Normal** position (located on the CERD front panel).
3. Install right front cover panel on Systems Cabinet.
4. Position Multicoil Positioner and Sphere Phantoms on multicoil array. See Illustration 2-2.

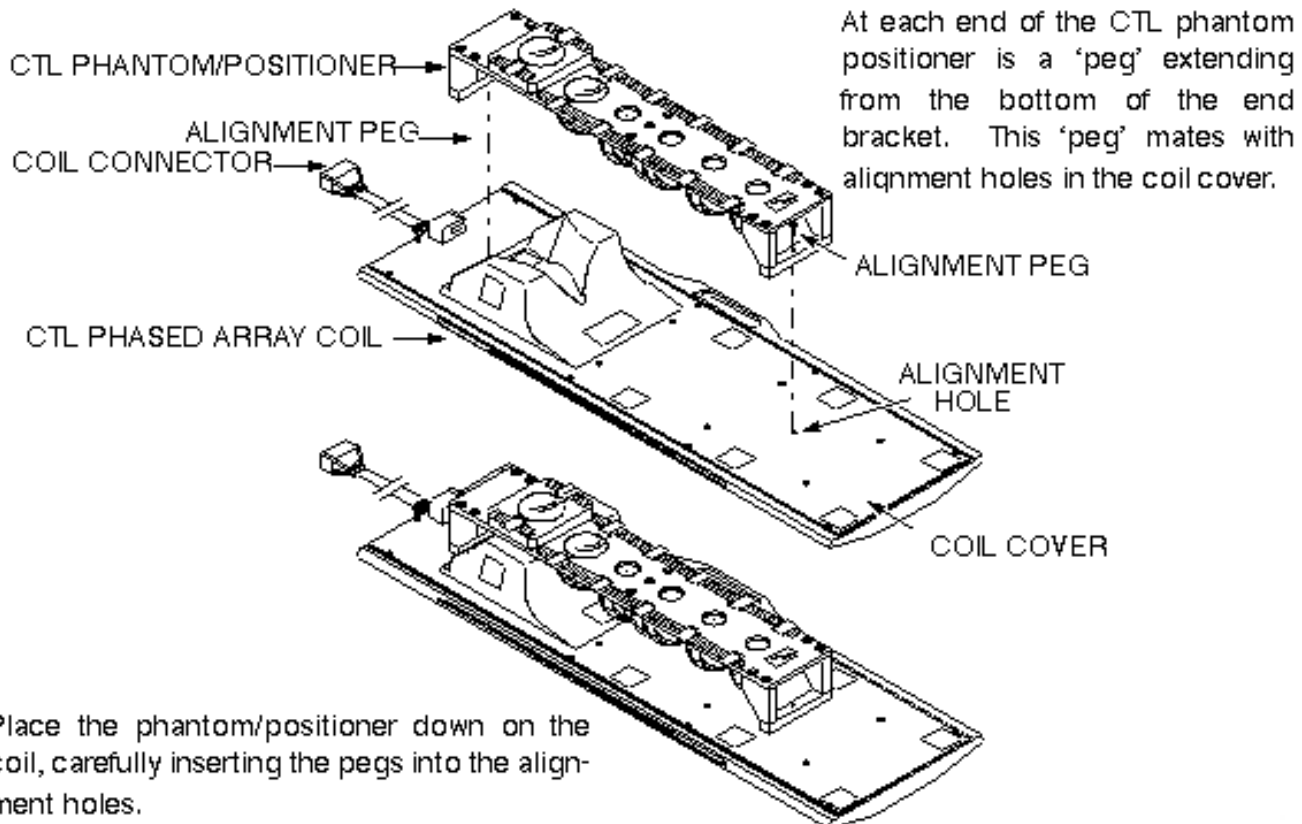

INSTALLING MULTICOIL POSITIONER AND SPHERE PHANTOMS
ILLUSTRATION 2-2

5. See Illustration 2-1 for landmarking phantom. At magnet enclosure, press OUT button, install phantom, then press MOVE TO SCAN.
6. Setup scan prescription for series #2 scan per notes in proprietary procedure above (for alternate proprietary protocol), **[Save Series]** then **[Prep to Scan]**.
7. Right mouse click on **[Research Operations]** and **[Display CVs]**.
8. Set CV saveinter=1<Enter> and **[Accept]**.
9. Click on **[Scan]** (system auto prescans first).

- 10. Display and examine the image of the four sphere phantoms for tweed-like or stripe-like artifacts. See Illustration 2-3. If artifacts are present, use appropriate procedures to troubleshoot the system.
- 11. Click on **[New Series]**. Setup scan prescription for series #1 scan per notes in proprietary procedure above (for alternate proprietary protocol), then repeat steps 9 through 10.
- 12. Display and examine the image of the four sphere phantoms for tweed-like or stripe-like pattern artifacts. See Illustration 2-3. If artifacts are present, use appropriate procedures to troubleshoot the system.

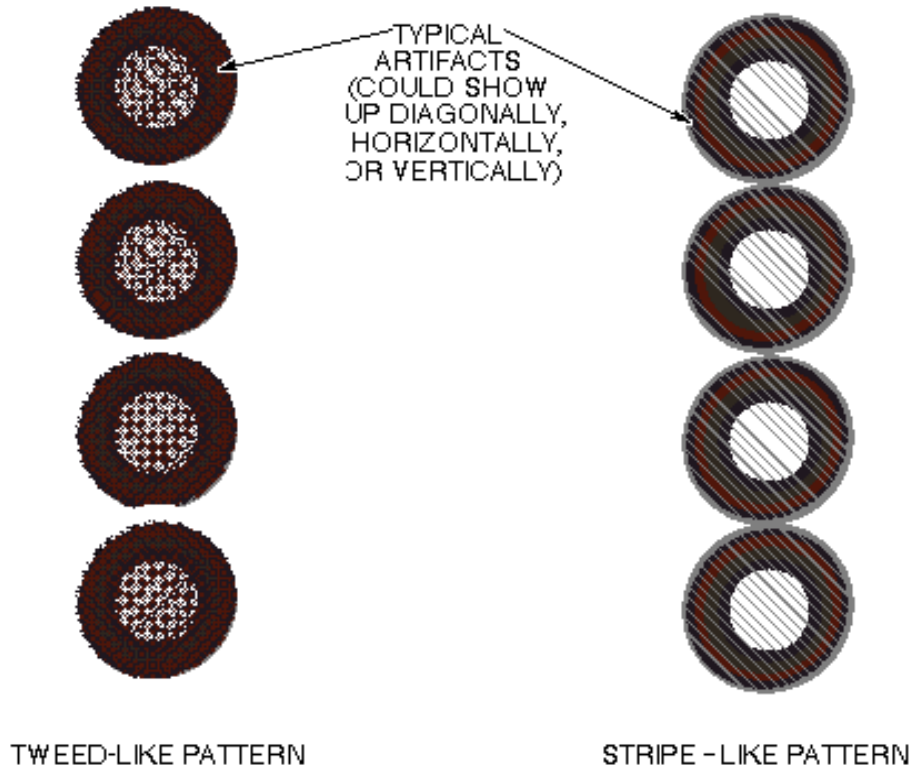

TLT SPHERE WITH TYPICAL ARTIFACTS
ILLUSTRATION 2-3

REVISION HISTORY

REV	DATE	AUTHOR	PRIMARY REASONS FOR CHANGE
0	July 28, 1998	M. Whitlow	Initial conversion from Toolbook to Word.
1	Sept 3, 1998	M. Keber	Removed obsolete 8.1 information; updated format per style guide.
2	Feb. 17, 1999	K. Keshena	Updated per engineering bay validation.
3	Jan 17, 2000	G. Boerner	Changes to landmarking per MRIge56065.
4	Jan 9, 2001	M. Jones	Sec 1-6, step 1: Added instruction to restore all cables to their normal configuration. Sec 1-6, step 9: Added reference to EPI White Pixel TS Guide.