

# TABLE OF CONTENTS

TABLE OF CONTENTS .....	1
1- EQUIPMENT SET UP .....	2
2- ESTABLISHING REFERENCE LEVEL .....	5
3- TESTING RF SHIELDING ATTENUATION.....	7
4- ADDITIONAL TESTING .....	8
REVISION HISTORY.....	10

**Description** - Radio frequency (RF) shielded room testing is performed to check integrity of exam room RF shielding (doors, penetration panels, windows, etc.).

**1- EQUIPMENT SET UP**

**Note**

If RF room testing is done by a vendor, a GE representative must be present and should fill out the required information in this procedure.

Refer to Table 1 for tools and test equipment needed for RF testing (obtain from GE Region Office).

TABLE 1  
**REQUIRED TOOLS AND TEST EQUIPMENT**

Item	Description	Part Number	QTY
1	100 MHz storage oscilloscope, Tektronix® 468 or equivalent	46-183029P61 or P64	1
2	Spectrum analyzer (Textronix model 496)	46-255835P1	1
3	Tuned dipole antennas, (Electrometrics TDA 25)	46-265169P1	2
4	Tape scale, frequency increments (part of Electrometrics TDA 25)		
5	Tripods for dipole antennas	46-265169P2	2
6	RF Power Amplifier (ENI 403LA)	46-265170P1	1
7	RF attenuator (1 dB/step)	46-255838P1	1
8	RF attenuator (10 dB/step)	46-255838P2	1
9	RF test cable kit	46-255816G1	1
10	Surface coil (any GE surface coil will suffice).		1
11	Frequency synthesizer (Model PTS 160 or equivalent)		1

**Note**

RF-shielded room tests can be performed with the magnet at field. The spectrum analyzer and RF power amplifier, however, should be placed outside the 30-gauss zone (approximately 22 ft from 1.5T magnet isocenter).

1. Assemble tripods and antennas outside of exam room, as shown in Illustration L2173A.

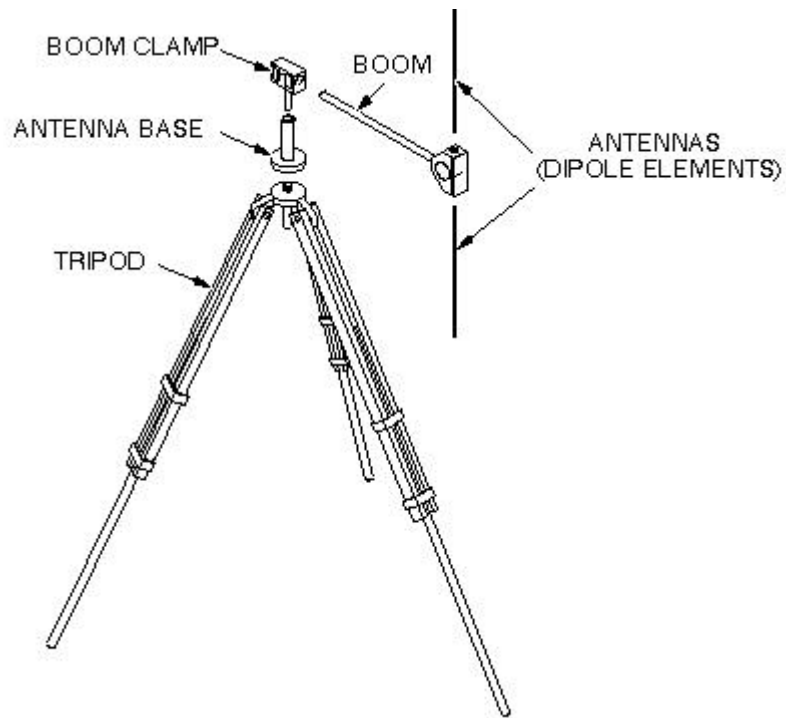

ILLUSTRATION L2173A  
ANTENNA TRIPOD

**Note**

Antennas in the kit are packaged in several lengths. Use those that are 20 inches long (fully contracted).

2. Set each antenna length to 64 mHz for 1.5T system, or 42 mHz for 1.0T system. See Illustration L2174A .

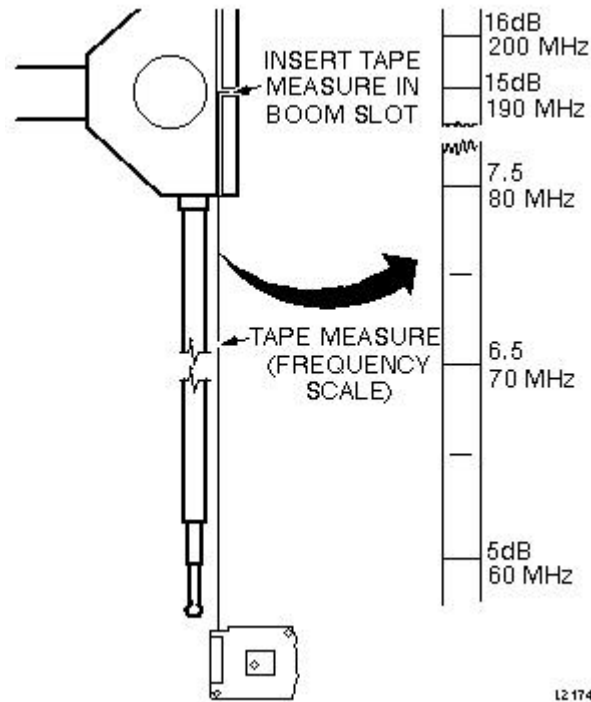
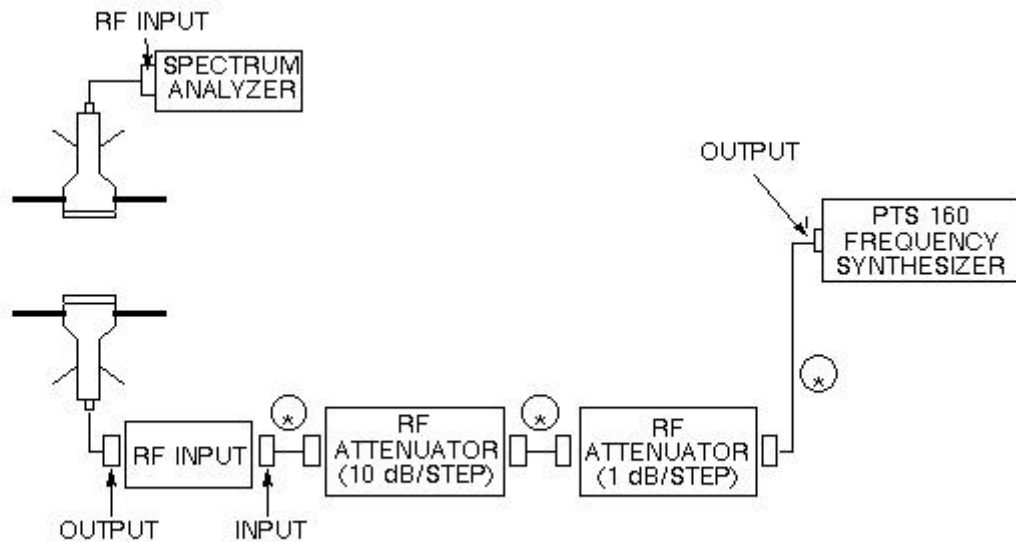

ILLUSTRATION L2174A  
ANTENNA LENGTH

3. Connect all cables as shown in Illustration L2175A.



**NOTE:** (\*) THESE CABLES ARE PART OF RF TEST CABLE KIT: 46 - 255816G1

ILLUSTRATION L2175A CABLE INTERCONNECT DIAGRAM

4. Set PTS 160 frequency synthesizer to LOCAL mode by turning power off, then back on.

5. Manually set PTS 160 frequency synthesizer to 64,000,000 Hz for 1.5T system, or 42,000,000 Hz for 1.0T system.
6. Set the controls on the spectrum analyzer as shown in Table 2.

TABLE 2  
SPECTRUM ANALYZER SETUP

TRIGGERING:	Free	RunPHASE LOCK:	Off
SINGLE SWEEP:	Off	AUTO RESOLUTION:	On
TIME/DIV:	Auto	ZERO SPAN:	Off
F:	Off	FREQUENCY SPAN/DIV:	500 kHz
CAL:	Off	MIN RF ATTEN dB:	50 dB
FREQUENCY:	64 mHz for 1.5T	FINE (2 dB/only):	Off
VERT DISPLAY:	10 dB/Div	MIN NOISE:	Off
VIDEO FILTER:	Wide	REMOTE/ADDRESSED:	Addressed
DIGITAL STORAGE:	View A, B	MIN RF ATTN:	0

**2- ESTABLISHING REFERENCE LEVEL**

**Description**

Prior to performing RF leak testing of the exam room, establish a reference RF level. This is done by placing transmit and receive antennas a fixed distance apart, with no RF barrier between them (i.e., outside of exam room). This distance must be maintained when later testing the RF shielding.

**Procedure**

1. Determine amount of available space around *outside* of exam room in which transmit antenna can be placed.

**Note**

The layout of some sites may not allow access to an outside wall of the exam room. In these cases, testing of the other three walls should suffice in determining the RF integrity of the exam room shielding.

2. Outside of exam room, place both the transmit and receive antennas the desired distance apart (20–70 ft). Record the distance in Data Sheet , RF Shield Test Data.

**Note**

This distance is the length that the transmit antenna can be conveniently placed in the available space around the outside of the exam room.

3. Orient the transmit and receive antennas so they are parallel to each other, and to the ground. See Illustration L2176A .

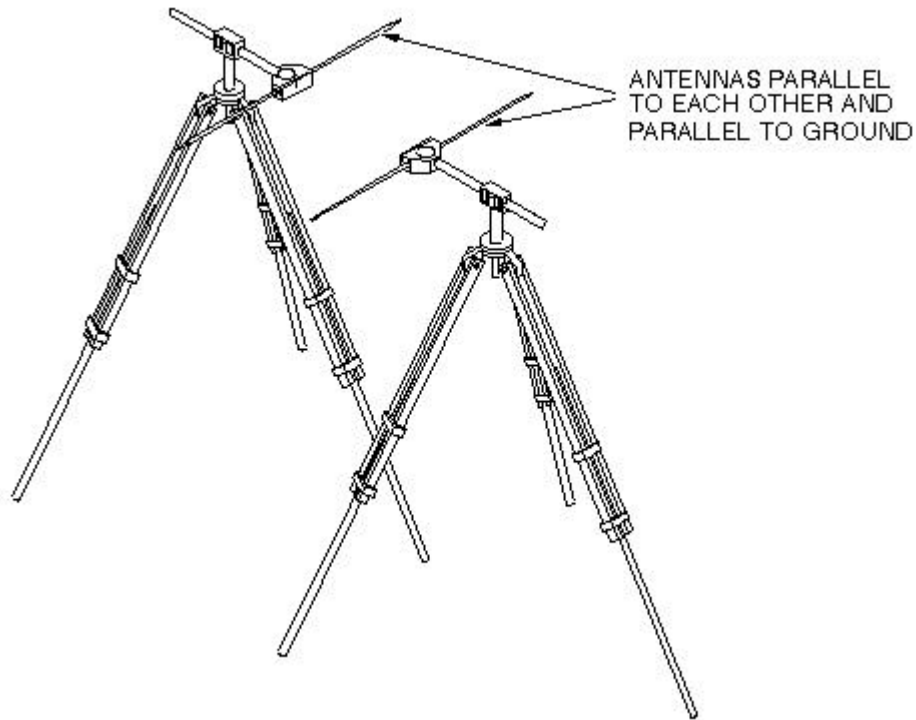

ILLUSTRATION L2176A  
**ANTENNA ORIENTATION FOR REFERENCE**

4. Energize RF test equipment.
5. Turn PTS 160 frequency synthesizer output level to maximum, and adjust RF attenuators (10 dB and 1 dB/step) until peak on spectrum analyzer is 100 dB.

**Note**

Peak level (i.e., 100 dB) is determined by adding the RF ATTENUATION LEVEL to the actual height of the peak. See Illustration L2177A.

See Illustration L2177A , Setting Reference Level to 100 dB.

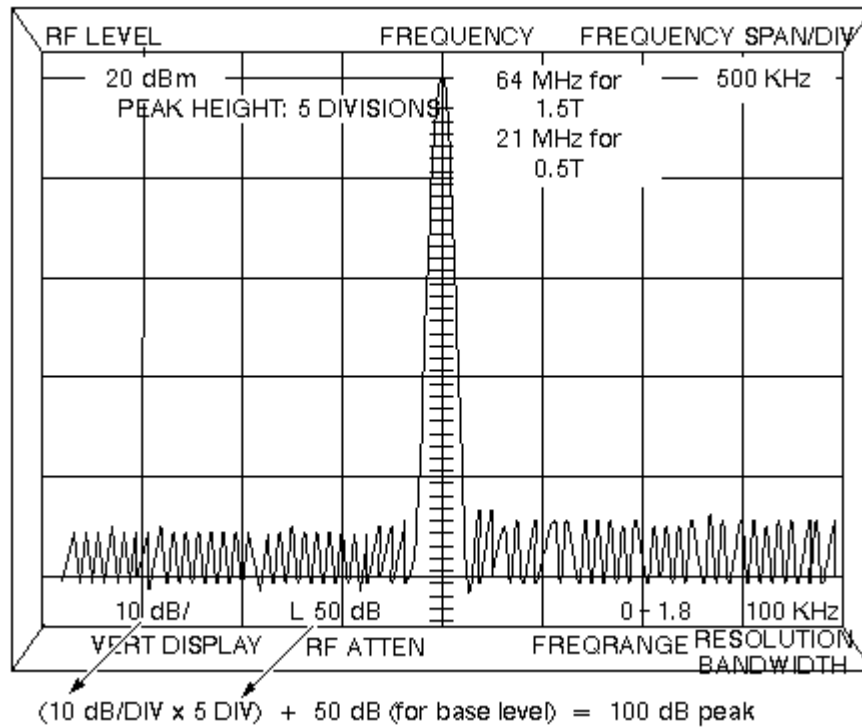

ILLUSTRATION L2177A  
**SETTING REFERENCE LEVEL TO 100 DB**

6. Record RF ATTENUATION in Data Sheet, RF Shield Test Data.
7. Turn off amplifier.

### 3- TESTING RF SHIELDING ATTENUATION

1. Place *receive* antenna *inside* the exam room. Place *transmit* antenna *outside* at the fixed distance (from the receive antenna) determined in previous section.

#### Note

Keep antenna in exam room at least 18 to 24 inches (457.2 to 609.6 mm) from RF shielding wall being tested. Center of room recommended.

2. Orient the transmit and receive antennas parallel to each other, and to the ground.
3. Connect receive antenna cable (inside exam room) to GE penetration panel, PP1J6.
4. On control room side of penetration panel, connect a coaxial cable from PP1J6 to spectrum analyzer.
5. Close all exam room RF doors.
6. Check penetration panel for openings. Ensure that penetration panel circular feed-throughs are capped, or covered with copper tape.

7. Test RF attenuation of all four walls, if possible, by placing antennas in orientations shown in Illustration L2178A.
8. Record attenuation level for locations A, B, C, and D in Data Sheet, RF Shield Test Data.
9. Store completed data sheets in *Direction 15403, Signa Advantage / Horizon Data, System* tab, or on a floppy disk for future reference.

**Note**

See Illustration L2179A for calculating RF attenuation of a particular wall.

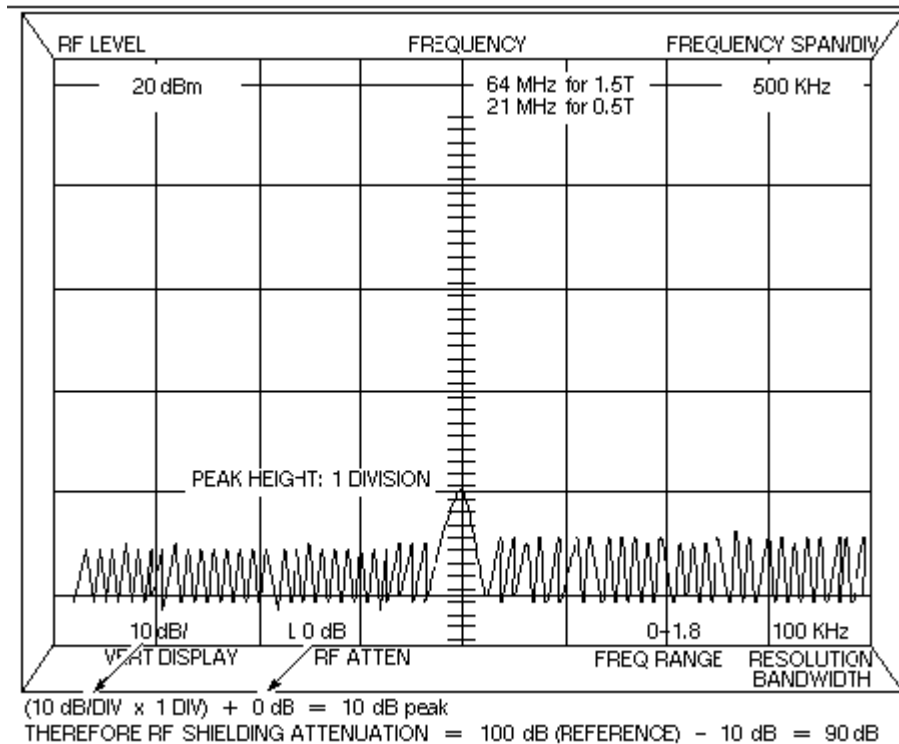

ILLUSTRATION L2179A  
**CALCULATING RF ATTENUATION - TYPICAL PEAK**

**4- ADDITIONAL TESTING**

**Description**

If the attenuation of the RF shielding is less than 100 dB, additional testing can be performed with an MR surface coil to determine the exact location of the leak (typically around doors, windows, wall seams, penetration panel, etc.).

**Procedure**

1. Disconnect coaxial cable from receive antenna and connect to MR surface coil.
2. Establish a reference level between the surface coil and the transmit antenna. This reference is only for your reference.

**Note**

Rotate coil to maximize receive peak. Typically, the strongest signal is obtained when coil surface is parallel to ground.

3. Place the transmit antenna outside the exam room, parallel to the suspect wall.
4. Within exam room, move surface coil along suspect area of RF leaks.
5. Record attenuation levels in Data Sheet, RF Shield Test Data.
6. Store completed data sheets in *Direction 15403, Signa Advantage / Horizon Data, System* tab, or on floppy disk for future reference.

### REVISION HISTORY

REV	DATE	AUTHOR	PRIMARY REASONS FOR CHANGE
0	Aug 19, 1998	R. Hawthorne	Initial conversion to Word