

# TABLE OF CONTENTS

|   |          |
|---|----------|
| <b>1- RESPIRATORY COMPENSATION CHECKOUT (ROCKER).....</b> | <b>2</b> |
| 1-1 Tools Required.....                                   | 2        |
| 1-2 Procedure .....                                       | 2        |
| <b>REVISION HISTORY.....</b>                              | <b>6</b> |

## 1- RESPIRATORY COMPENSATION CHECKOUT (ROCKER)

**Description** - This test uses the respiratory compensation bellows and Rocker software tool to verify proper operation of the respiratory compensation hardware and software.

### 1-1 Tools Required

| Item | Description         | Part Number | Qty. |
|------|---------------------|-------------|------|
| 1.   | Respiratory Bellows | 46-265679G1 | 1    |

### 1-2 Procedure

#### Note

Never vent the bellows. Always connect the bellows to the PAC Assembly before attaching it to patient table and cradle. Failure to connect bellows to PAC Assembly first causes inaccurate waveforms and, therefore, inaccurate results.



**Possible equipment damage. Completely remove the Quad Head Coil from the cradle before performing any body scans. Failure to do so may damage the head coil T/R network.**

1. At the Operator Workspace, select the scan icon in the desktop control panel.
2. If necessary, exit out of any previous exams by selecting **[End Exam]**.
3. Click on **[New Pt]** and enter the following:  
Id: **geservice**  
Name: **resp comp**  
Weight (Lb.): **111**



**POISON HAZARD! THE PHANTOM CONTAINS NICKEL, A SUSPECT CARCINOGEN. DO NOT INGEST. DISPOSE OF AS A HAZARDOUS WASTE ACCORDING TO STATE AND FEDERAL REGULATIONS.**

4. Remove Quad Head Coil (if present) from the cradle. At keypad magnet front enclosure, press LANDMARK. Landmark near where the center of the head coil would be.
5. Using the OUT SLOW button, move the cradle out about 30 millimeters. This should allow enough room for the bellows on the table.
6. Connect the respiratory bellows to the PAC Assembly.

- Place the respiratory bellows on the patient table and tie one end to the handle on the table as shown in Illustration 1-1. Be sure that the bellows is tied to one side of the handle so that it does not wrap around the release bar; otherwise, the table could unlatch when Rocker starts.

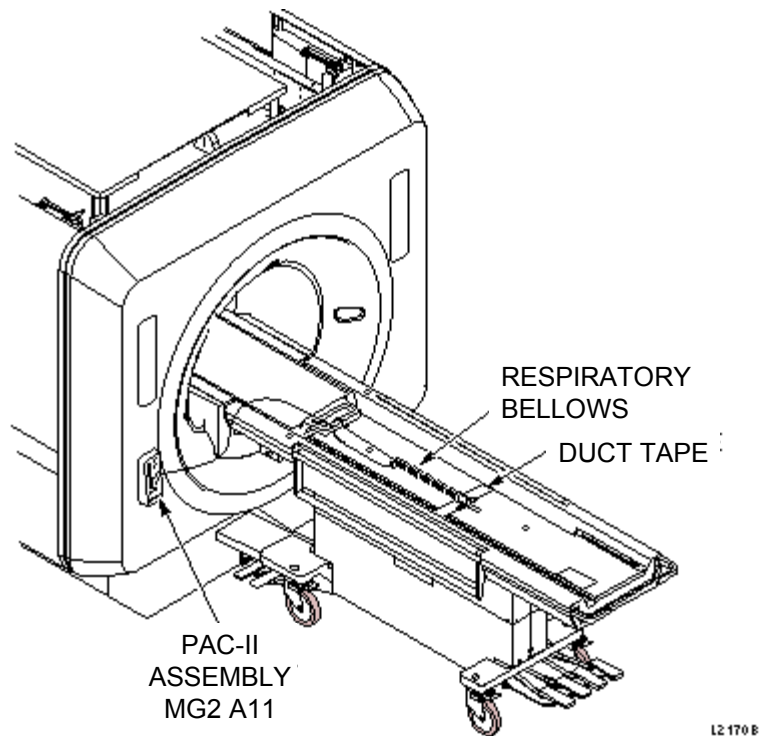

**BELLOWS SET-UP**  
ILLUSTRATION 1-1

- Tape the other end of the bellows with tape so that the bellows is slightly stretched (approximately 11 inches long end-to-end).
- Press ADV TO SCAN.
- The Message window must be clear before continuing. If the window is not clear, click on the **Message** bar area, and click **[Clear]**, then **[Close]**.

*The following three steps are **proprietary** and only available for GE use, and to sites with a valid Advanced Service Package Limited License. The non-proprietary procedure is listed after these steps.*

- Set Patient Protocols to **Service**.
- In the Protocol field, Type **o.31.1** (o=Other, 31=protocol number, 1=series number).  
**OR**  
Click on "Other" and select protocol **31** and series **1** from the menu.
- Click on **[Accept]** to load the protocol.

**Non-proprietary procedure:**

At the Operator Workspace, prepare the system for a "Respiratory Compensation" scan using the scan protocol (o.31.1) shown in the "Service Protocols" procedure located on the service methods CD-ROM.

- 14. Click on **[Save Series]**, then **[Prepare to Scan]**.
- 15. Select **[Respiratory]**, from the Gating Control Menu. The Respiratory waveform appears below the BPM waveform on the LCD Panel Display.

**Note**

The scan protocol must be completed to activate Respiratory Compensation software and hardware. No scan is executed in this procedure.

**Note**

If you reset the TPS while the Rocker Test is running, error messages are produced when you try to start the table rocking, or try to stop the Rocker Test; therefore, do not reset TPS while using the test, and do not let the test run for excessive time periods (this increases the chance that the TPS may be reset while the test is running). If the Rocker Test should fail due to the TPS being reset, exit that test and start a new one.

- 16. From the Service Desktop, select **Rocker** from the **[Cal/Checks]** menu. If you need help, see the User Interface Tutorial. A Rocker window opens and the Rocker Main Menu appears, as shown in Illustration 1-2

-----= Rocker Main Menu -----

- 1) Start table rocking.
- 2) Change speed.
- 3) Stop rocking.
- 4) Get help.
- 5) Exit main menu.

```

Please select an option (1..5) : ..... 1 <Enter>
Enter the distance of table travel in mm (-100..100): .. 6 <Enter>
Enter the peak velocity in mm/sec (1..100) : ..... 3 <Enter>
Enter the wait time in 1/10 sec increments (0..60) : ... 3 <Enter>
Enter the decay factor (0..100) : ..... 0 <Enter>

```

Attention: The table will start rocking when the next carriage return is entered. Make sure it is safe to start table rocking, then enter a carriage return. [ ] : ... Verify that there are no obstructions near the cradle before continuing, then <Enter>.

\*\*\* The table should start rocking \*\*\*

**ROCKER MAIN MENU**  
ILLUSTRATION 1-2

- 17. On the Rocker Main Menu, select Start table rocking. (Verify that Respiratory Bar Graph on PAC Assembly is registering rhythmic change of bellows.)

18. After approximately 30 seconds, verify that Resp OK is displayed in Message window, and that Resp rate display 15 to 21 (20 is optimal).

19. On the Rocker Main Menu select [**Stop rocking**] shown in Illustration 1-3.

Enter a carriage return to continue [ ]:..... <Enter>  
-----= Rocker Main Menu =-----

- 1) Start table rocking.
- 2) Change speed.
- 3) Stop rocking.
- 4) Get help.
- 5) Exit main menu.

Please select an option (1..5) : ..... 3 <Enter>

\*\*\* The table should stop at the end of the current cycle. \*\*\*

Enter a carriage return to continue [ ]: ..... <Enter>

**ROCKER MAIN MENU - STOPPING**  
ILLUSTRATION 1-3

20. The Rocker window closes automatically when exited. To manually exit, select **Exit** from the window function handle (*upper, left corner of window*) to close the window.

## REVISION HISTORY

| REV | DATE          | AUTHOR         | PRIMARY REASONS FOR CHANGE   |
|-----|---------------|----------------|--|
| 0   | 01/04/96      | M. Keber       | Initial Release  |
| 1   | 07/02/96      | J. Johnson     | Update to Lx format  |
| 2   | 05/19/97      | WEK            | Updated to 8.1 protocols; added class A Rx #   |
| 3   | 10/23/97      | K. L-P         | Updated procedure to agree with system buttons   |
| 4   | Nov 4, 1998   | M. Keber       | Removed obsolete 8.1 information; misc. style guide cleanup.   |
| 5   | May 20, 1999  | S.M.Atladottir | Updated Procedure Reference for New GUI  |
| 6   | Dec 31, 1999  | G. Boerner     | Landmarking per SPR MRIge56065 and minor edits per 8.3 validation.   |
| 7   | Feb. 17, 2000 | R. Kaufman     | Changed start-up from Troubleshoot to CAL/CHECKS   |
| 8   | Mar 27, 2001  | M. Keber       | Removed obsolete Section 2, Respiratory Bellows Test, per MRIge65442 (diagnostic for this test was removed in 1997). |
|     |               |                |  |
|     |               |                |  |