

## SECTION 4 - GRADIENTS

### TABLE OF CONTENTS

<u>SECTION</u>	<u>TITLE</u>	<u>PAGE</u>
4-	<b>GRADIENT OVERVIEW</b> .....	<b>4-2</b>
4-1	CHECK GRADIENT CABINET FANS AND FILTERS.....	4-4
4-2	CHECK EDDY CURRENT COMPENSATION .....	4-12
4-3	CHECK GRADIENT CABLE CONNECTIONS AND SUPPORT.....	4-13
4-4	CHECK GRADIENT CALIBRATION .....	4-24
4-5	CHECK FLUID LEVEL AND VALVE OF HEAT EXCHANGER FOR GRADIENT COIL COOLING .....	4-24
4-6	CHECK WATER CHILLER FOR GRADIENT COIL COOLING .....	4-26

**4- GRADIENT OVERVIEW**

There are a number of possible gradient hardware configurations that support Signa Horizon 5.x, 8.x, 9.x & 10.x systems. There are 4 performance levels of gradient driver subsystem and three generations of cabinets for each performance level. The performance levels are defined in terms of slew rate as follows:

- SR20 - Base Performance
- SR50 - SmartSpeed
- SR77 - HiSpeed
- SR120 - EchoSpeed

The 4 generations of gradient hardware are 8645/GRAM 1, SGD (Scaleable Gradient Driver) and the ACGD (Advance Control Gradient Driver). The following illustrations show the 6 possible hardware configurations for the Signa systems.

**EchoSpeed (SR120) Gradient Driver**

EchoSpeed performance achieved with ACGD Cabinet, SGD HiSlew Cabinet or an 8645 (double bay) and GRAM 1-Cabinet.

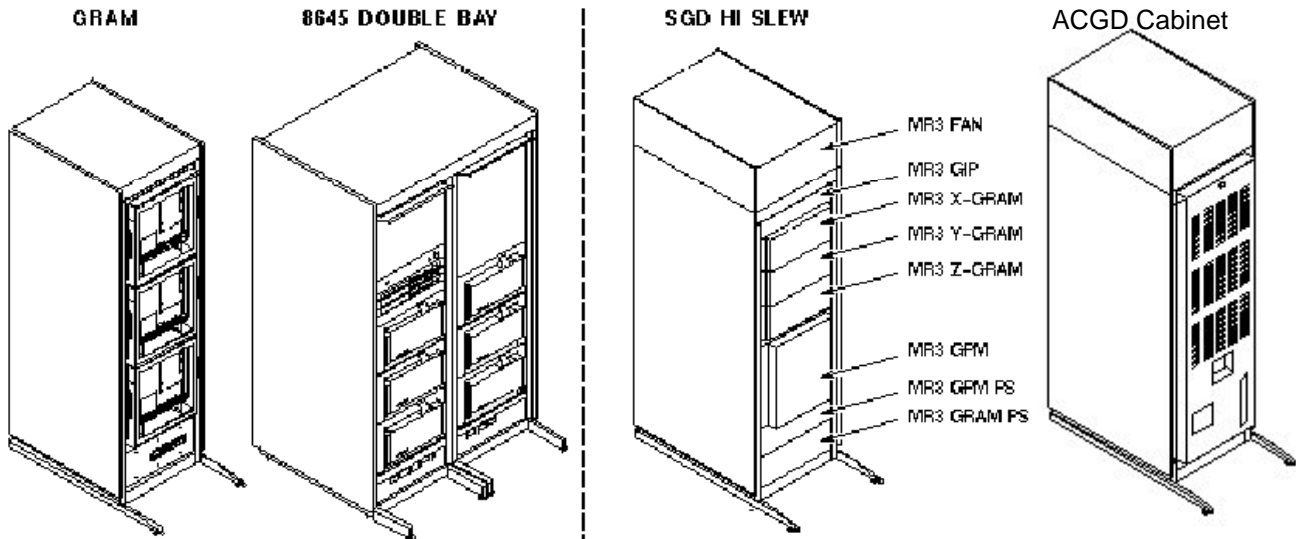

**ECHOSPEED (SR120) GRADIENT DRIVER (8645/GRAM VS. SGD HISLEW)**  
 ILLUSTRATION 4-1

**4- GRADIENT OVERVIEW (continued)**

**HiSpeed (SR77) Gradient Driver**

HiSpeed performance achieved with an ACGD Cabinet, SGD HiSlew Cabinet or an 8645 (single bay) and GRAM 1 Cabinets.

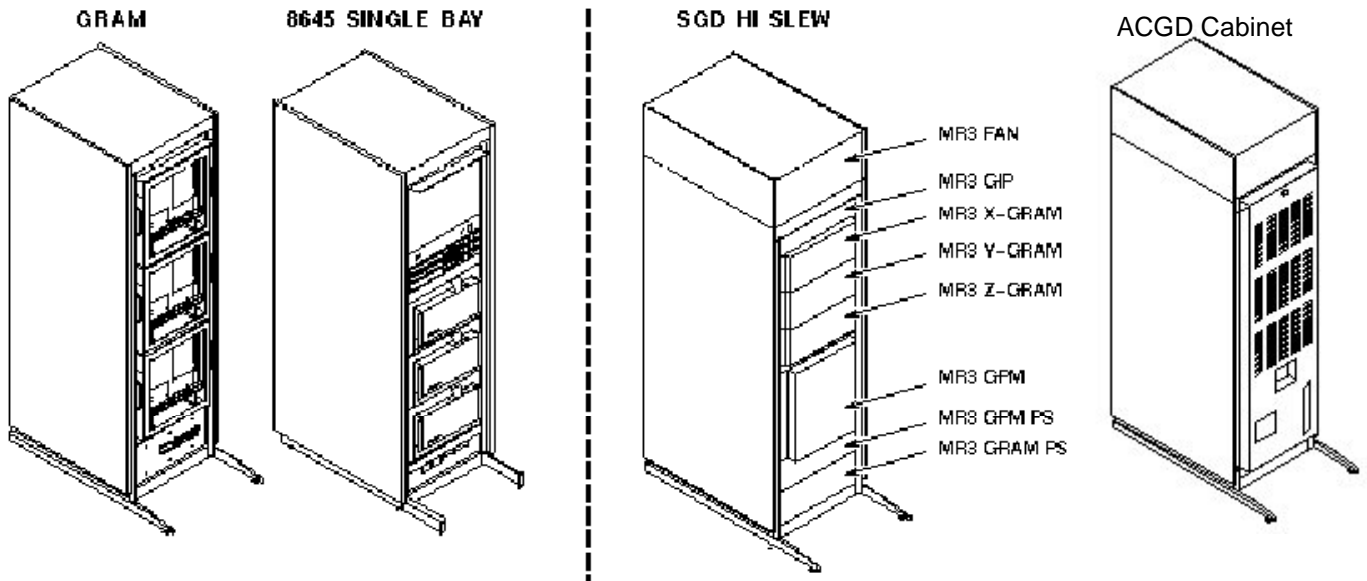

HISPEED (SR77) GRADIENT DRIVER (8645/GRAM 1 VS. SGD HISLEW)  
 ILLUSTRATION 4-2

**ACGD Lite (SR50) Gradient Driver**

SmartSpeed performance is achieved with either the ACGD Lite Cabinet or an ACGD Cabinet.



SMARTSPEED (SR50) GRADIENT DRIVERS  
 ILLUSTRATION 4-3

**SGD Base (SR20) Gradient Driver**

Base performance achieved with either the SGD Base Cabinet or an 8645 (double bay) Cabinet.

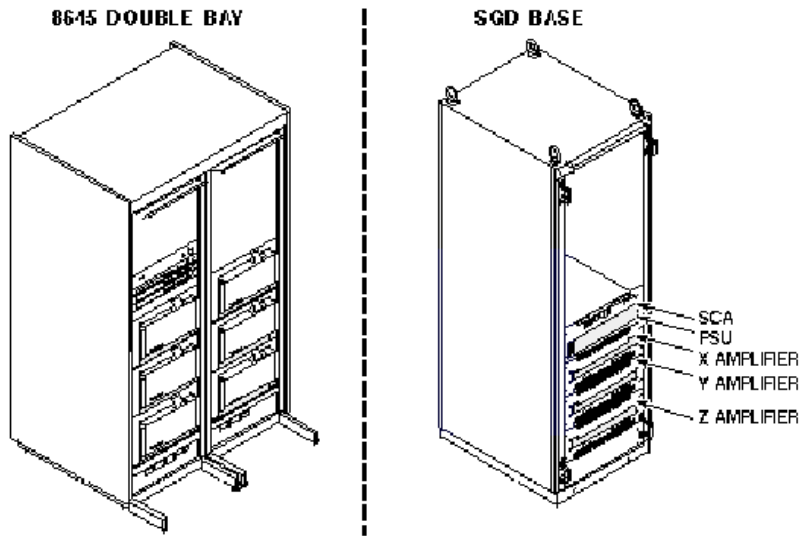

**BASE (SR20) GRADIENT DRIVER (8645 VS. SGD BASE)**  
ILLUSTRATION 4-4

### 4-1 CHECK GRADIENT CABINET FANS AND FILTERS

#### 8645 Gradient Cabinet

1. Remove cover(s) from front of Gradient Cabinet. See Illustration 4-5.

**Note**

The 8645 Gradient Cabinet filters may be cleaned rather than replaced. Depending on the environment, the filters should be cleaned approximately once each year. Shake or vacuum the filters to remove major particles. Wash the filters using any detergent and water. When the filters are dry, apply a filter spray coat.

Unless you are replacing a filter due to physical damage, replace all the filters at the same time. To replace a filter, lift up and pull out from the bottom edge.

2. Remove and check four Gradient Amplifier filters in the Single-Bay 8645 Cabinet or eight filters in the Double-Bay 8645 Cabinet. Replace filter(s) (46-306565P1) as needed.



**FATAL ELECTRIC SHOCK HAZARD!! GRADIENT AMPLIFIERS MAY HAVE TOP COVERS REMOVED; EXPOSING THE OUTPUT WELLS, WHICH ARE AT A HIGH VOLTAGE. TO PREVENT ELECTRIC SHOCK, DO NOT TOUCH OR PLACE ANYTHING ON EXPOSED OUTPUT WELLS.**

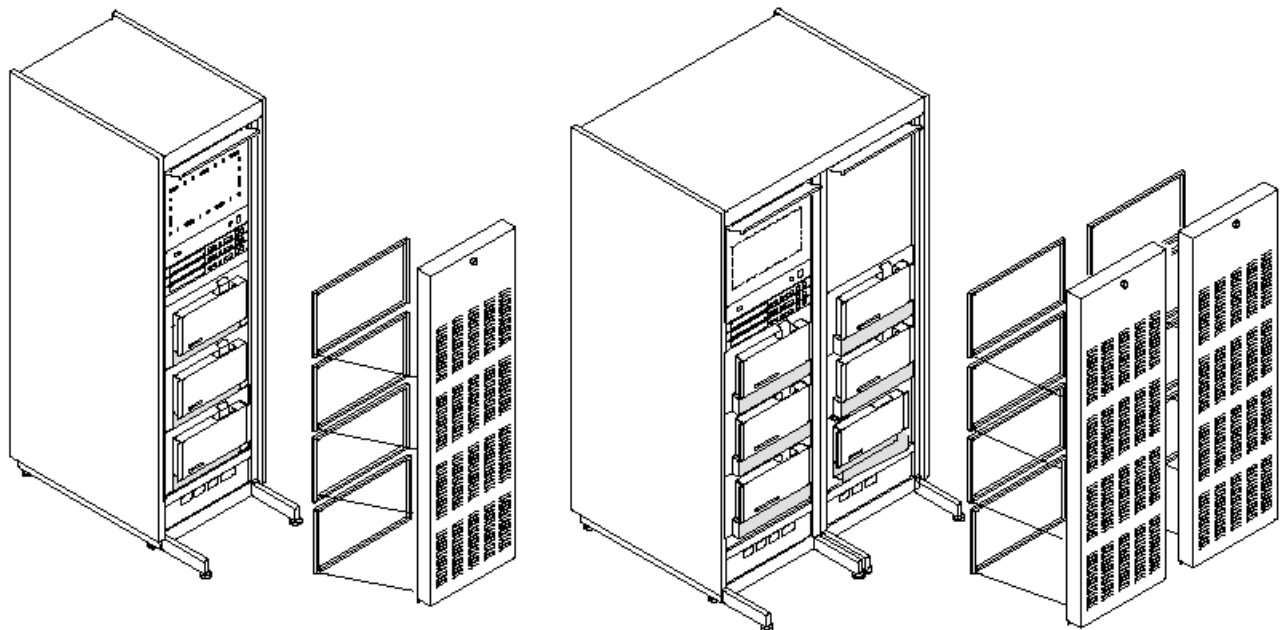

SINGLE-BAY 8645 GRADIENT CABINET

DOUBLE-BAY 8645 GRADIENT CABINET

GRADIENT CABINETS WITH COVERS AND FILTERS

ILLUSTRATION 4-5

**4-1 CHECK GRADIENT CABINET FANS AND FILTERS (continued)**

**Note**

The operation of the fans can be observed from the rear of the cabinet. Ensure that Fans are operating at proper speed and not “free wheeling.”

3. Open rear cabinet doors. Using a small ty-wrap, check operation of the Fans for each Gradient Cabinet located in the top of the 8645 Gradient Cabinet. See Illustration 4-6.

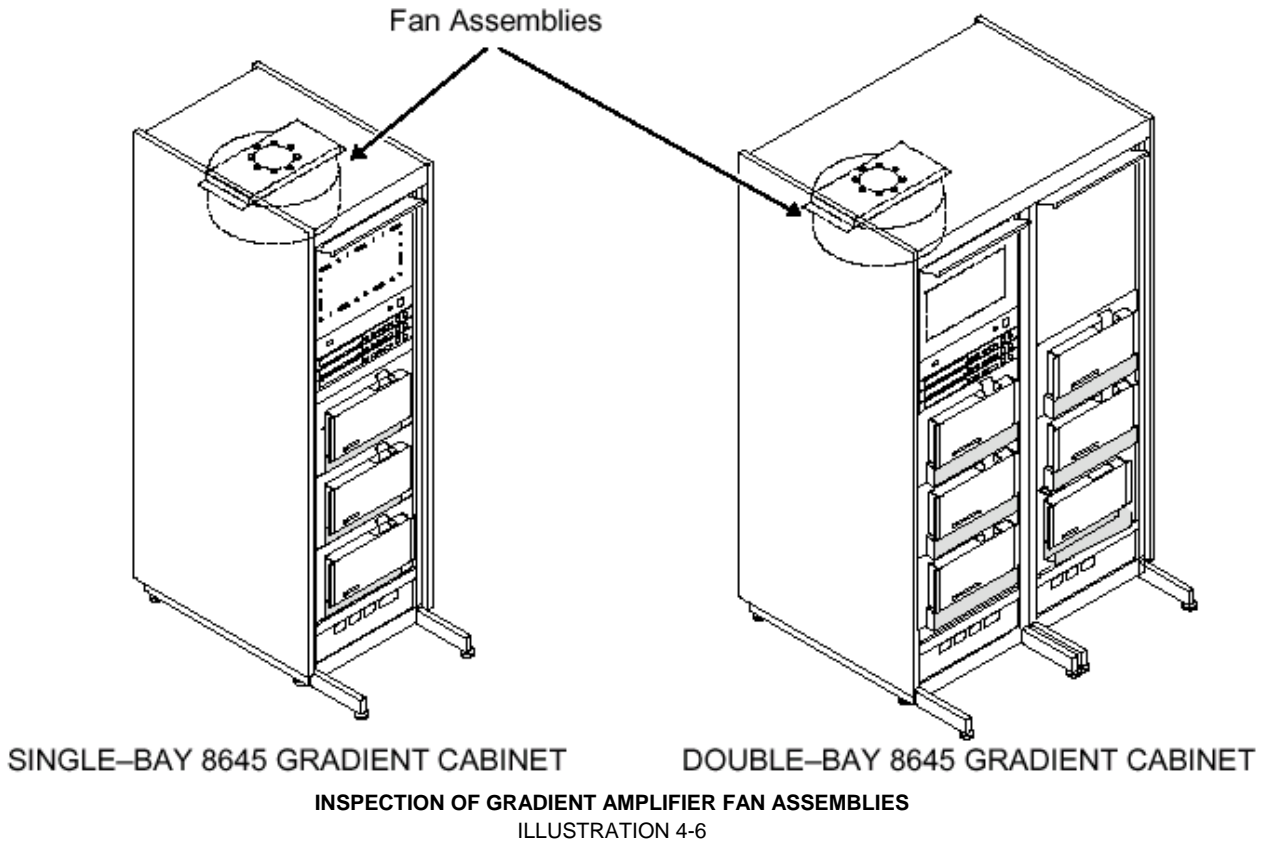

4. If fans are not operating properly remove and replace with Fan Assembly 46-328206P28.
5. Close rear doors.

**4-1 CHECK GRADIENT CABINET FANS AND FILTERS (continued)**  
**SGD Base (SR20)**

**Note**

The SGD Base Cabinet filter may be cleaned rather than replaced. Depending on the environment, the filter should be cleaned approximately once each year. Shake or vacuum the filter to remove major particles. Wash the filter using any detergent and water. When the filter is dry, apply a filter spray coat.

1. Remove rear cover from the Gradient Cabinet. See Illustration 4-7.

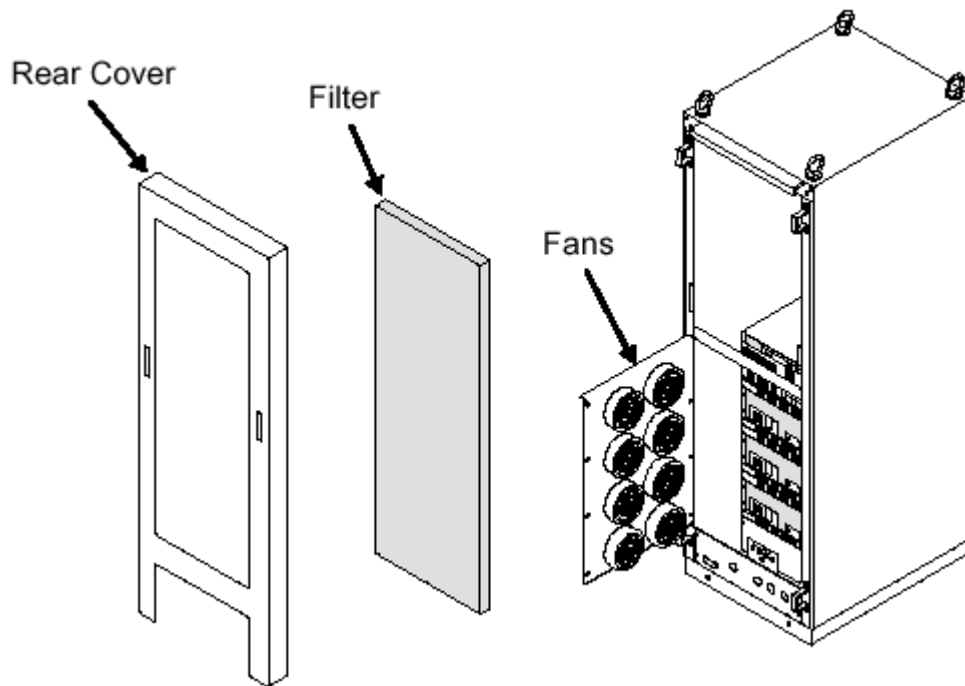

**SGD (SR20) BASE GRADIENT CABINET**  
 ILLUSTRATION 4-7

2. Remove and check filter in the SGD (SR20) Base Cabinet by lifting up and pulling out from the bottom edge. Replace filter (2226910) as needed.

**Note**

The operation of the fans can be observed from the rear of the cabinet. Ensure that Fans are operating at proper speed and not “free wheeling.”

3. Open rear cabinet door. Using a small ty-wrap, check operation of the Fans. See Illustration 4-7.
4. If fans are not operating properly remove and replace with Fan Assembly 2176114.
5. Close rear doors.

**4-1 CHECK GRADIENT CABINET FANS AND FILTERS (continued)**  
**GRAM Cabinet**

The three GRAM air filters (46-306565P1) are located inside the cabinet front cover. The filters should be cleaned or replaced on a periodic basis to ensure proper cabinet cooling. See Illustration 4-8.

**Note**

The GRAM filters may be cleaned rather than replaced. Depending on the environment, the filters should be cleaned approximately once each year. Shake or vacuum the filters to remove major particles. Wash the filters using any detergent and water. When the filters are dry, apply a filter spray coat.

Unless you are replacing a filter due to physical damage, replace all the filters at the same time. To replace a filter, lift up and pull out from the bottom edge.

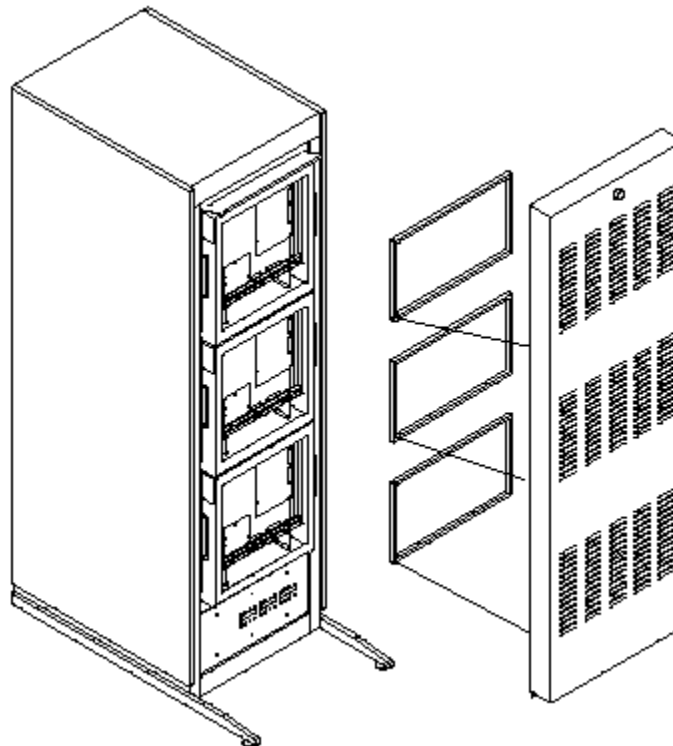

**GRAM CABINET FILTER LOCATIONS**  
ILLUSTRATION 4-8

**4-1 CHECK GRADIENT CABINET FANS AND FILTERS (continued)**

Ensure that Fans are operating at proper speed and not “free wheeling.” Open rear cabinet door, Fans are located on the top of each GRAM Module. Using a small ty-wrap, check operation of the Fans for each GRAM Module. See Illustration 4-9.

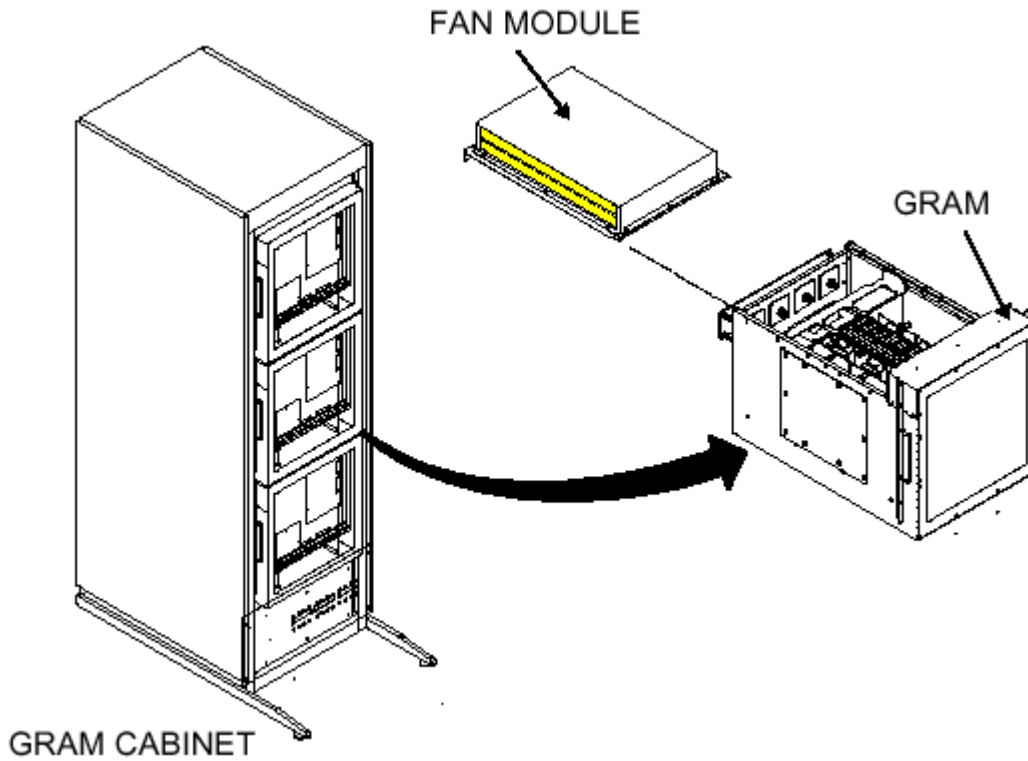

**GRAM CABINET FAN LOCATIONS**  
ILLUSTRATION 4-9

If fans are not operating properly, remove and replace with Fan Module 46-328311G1.

**4-1 CHECK GRADIENT CABINET FANS AND FILTERS (continued)**  
**SGD Hi-Slew Cabinet**

The four SGD air filters are located inside the cabinet front cover. The filters (46-306565P1) should be cleaned or replaced on a periodic basis to ensure proper cabinet cooling. See Illustration 4-10.

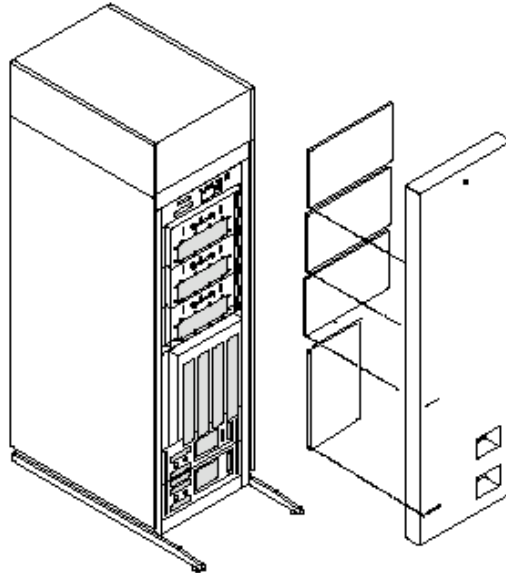

**SGD HI-SLEW GRADIENT CABINET FILTER LOCATIONS**  
ILLUSTRATION 4-10

Verify the fan is operating properly. Using a piece of paper, hold over fan on the top of the cabinet (see Illustration 4-11), airflow should cause paper to stand up. The fan should create enough suction to hold the rear cabinet door closed. If fan is not operating properly remove and replace with Fan Assembly 2181131.

FAN ASSEMBLY

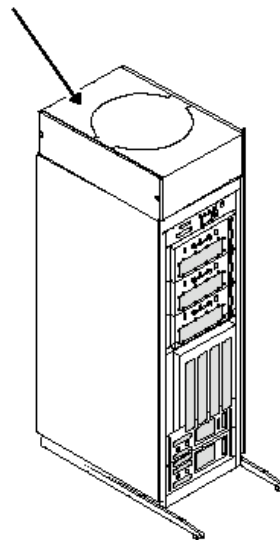

**SGD HI-SLEW GRADIENT CABINET FAN LOCATION**  
ILLUSTRATION 4-11

**4-1 CHECK GRADIENT CABINET FANS AND FILTERS (continued)**  
**ACGD Cabinet**

The four ACGD air filters are located inside the cabinet front cover. The filters (2284074) should be cleaned or replaced on a periodic basis to ensure proper cabinet cooling. See Illustration 4-12.

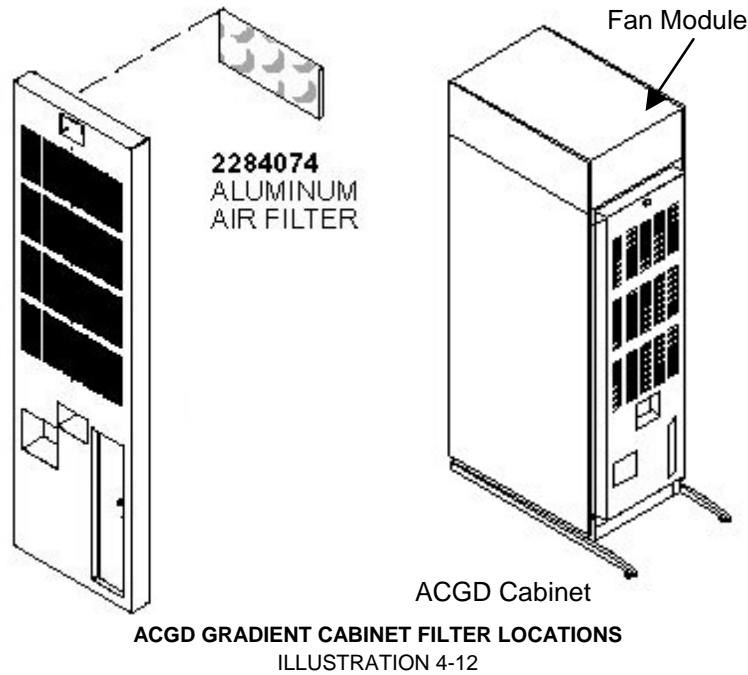

Verify the fan is operating properly. Using a piece of paper, hold over fan on the top of the cabinet (see Illustration 4-12), airflow should cause paper to stand up. The fan should create enough suction to hold the rear cabinet door closed. If fan is not operating properly remove and replace with Fan Assembly 2299215.

**4-2 CHECK EDDY CURRENT COMPENSATION**

**For Software Release Versions 9.0 and earlier:**

Eddy current compensation cannot be checked by data from SPT. The only method to check the Eddy Current compensation is to run an iteration of Grafidy in each axis. If the readings are within specification the Eddy Current Compensation is OK. If any of these are out of specification, schedule time to adjust them.

For the latest revision of the Grafidy procedure refer to the 8.X CD ROM.

**For Software Release Versions 9.1 (and later) & 10.x Only:**

Eddy current compensation is checked using data from SPT. (Refer to Appendix E, Section E-1-2, Viewing Results and Calibration Files.)

1. Verify there is a SPT file that was run within the last month. If not, run SPT now. (Refer to APPENDIX E, SYSTEM PERFORMANCE TEST.)
2. Verify that SPT Eddy Currents is within specification.
3. If all of the eddy currents for all three axes are within specification, the Eddy Current compensation is OK. If any of these are out of specification, schedule time to adjust them.

4-3 CHECK GRADIENT CABLE CONNECTIONS AND SUPPORT



**FATAL SHOCK HAZARD!! LETHAL VOLTAGES EXIST AT GRADIENT CONNECTIONS. FOLLOW THE STEPS BELOW EXACTLY. FAILURE TO DO SO COULD RESULT IN SEVERE INJURY OR DEATH.**

**8645 Gradient Cabinet**

1. Lock out and tag out the PDU Circuit Breaker for the GRAM Cabinet and the 8645 Gradient Amplifier Cabinet using appropriate OSHA procedure. (Refer to CD-ROM *Dir. 2187583-1, MR Release Signa 5x/8x Service Methods, Renewal Parts and Service Tools, Safety, Section 6, OSHA LOCKOUT/TAGOUT REQUIREMENTS.*)
2. Verify that all energy has been dissipated by measuring incoming power to the GRAM Cabinet at TS1 (see Illustration 4-11). Verify that all energy has been dissipated for the 8645 Gradient Amplifier Cabinet by measuring power at TS1. Also see Illustration 4-12 for Signa HiSpeed system, or Illustration 4-13 for Signa Base or EchoSpeed systems.

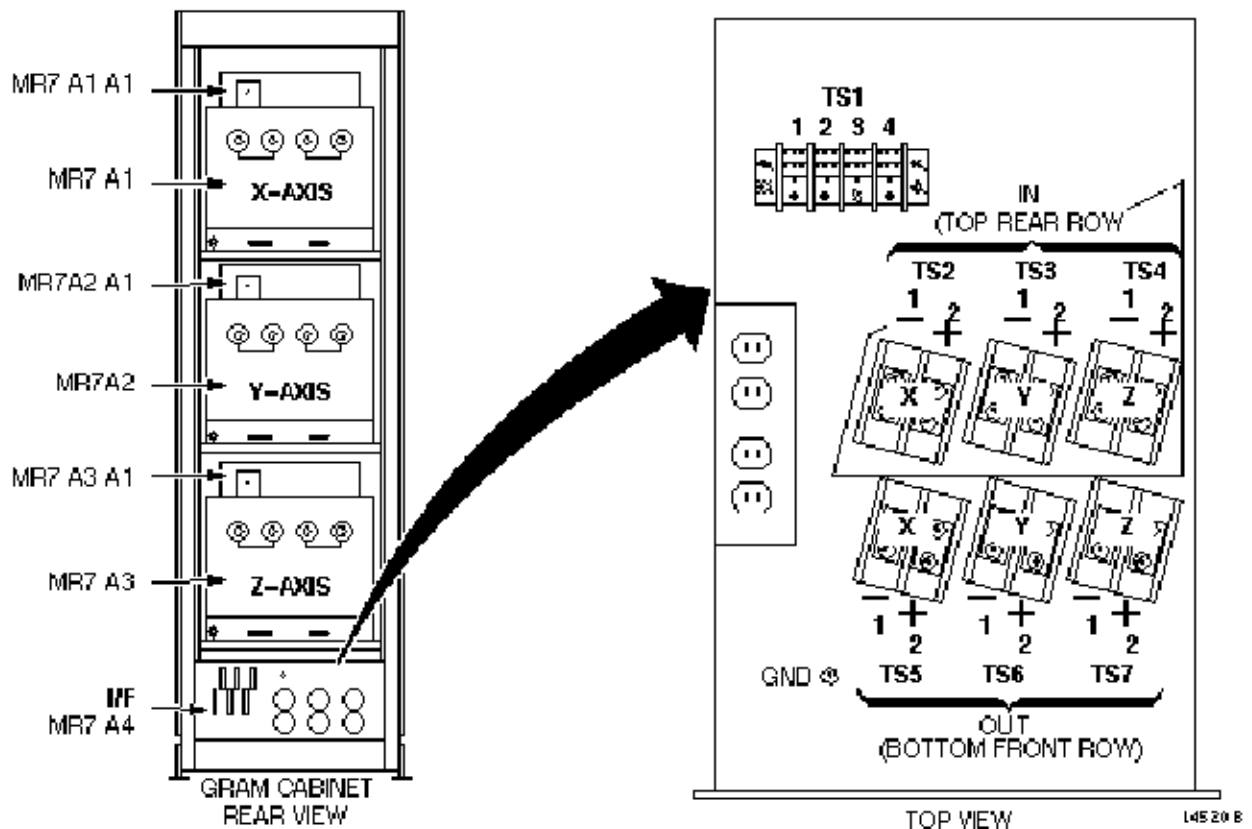

GRAM CABINET, REAR VIEW – BOTTOM PANEL AND TS1  
 ILLUSTRATION 4-11

4-3 CHECK GRADIENT CABLE CONNECTIONS AND SUPPORT (continued)

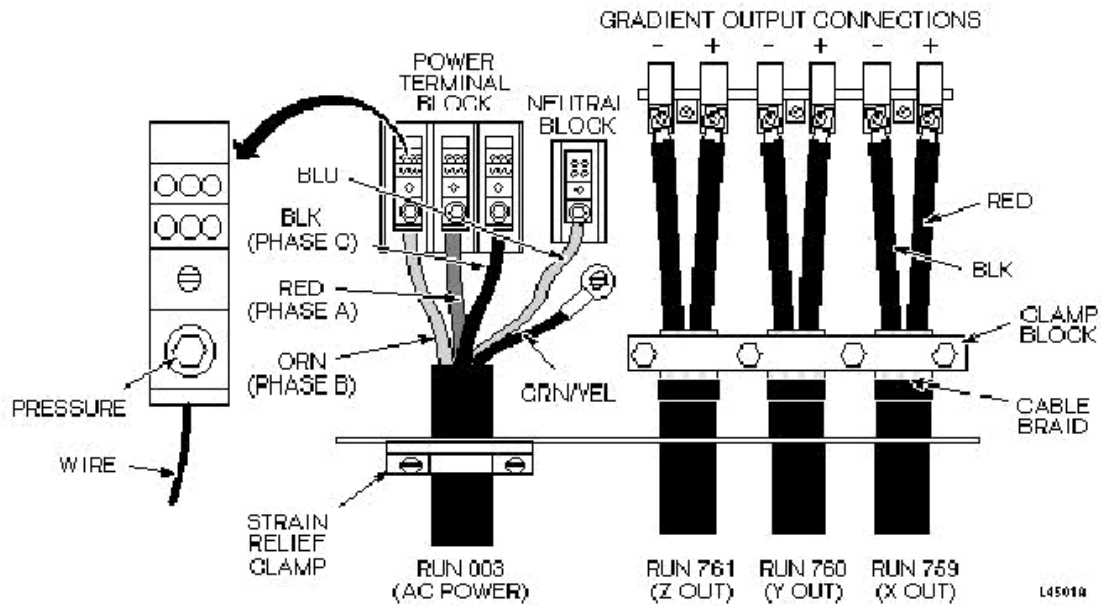

8645 CABINET POWER AND OUTPUT CABLE CONNECTIONS  
 ILLUSTRATION 4-12

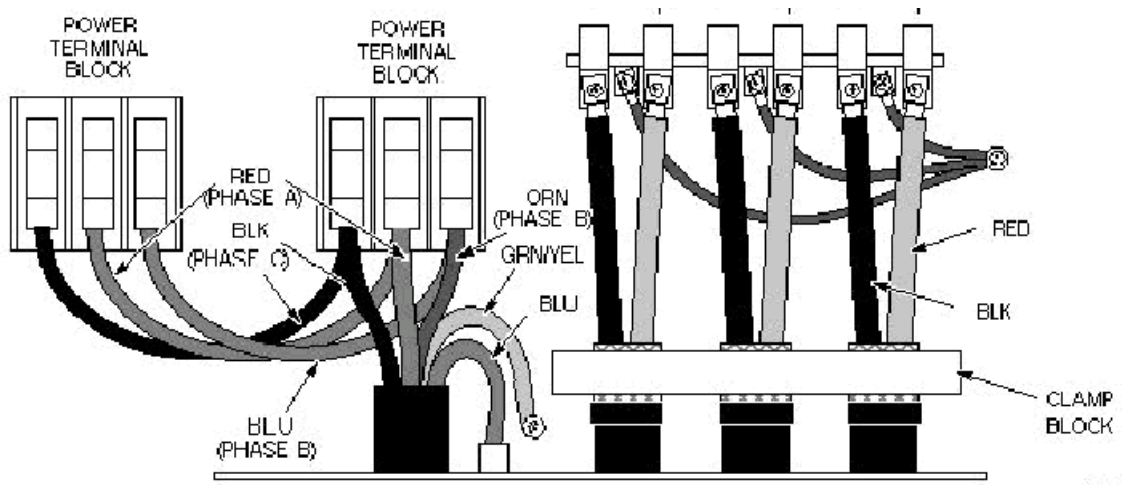

INCOMING POWER TO A DOUBLE-BAY 8645 GRADIENT CABINET  
 ILLUSTRATION 4-13

- Verify gradient cable connections are secure at the Gradient Amplifiers, Gradient Cabinet Interface, GRAM Modules at the GRAM Cabinet, both sides of Penetration Panel, and gradient cable terminal strip at rear pedestal. See Illustration 4-14 for overall diagram of gradient cable connections. See Illustrations 4-14 through 4-16 for connection details.

**Note**

The new longer brass nuts (46-136375P27) should be installed on the Gradient Filter Box to insure that threads are not stripped when tightening connections. (See Illustration 4-15.)

**4-3 CHECK GRADIENT CABLE CONNECTIONS AND SUPPORT (continued)**

- Verify that the gradient cable bundle coming from the Body Coil is well supported/ty-wrapped. See Illustration 4-14.

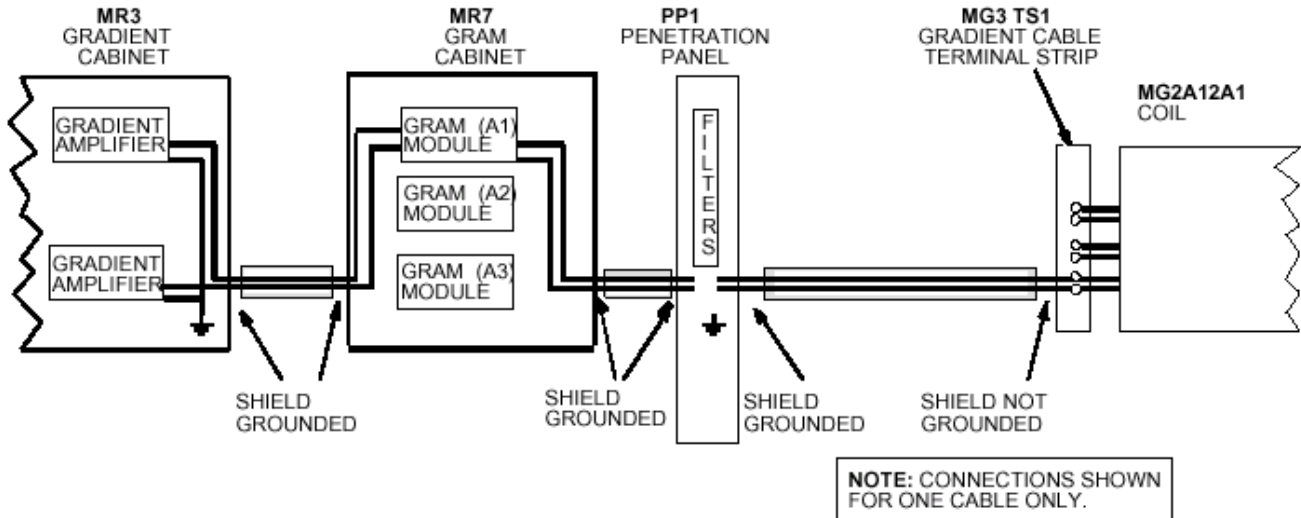

**GRADIENT CABLE CONNECTIONS**  
 ILLUSTRATION 4-14

- On the Control Room side of the Penetration Panel, remove the cover of the Gradient Filter Box and inspect for arcing. If there is any arcing, replace the Gradient Filter (46-320232G1). At this time perform a check for loose connections on the penetration panel. Tighten all connections and replace barriers and cover. See Illustration 4-15.

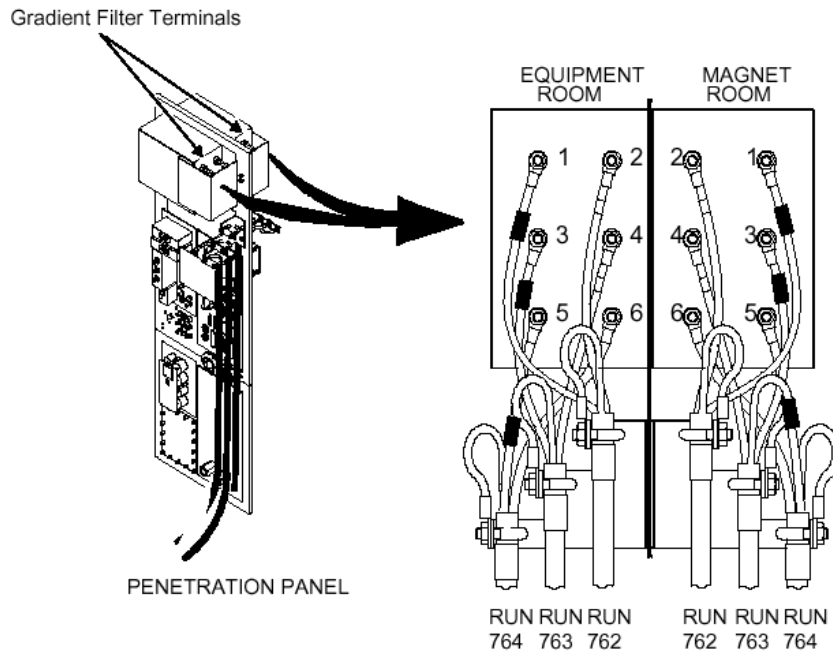

**PENETRATION PANEL GRADIENT FILTER BOX CONNECTIONS**  
 ILLUSTRATION 4-15

4-3 CHECK GRADIENT CABLE CONNECTIONS AND SUPPORT (continued)

Gradient Output Cables Terminal Block

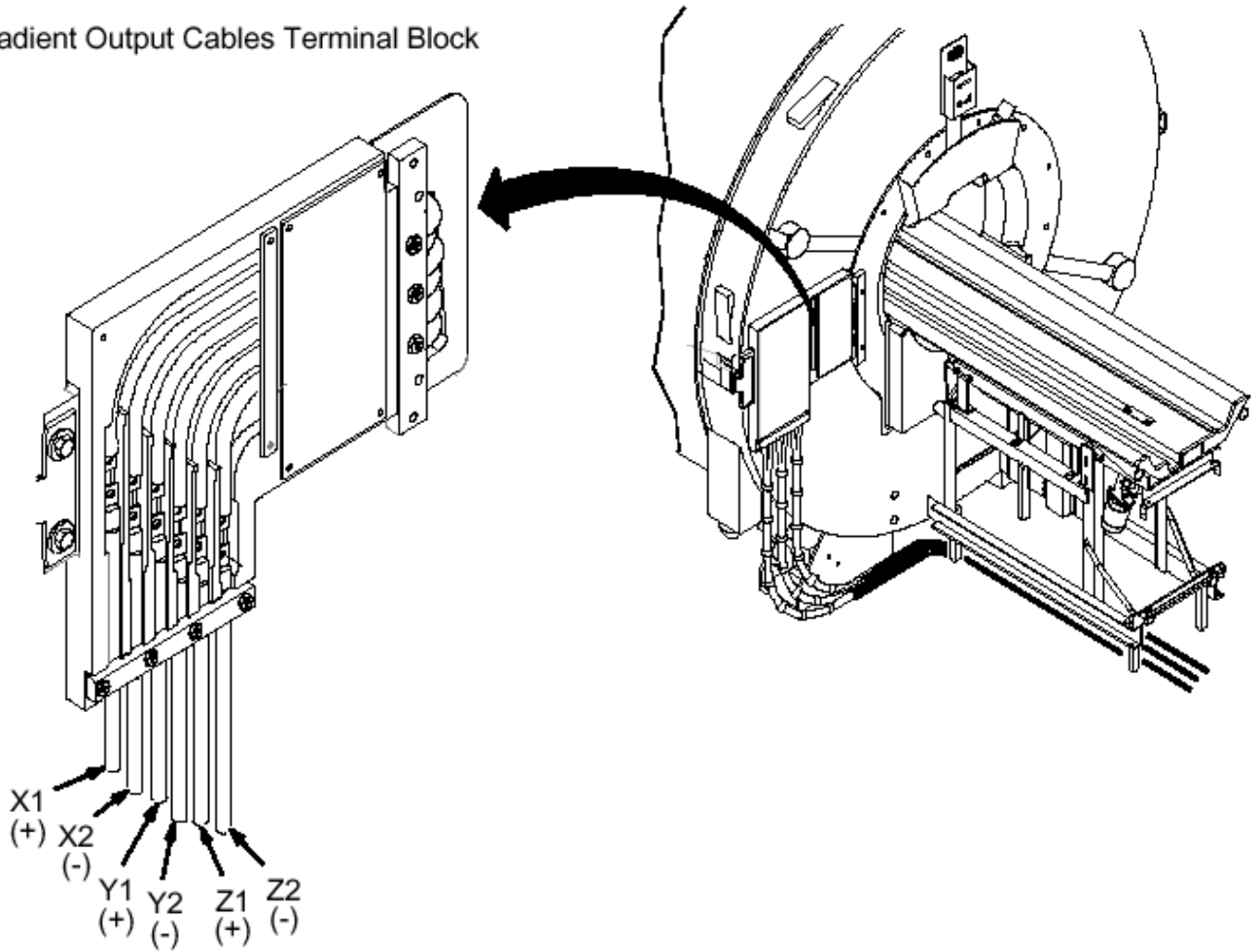

GRADIENT CABLE TERMINAL BLOCK  
ILLUSTRATION 4-16

**4-3 CHECK GRADIENT CABLE CONNECTIONS AND SUPPORT (continued)**  
**SGD HI-Slew Gradient Cabinet**

1. Power down the SGD Cabinet by turning off the Main Breakers and Auxiliary Breakers on the Front Panel of **both** the Mini-GRAM Power Supply and the Gradient Power Module Power Supply. See Illustration 4-17.

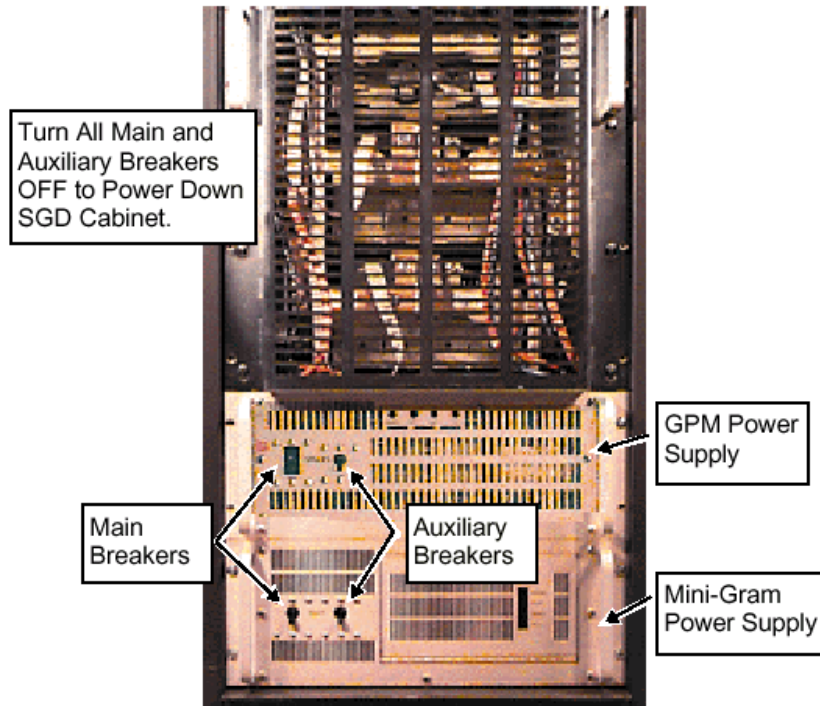

**SGD HI-SLEW CABINET—LOWER HALF (FRONT COVER REMOVED)**  
 ILLUSTRATION 4-17

2. Turn off the SGD Cabinet Breaker at the Power Distribution Unit. Lock out the Breaker and tag it.
3. After power to the SGD Cabinet has had sufficient time to dissipate, take a Digital Multimeter and set it to its highest AC voltage range.
4. Verify that all energy has dissipated by measuring incoming power to all components of the Scaleable Gradient Cabinet by following steps 5 and 6.

**4-3 CHECK GRADIENT CABLE CONNECTIONS AND SUPPORT (continued)**

5. Measure incoming power to the Mini-GRAM Power Supply as follows:
- Place the reference probe (black) on the SGD Cabinet Ground.
  - Locate J10. This is the 208V, 3 Phase input to the Mini-GRAM Power Supply.
  - Measure voltage at each of three 208 Volt input terminals. The meter should read 0 Volts AC at each of the three measuring points. See Illustration 4-18.

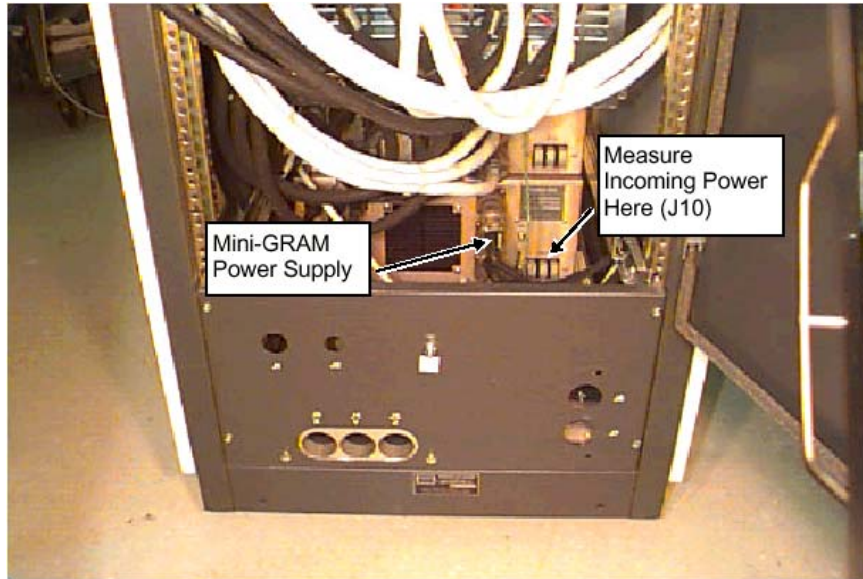

**SGD CABINET—REAR VIEW: INCOMING POWER MEASUREMENT LOCATIONS**  
ILLUSTRATION 4-18

**4-3 CHECK GRADIENT CABLE CONNECTIONS AND SUPPORT (continued)**

6. Measure voltage at the GPM Power Supply as follows:
- Place the reference probe (black) on the SGD Cabinet Ground.
  - Locate J-10. This is the 208V, 3 Phase input to the GPM Power Supply.
  - Place the red probe on each of three 208 Volt input terminals: L1, L2, and L3. The meter should
  - read 0 Volts AC at each of the three measuring points. See Illustration 4-19.

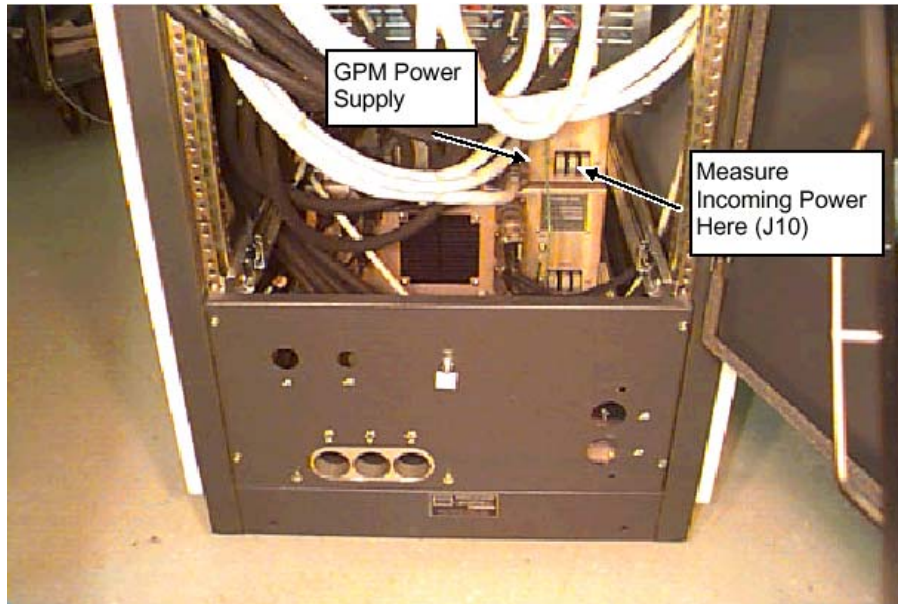

**SGD CABINET—REAR VIEW: INCOMING POWER MEASUREMENT LOCATIONS**  
ILLUSTRATION 4-19

**4-3 CHECK GRADIENT CABLE CONNECTIONS AND SUPPORT (continued)**

7. Verify gradient cable connections are secure at Mini-GRAM Amplifiers, GPM Power Supply, Cable Interface, both sides of Penetration Panel, and gradient cable terminal strip at rear pedestal. See Illustration 4-20 for overall diagram of gradient cable connections. See Illustrations 4-20 through 4-22 for connection details.
8. Verify that the gradient cable bundle coming from the Body Coil is well supported/ty-wrapped. See Illustration 4-20.

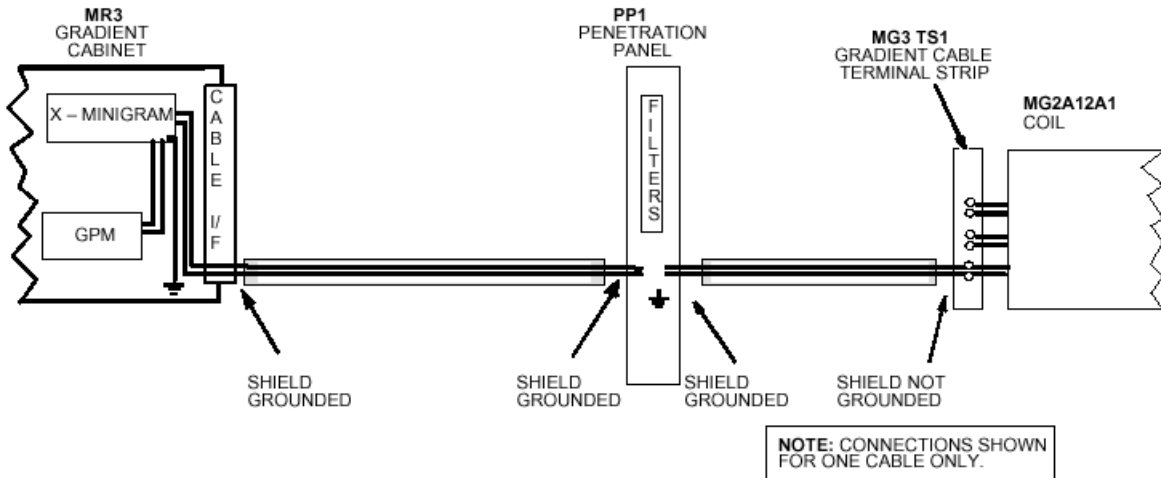

**GRADIENT CABLE CONNECTIONS FOR SGD HI-SLEW GRADIENT CABINET**  
 ILLUSTRATION 4-20

9. On the Control Room side of the Penetration Panel, remove the cover of the Gradient Filter Box and inspect for arcing. If there is any arcing, replace the Gradient Filter (46-320232G1). At this time perform a check for loose connections on the penetration panel. Tighten all connections and replace barriers and cover. See Illustration 4-21.

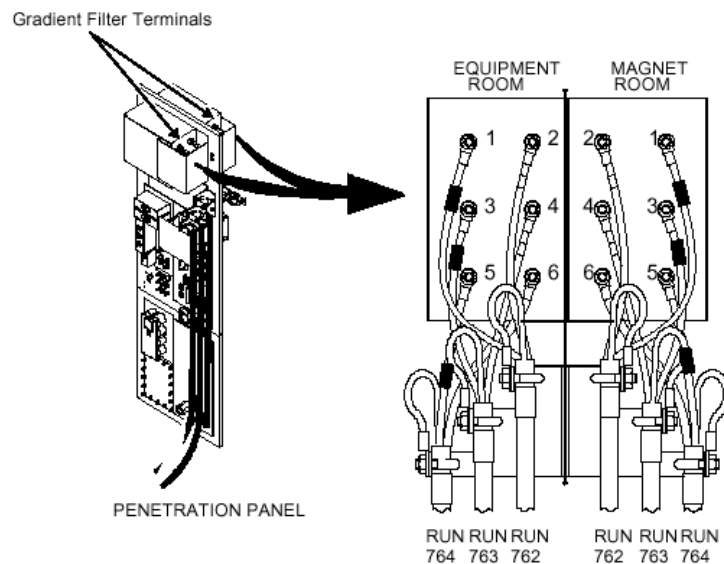

**PENETRATION PANEL GRADIENT FILTER BOX CONNECTIONS**  
 ILLUSTRATION 4-21

4-3 CHECK GRADIENT CABLE CONNECTIONS AND SUPPORT (continued)

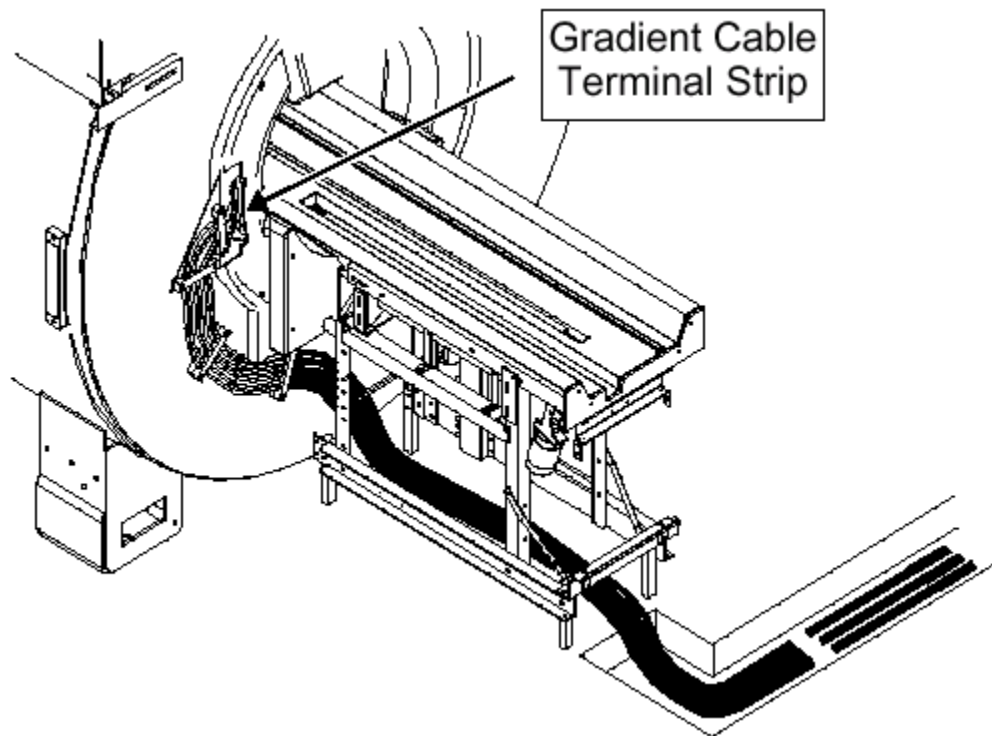

GRADIENT CABLE TERMINAL BLOCK  
ILLUSTRATION 4-22

**4-3 CHECK GRADIENT CABLE CONNECTIONS AND SUPPORT (continued)**  
**SGD Base (SR20)**



**FATAL ELECTRIC SHOCK HAZARD! TO PREVENT FATAL ELECTRIC SHOCK, DISCONNECT POWER FROM THE PDU BEFORE YOU PERFORM THE FOLLOWING PROCEDURES. PERFORM LOCKOUT/TAGOUT PROCEDURE PER GE OSHA LOCKOUT/TAGOUT REQUIREMENTS 29 CFR 1910.147. DO THIS BY SECURING THE PDU CIRCUIT BREAKER FOR THE SCALEABLE GRADIENT CABINET.**

1. Turn off the SGD Cabinet Breaker at the Power Distribution Unit. Lock out the Breaker and tag it.
2. After power to the SGD Cabinet has had sufficient time to dissipate, take a Digital Multimeter and set it to its highest AC voltage range.
3. Verify that all energy has dissipated by measuring incoming power to all components of the Scaleable Gradient Cabinet.
  - Place the reference probe (black) on the SGD Cabinet Ground.
  - Locate L1, L2, and L3. These are the 208V, 3 Phase inputs to the SGD Base SR-20 Cabinet.
4. Measure voltage at each of three 208 volt input terminals. The meter should read 0 volts AC at each of the three measuring points. See Illustration 4-23.

Measure Incoming Power Here (L1, L2, L3)

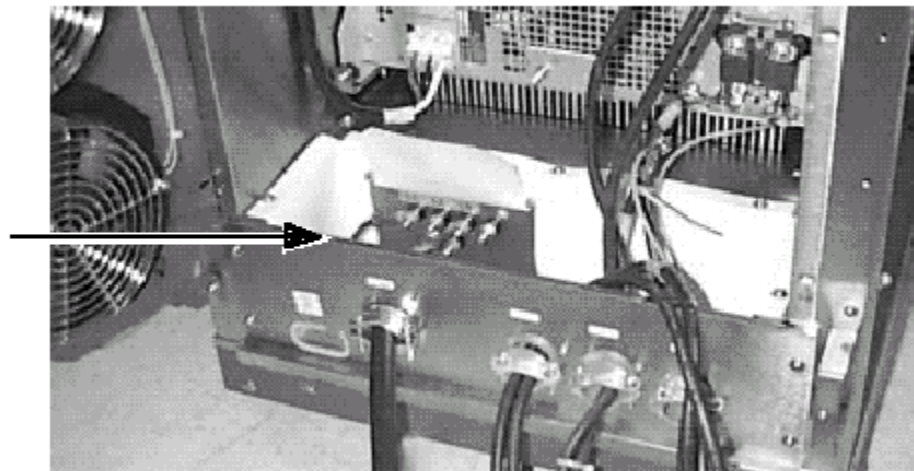

**POWER MEASUREMENT LOCATIONS**

ILLUSTRATION 4-23

**4-3 CHECK GRADIENT CABLE CONNECTIONS AND SUPPORT (continued)**

- Verify gradient cable connections are secure at the Gradient Amplifiers, both sides of Penetration Panel, and gradient cable terminal strip at rear pedestal. See Illustration 4-24 for overall diagram of gradient cable connections. See Illustrations 4-24 through 4-26 for connection details.

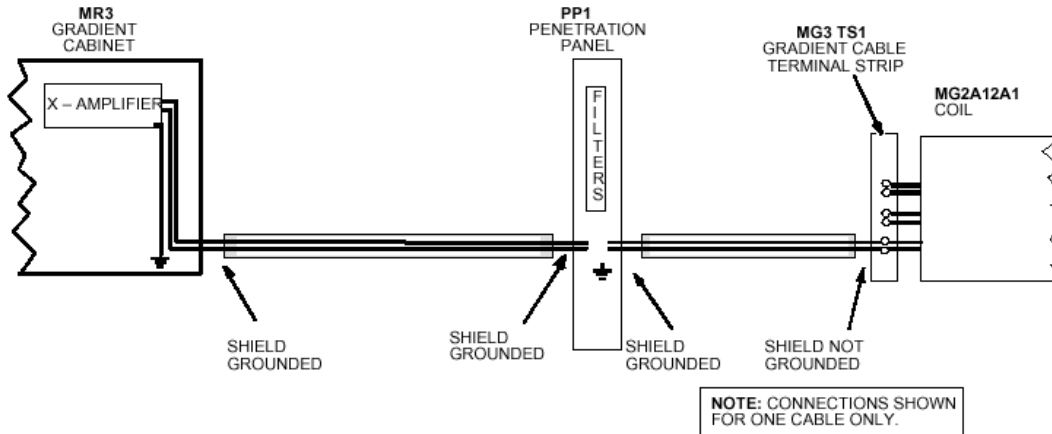

**GRADIENT CABLE CONNECTIONS**  
 ILLUSTRATION 4-24

- On the Control Room side of the Penetration Panel, remove the cover of the Gradient Filter Box and inspect for arcing. If there is any arcing, replace the Gradient Filter (46-320232G1). At this time perform a check for loose connections on the penetration panel. Tighten all connections and replace barriers and cover. See Illustration 4-25.

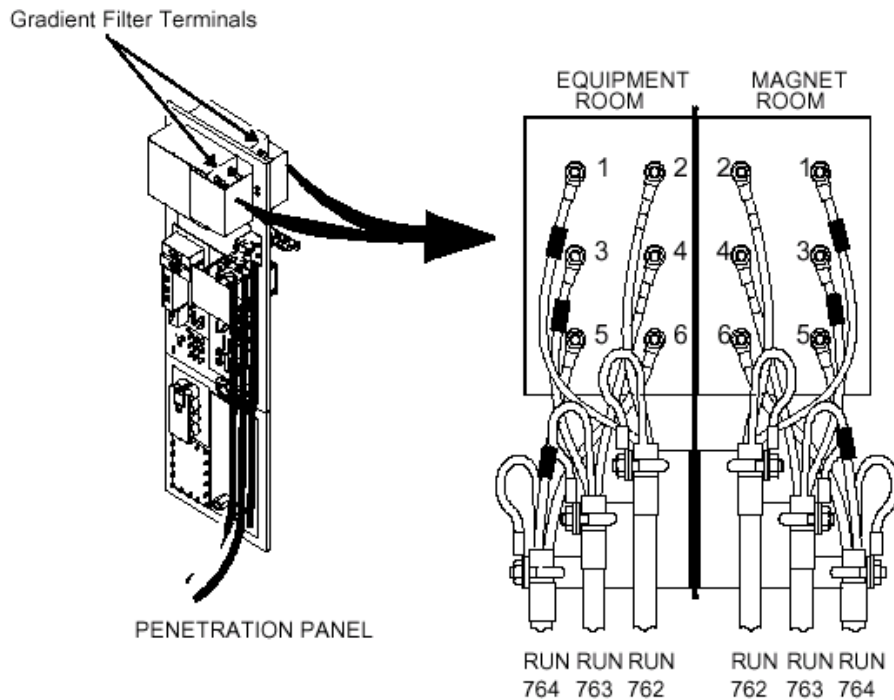

**PENETRATION PANEL GRADIENT FILTER BOX CONNECTIONS**  
 ILLUSTRATION 4-25

4-3 CHECK GRADIENT CABLE CONNECTIONS AND SUPPORT (continued)

Gradient Output Cables Terminal Block

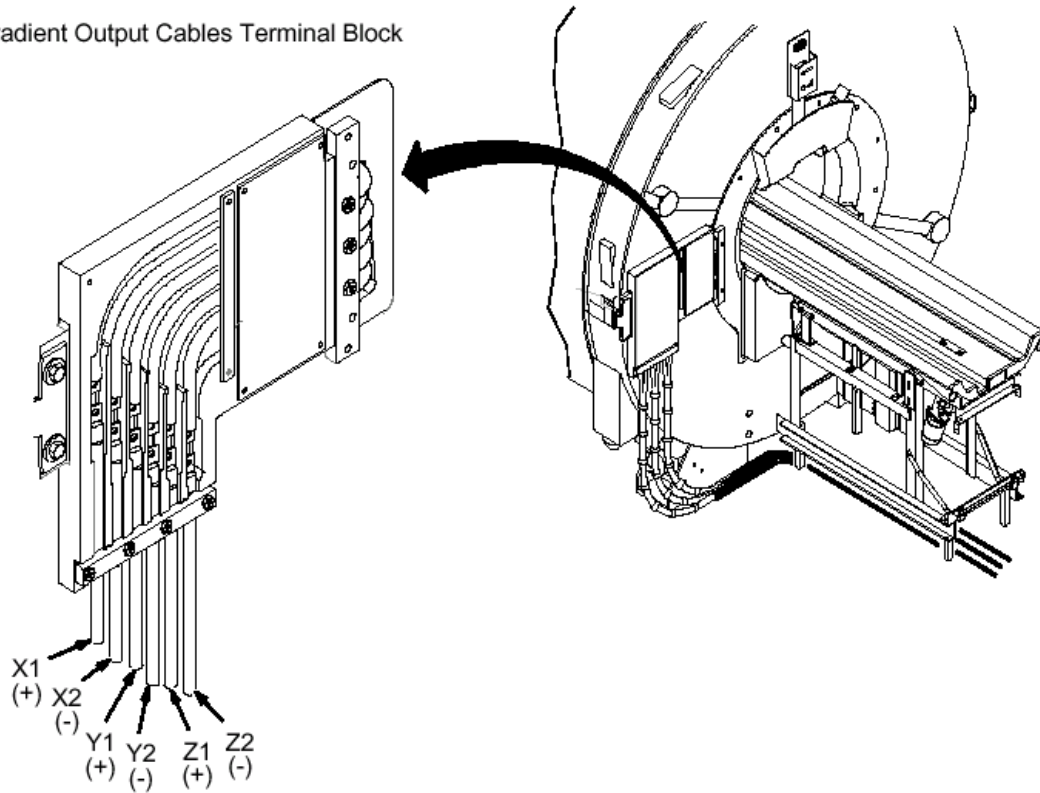

GRADIENT CABLE TERMINAL BLOCK  
ILLUSTRATION 4-26

**4-4 CHECK GRADIENT CALIBRATION**

Gradient calibration is checked using data from SPT. (Refer to Appendix E, Section E-1-2, Viewing Results and Calibration Files.)

1. Verify there is a SPT file that was run within the last month. If not, run SPT now. (Refer to APPENDIX E, SYSTEM PERFORMANCE TEST.)
2. Verify that SPT Gradcal is within specification.
3. If Gradcal is within specification, the Gradient Calibration is OK. If any of these are out of specification, schedule time to adjust them.

**4-5 CHECK FLUID LEVEL AND VALVE OF HEAT EXCHANGER FOR GRADIENT COIL COOLING**

**Lytron Heat Exchanger**

Check fluid levels (2138791) and valve of the heat exchanger.

**Noise Level**

Any abnormal sound or substantial increase in noise level since the last inspection may indicate an impending pump; fan or coolant blockage problem, which should be further, investigated.

**Leakage**

The scheduled visual check does not require removal of the top cover. However, observation of coolant on the floor surface, coming out from under the system, calls for a further check for possible leaks.

**Coolant Level**

Any significant drop in the coolant level since the previous weekly check should be investigated further. If there is no visual system leak, then the loss may be due to leakage elsewhere in the equipment.

**Pump Motor Lubrication**

After 1 year of heavy-duty service add oil annually. Use electric motor or SAE 10 oil.

**Reservoir**

Periodically inspect the fluid inside the reservoir. If cleaning is necessary, flush the reservoir with a cleaning fluid compatible with the circulating system and the cooling fluid. The cooling fluid should be replaced periodically. Build up of minerals and other contaminants occur in clean water. It is important to flush, drain and refill every 3 months.

#### 4-6 CHECK WATER CHILLER FOR GRADIENT COIL COOLING

##### Neslab Water Chiller

Clean reservoir, condensor fins, and pump strainer. Check fluid levels (2138791). Check pump motor lubrication (perform only once (1) a year). Refer to steps that follow or refer the Neslab vendor manuals located on the MR Service Methods CD Rom and/or website.

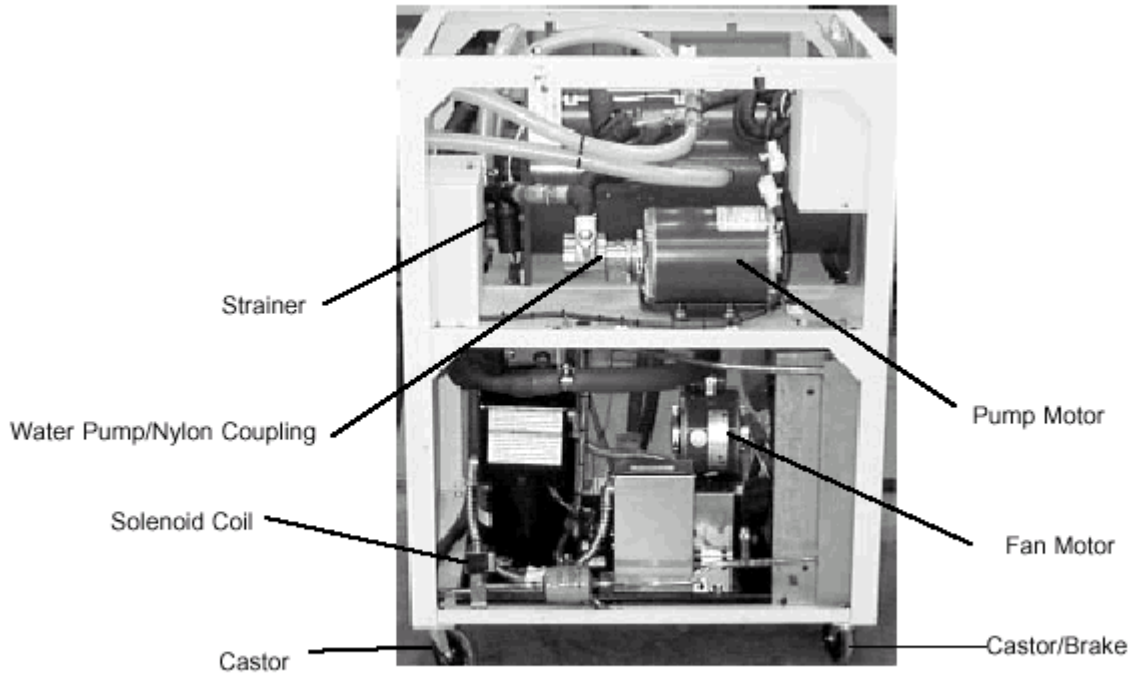

Side View

COMPONENT LOCATIONS IN NESLAB CHILLER  
ILLUSTRATION 4-27

**4-6 CHECK WATER CHILLER FOR GRADIENT COIL COOLING (continued)****Reservoir**

Periodically inspect the fluid inside the reservoir. If cleaning is necessary, flush the reservoir with a cleaning fluid compatible with the circulating system and the cooling fluid.

The cooling fluid should be replaced periodically. When operating at low temperatures, the concentration of water in the cooling fluid will increase over time, leading to a loss of cooling capacity.

Before changing the cooling fluid, raise the operating temperature of the unit to deice the cooling coils. Refer to Filling Requirements in Neslab *CFT-150, Installation, Operation & Service Manual*, (this is located on the MR Service CD Rom and the web site) for instructions on replacing the cooling fluid.

**Condenser Fins**

For proper operation, the unit needs to pull substantial amounts of air through a condenser. A build up of dust or debris on the fins of the condenser will lead to a loss of cooling capacity.

1. The lower front of the unit has a one-piece grille assembly. Gently pry the assembly off with a flathead screwdriver. Use care not to scratch the paint.
2. Periodic vacuuming of the condenser fins is necessary. The frequency of cleaning depends on the operating environment. We recommend a visual inspection of the condenser be made monthly after initial installation. After several months, the frequency of cleaning will be established.

**4-6 CHECK WATER CHILLER FOR GRADIENT COIL COOLING (continued)**

**Pump Strainer**

Units have a pump strainer. If debris is in the system, the strainer prevents the material from being drawn into the pump and damaging the pump vanes. After initial installation, the strainer may become clogged with debris and scale. Therefore, the strainer must be cleaned after the first week of installation. After this first cleaning, a biannual visual inspection is recommended.

1. Before cleaning the strainer, disconnect the power cord from the power source and place some absorbent material below the strainer assembly in case there is slight spillage.

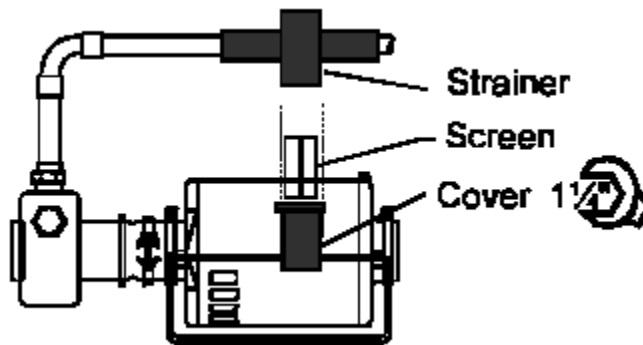

2.

**LOCATION OF STRAINER FOR NESLAB CHILLER**  
 ILLUSTRATION 4-28

2. Remove the wrapper from the unit. The strainer is located on the pump suction line. Place a cloth or sponge under the strainer cover to absorb any excess water.
3. Remove the 1 1/4" cover to access the strainer.
4. Use a toothbrush and clean the screen by rinsing it with water.
5. When the screen is clean, replace it in the strainer, tighten the cover and replace the wrapper.

**Pump Motor Lubrication**

PD pumps use sleeve type bearings with large reservoirs. Oiling instructions are generally posted on each motor. In the absence of instructions, add approximately 30 to 35 drops of SAE 20 non-detergent oil to each bearing on the following schedule (SAE 20 = 142 CS viscosity):

Duty Cycle Oiling Frequency
Continuous Once every year