

TABLE OF CONTENTS

TABLE OF CONTENTS	1
1- REPLACEMENT PROCEDURE	2
1-1 Tools and Instruments Required.....	2
1-2 Preliminary Set Up Procedure	2
1-3 GPM Power Supply Replacement Procedure.....	6
1-4 Functional Checks Required.....	6
APPENDIX A — UNIVERSAL HOIST LIFT KIT ASSEMBLY	7
A-1 ASSEMBLY PROCEDURE	7
A-1-1 Introduction.....	7
A-1-2 Tools Required	7
A-1-3 Assembly Procedural Steps	7
REVISION HISTORY	15

SGD GPM POWER SUPPLY REPLACEMENT

1- REPLACEMENT PROCEDURE

1-1 Tools and Instruments Required

Item	Description	Part Number
1.	GPM Power Supply	2154416-4
2.	Phillips-head Screwdriver	
3.	Flat blade Screwdriver	
4.	Universal Lift Hoist Kit with SGD Attachments	46-317266G4
5.	Digital Multimeter with high voltage probes	

1-2 Preliminary Set Up Procedure



FATAL ELECTRIC SHOCK HAZARD!! TO PREVENT FATAL ELECTRIC SHOCK, DISCONNECT POWER FROM THE PDU BEFORE YOU PERFORM THE FOLLOWING PROCEDURES. PERFORM LOCKOUT / TAGOUT PROCEDURE PER GE OSHA LOCKOUT / TAGOUT REQUIREMENTS 29 CFR 1910.147. DO THIS BY SECURING THE PDU CIRCUIT BREAKER FOR THE SCALEABLE GRADIENT CABINET.

1. Power down the SGD Cabinet by turning off the Main Breakers and Auxiliary Breakers on the Front Panel of **both** the Mini-GRAM Power Supply and the Gradient Power Module Power Supply. See Illustration 1-1.

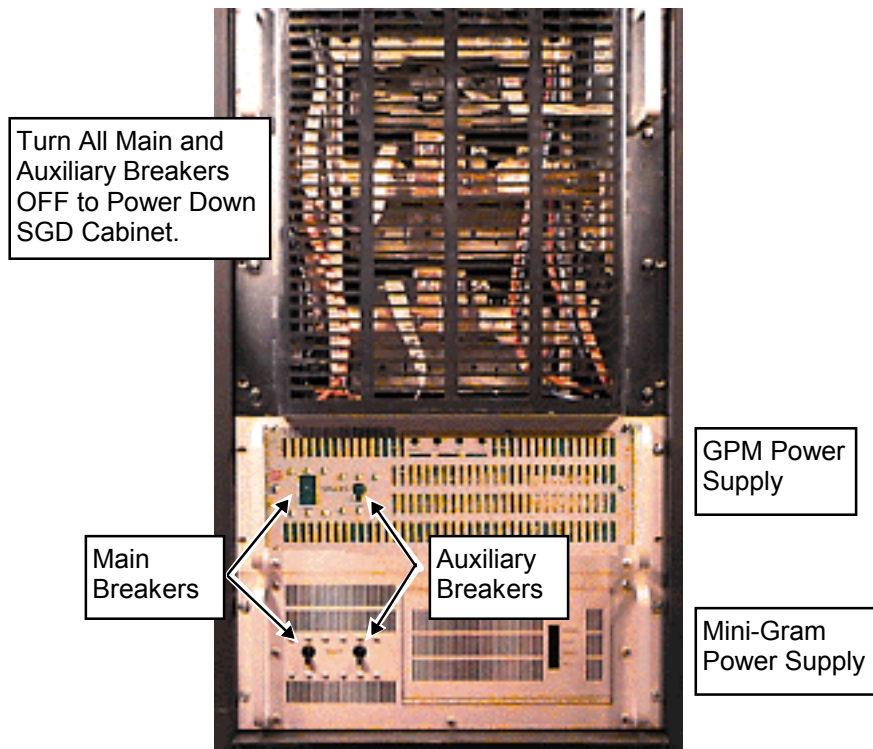

SGD HI-SLEW CABINET—LOWER HALF (FRONT COVER REMOVED)
ILLUSTRATION 1-1

2. Turn off the SGD Cabinet Breaker at the Power Distribution Unit. Lock out the Breaker and tag it.
3. After power to the SGD Cabinet has had sufficient time to dissipate, take a Digital Multimeter and set it to its highest AC voltage range.
4. Verify that all energy has been dissipated by measuring incoming power to all components of the Scaleable Gradient Cabinet by following steps 5 and 6.

5. Measure incoming power to the Mini-GRAM Power Supply as follows:

- Place the reference probe (black) on the SGD Cabinet Ground.
- Locate J10. This is the 208V, 3 Phase input to the Mini-GRAM Power Supply.
- Measure voltage at each of three 208 Volt input terminals. The meter should read 0 Volts AC at each of the three measuring points. See Illustration 1-2.

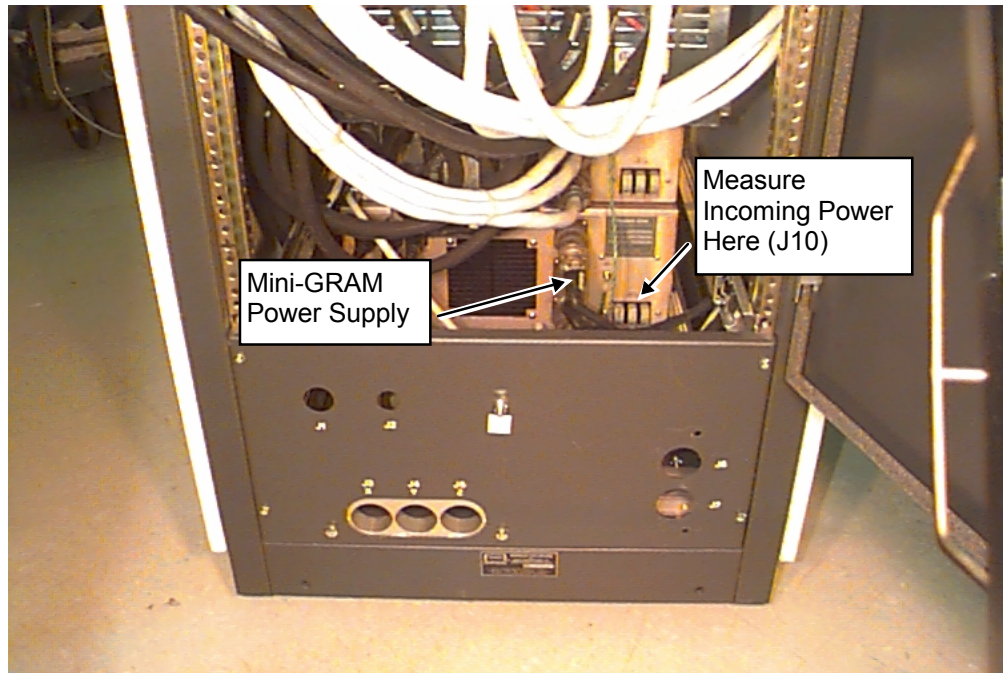

SGD CABINET—REAR VIEW: INCOMING POWER MEASUREMENT LOCATIONS
ILLUSTRATION 1-2

6. Measure voltage at the GPM Power Supply as follows:

- Place the reference probe (black) on the SGD Cabinet Ground.
- Locate J-10. This is the 208V, 3 Phase input to the GPM Power Supply.
- Place the red probe on each of three 208 Volt input terminals: L1, L2, and L3. The meter should read 0 Volts AC at each of the three measuring points. See Illustration 1-3.

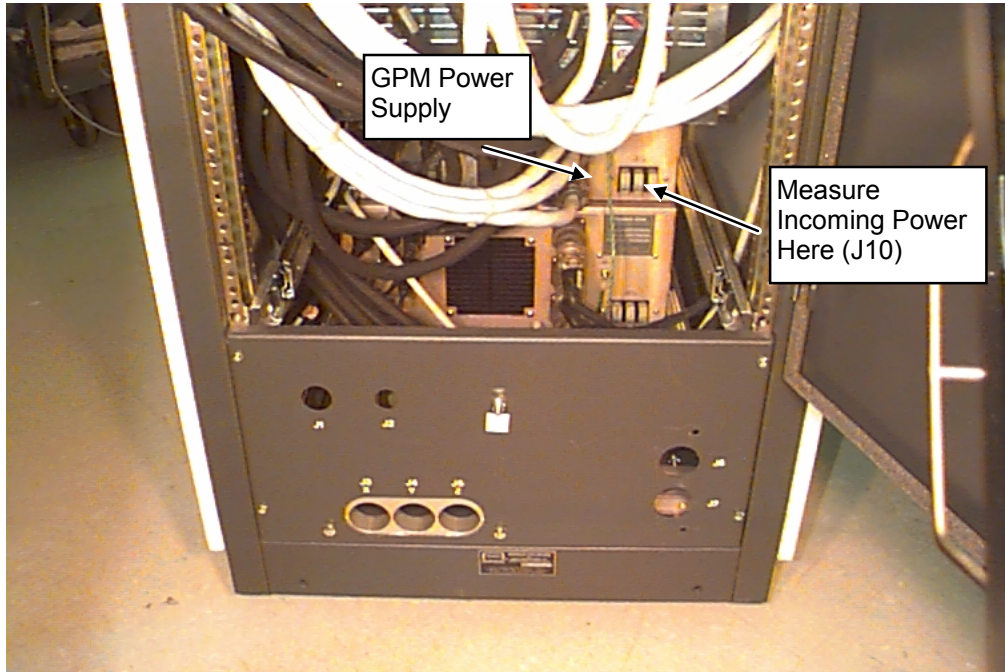

SGD CABINET—REAR VIEW: INCOMING POWER MEASUREMENT LOCATIONS
ILLUSTRATION 1-3

1-3 GPM Power Supply Replacement Procedure

1. Remove the SGD Cabinet front cover.
2. Locate the GPM Power Supply in the SGD Cabinet. See Illustration 1-4

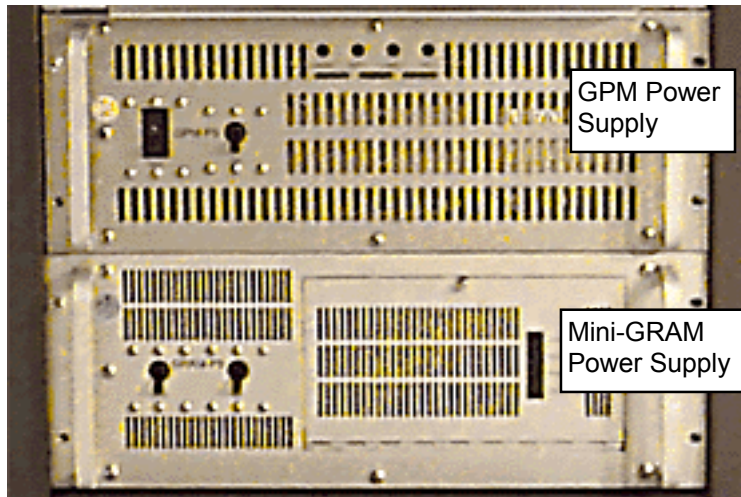

GPM AND MINI-GRAM POWER SUPPLY MODULES—FRONT VIEW
ILLUSTRATION 1-4

3. Remove all cables from the rear of the GPM Power Supply Module.
4. Pull out the GPM Power Supply Module until its slide rails latch.
5. Attach the Universal Hoist Lift Kit (see Appendix A) and follow steps 6 through 13 to disengage the GPM Power Supply from its slide rails.
6. Face the right side of the module. Slide the module part of the way out.
7. Observe that there are three Phillips-head screws securing the slide rails to the module.
8. Locate the oval-shaped hole in the outer section of the right slide rail.
9. Slide the module out so that the oval hole lines up with and exposes the screw that is closest to the rear of the module. Remove this screw and its external tooth washer.
10. Slide the module all the way out until the rail locks snap in place.
11. Remove the other two screws which also secure the slide rail to the module.
12. Repeat these steps on the opposite side of the GPM Power Supply Module.
13. Remove the GPM Power Supply Module from the SGD cabinet.
14. Reverse the order of the above steps to install a GPM Power Supply.

1-4 Functional Checks Required

No calibrations required; power up the gradient cabinet and verify the system goes to Ready.

APPENDIX A — UNIVERSAL HOIST LIFT KIT ASSEMBLY

A-1 ASSEMBLY PROCEDURE

A-1-1 Introduction

The Universal Lift Hoist is assembled from parts stored in the Universal Lift Hoist Kit. Lift attachments specially designed for the Scaleable Gradient Cabinet (SGD) are found in the outer-most compartments of the lift kit.

A-1-2 Tools Required

- Universal Lift Hoist Kit with SGD attachments, 46-317266G4
- Small hand tools including a Phillips-head screwdriver
- Two medium sized crescent wrenches

A-1-3 Assembly Procedural Steps

1. Locate the three (3) large Steel Rail sections and place them on a flat surface for assembly. See Illustration A-1.

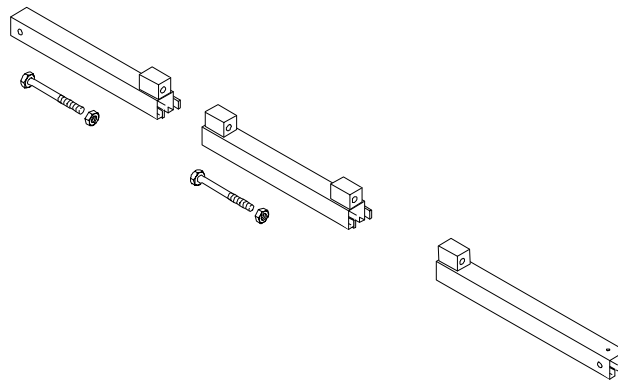

STEEL RAIL SECTIONS, HEX BOLTS, AND HEX NUTS
ILLUSTRATION A-1

2. Arrange the rail sections in the proper order (rear, center, then front) and fasten them together with 4.75" X 1/2" caps crews and hex nuts.
3. Use the crescent wrenches to tighten the cap screws.

- 4. Locate the Brass Colored Inner Rail and insert it into the Steel Rails as shown in Illustration A-2.

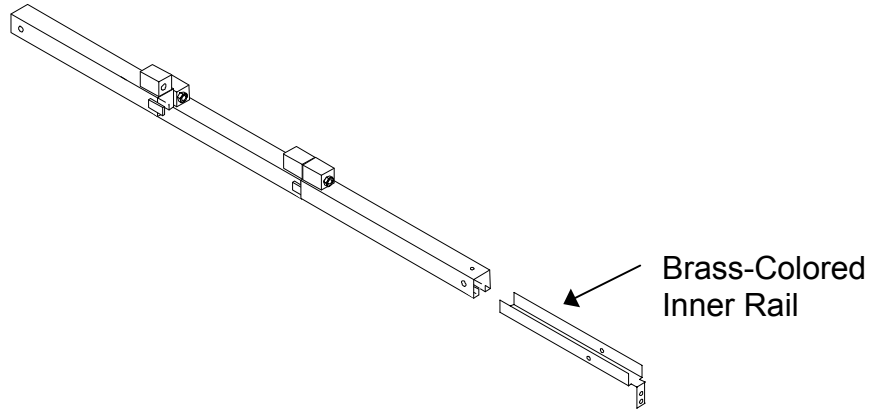

ASSEMBLED STEEL RAILS AND BRASS-COLORED INNER RAIL
ILLUSTRATION A-2

- 5. Insert the Brass Colored Inner Rail into the open end of the rear rail section.
- 6. Locate one of two (2) locking pins in the lift kit. Insert one locking pin into the hole near the open end of the rear rail section. This locking pin secures the Brass Colored Inner Rail to the outer Steel Rail. See Illustration A-3.

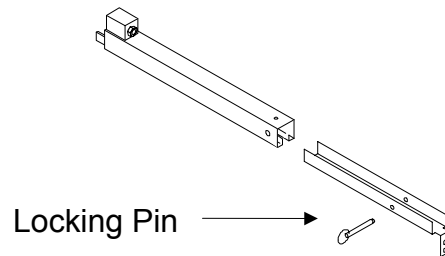

REAR STEEL RAIL, LOCKING PIN, AND BRASS-COLORED INNER RAIL
ILLUSTRATION A-3

7. Place the Steel Rail assembly on top of the Fan Enclosure at the top of the SGD Cabinet. Center the Rail Assembly on the top of the enclosure. See Illustration A-4.

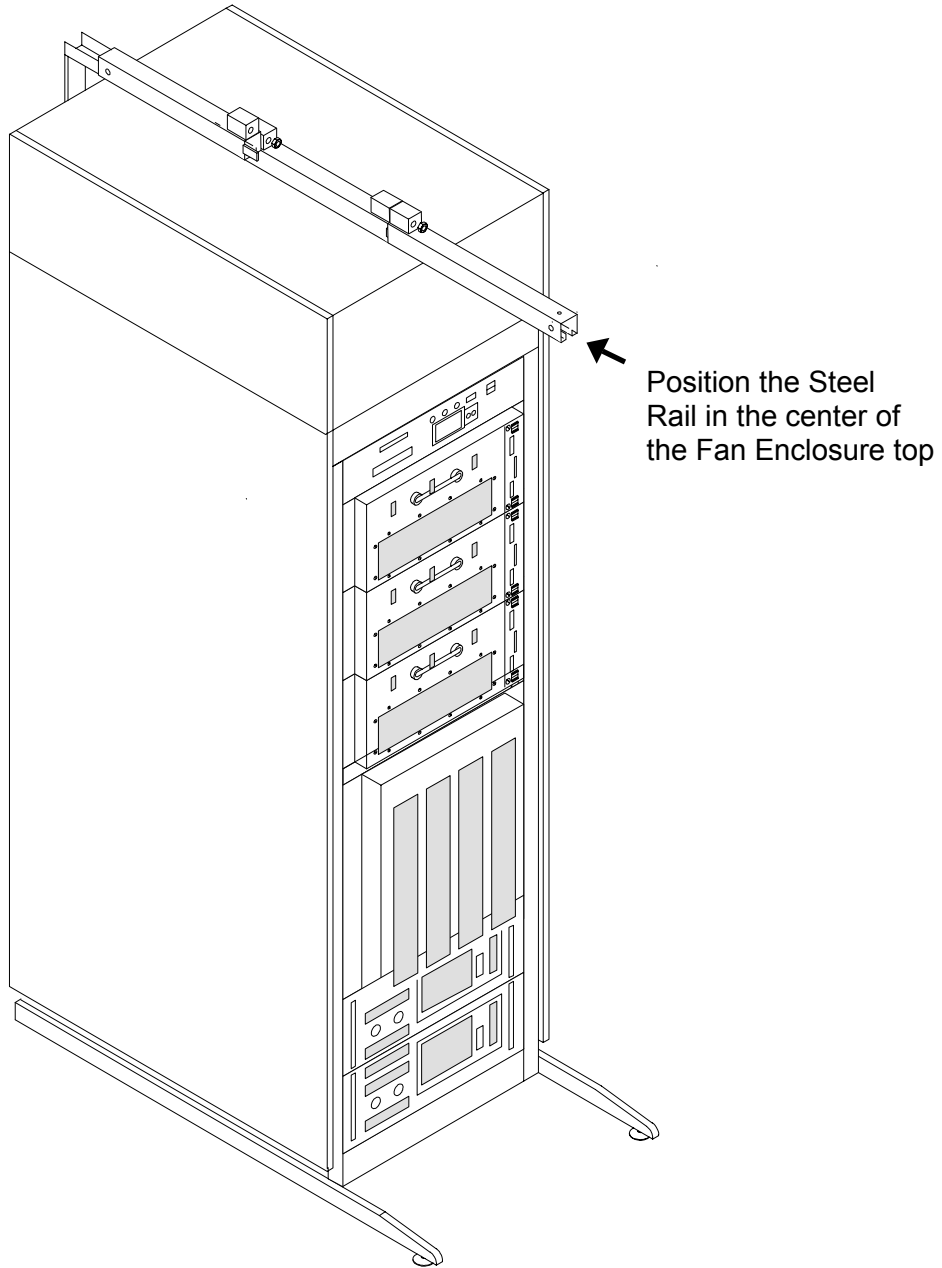

POSITIONING OF THE STEEL RAIL ASSEMBLY
ILLUSTRATION A-4

8. Locate the Brass Colored J-shaped Bracket in the Lift Kit. See Illustration A-5.

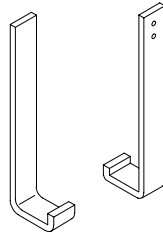

J-SHAPED BRACKET
ILLUSTRATION A-5

9. Open the rear door of the SGD Cabinet. Observe how the J-shaped Bracket fits into the rear door frame. See Illustration 1-6.

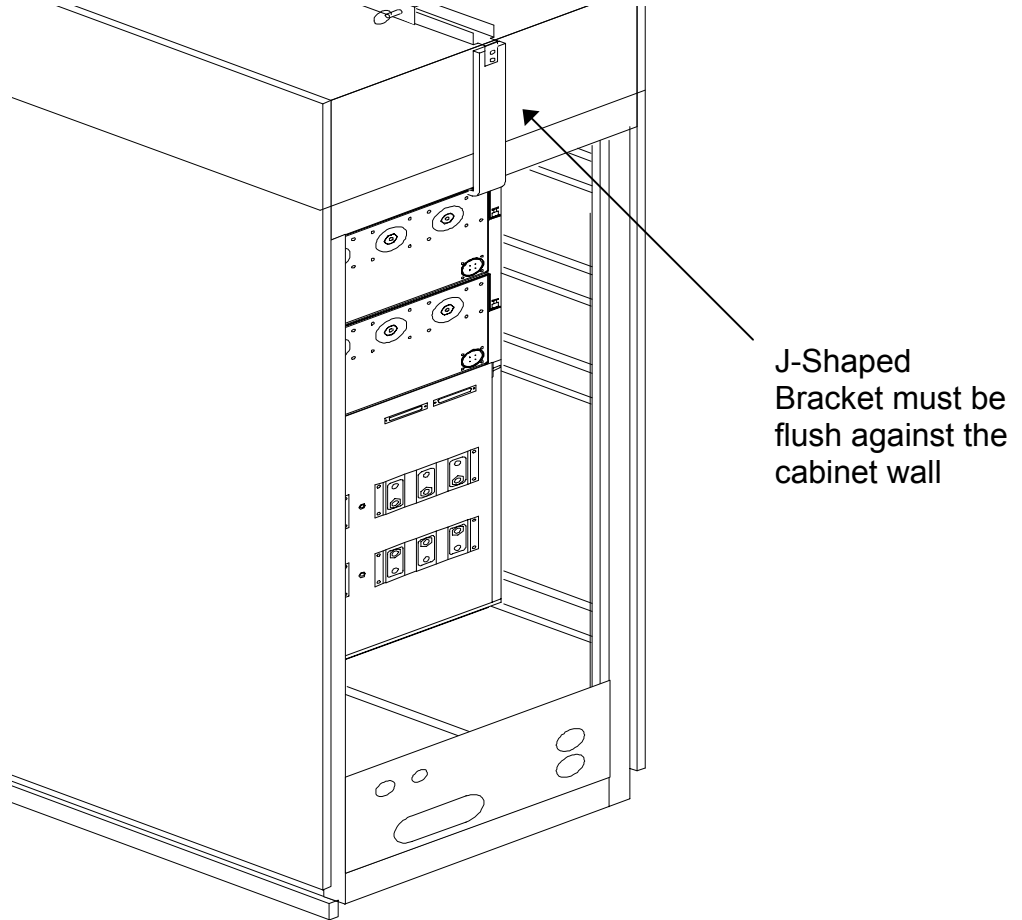

POSITIONING OF THE J-SHAPED BRACKET
ILLUSTRATION A-6

10. Slide the Rail Assembly toward the front of the SGD Cabinet. Maintain its centered position.

11. Attach the J-shaped Bracket to the Brass Colored Inner Rail so that the J-shaped Bracket is flush against the rear panel of the Fan Enclosure. Use the flat Phillips-head screws to secure the J-shaped Bracket to the Brass Colored Inner Rail. See Illustration A-7.

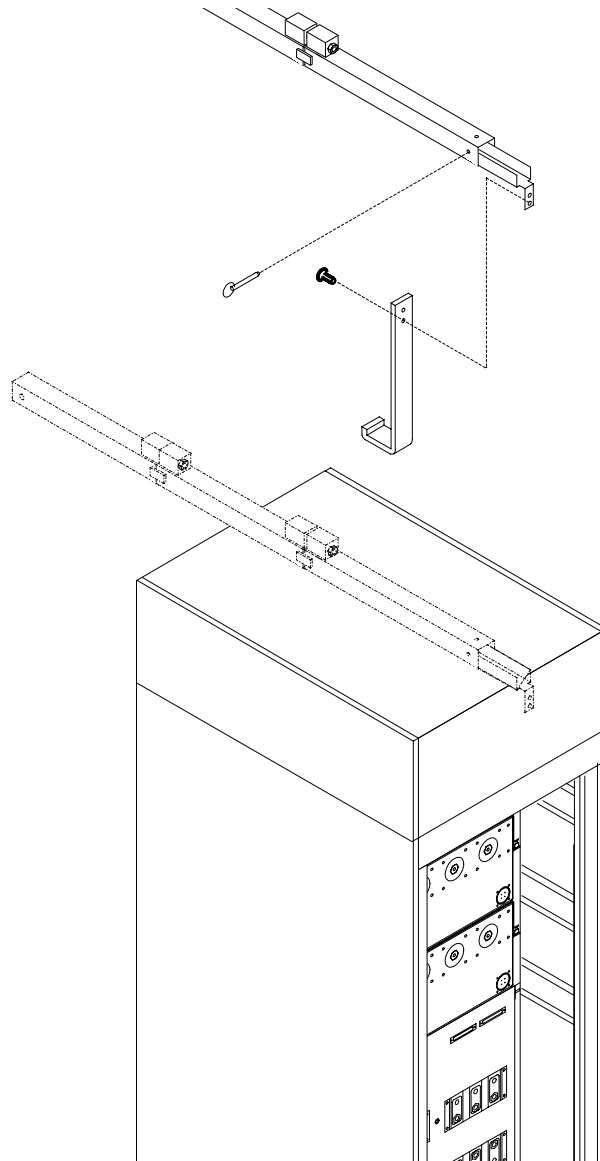

**CONNECTION OF THE J-SHAPED BRACKET TO THE STEEL RAIL ASSEMBLY
ILLUSTRATION A-7**

12. Once the J-Shaped Bracket is secured to the cabinet and the Steel Rail, attach the Saddle Bracket to the top of the Fan Enclosure. The screw holes are located at the front end of the Fan Enclosure. The Saddle Bracket prevents the Steel Rail from sliding from center position. See Illustration A-8.

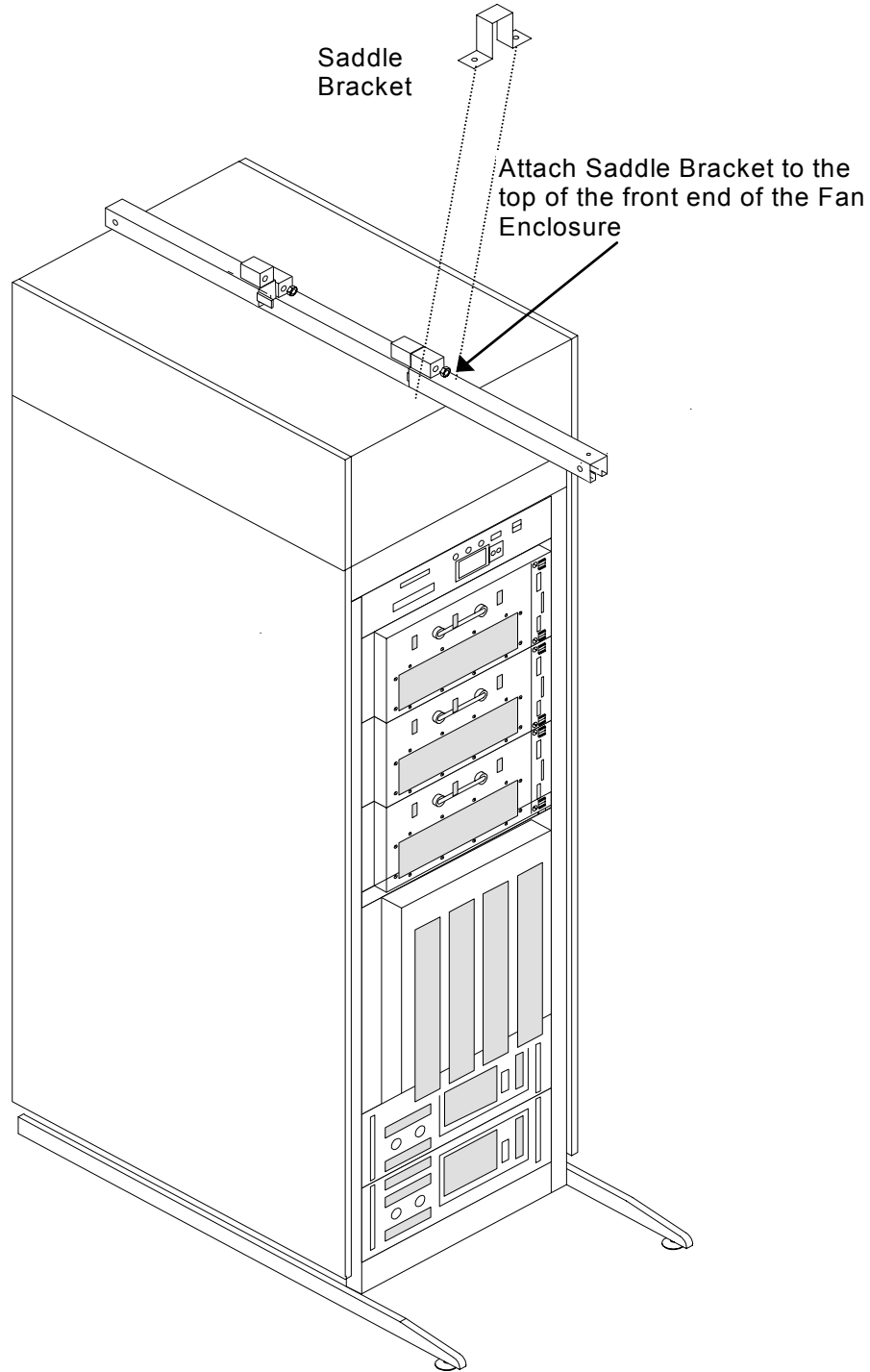

POSITIONING AND ATTACHMENT OF THE SADDLE BRACKET
ILLUSTRATION A-8

13. Locate the Hoist Assembly in the Lift Kit. See Illustration A-9.

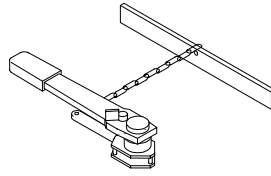

HOIST ASSEMBLY
ILLUSTRATION A-9

14. Insert the Hoist Assembly into the open end of the front rail. Insert a locking pin into the holes near the front edge of the front rail. This locking pin prevents the Hoist Assembly from sliding out of the rails. See Illustration A-10.

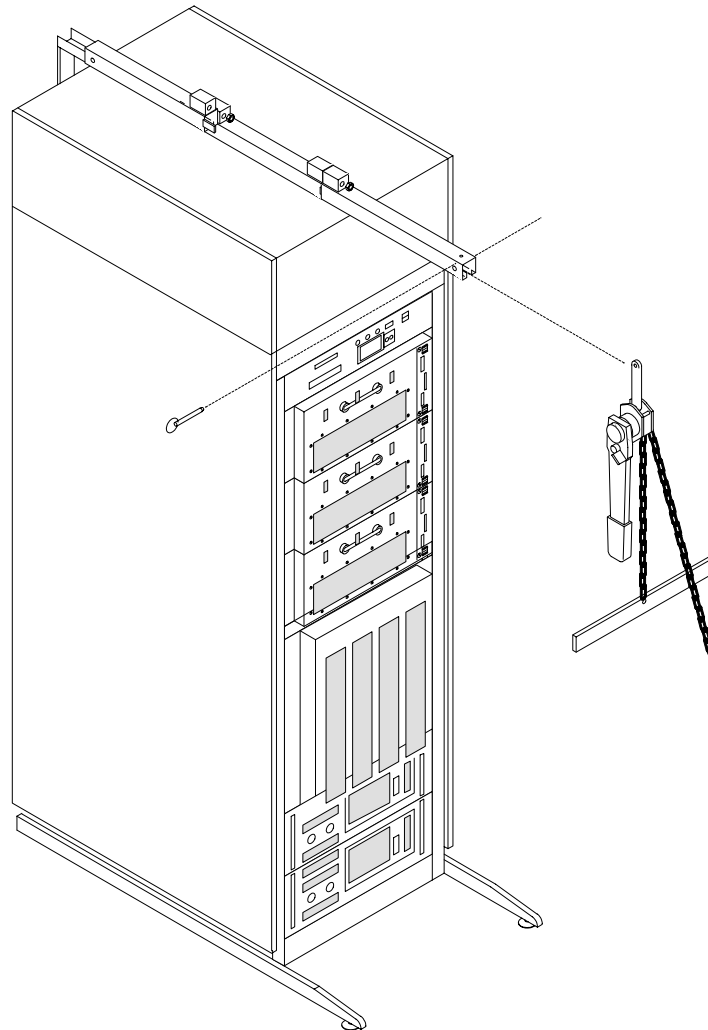

PLACEMENT OF HOIST ASSEMBLY INTO FRONT END OF STEEL RAIL ASSEMBLY
ILLUSTRATION A-10

15. Select the appropriate lift-brackets cabinet and attach them to the Hoist Assembly. The Universal Lift Hoist is now ready for operation. Illustration A-11 shows the Universal Lift Hoist being used to remove a Mini-GRAM Module from an SGD Cabinet.

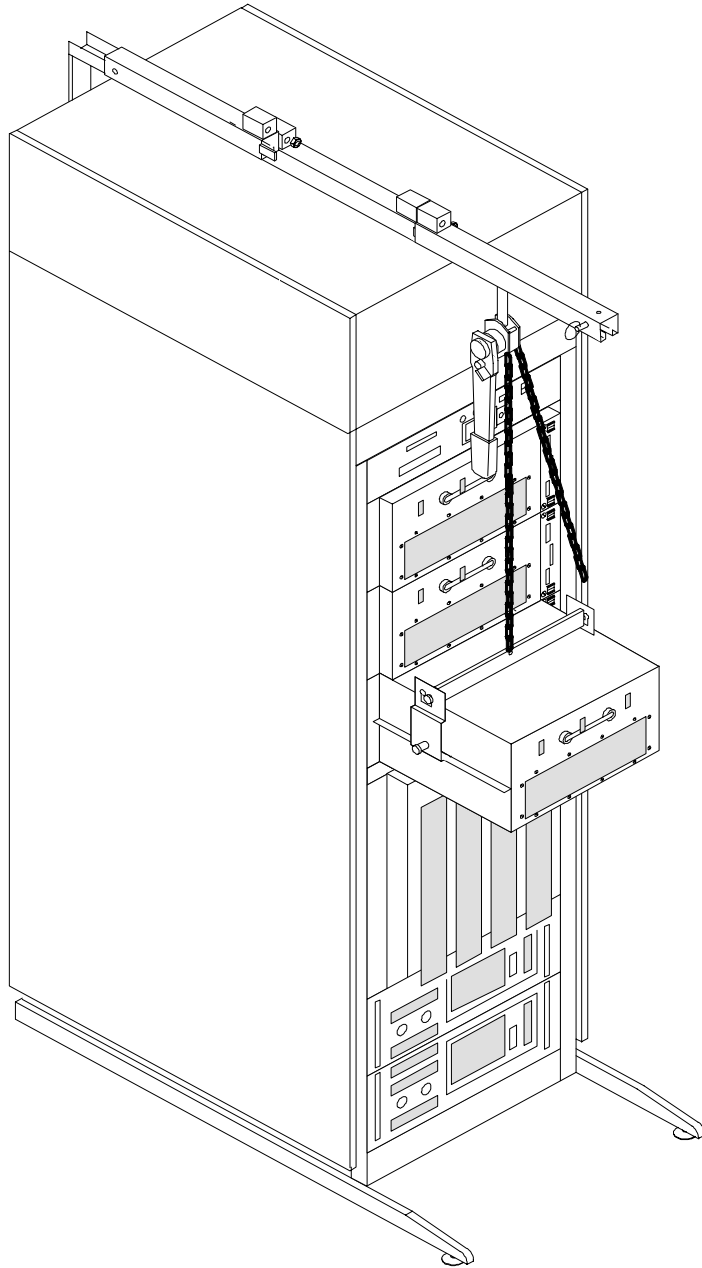

USING THE UNIVERSAL LIFT HOIST TO REMOVE A MINI-GRAM MODULE
ILLUSTRATION A-11

REVISION HISTORY

REV	DATE	AUTHOR	PRIMARY REASONS FOR CHANGE
A	Aug 11, 1997 Sep 6, 1997	F. Fiore F. Fiore	Initial draft of document completed Enter original draft in MR template for Microsoft Word documents.
B	Sep 15, 1997	F. Fiore	Incorporate illustrations and call outs
C	Sep 23, 1997	F. Fiore	Add Lock out Tag out
0	Oct 3, 1997	F. Fiore	Initial Release for SGD production
1	December 17, 1999	K. Keshena	Added Appendix A explaining the use of the Universal Hoist Lift Kit Assembly.