

## TABLE OF CONTENTS

<b>TABLE OF CONTENTS</b> .....	<b>1</b>
<b>1- REPLACEMENT PROCEDURE</b> .....	<b>2</b>
1-1 Tools and Instruments Required.....	2
1-2 Preliminary Set Up Procedure.....	3
1-3 Removal of Air Duct .....	6
1-4 Fan Removal/Replacement Procedure Steps .....	7
1-5 Functional Tests Required .....	10
1-6 Reinstallation Of Air Duct.....	10
<b>REVISION HISTORY</b> .....	<b>12</b>

## 1- REPLACEMENT PROCEDURE

### Manpower Requirements

2 (two) people are needed to lift fan

- Total Fan Assembly Weight: 114 lbs.
- Total Fan Motor/Blower Weight: 48 lbs.

### 1-1 Tools and Instruments Required

Item	Description	Part Number
1.	Fan Assembly (Motor & Turbine Only)	FRU # 2181131
2.	Ladder	
3.	2- Phillips-head screwdriver (Standard & small sizes)	
4.	11/32" or 9mm socket wrench	
5.	1 pair of Gloves	
6.	Hammer	
7.	1 large standard screwdriver	
8.	1 Razor knife	
9.	1 medium flat head screwdriver	
10.	5/16" Wrench	
11.	Duct Tape	
12.	Ty-wrap cutters	
13.	1 Ty-wrap	

## 1-2 Preliminary Set Up Procedure



**FATAL ELECTRIC SHOCK HAZARD!! TO PREVENT FATAL ELECTRIC SHOCK, DISCONNECT POWER FROM THE PDU BEFORE YOU PERFORM THE FOLLOWING PROCEDURES. PERFORM LOCKOUT / TAGOUT PROCEDURE PER GE OSHA LOCKOUT / TAGOUT REQUIREMENTS LISTED IN THE *FIELD SERVICE EHS MANUAL & TRAINING 2000 P/N 2135387-200*.**

1. Power down the system according to the directions posted in the equipment room.
2. Then power down SGD Cabinet by turning off the Main Breakers and Auxiliary Breakers on the Front Panel of **both** the Mini-GRAM Power Supply and the Gradient Power Module Power Supply. See Illustration 1-1.

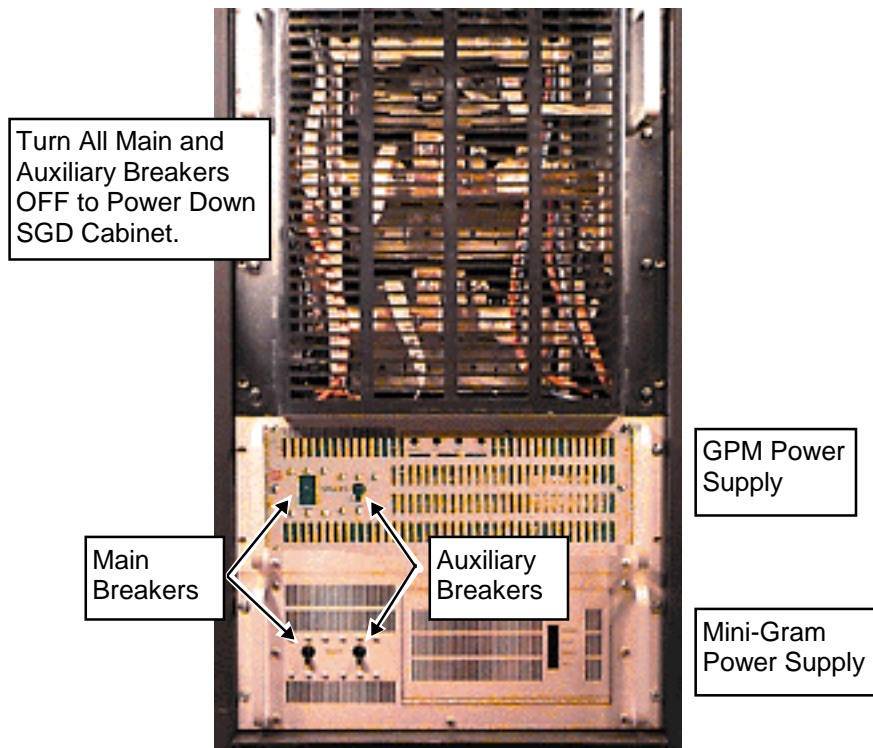

**SGD HI-SLEW CABINET—LOWER HALF (FRONT COVER REMOVED)**  
ILLUSTRATION 1-1

3. Turn off the SGD Cabinet Breaker at the Power Distribution Unit. Lock out the Breaker and tag it.
4. After power to the SGD Cabinet has been removed, take a Digital Multimeter and set it to its highest AC voltage range.

5. Verify that all energy has been dissipated. Measure incoming power to all components of the Scaleable Gradient Cabinet as directed in steps 6 and 7.
6. Measure incoming power to the Mini-GRAM Power Supply as follows:
  - Place the reference probe (black) on the SGD Cabinet Ground.
  - Locate J10. This is the 208V, 3 Phase input to the Mini-GRAM Power Supply.
  - Measure voltage at each of three 208 Volt input terminals. The meter should read 0 Volts AC at each of the three measuring points. See Illustration 1-2.

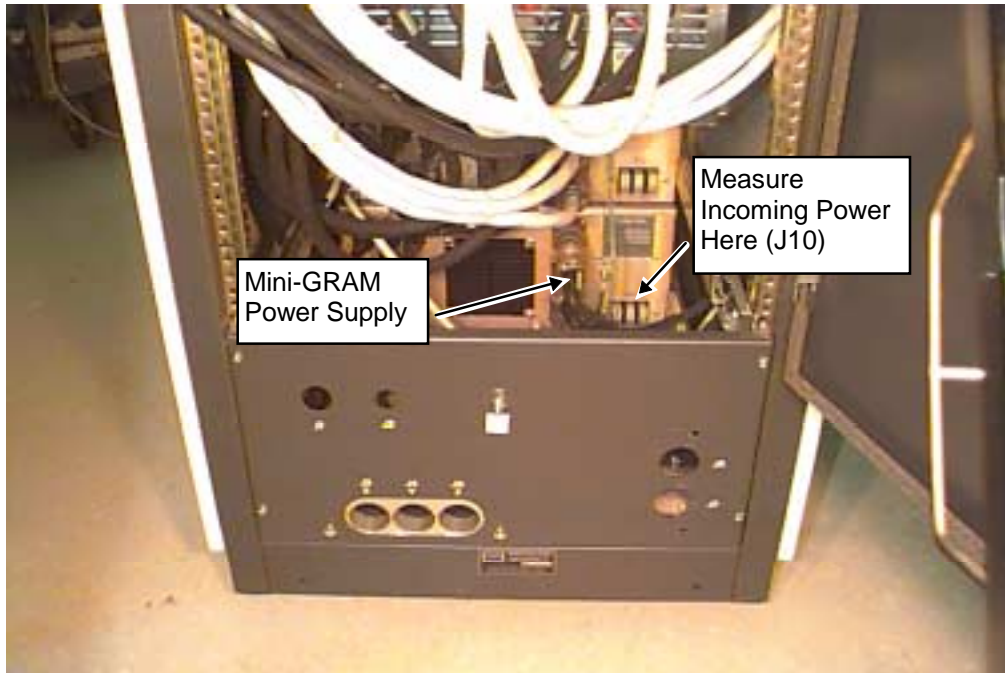

**SGD CABINET—REAR VIEW: INCOMING POWER MEASUREMENT LOCATIONS**  
ILLUSTRATION 1-2

## 1-2 Preliminary Setup Procedure (continued)

7. Measure voltage at the GPM Power Supply as follows:
- Place the reference probe (black) on the SGD Cabinet Ground.
  - Locate J-10. This is the 208V, 3 Phase input to the GPM Power Supply.
  - Place the red probe on each of three 208 Volt input terminals: L1, L2, and L3. The meter should read 0 Volts AC at each of the three measuring points. See Illustration 1-3.

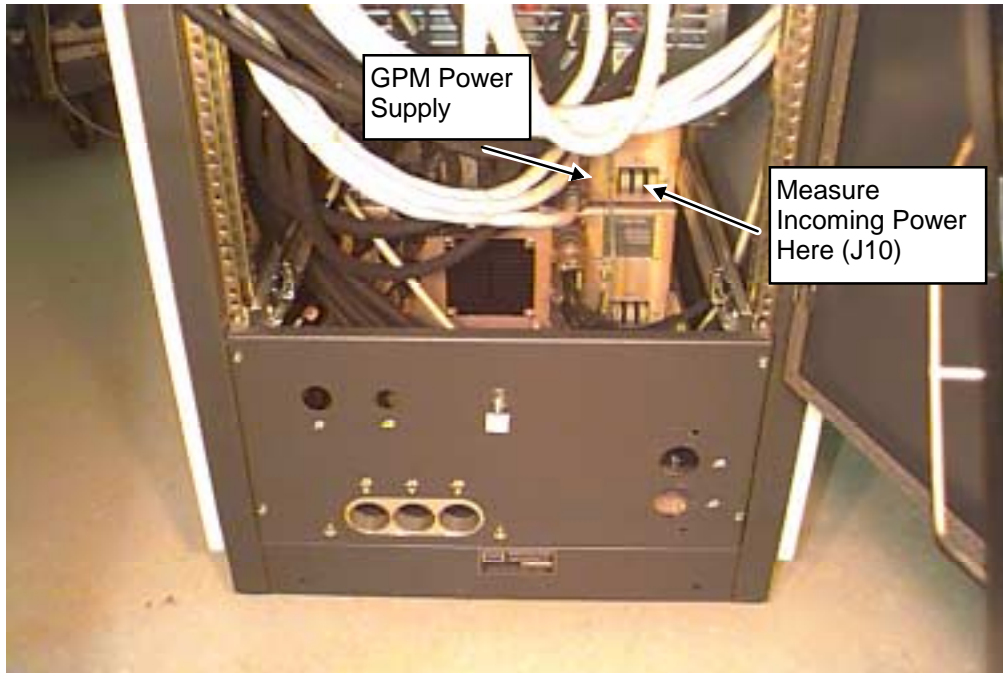

**SGD CABINET—REAR VIEW: INCOMING POWER MEASUREMENT LOCATIONS**  
ILLUSTRATION 1-3

### 1-3 Removal of Air Duct

1. Turn **OFF** the Air Handler breaker (CB6 – 40A or HVAC/AR Handler Main) in the electrical cabinet located by the side personnel door.
2. Remove foil tape from outer diameter of air duct, where duct meets front wall. See Illustration 1-4.

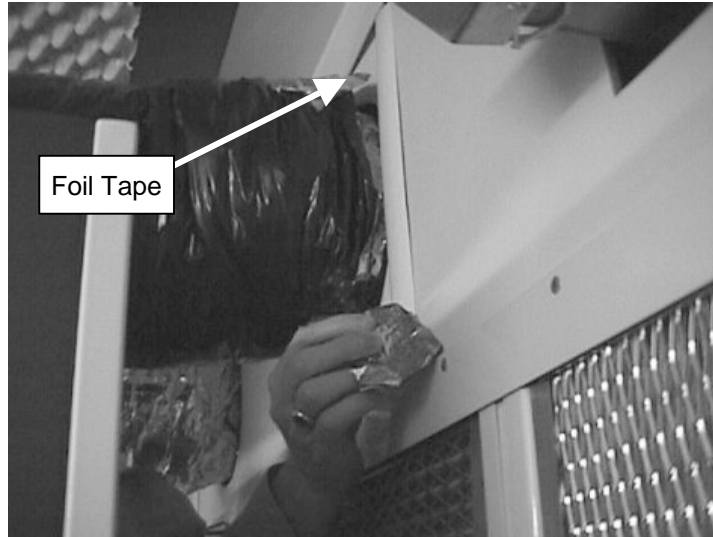

**AIR DUCT TAPE LOCATION**  
ILLUSTRATION 1-4

3. Pull back the black cover and remove more tape that secures the duct to the outer wall. See Illustration 1-5.

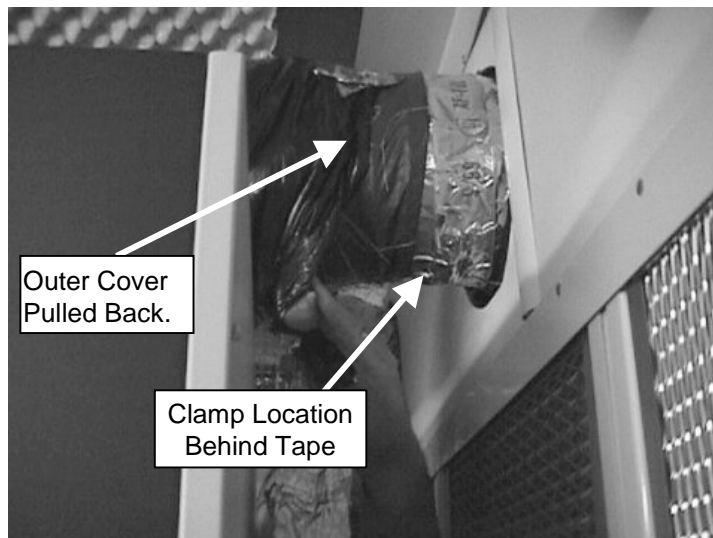

**OUTER COVER OF DUCT PULLED BACK**  
ILLUSTRATION 1-5

4. Unscrew clamp with a flat head screwdriver or a 5/16" wrench. (Pay special attention to how the clamp fits before removing it. The placement of the clamp will be crucial during the reinstallation of the duct.)

5. Pull ductwork from air handler collar. The clamp is free to fall at this point; therefore, be careful not to loose it or damage equipment by dropping it.
6. Push ductwork straight back towards the rear of trailer until it is out of the way of the SGD. The ductwork may need to be feed through the bracket hanging from the ceiling. If so, be careful not to rip or tear the ductwork. (A rip or tear requires replacement or repair of the ductwork.)
7. If the hanging bracket itself is in the way while removing the fan of the SGD remove the bracket by removing both screws with a 5/16" wrench. (Be sure not to loose the washers that are with the screws or the bracket may become loose and fall after being reinstalled.)

#### 1-4 Fan Removal/Replacement Procedure Steps

##### Note

The Fan Motor/Blower weighs 48 lbs. The procedure requires two people to remove the fan motor/blower from the cabinet.

1. Locate the Fan Enclosure at the top of the Scaleable Gradient Driver (SGD) cabinet.
2. Remove strap and two bolts of the holding plate (one in the front and one in the back). See Illustration 1-6.

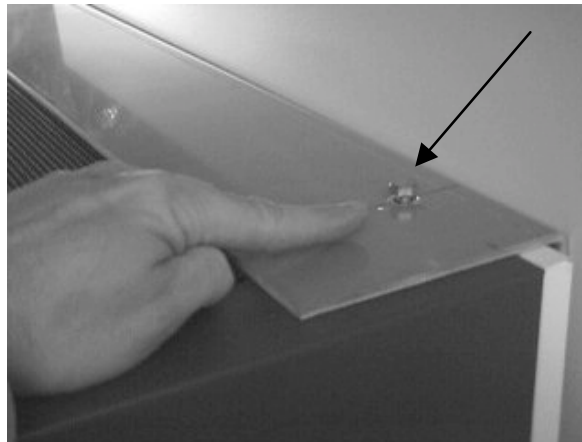

**HOLDING PLATE BETWEEN SYSTEMS AND GRADIENT CABINETS**  
ILLUSTRATION 1-6

3. Use the hammer and large standard screwdriver to remove the holding plate between the cabinets.

##### Note

In older Ellis & Watts vans, it may be necessary to unbolt the systems cabinet from the floor in the front and back to remove the fan rear side panel screw. Then push the systems cabinet forward till the panel screw is accessible for removal.

4. Remove two (2) phillips-head screws from each fan side panel.
5. Using ladder to access top of fan assembly, either tilt or remove the side covers to provide access to the top grill for removal.

6. Remove the Fan Enclosure Top Grill.
7. Locate the cable that contains the power wires leading directly to the Fan Motor. This cable is terminated with a cannon connector. See Illustration 1-7

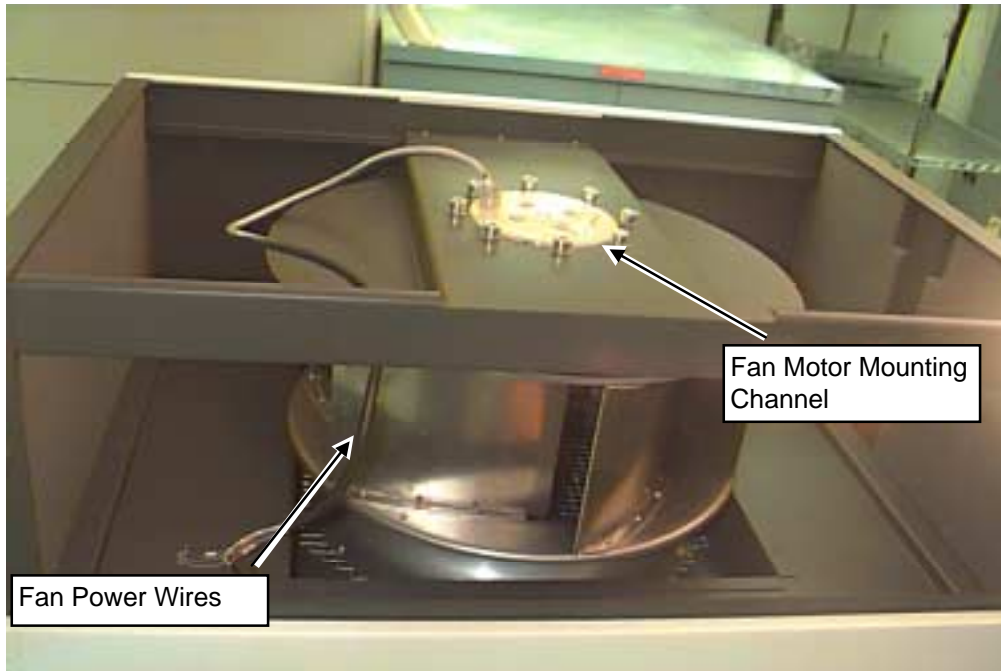

SGD CABINET FAN ENCLOSURE—INSIDE VIEW  
ILLUSTRATION 1-7

8. Locate the cannon connector from the inside of the Fan Enclosure and remove the power cable. See Illustration 1-8.

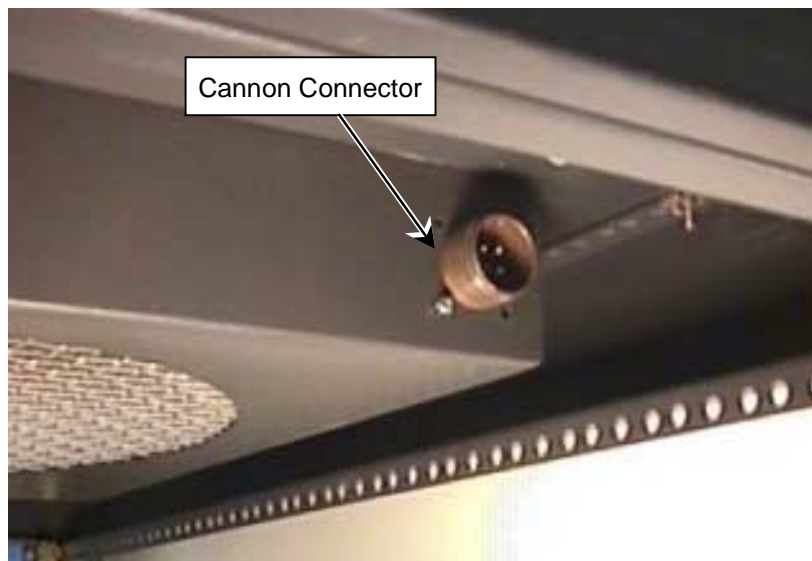

CANNON CONNECTOR LOCATION—REAR INSIDE VIEW OF CABINET  
ILLUSTRATION 1-8

- 9. Remove 4 screws, using small phillips screwdriver, holding the connector in place. See Illustration 1-8.
- 8. Remove the fan cannon connector from inside the fan motor/blower assembly. See Illustration 1-9.

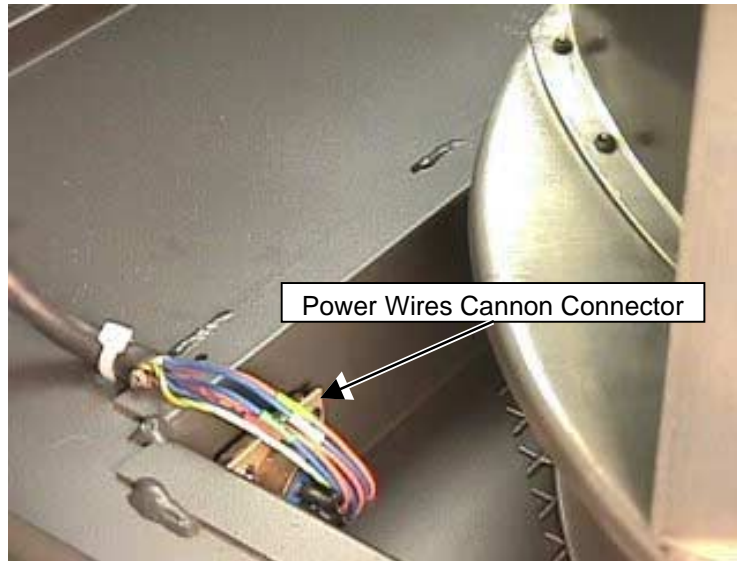

**CANNON CONNECTOR LOCATION IN FAN ASSEMBLY**  
ILLUSTRATION 1-9

- 9. Cut Ty-wraps, see Illustration 1-10.

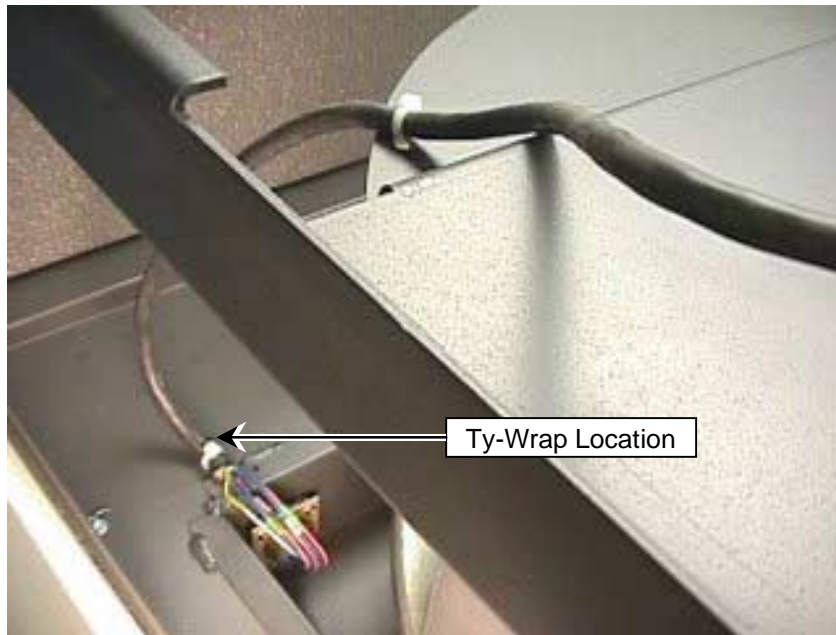

**TY-WRAP LOCATIONS**  
ILLUSTRATION 1-10

10. Remove the six (6) 11/32" or 9mm hex nuts that secure the Fan Motor Mounting Channel to the Fan Enclosure. See Illustration 1-11.

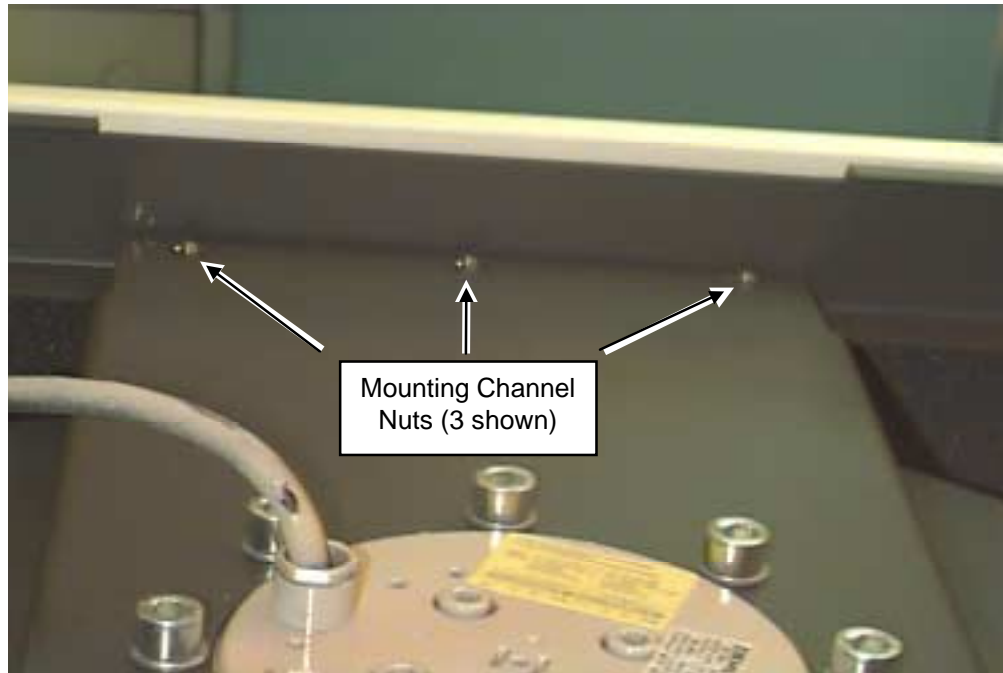

SGD CABINET FAN MOTOR MOUNTING CHANNEL  
ILLUSTRATION 1-11



**Personal injury may occur. The fan motor/blower assembly has sharp edges, wear protective gloves to avoid injury when removing from the fan assembly box.**

11. Use two people to grasp the Fan Motor Mounting bracket and lift it up and out of the Fan Enclosure.
12. Reverse the order of the above steps to install the fan replacement.

### 1-5 Functional Tests Required

Power up the SGD cabinet and verify the fan operates. The fan should create enough suction to hold the rear cabinet door closed.

### 1-6 Reinstallation Of Air Duct

1. Pull the ductwork back towards the front wall. (Be careful not to tear the ductwork.) If the clamp came loose from the ductwork place it back around the ductwork, sliding it far enough back so that you can easily place the ductwork around the air handler collar.
2. Once the ductwork has been placed around the collar move the clamp up to and around the ductwork and collar. (Pay special attention that the clamp is around the collar and inner ductwork but inside the outer ductwork. If it is placed around the outside of the ductwork the duct will roll up and prevent air flow.)
3. Tighten the clamp.

4. Give the ductwork a slight tug to ensure the ductwork is sufficiently fastened to the collar.
5. Replace the tape around the outside of the ductwork. (New tape might be needed to ensure good adhesion.)
6. Turn **ON** the Air Handler breaker (CB6 – 40A or HVAC/AR Handler Main) in the electrical cabinet located by the entrance door.

### REVISION HISTORY

REV	DATE	AUTHOR	PRIMARY REASONS FOR CHANGE
0	June 19, 2000	K.Keshena	Created procedure specifically for the Ellis & Watts van that incorporates E&W procedure to remove air duct.