

TABLE OF CONTENTS

TABLE OF CONTENTS	1
GRADIENT DRIVER FUNCTIONAL CHECKS - SGD BASE	2
1- INTRODUCTION	2
2- SCA FRONT PANEL	2
3- FRONT PANEL DISPLAY	2
4- RUNNING LOCAL WAVEFORMS.....	4
4-1 Running Waveforms	7
4-2 Reset Cabinet for Normal System Operation.....	12
5- DISPLAY CODES	13
REVISION HISTORY.....	15

GRADIENT DRIVER FUNCTIONAL CHECKS - SGD BASE

1- INTRODUCTION

The SGD Base (AN8280G-TK) Cabinet is a system consisting of three switch-mode amplifiers, a switch-mode power supply and a system-control assembly mounted in a rack assembly.

Provision is made to generate waveforms for use in testing amplifier the hardware. Waveform equations are generated by the processor and stored in a RAM. A PAL provides the write and read control functions for the address counter and parallel-serial shift register, and the required data clock. A relay bank selects between test and user waveforms. Wave-form data is shifted serially onto the X,Y or Z data lines with the same format as data from the user.

2- SCA FRONT PANEL

Refer to illustration 2-1 for SCA front panel display. It consists of four alpha-numeric displays and four switches. In addition, there is a green LED to the right of the display which indicates the presence of +5V logic power for the display.

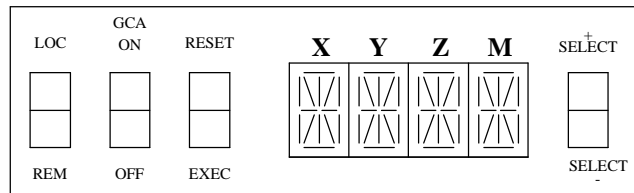

ILLUSTRATION 2-1
SCA DISPLAY

3- FRONT PANEL DISPLAY

The front panel annunciator will display messages depending upon whether the system is operating normally, or whether an error condition exists. Refer to Illustration 3-1 below.

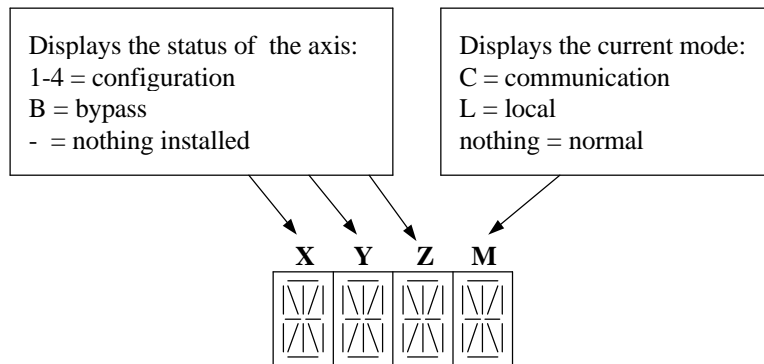

ILLUSTRATION 3-1
DURING NORMAL OPERATION

The first three digits display the status of the X, Y and Z axes. 1 through 4 signify compensation options “1-4” which correspond to preset values to optimize the gradient coil in use. The compensation option for the Signa BRM coil is 4. The

“B” means that the amplifier is by-passed, or disabled, allowing the remaining axe(s) to operate normally. A dash in the space means that the system does not recognize the presence of an amplifier.

There are two types of error in the system: *overload* and *fault*. *Overload* errors result in the amplifier being disabled, but not the PSU. *Fault* errors disable (or prevent enabling) both the amplifier and the PSU.

When an error occurs, the display will sequentially display a message, depending on the error. Refer to Illustration 3-2 for sample display sequences.

Sample Display Sequences

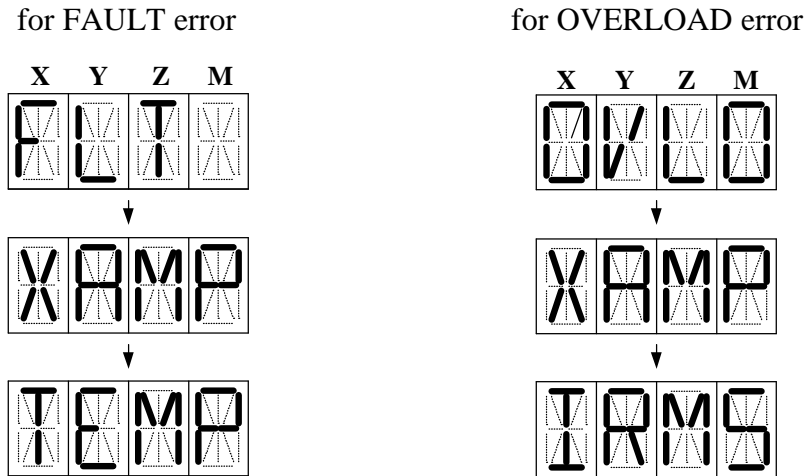

ILLUSTRATION 3-2
SAMPLE DISPLAY SEQUENCES

4- RUNNING LOCAL WAVEFORMS

The SGD Base cabinet can be reconfigured to run waveforms generated locally on the SCA Board. This can be useful to verify functionality of the gradient hardware independent of the input signal coming from the TPS in the systems cabinet.

1. Confirm that the SCA Display reads 444L. Refer to the SCA Display Illustration 2-1. Set the Local mode by pressing **LOC** on the **LOCAL** or **REMOTE** switch function. See Illustration 4-1.

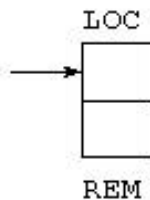
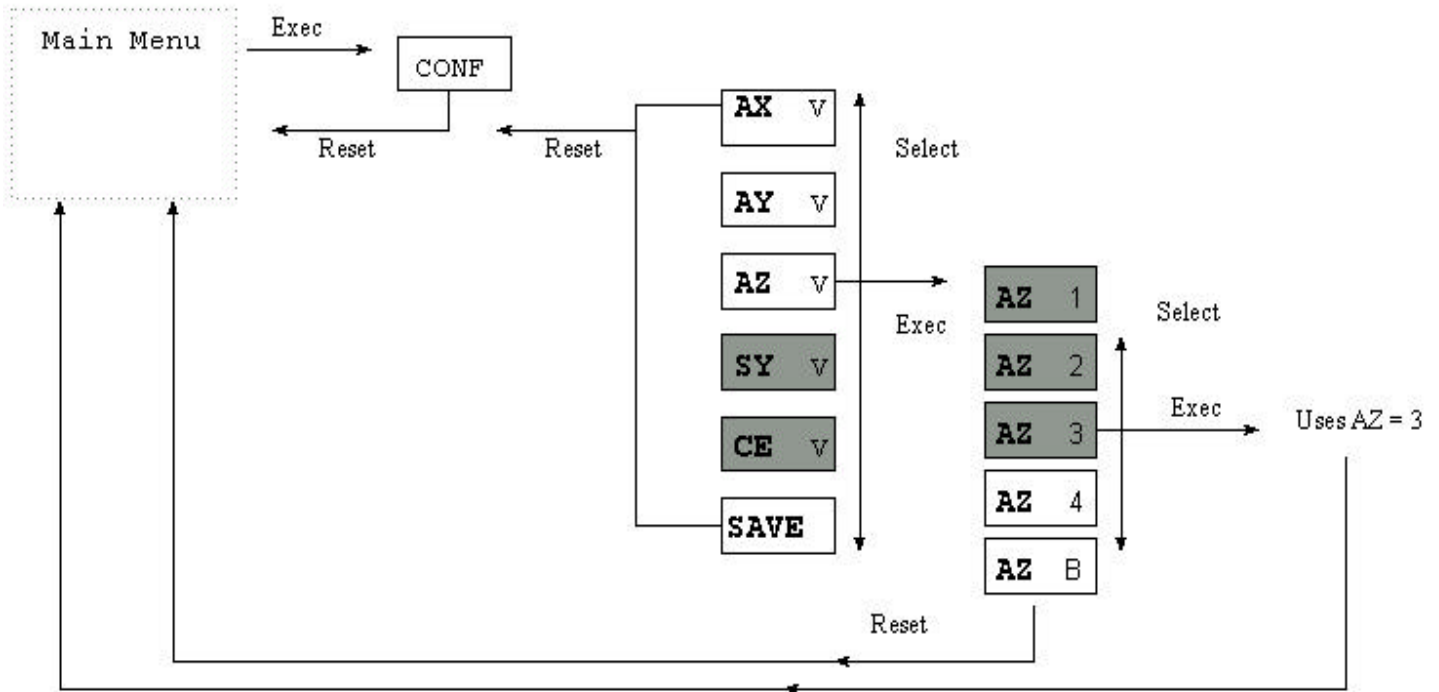

ILLUSTRATION 4-1
LOCAL/REMOTE BUTTON

2. Push **EXEC** on the SCA Display to enter the Main menu. See Illustration 4-2.



NOTE: The shaded boxes indicate choices available in the menu but you shouldn't choose these options for this procedure.

ILLUSTRATION 4-2
FLOW CHART OF CONFIG MENU

Refer to Illustration 4-2 above for the following commands:

1. Push EXEC again. CONF will be on the SCA Display.
2. Push EXEC to enter the Config. Submenu.
3. To select a specific axis to configure use the SELECT switch function to scroll through the choices. AX refers to the x axis, AY refers to the y axis, and AZ refers to the z axis.
4. Push EXEC to enter the axis to configure. Scroll through the choices by using the SELECT switch function. Refer to Table 4-1 of configurations for explanations of configurations.

TABLE 4-1
CONFIGURATION SETTINGS

Configuration	Application (Nominal full scale output current)
1	Spare, 150 Amps
2	Spare, 150 Amps
3	Spare, 200 Amps
4	Signa 1.0/ 1.5T, 200 Amps

Note

The choices are **1...4** and **B** (bypass). Don't use 1, 2, or 3 for any of the axes. The only configurations that can be used on Signa systems are 4 and B.

There are three configuration possibilities for the axes.

1. All three axes set to 4 (waveform drives all 3 axes)
2. Two axes set to 4; one axis set to B (2 axes driven; one bypassed)
3. One axis set to 4; two axes set to B (1 axis driven; two bypassed)

5. Push **RESET** to return to the Main menu.

4-1 Running Waveforms

Refer to Illustration 4-3 below for the following commands:

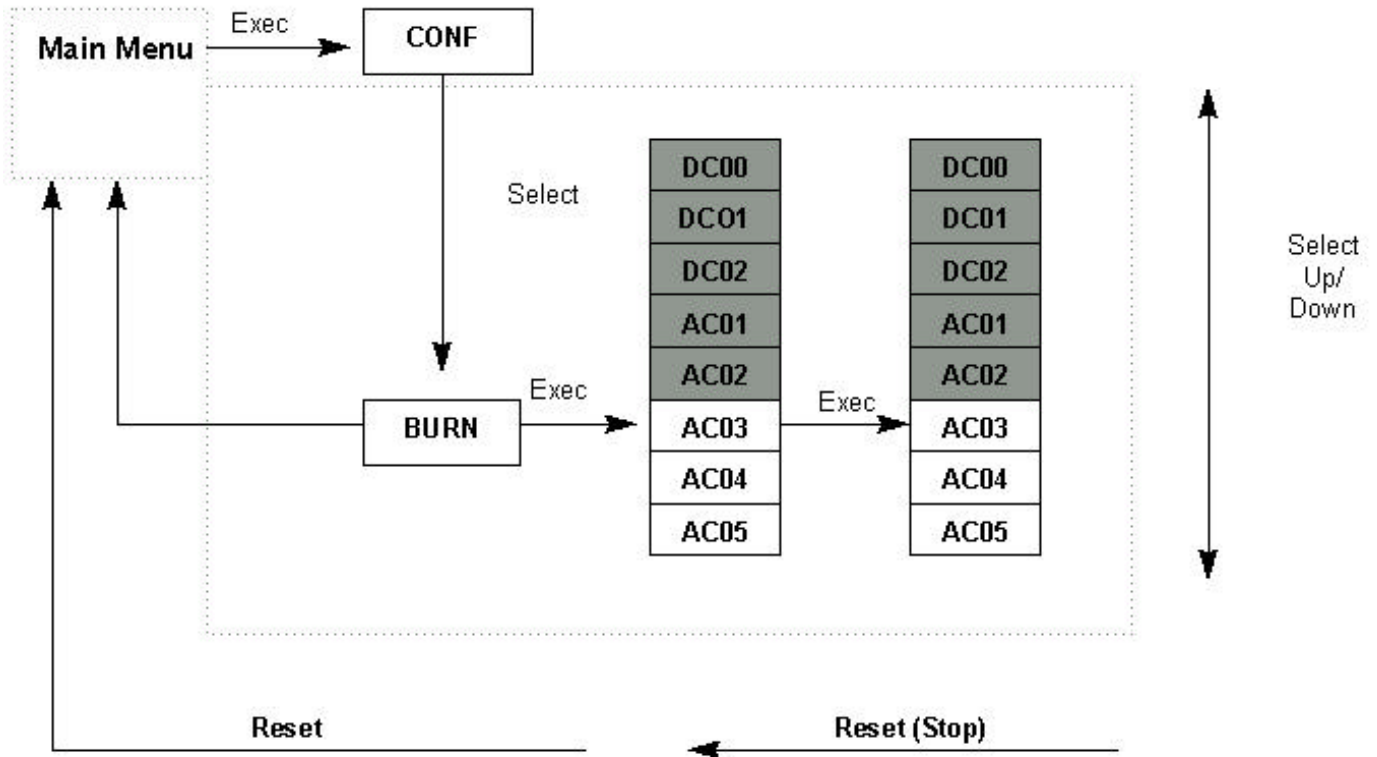

NOTE: The shaded boxes indicate selections available in the menu but you shouldn't choose these for this procedure.

ILLUSTRATION 4-3
FLOW CHART FOR BURN-IN MENU

1. From the Main menu push EXEC . Use the SELECT switch function to scroll through options until finding BURN.
2. Push EXEC to enter the Burn-in submenu.

- Use the **SELECT** button to scroll through the choices for different waveforms. Table 4-2 contains explanations for the only choices that should be used for this procedure.

TABLE 4-2
BURN-IN SUBMENU

Location	Display	Meaning
Burn-in menu	AC03	Bipolar trapezoid, $I_p=FS^*$, $Tr^*=1.15ms$, $Th^*=2 ms$, $Tt=2.3 ms$, $Th^*= 2 ms$, $Tr=1.15ms$, $Toff^*=55.4ms$, $duty^*= 13.4\%$
	AC04	Unipolar trapezoid, $I_p= FS$, $Tr=1.15ms$, $Th= 4ms$, $Tf= 1.15ms$, $Toff=57.7 ms$, $duty= 9.8\%$
	AC05	122Hz sine wave, $I_{pp}= 5\%$ of FS

*where FS = Full scale current in Amperes
 Tr = ramp time
 Th = plateau time
 Toff = Time at zero current
 duty = percent of time not at zero

- Push **EXEC** and use **SELECT** to scroll through the choices.
- Repeat steps for all three axes. It is recommended to select the same waveform for each axis, so comparisons of the output waveforms can be made.

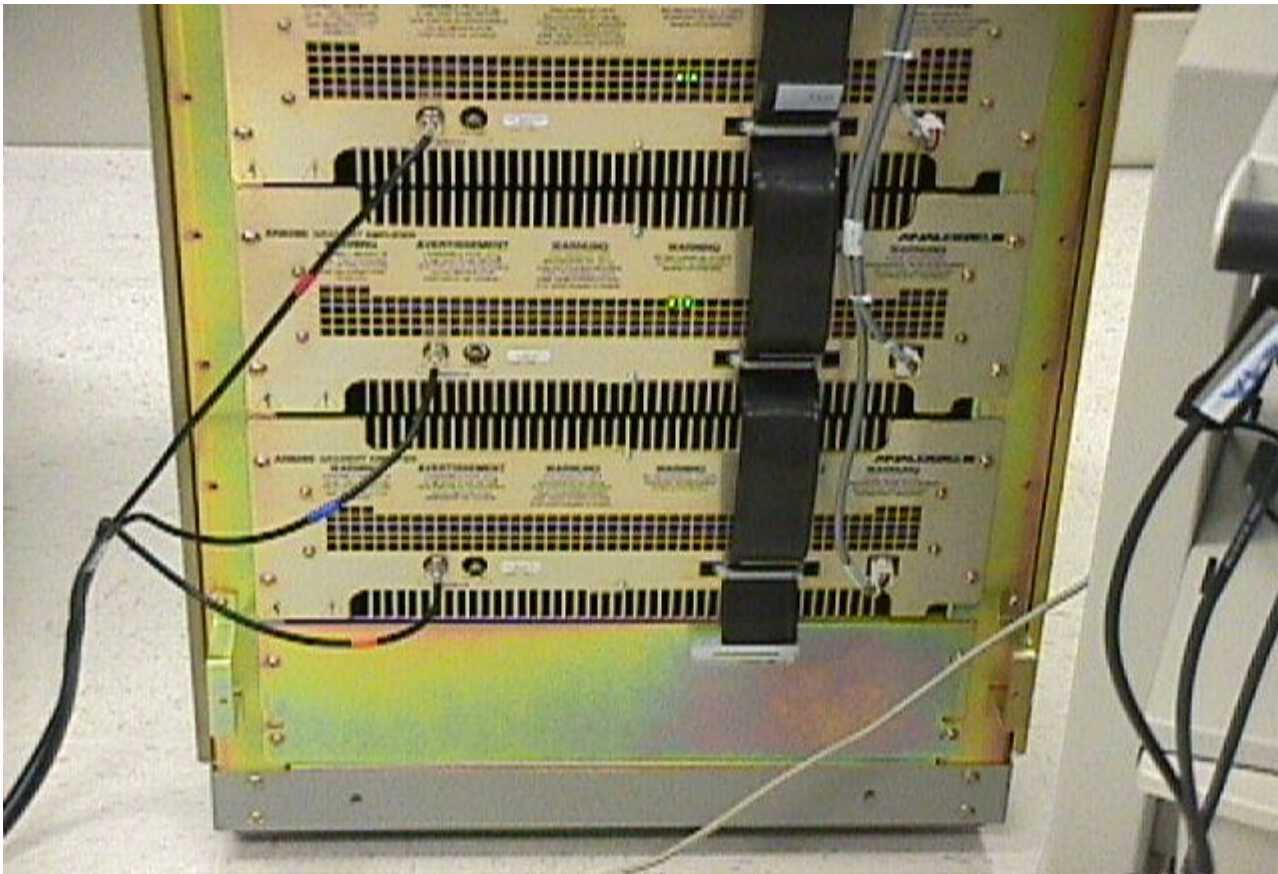

ILLUSTRATION 4-4
SCOPE CONNECTIONS

1. Push EXEC to run the waveform that was selected. Connect oscilloscope to desired amplifiers as shown in Illustration 4-4. Each amplifier's output should be the same.

Refer to Illustrations 4-5 through 4-7 for expected waveform outputs. The settings on the oscilloscope might need adjusted to obtain accurate picture. Refer to Illustrations 4-5 through 4-7 for proper settings. If the waveforms are different refer to the *SGD Base Cabinet Troubleshooting Flowchart, GD2TSA1.DOC*.

Note

If only one of the axes waveforms is different try swapping amplifiers to isolate/verify the problem.

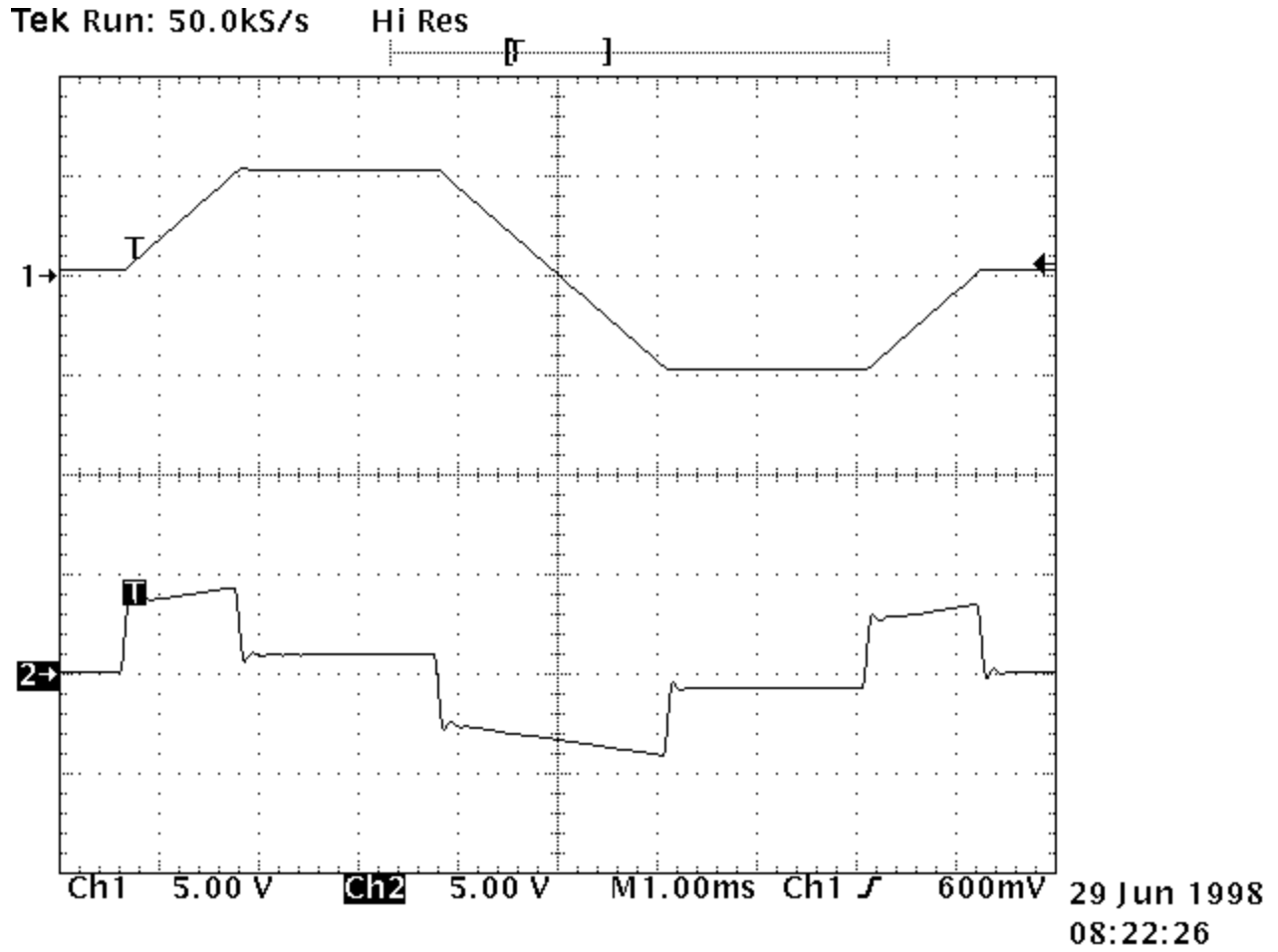
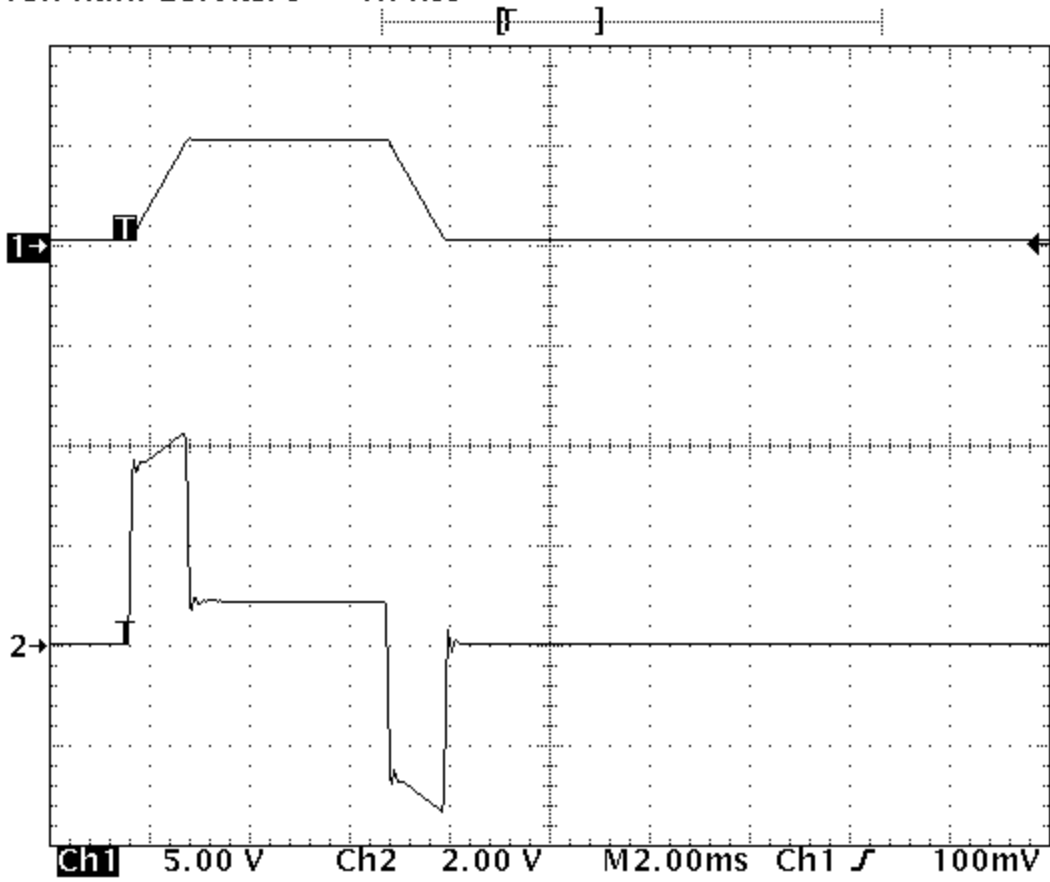

ILLUSTRATION 4-5
AC03 WAVEFORM - BIPOLAR TRAPEZOID

Tek Run: 25.0kS/s

Hi Res



29 Jun 1998
08:25:54

ILLUSTRATION 4-6
AC04 WAVEFORM - UNIPOLAR TRAPEZOID

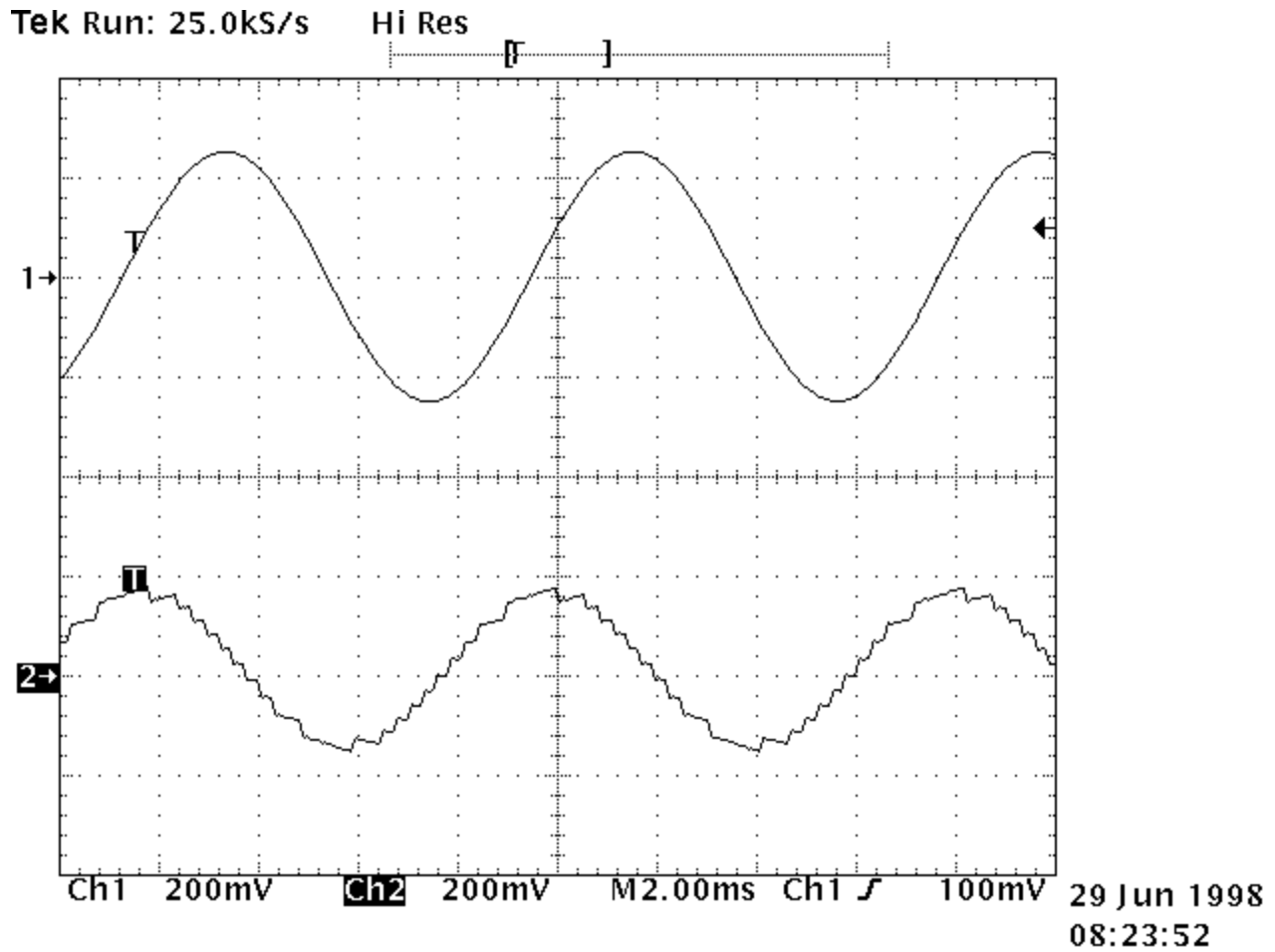

ILLUSTRATION 4-7
AC05 WAVEFROM - SINE WAVE

4-2 Reset Cabinet for Normal System Operation

1. Refer to Illustration 4-2 for a quick reference of the configuration menu.
2. Push EXEC to enter the config. menu.
3. Use the SELECT switch function to scroll through the axis choices.
4. Push EXEC and then SELECT. Set each axis back to 4.
5. Push RESET to return to the main menu.
6. Push EXEC to enter the config. menu.

7. Use the **SELECT** switch function to scroll through the axis choices
8. Find **SAVE** and push **EXEC**. This will save all three axis configurations.
9. Push **RESET** to return to the main menu.
10. Confirm that the SCA Display reads 444.. Set the Remote mode by pressing **REM** on the **LOC**al or **REM**ote switch function.

5- DISPLAY CODES

Table 5-1 is a description of the SCA display codes. They include error codes, test waveforms, configuration and status codes.

TABLE 5-1
SCA DISPLAY CODES

Item	Display Indications			Display Meanings
	First "word"	Second "Word"	Third "Word"	
No.	XYZM	XYZM	XYZM	Partial listing of the Remote Mode Display will similar to the Local Mode List
1	555			System is in Remote Stand-By mode
2	666			System is in Remote High Voltage coming up.
3	111			System is in Remote, Amps are Ready in Configuration; 1. Wrong config for Signa.
4	222			System is in Remote, Amps are Ready in Configuration; 2. Wrong config for Signa.
5	333			System is in Remote, Amps are Ready in Configuration; 3. Wrong config for Signa.
6	444			System is in Remote, Amps are Ready in Configuration; 4. Correct for Signa!
7	777			System is in Remote, Amps are Ready in Configuration; By-Pass.
8	---			System is in Remote, No Amps are installed.

The Amplifier Status codes, reported for the X, Y, and Z amplifiers as codes AA, AB, and AC on the front panel of the SCA, are found in Table 5-2.

TABLE 5-2
AMPLIFIER STATUS CODES

Status Codes X, Y, Z-Amp's A4 A3 A2 A1	Amplifier Status Condition
0	GCA not ready, no auxiliary voltage present
1	System Ready, GCA load compensation value #1
2	System Ready, GCA load compensation value #2
3	System Ready, GCA load compensation value #3
4	System Ready, GCA load compensation value #4
5	GCA not ready, auxiliary power present, HV off
6	GCA not ready, configured
7	Amplifier in Bypass Mode
8	unused
9	Power Module Fault (Over Current or Loss of Clock)
A	GCA not ready, not configured, HV on
B	Power module heatsink Temperature Fault
C	High voltage not present fault
D	unused
E	unused
F	RMS Current Overload

Amplifier Configuration Register

Refer to Table 4-1 which describes the configuration settings, including compensation and gain, of the amplifier. Gain settings change both the output scaling and the current monitor settings.

REVISION HISTORY

REV	DATE	AUTHOR	PRIMARY REASONS FOR CHANGE
0	Oct 3, 1997	J. Wolak	Initial version for SGD production introduction.
1	July 1, 1998	M. Whitlow	Addition of Waveform row test.