

# TABLE OF CONTENTS

<b>TABLE OF CONTENTS</b> .....	<b>1</b>
<b>1- INTRODUCTION</b> .....	<b>2</b>
<b>2- TOOLS AND MATERIAL REQUIRED</b> .....	<b>3</b>
<b>3- ENCLOSURE END COVERS REMOVAL</b> .....	<b>4</b>
<b>4- BRIDGE REMOVAL</b> .....	<b>7</b>
4-1 Fixed Sites.....	7
4-2 Mobiles.....	10
<b>5- FRONT END BELL REMOVAL</b> .....	<b>11</b>
5-1 Removing Front Patient Comfort.....	11
5-2 Removing Front Front End Bell.....	12
<b>6- REAR END BELL REMOVAL</b> .....	<b>13</b>
6-1 Removing Rear Patient Comfort.....	13
6-2 Disconnecting Incoming Power.....	14
6-3 Removing Rear End Bell.....	15
6-4 Disconnecting Cooling System.....	15
<b>7- FAILED GRADIENT BODY COIL REMOVAL</b> .....	<b>19</b>
7-1 Using the Coil Cradle and Cart.....	22
7-2 Removing the Failed Body Coil.....	24
7-3 Coil Replacement in Mobile Sites.....	27
7-3-1 Overview.....	27
7-3-2 Removing the Failed Gradient Body Coil.....	28
7-3-3 Prepare Lift Truck Aid.....	28
7-3-4 Picking up the Load.....	29
<b>8- REPLACEMENT COIL INSTALLATION</b> .....	<b>33</b>
8-1 Loading Replacement Coil on Cart.....	34
8-2 Moving Coil into Magnet.....	35
8-3 Aligning the Coil in the Bore.....	38
8-3-1 Install RF Coil.....	41
8-4 Connecting Replacement Coil.....	45
<b>9- REAR END BELL REPLACEMENT</b> .....	<b>47</b>
<b>10- FRONT END BELL REPLACEMENT</b> .....	<b>50</b>
<b>11- BRIDGE REPLACEMENT</b> .....	<b>52</b>
<b>12- ENCLOSURE END COVERS REPLACEMENT</b> .....	<b>56</b>
<b>13- SYSTEM RESTORATION</b> .....	<b>57</b>
<b>REVISION HISTORY</b> .....	<b>58</b>

**Description** - This describes the removal and replacement of the combined RF and gradient body coils in the various Signa Horizon systems **without** Cx Magnets. If you have a Cx magnet, please use procedure for Cx magnets, *Gradient Coil Replacement for BRM, BRM-D, & CRM in Cx, LCC, and Wideopen Enclosure Magnets* (gc1rea1a.pdf).

The procedure includes moving the RF body coil from the failed gradient coil to the replacement gradient coil. It also deals with making the replacement in the limited space of mobile MRI vans.

## 1- INTRODUCTION

The Epoxy-filled Gradient Coil is a field-replaceable unit (FRU). The coil is available in 1.0T and 1.5T versions. It consists of an inner and outer gradient coil, and each of these consists of an x, y, and z gradient winding. The windings are sealed in a strong adhesive. The inner gradient coil includes hose fittings that connect via 1/2-inch I.D. hoses to a heat exchanger, used to cool the entire assembly.

During manufacture, the inner coil is placed inside the outer coil, and the combination is then filled with an epoxy resin. This epoxy holds the inner and outer coils together, forming the Epoxy-filled Gradient Coil Assembly.

The RF body coil mounts inside the combined gradient coil. If the RF body coil is still operational, it will be necessary to move it from the failed gradient coil to its replacement.

While some of the following procedure can be accomplished by one person (connecting/disconnecting various cables, etc.), replacing a failed coil assembly is not a job for one person. The coil assembly weighs 2300 lbs (1045 kg), and the special cart and cradle weigh almost 1000 lbs (~450 kg); a minimum of four people should be available for moving this equipment.

**2- TOOLS AND MATERIAL REQUIRED**

- Epoxy-filled Gradient Coil cart (2134810), cradle (2134810-2), and accessory kit (2134810-4). (The part number of the combination is 2144093). Table 2-1 lists the contents of the accessory kit.
- Class 1 electric rider lift truck, 4-wheel, rated at 6000 lbs (in case the coil, cart, and cradle must all be lifted together— a necessity in mobiles); with forks a minimum of 56 inches long; with side shifter for easy width adjustment and lateral movement of forks.
- Non-magnetic tool kit (46-320273G1, G2, G3, or G4)
- 12-inch length of 1/2-inch I.D. hose
- 2 hose clamps for 1-inch O.D. hose
- 4-inch-long piece of copper tubing, 1/2-inch O.D.
- Roll of paper toweling
- Pair of latex gloves (optional)
- Non-magnetic torpedo level or similar

TABLE 2-1  
BRM ACCESSORY KIT CONTENTS/SPECIFICATIONS

Upper Level Items		Lower Level Items	
Qty.	Name	Qty.	Name
1	Ratchet Handle, 1/2-inch drive	4	Roller Wheel Assemblies (2121111)
1	Drive Shank, 1/2-inch to 3/8-inch	4	Wheels, polyethelene
1	17-mm Hex Socket, 3/8-inch drive	4	Large Roll Pins, 25 mm (2125505-2)
1	19-mm Hex Socket, 3/8-inch drive	4	Small Roll Pins, 6 mm (2123505)
1	3-inch Extension Shank, 3/8-inch drive	16	M10 x 50 Bolts, 17-mm hex head (2109866-24)
1	17-mm Wrench - Box/Open End		
1	19-mm Wrench - Box/Open End		
2	15/16-inch Wrench - Box/Open End		
4	Axles, stainless steel		
8	E-Clips, bronze		
All of the above come in a custom, dual compartment, hard shell case, measuring 18-1/2 x 14-1/2 x 7-7/16 inches. The kit part number is 2134810-4, which is part of 2144093 (including the gradient coil, cart, crate, and this kit).			

### 3- ENCLOSURE END COVERS REMOVAL

Perform the following steps at the front of the magnet:

1. Undock patient table and move aside.
2. While holding in the Patient Transport Dock Plunger (see Illustration 3-1), move the carriage to the rear of the magnet by pressing the IN FAST button on the magnet enclosure.

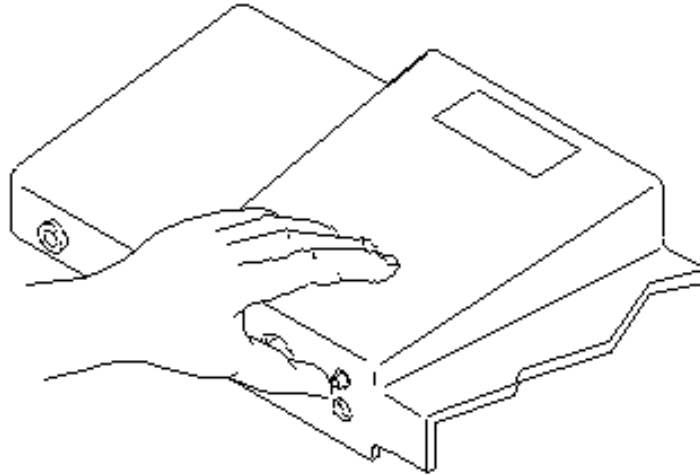

**PRESSING PATIENT TRANSPORT DOCK PLUNGER**  
ILLUSTRATION 3-1

- Remove power to Dock and Long Drive Assemblies by switching off circuit breaker MR1 A14 CB6 at rear of RF/Pen Cabinet (MR1) on Magnet Enclosure Power Supply (MEPS) Module (see Illustration 3-2).

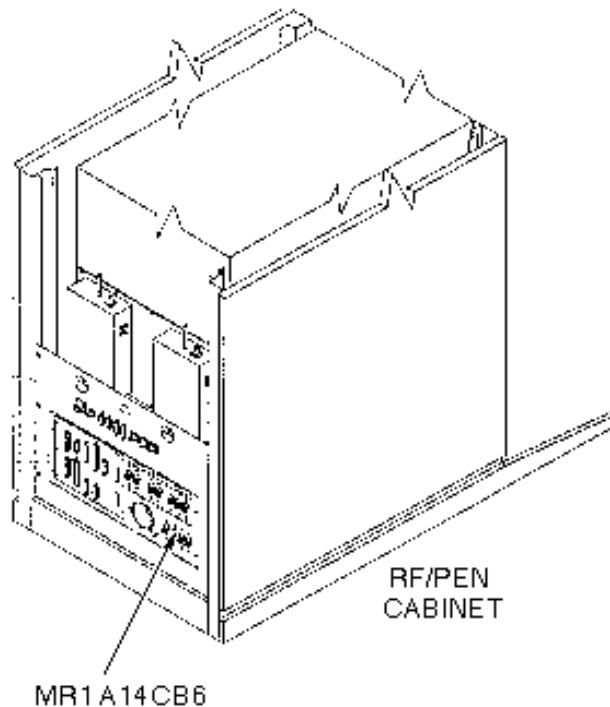

**LOCKOUT/TAGOUT**  
ILLUSTRATION 3-2

- Lock out and tag out circuit breaker MR1 A14 CB6 using appropriate OSHA procedure. (Refer to CD-ROM *Dir. 2187583-3 [or -2], MR Release Signa 5x/8x Service Methods, Renewal Parts and Service Tools, Safety, Section 6, OSHA LOCKOUT/TAGOUT REQUIREMENTS.*)

**WARNING!**

**PERSONAL INJURY AND/OR EQUIPMENT DAMAGE POSSIBILITY! FRONT AND REAR ENCLOSURES ARE HEAVY AND CUMBERSOME. AT LEAST TWO PEOPLE ARE REQUIRED TO LIFT AND MOVE THEM; THREE IS PREFERABLE.**

- Verify that voltage between MR1 A14 TP1 (+) and TP14 (-) is 0 Vdc.

6. For enclosure end cover removal, see Illustration 3-3.

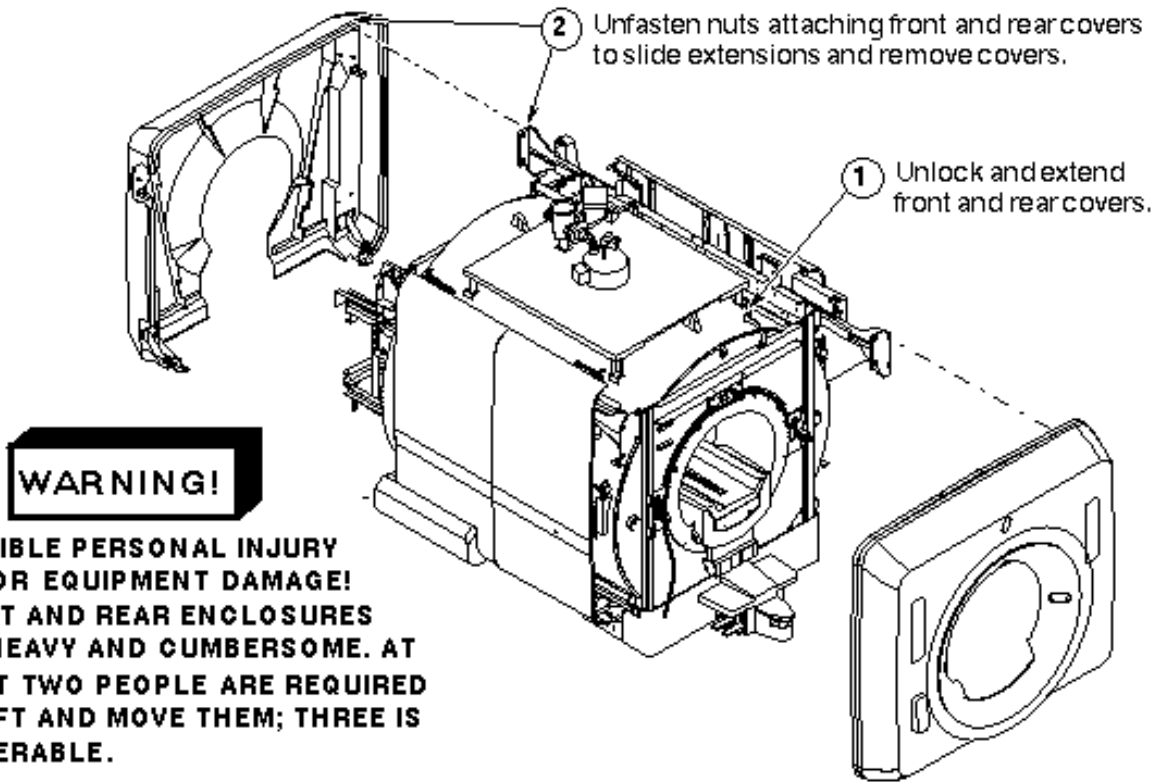

REMOVING ENCLOSURE END COVERS  
ILLUSTRATION 3-3

## 4- BRIDGE REMOVAL

### 4-1 Fixed Sites

See the twelve steps in the following three illustrations, or, for greater detail, perform the procedure Bridge Replacement.

1. Bridge Removal - Sequence 1 (Illustration 4-1).

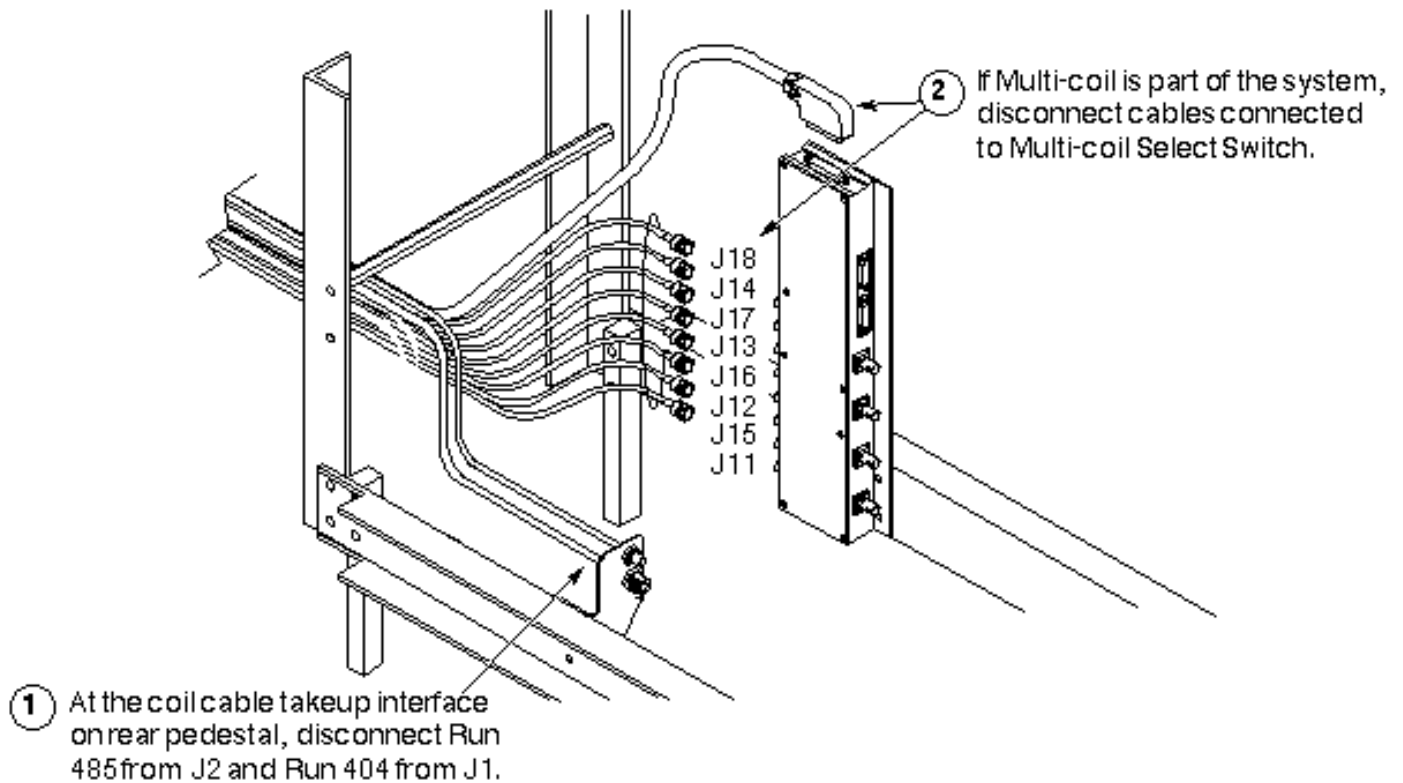

**BRIDGE REMOVAL - SEQUENCE 1**  
ILLUSTRATION 4-1

2. Bridge Removal -Sequence 2 (Illustration 4-2)

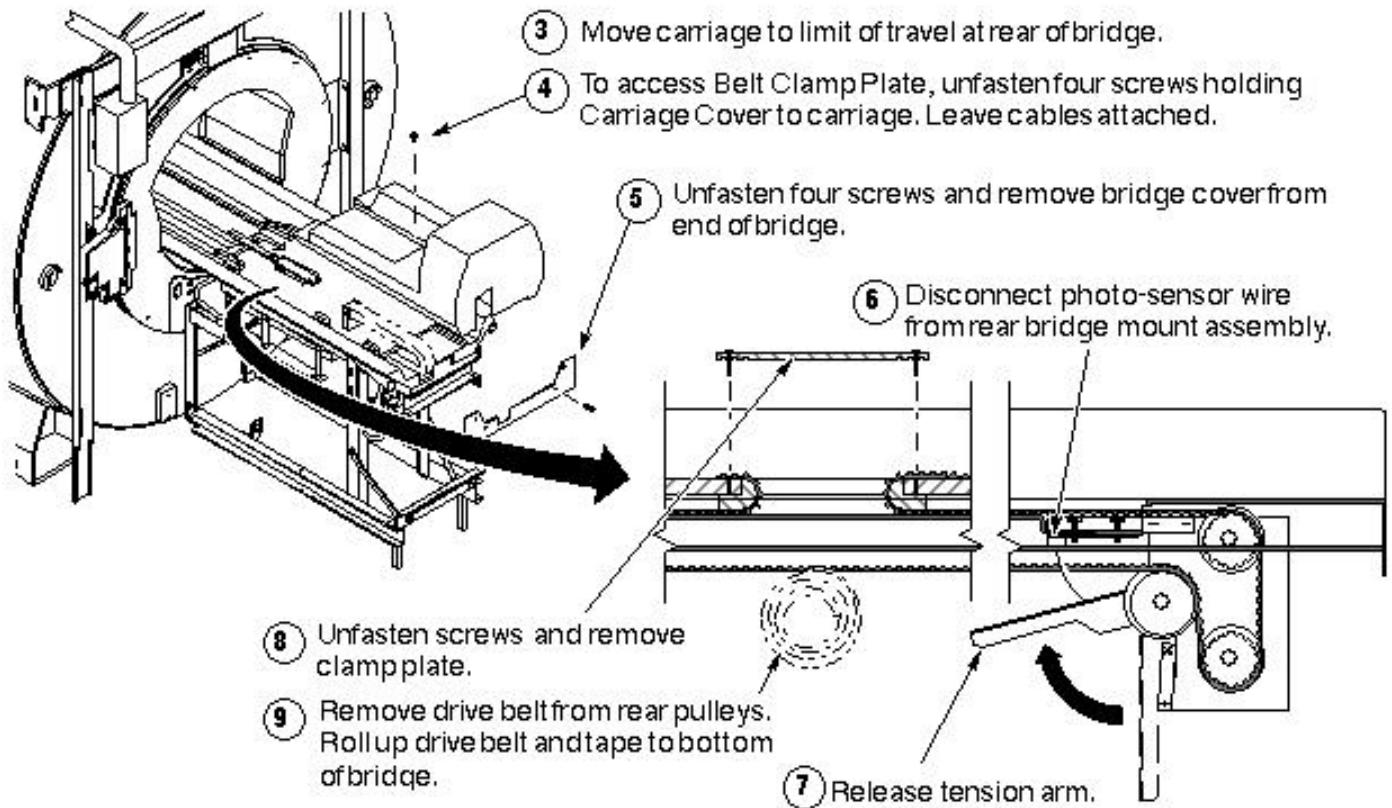

**BRIDGE REMOVAL - SEQUENCE 2**  
ILLUSTRATION 4-2

3. Bridge Removal - Sequence 3 (Illustration 4-3).

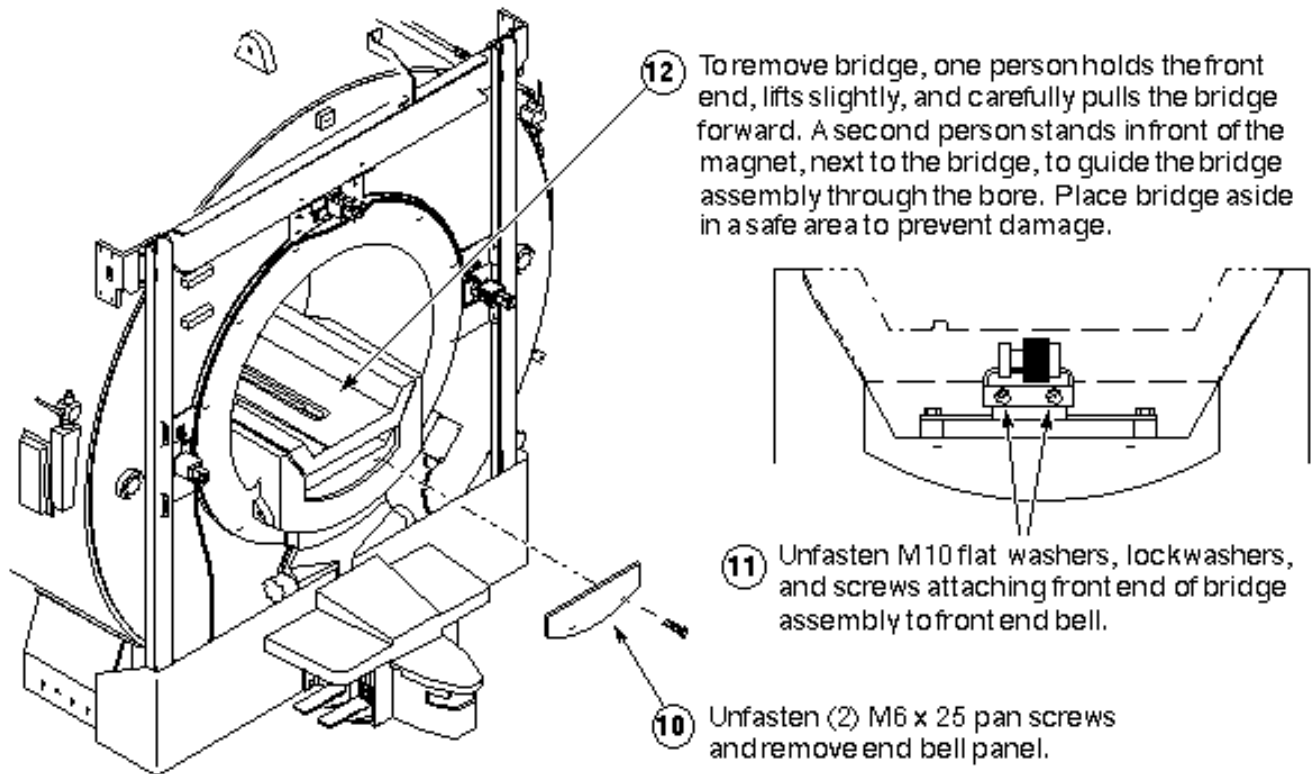

**BRIDGE REMOVAL - SEQUENCE 3**  
ILLUSTRATION 4-3

**4-2 Mobiles**

1. See Step 4-1 Fixed Sites
2. This describes the removal of the rear pedestal and rear bulkhead, necessary for preparing any mobile for replacement of the combined body coil. See Illustration 4-4.

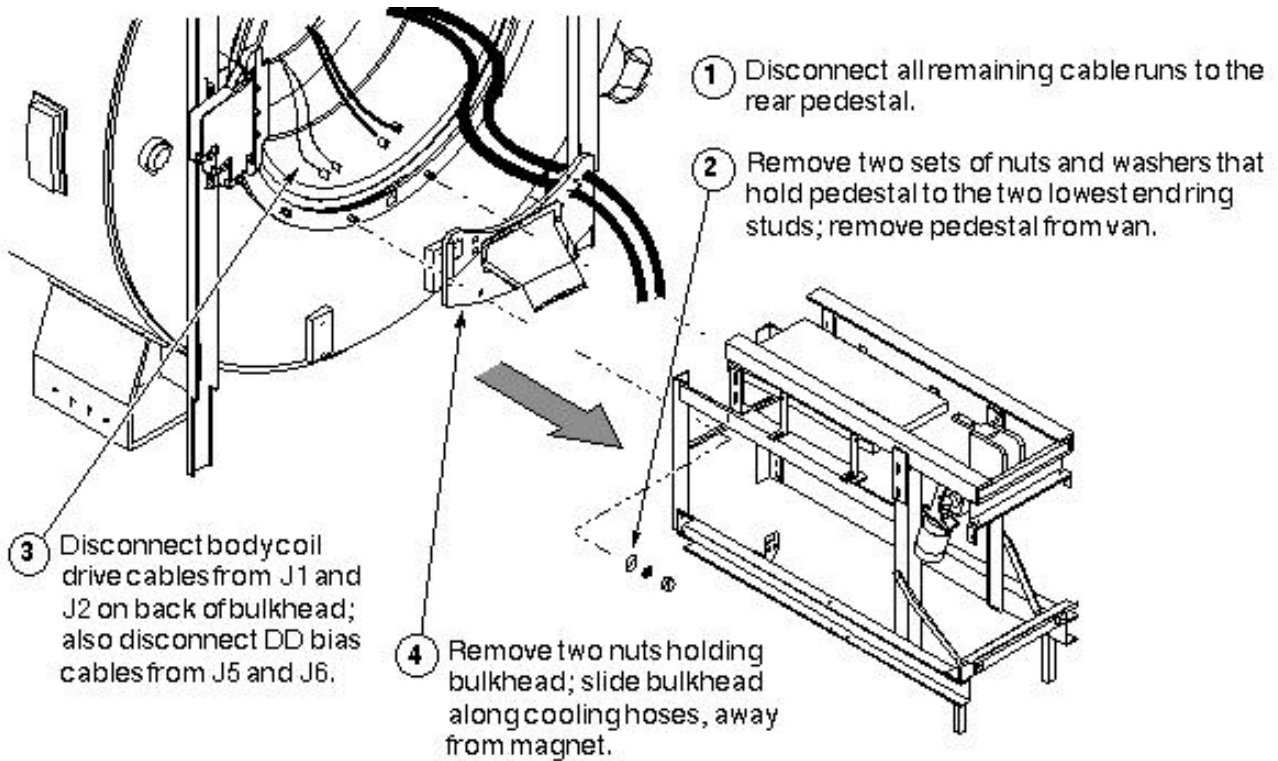

**REMOVING REAR PEDESTAL IN MOBILES**  
ILLUSTRATION 4-4

## 5- FRONT END BELL REMOVAL

### Note

Remove bridge first - Bridge must be removed before you can remove either end bell.

### 5-1 Removing Front Patient Comfort

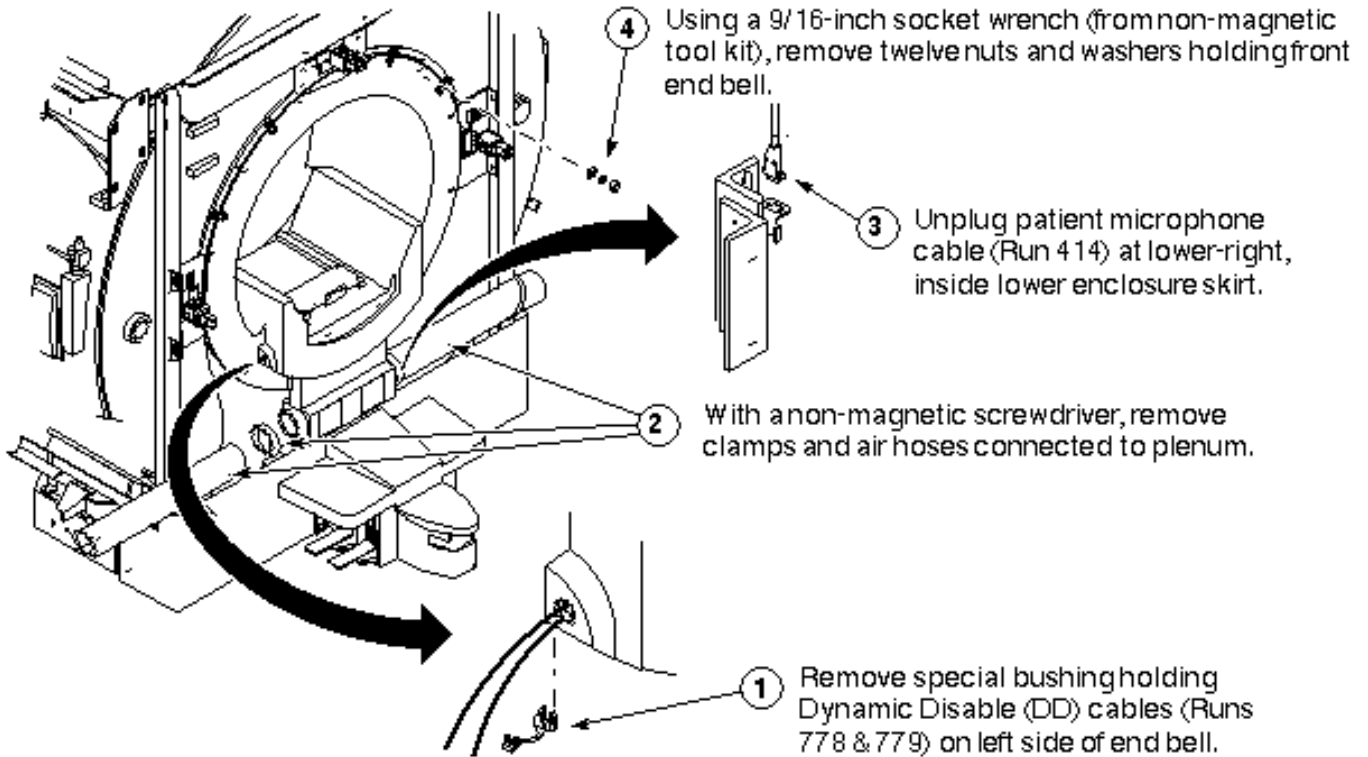

**REMOVE FRONT PATIENT COMFORT ITEMS**  
ILLUSTRATION 5-1

### Note

Magnishield enclosures - At some sites with Magnishield enclosures, it may be necessary to also remove the docking mechanism and lower skirt to provide sufficient clearance for the coil cart.

### 5-2 Removing Front Front End Bell

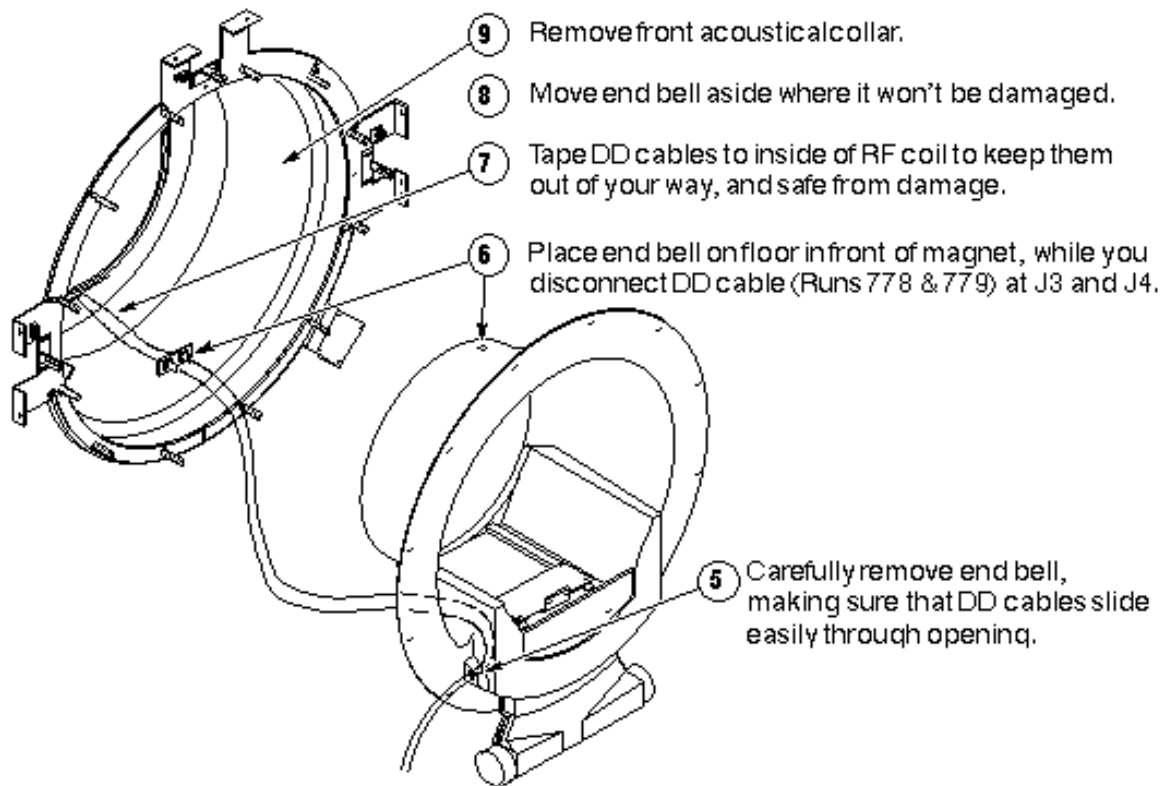

**REMOVE FRONT END BELL**  
ILLUSTRATION 5-2

## 6- REAR END BELL REMOVAL

### Note

Remove bridge first - Bridge must be removed before you can remove either end bell.

### 6-1 Removing Rear Patient Comfort

### Note

Microphone and speaker cables in mobiles - If you're working in a mobile, these cables will have already been removed prior to the removal of the rear pedestal.



**Equipment damage possibility. Hold Patient Comfort Module in place while removing the two screws that secure it. The alignment pins can break if too much downward stress is applied.**

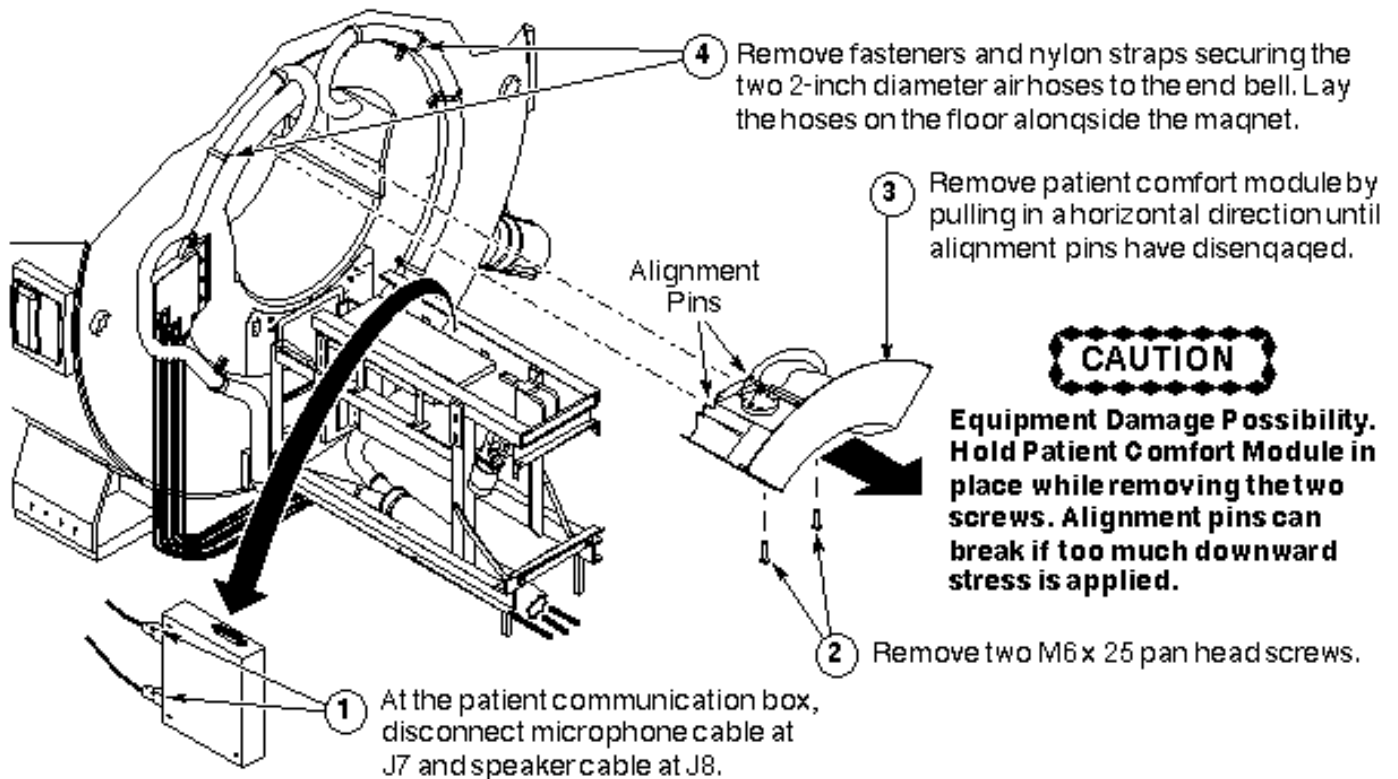

REMOVE FRONT PATIENT COMFORT ITEMS  
ILLUSTRATION 6-1

### 6-2 Disconnecting Incoming Power

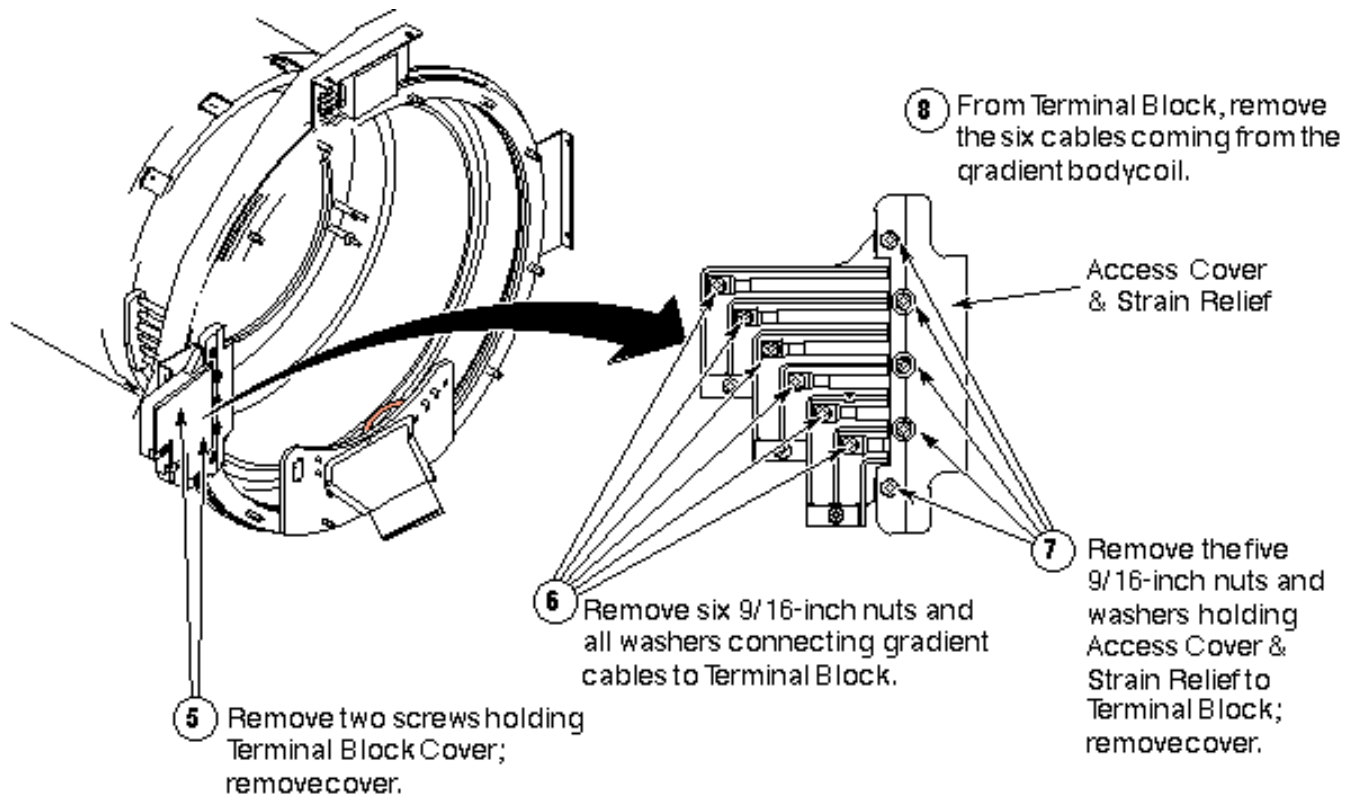

**DISCONNECT INCOMING POWER**  
ILLUSTRATION 6-2

### 6-3 Removing Rear End Bell

**CAUTION**

Possible equipment damage. When moving the Body Coil Drive Cables (usually colored blue), handle them with care. Do not kink them, or bend them sharply; damage can occur.

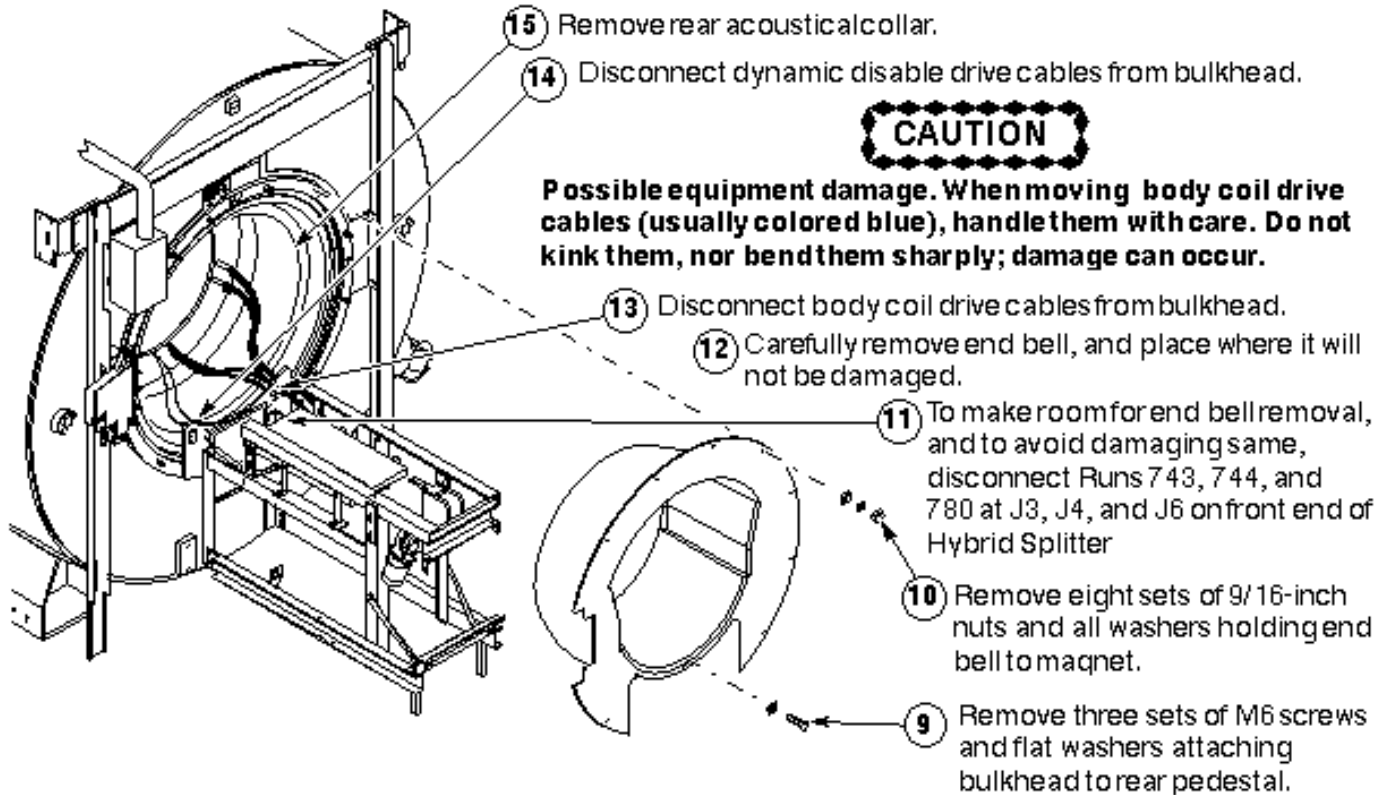

REMOVING REAR END BELL  
ILLUSTRATION 6-3

### 6-4 Disconnecting Cooling System

**CAUTION**

Coolant spillage possibility. The gradient coil cooling system is pressurized. Turn off the heat exchanger before disconnecting the coolant hoses at the rear of the magnet. This takes pressure off of the system, and helps avoid coolant from being sprayed all over the immediate area when hoses are removed from failed coil.

#### Note

Anti-freeze in coil - Depending on coolant hose length, the gradient coil assembly, hoses, and heat exchanger may hold as much as five gallons of coolant. Thirty-five percent of this is anti-freeze, which prevents the ionized water from freezing when the coil is shipped. When the hoses are removed from the coil, approximately two gallons of coolant remain in the coil.

**WARNING!**

**POSSIBLE EYE INJURY! WORKING WITH THE COOLANT IN THE EPOXY-FILLED GRADIENT COIL MAKES SPLASHING POSSIBLE. THIS COULD CAUSE EYE INJURY. BE SURE TO WEAR SAFETY GLASSES.**

**CAUTION**

**Personal contamination possibility. To avoid possible contamination from contact with the coolant used in the gradient coil assembly, wear latex gloves. Failing that, be sure to wash your hands with soap and water as soon as the hose connections are completed.**

**Note**

Four hands are better than two - While it is possible for one person to disconnect the coolant hoses at the rear of the body coil, it is easier if two people do it, and there is less chance of spilling the coolant.

**Note**

Rear bulkhead in mobiles - In mobiles, where bulkhead has been removed from end ring, you might choose to slide the hose ends out of the bulkhead before connecting the ends together.

1. Disconnecting Cooling System: Steps 1-3

1 Turn off heat exchanger to take pressure off of cooling system, and to help prevent spillage of coolant.

2 Place several layers of paper towel beneath the coolant hose connection at rear of coil.

3 Wearing latex gloves and safety glasses, use non-magnetic screwdriver to loosen two hose clamps where coolant hoses attach to coil.

**Note:**  
Have two extra hose clamps nearby.

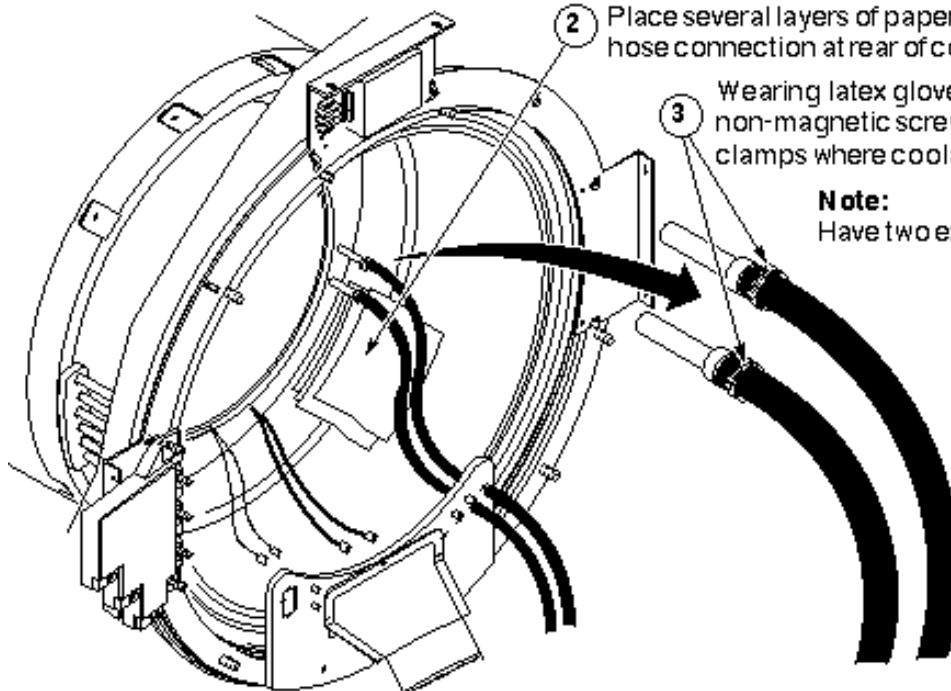

**WARNING!**

**POSSIBLE EYE INJURY!  
WORKING WITH THE  
COOLANT IN THE COIL  
MAKES SPLASHING  
POSSIBLE. THIS COULD  
CAUSE EYE INJURY. BE  
SURE TO WEAR SAFETY  
GLASSES.**

**DISCONNECTING COOLING SYSTEM: STEPS 1-3**  
ILLUSTRATION 6-4

**Note**

Four hands are better than two - While it is possible for one person to disconnect the coolant hoses at the rear of the body coil, it is easier if two people do it, and there is less chance of spilling the coolant.

2. Disconnecting Cooling System: Steps 4–8

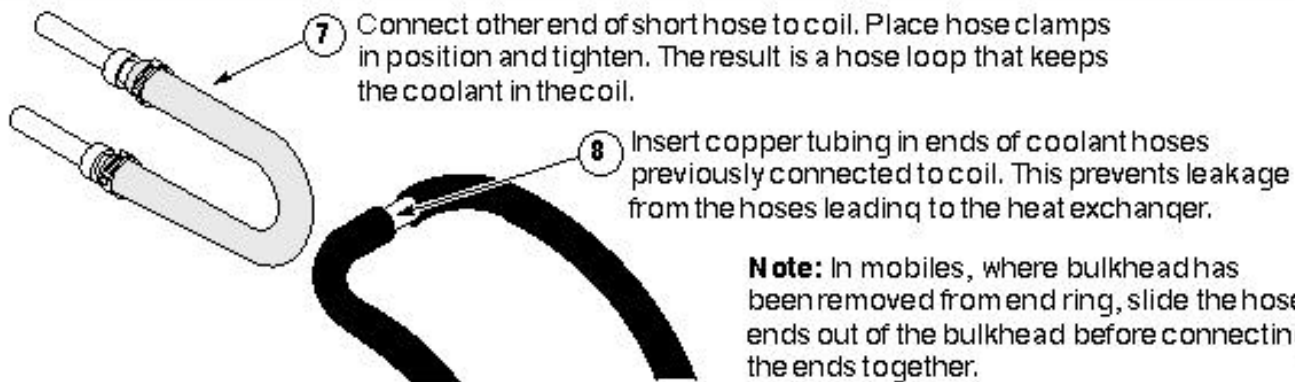
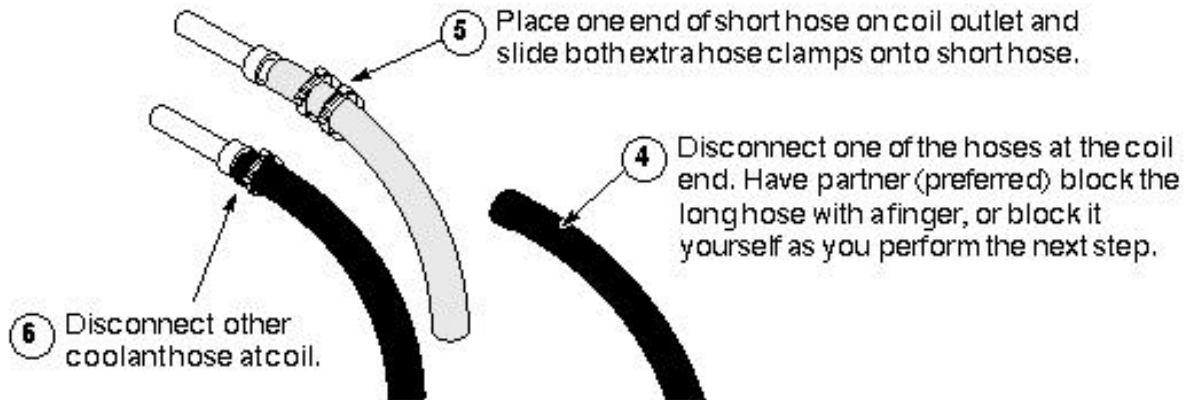

DISCONNECTING COOLING SYSTEM: STEPS 4–8  
ILLUSTRATION 6-5

## 7- FAILED GRADIENT BODY COIL REMOVAL

The gradient body coil is now completely disconnected. At this point, you may follow either of two procedures:

- If the RF Body Coil is operational, it must be removed for later installation in the replacement gradient coil. In this case, go to step 1 below,  
**OR**
  - If the RF Body Coil is to be replaced along with the gradient coil, go on to the following section.
1. RF power and DD Board Bias cables shall have already been disconnected in previous steps; ends should be taped to inside of coil.

### **Note**

Handling the RF body coil - While it is possible for two people to move an RF body coil with reasonable ease, use three people for this procedure.

### **Note**

Removal of RF body coil in mobiles - If the RF body coil is operational, and is to be set aside, it is generally possible to remove it from the front or the rear of the magnet in a mobile van (as opposed to the gradient coil having to be changed only through the rear door of the van). The choice is yours, based on space available (for setting the RF coil aside, preferably inside the van), and the ease and convenience of movement around the magnet itself. Either way, you should have three people available to do it.

2. This procedure requires three people. It also requires two nylon tracks (P/N), which are 1/4-inch thick, one inch wide, and 60 inches long. In each end of the track are two holes; one is smooth and goes all the way through, and the other is threaded and goes partially through. Two tracks come with each replacement Epoxy-filled Combined Gradient Coil.
3. The three parts steps below show all of the necessary steps for removing the RF body coil.
  - 3-1. Placing the RF Body Coil Installation Tracks

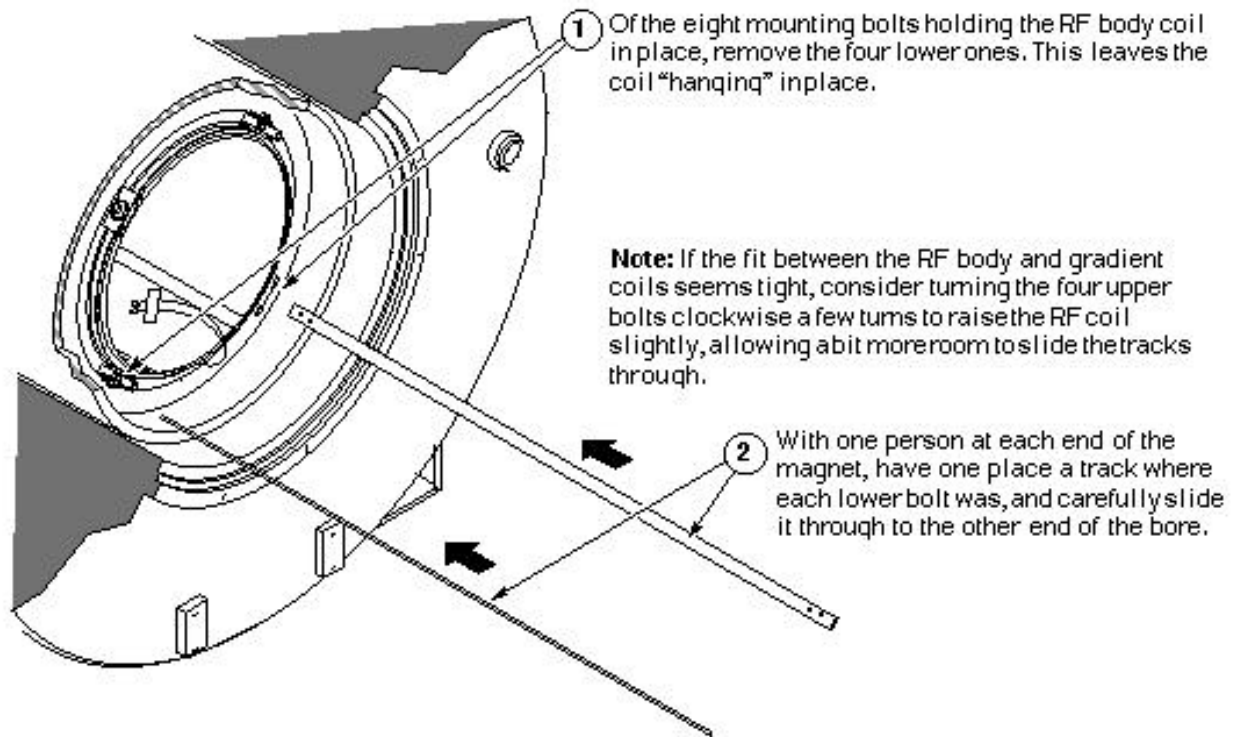

**PLACING THE RF BODY COIL INSTALLATION TRACKS**  
ILLUSTRATION 7-1

### 3-2 Attaching the RF Body Coil Installation Tracks

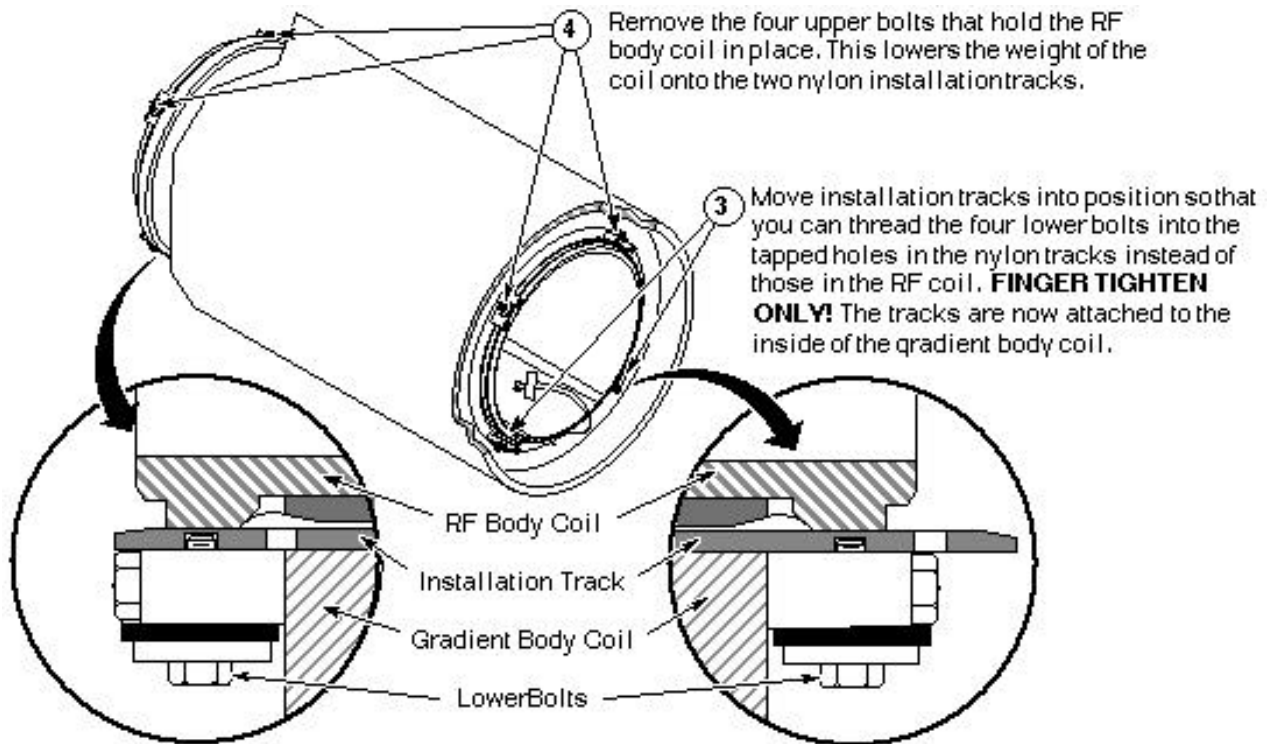

ATTACHING THE RF BODY COIL INSTALLATION TRACKS  
ILLUSTRATION 7-2

### 3-3. Removing the RF Body Coil From the Gradient Coil

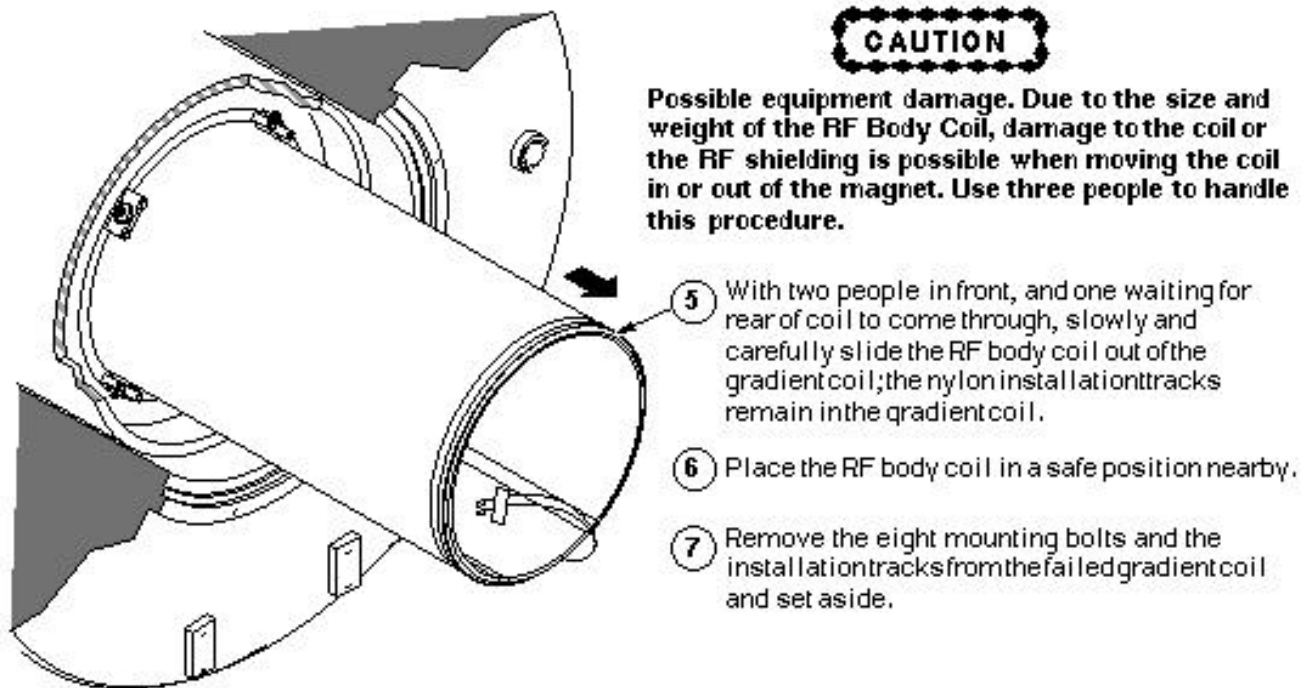

REMOVING THE RF BODY COIL FROM THE GRADIENT COIL  
ILLUSTRATION 7-3

**Note**

Making more room for the tracks - If the fit between the RF and gradient body coils seems tight, consider turning the four upper bolts clockwise a few turns to raise the RF coil slightly, allowing a bit more room to slide the tracks through.

Go on to the next section 7-1 Using the Coil Cradle and Cart.

**7-1 Using the Coil Cradle and Cart**

The Epoxy-filled Gradient Coil cradle and cart are used to install and remove the Epoxy-filled Gradient Coil (with or without the RF body coil) at the magnet. The components are called out in Illustration 7-4 look them over carefully. It may be helpful, also, to refer to revised Service Note 60880, of December, 1995.

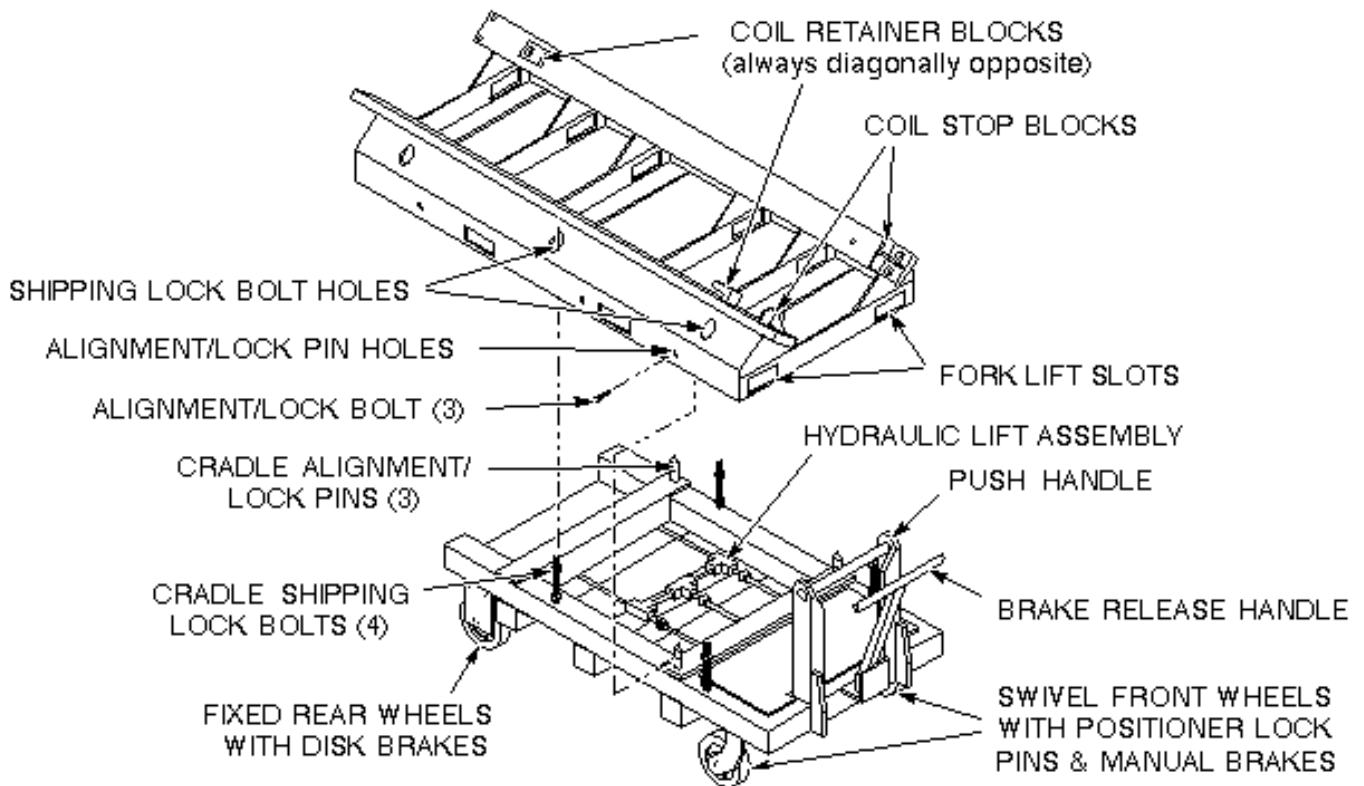

**GRADIENT BODY COIL CRADLE & CART NOMENCLATURE**  
ILLUSTRATION 7-4

**WARNING!**

**EQUIPMENT DAMAGE HAZARD! DO NOT USE THE PATIENT TABLE TO SUPPORT OR TRANSPORT THE GRADIENT COIL. THE PATIENT TABLE IS RATED AT 300 LBS (136 KG). THE GRADIENT COIL WEIGHS APPROXIMATELY 3.5 TIMES THE RATING OF THE PATIENT TABLE. USING THE TABLE TO SUPPORT THE GRADIENT COIL IS LIKELY TO DAMAGE IT STRUCTURALLY.**

**CAUTION**

**Personal injury/equipment damage possibility. The combination of the coil, cradle, and cart weighs almost 3300 pounds (~1230 kg). To avoid personal injury and/or equipment damage, and to maintain complete control over this amount of weight, a minimum of four people must be used to move the combination.**

Moving the almost 3300 pounds of the combined coil, cradle, and cart requires a minimum of four people; therefore, follow the steps below to prevent damage to the equipment, and for the safety of those using that equipment.

The next steps that prepare the empty cradle and cart to receive the failed body coil.

- ① Be sure that the four Cradle Shipping Lock Bolts have been removed and set aside.
- ② Have a fork lift raise the cradle (or pallet) above the cart (if cradle is not already there).
- ③ Position cart beneath cradle with Cradle Alignment/ Lock Pins aligned with their holes in the cradle.
- ④ Lower empty bodycoil cradle(or pallet) onto the cart.

**WARNING!**

**POSSIBLE PERSONAL INJURY AND EQUIPMENT DAMAGE! NOT HAVING THE CRADLE ANCHORED TO THE CART COULD CAUSE THE COIL/CRADLE TO TIP. THE THREE CRADLE ALIGNMENT/LOCK BOLTS MUST BE IN PLACE BEFORE THE COIL IS ROLLED ONTO THE CART.**

- ⑤ Install the three Cradle Alignment/Lock Bolts.
- ⑥ Roll cart/cradle into scanroom.

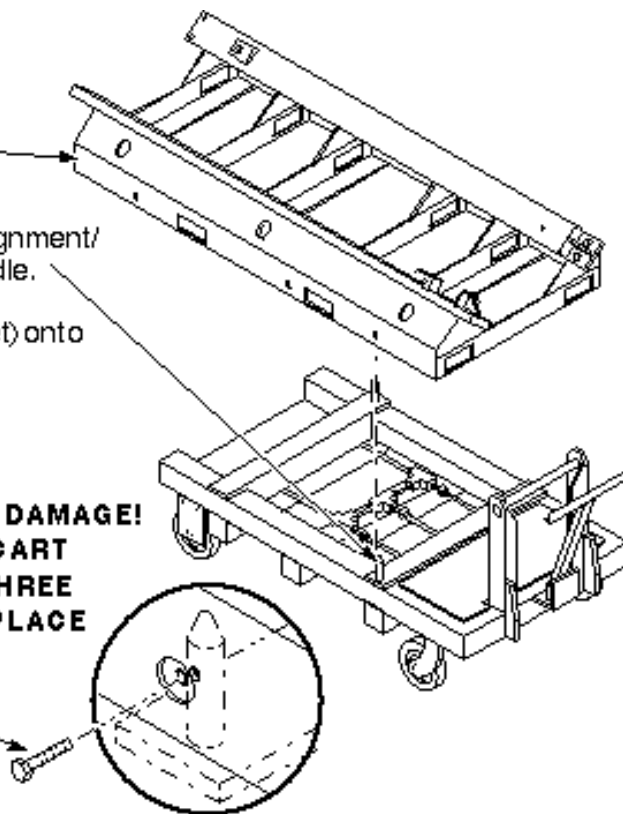

**PREPARE THE CART AND CRADLE**  
ILLUSTRATION 7-5

See Illustration 7-6 for the steps to assembling the Roller Wheel Assemblies, and mounting them on the failed coil.

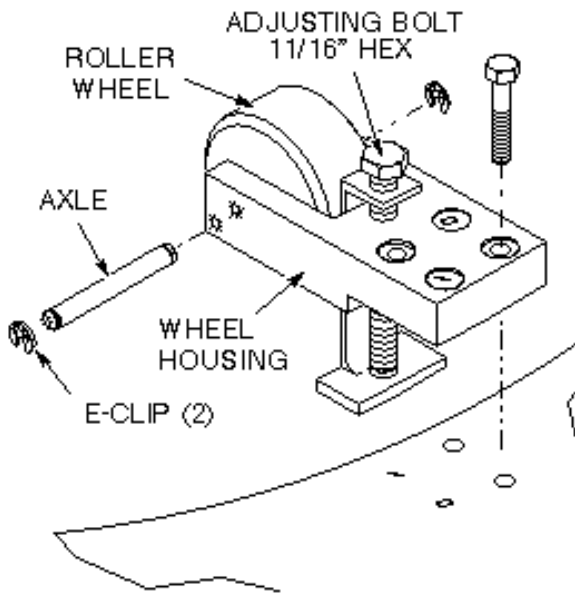

- 1 From the accessory kit, get the four Roller Wheel Assemblies (2121111), and M10x50 bolts, for mounting to the coil, two at each end.
- 2 Back the adjusting bolt all the way out by turning it counterclockwise.
- 3 With a non-magnetic screwdriver, remove one of the e-clips, and remove wheel and axle from each housing.
- 4 Place each Wheel Housing in position over the four threaded holes on the coil and fasten with four bolts.
- 5 Turn the adjusting bolt clockwise on all four Roller Wheel Assemblies to raise the coil to the point that the wheels and axles can be installed.
- 6 Note in which position to install wheels and axles.

Use upper hole for GE magnets with passive or resistive shim.

Use lower hole for magnets without passive or resistive shim.

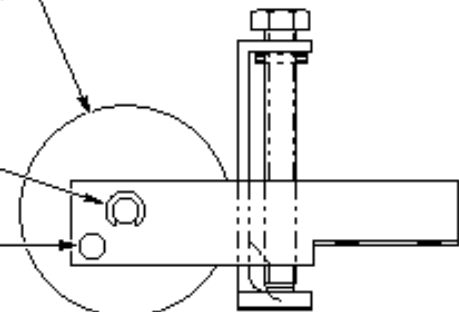

**MOUNTING THE ROLLER WHEEL ASSEMBLIES**

ILLUSTRATION 7-6

**Note**

Roller wheel and axle positioning - In most cases, the axle/wheel combination is positioned in the higher of the two holes in the wheel housing (higher being relative to a side view of the housing). The lower hole is used for placement of body coils in magnets that have no resistive shim coils (This magnet bore is larger in diameter; therefore, the body coil must sit higher in the bore).

**7-2 Removing the Failed Body Coil**



**PERSONAL INJURY POSSIBILITY! WHEN REMOVING OR REPLACING THE RUBBER PADS THAT ARE LOCATED BENEATH THE BODY COIL, DO SO WITHOUT PUTTING YOUR FINGERS BETWEEN THE COIL AND THE MAGNET BORE. SERIOUS INJURY CAN OCCUR IF THE COIL SHOULD SUDDENLY SHIFT POSITION WITHIN THE BORE.**

Illustration 7-7 shows how to remove the rubber pads.

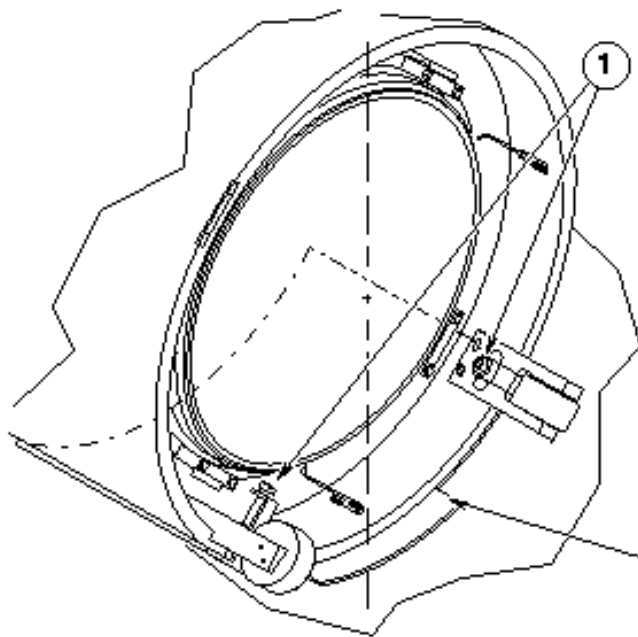

1 Turn the four adjusting bolts clockwise, just enough to raise the coil so that the rubber pads can be removed.

**WARNING!**

**POSSIBLE PERSONAL INJURY! WHEN REMOVING OR REPLACING RUBBER PADS LOCATED BENEATH THE BODY COIL, DO SO WITHOUT PUTTING YOUR FINGERS BETWEEN THE COIL AND MAGNET BORE. SERIOUS INJURY CAN OCCUR IF COIL SHOULD SUDDENLY SHIFT POSITION WITHIN THE BORE.**

2 Turn pads sideways and remove; set aside.

3 Turn the adjusting bolts counterclockwise to lower the wheels on the Roller Wheel Assemblies so the wheels contact the magnet bore.

Note - Number of alignment pads required

**REMOVING THE RUBBER PADS**  
ILLUSTRATION 7-7

**Note**

Number of rubber pads required - Save the rubber pads for use under replacement coil. GE magnets having resistive shim coils require two 6.5-mm-thick pads (2126201), one at each end of bore. Magnets having no resistive shim coils require the same two pads, PLUS three 9.5-mm-thick pads (2135234) at each end. Oxford magnets require two 9.5-mm-thick pads under each end.

**WARNING!**

**POSSIBLE PERSONAL INJURY AND/OR EQUIPMENT DAMAGE! NOT HAVING THE CRADLE ANCHORED TO THE CART COULD CAUSE THE CRADLE TO TIP WHEN THE COIL MOVES ONTO IT. THE THREE CRADLE ALIGNMENT/LOCK BOLTS MUST BE IN PLACE BEFORE THE COIL IS ROLLED ONTO THE CART.**

**CAUTION**

Equipment damage possibility. Early carts had left-hand threads on the Lift Assembly Height Adjuster, i.e., clockwise rotation lowered the assembly, and counterclockwise rotation raised it. Gradually, these carts are being modified for right-hand threads. Be sure to check the cart that you are about to use. Damage to the mechanism can occur if the bolt is turned the wrong way with the full weight of a coil and cradle on it. (also see Service Note 60880)

See the two-part Illustration 7-8 for steps necessary for placing the empty cradle/cart at the magnet, and loading the failed coil on it.

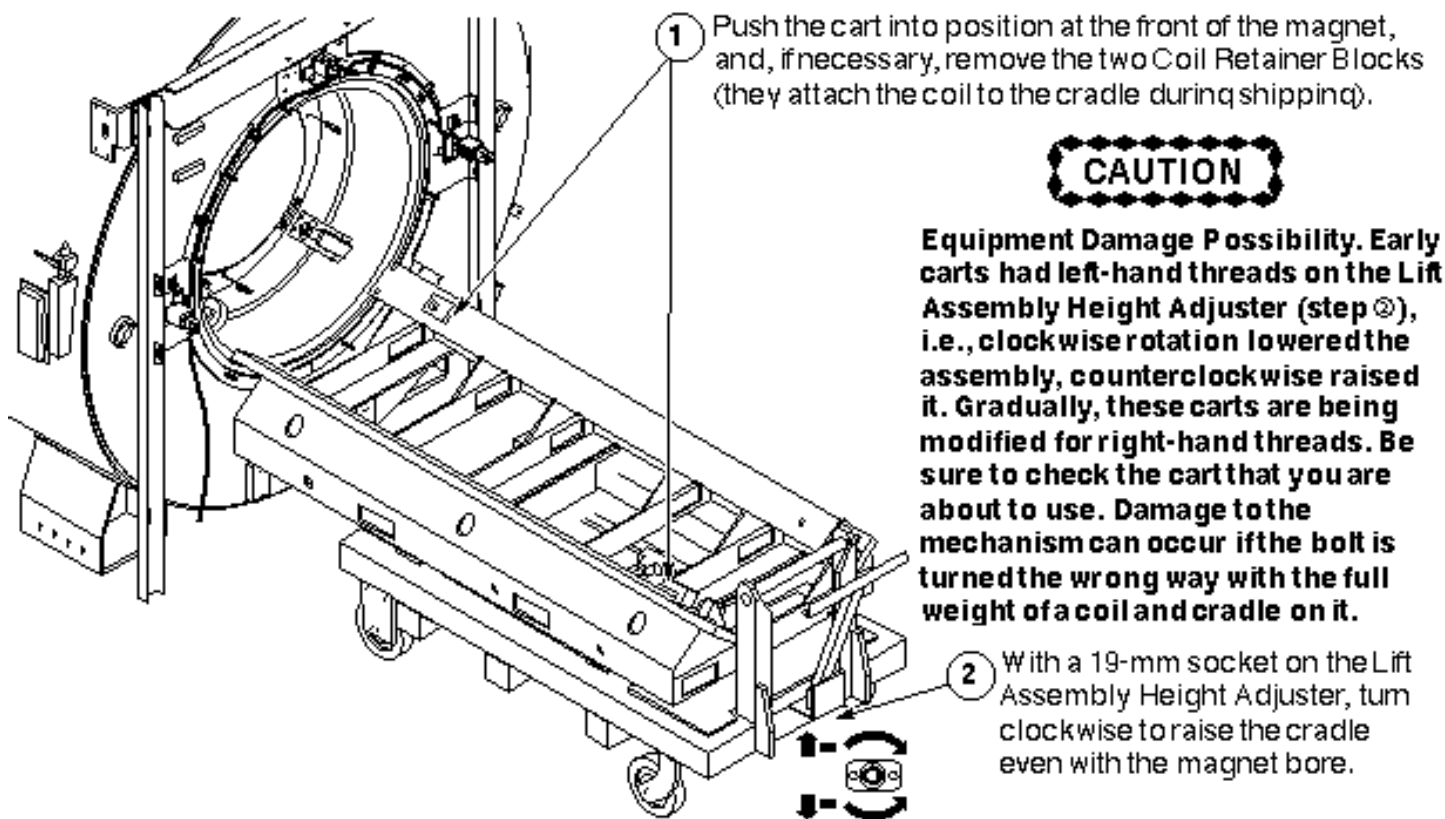

POSITIONING THE EMPTY CRADLE AND CART  
ILLUSTRATION 7-8

### 7-3 Coil Replacement in Mobile Sites

#### 7-3-1 Overview

There are several possibilities for changing the gradient body coil in the various mobile configurations, and all differ significantly from fixed sites. The standard, or *true*, mobile van, and the European version, called the *Eurovan*, both require the coil to be replaced via the rear door. It would be ideal to make the change with the trailer backed up to a loading dock, to avoid dealing with the rear steps of the van.

Gradient body coils in transportables and relocatables must be replaced via the overhead side door, but the floor must be temporarily reinforced with 3/4-inch plywood; only the floor immediately below the magnet is strong enough to support the combined weight of the coil/cradle/cart combination. The patient lift in transportables also cannot support that combination, so a lift truck must be used to place it inside the side door.

In some standard mobile vans (including Calumet Coach), the coil/cradle/cart combination can be wheeled through the rear door. In others, including Ellis & Watts and the Eurovans, it cannot; a lift truck is needed to lift the replacement coil/cradle through the door. The limited space behind the magnet might make positioning the cart difficult, especially if you are not at a loading dock; therefore, it may be easier, in every instance, to skip using the cart, and just have the lift truck place the coil and cradle into the van.

The dimensions to use as a guideline for whether or not to use the cart are: total length of coil on cradle is 84 inches (2134 mm); total length of coil and cradle resting on the cart is 94.5 inches (2400 mm). For additional dimensions, see Illustration 7-9.

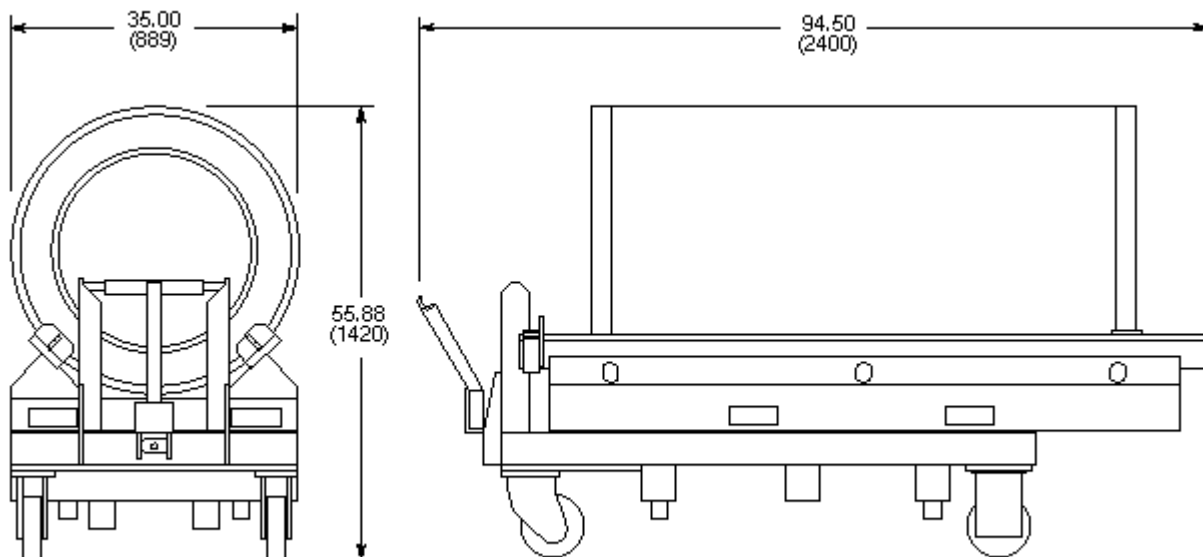

**GRADIENT COIL, CRADLE, AND CART DIMENSIONS**  
ILLUSTRATION 7-9

The following procedure assumes that the gradient coil is situated in a van where the cart cannot be wheeled through the rear door, and, therefore, must be placed by the lift truck. The procedure further assumes that the failed coil has been completely disconnected, and that, if the RF body coil is still operational, it has been removed and set aside.

### 7-3-2 Removing the Failed Gradient Body Coil

The fork lift truck that is used for this procedure should be rated for 6000 pounds (2700 kg), and should be capable of lateral movement of the forks; left to right, as well as forward and reverse. It should also be able to tilt the forks up and down (all for the ease of getting the replacement coil properly aligned for movement into the bore).

### 7-3-3 Prepare Lift Truck Aid

It will be easier for the lift truck driver, and more efficient for the whole operation, if you stack some wood right up against the rear face of the magnet. This provides a place for the driver to rest the far end of the crate (still on the forks, of course!).

It takes whatever wood is on hand to make 30-inch long (minimum) pieces that can be horizontally stacked to a height of approximately 21 inches. Two pieces of 8x8 wood, and three pieces of 2x6 or 2x4 wood come quite close. See Illustration 7-10.

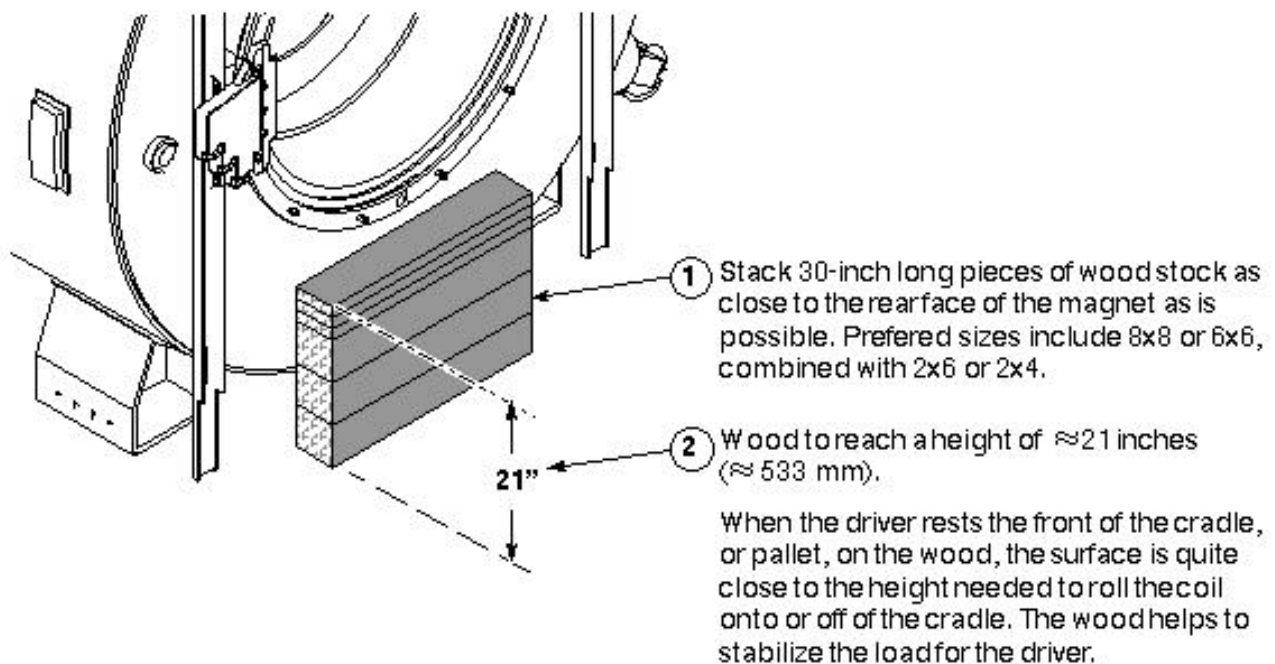

#### STACK WOOD TO SUPPORT COIL & CRADLE

ILLUSTRATION 7-10

When the driver rests the front edge of the cradle, or wooden pallet, on the wood, the surface of the cradle or pallet that the coil rests on should be very close to the correct height for moving coils in and out of the bore. The wood helps stabilize the far end of the forks and their load.

### 7-3-4 Picking up the Load

1. Illustration 7-11 shows the differences in changing gradient coils in a mobile:
  - Forks are placed in end slots of cradle or pallet (rather than crosswise).
  - The six gradient leads are always loaded closest to the driver (remember, you are working at the rear of the magnet).
  - The Coil Retainer Blocks get moved to the end of the cradle closest to the driver.

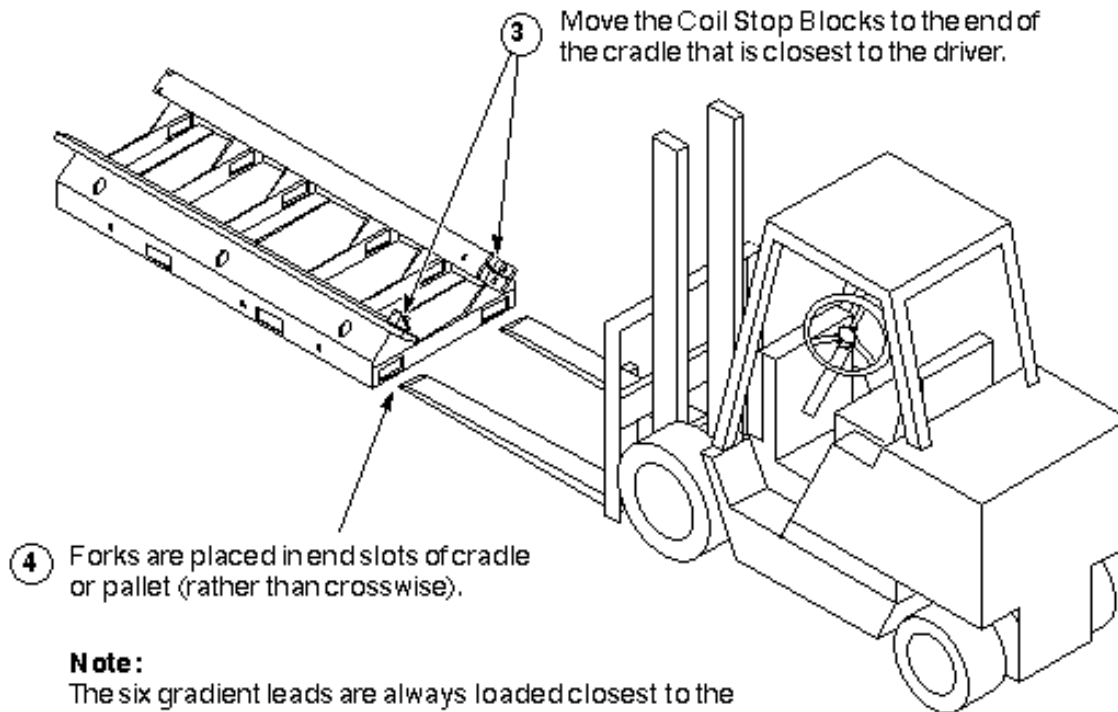

**LIFT DRIVER GETS EMPTY CRADLE**  
ILLUSTRATION 7-11

2. Empty Cradle Supported by Wood Stack.

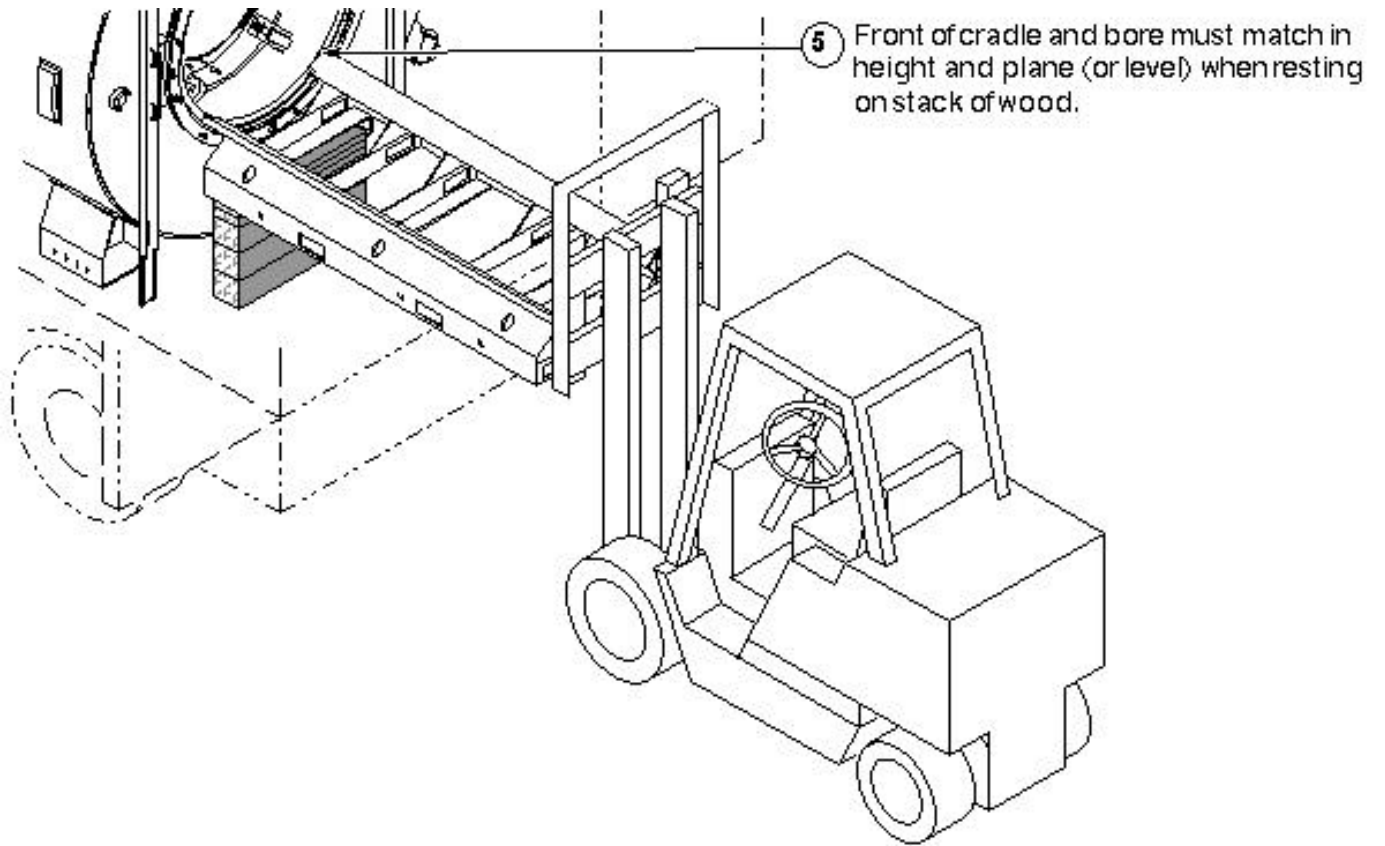

**EMPTY CRADLE SUPPORTED BY WOOD STACK**  
ILLUSTRATION 7-12

3. Failed Coil Rolled Onto Cradle

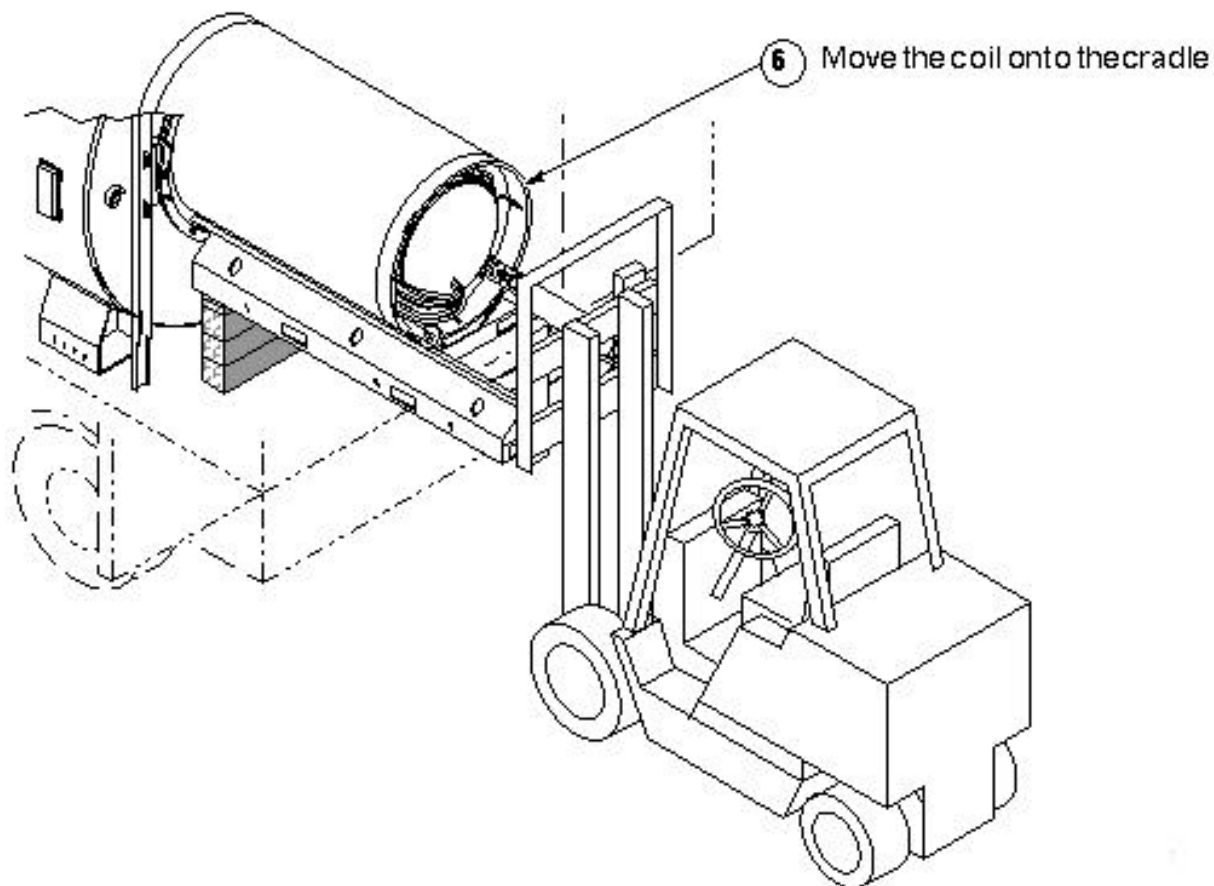

**FAILED COIL ROLLED ONTO CRADLE**  
ILLUSTRATION 7-13

4. Failed Coil Ready for Return Shipment

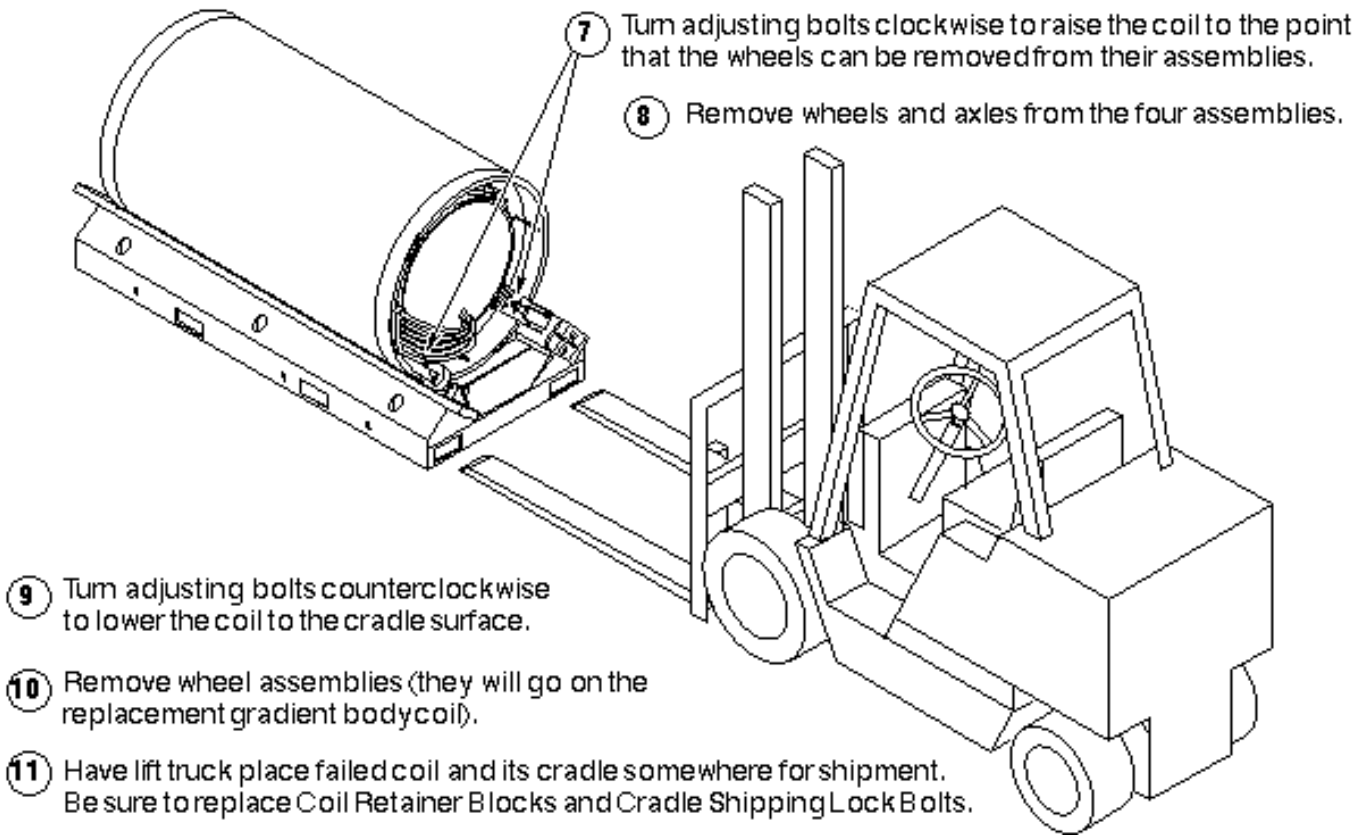

**FAILED COIL READY FOR RETURN SHIPMENT**  
ILLUSTRATION 7-14

## 8- REPLACEMENT COIL INSTALLATION

After having the fork lift truck remove the failed coil and cradle from the cart, the replacement body coil, on its cradle, must be loaded and taken to the scan room.

### For Mobiles

The most difficult part of this procedure is getting the replacement coil correctly aligned so that it rolls easily and completely into the bore. A small carpenter's level is a useful tool to have at this point.

Illustration 8-1 shows replacement coil and cradle loaded lengthwise on forks, with leading edge resting on wood stack.

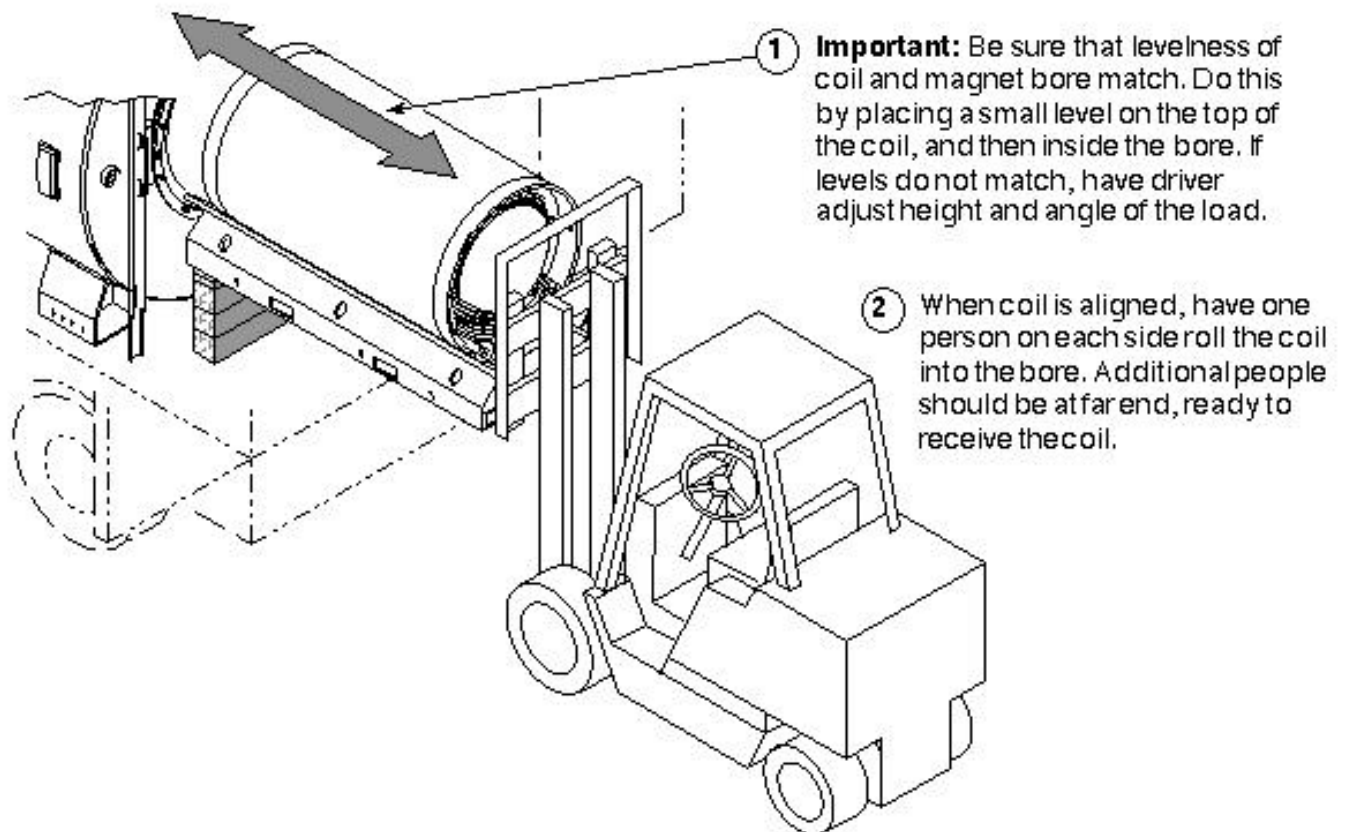

**ALIGN REPLACEMENT COIL & CRADLE WITH BORE**  
ILLUSTRATION 8-1

Once the replacement coil is in the magnet, go to section 8-3 Aligning the Coil in the Bore.

### 8-1 Loading Replacement Coil on Cart

**WARNING!**

**POSSIBLE PERSONAL INJURY AND/OR EQUIPMENT DAMAGE! NOT HAVING THE CRADLE ANCHORED TO THE CART COULD CAUSE THE CRADLE TO TIP WHEN THE COIL MOVES ONTO IT. THE THREE CRADLE ALIGNMENT/LOCK BOLTS MUST BE IN PLACE BEFORE THE COIL IS ROLLED ONTO THE CART.**

#### 1. Loading Replacement Coil/Cradle on Cart

- 1 Have the fork lift raise the replacement coil/cradle combination.

Note - Gradient lead placement

- 2 Position the empty cart beneath the raised cradle so that the Cradle/Alignment Lock Pins are aligned with their holes in the cradle.

**WARNING!**

**POSSIBLE PERSONAL INJURY AND EQUIPMENT DAMAGE! NOT HAVING THE CRADLE ANCHORED TO THE CART COULD CAUSE THE COIL/CRADLE TO TIP. THE THREE CRADLE ALIGNMENT/LOCK BOLTS MUST BE IN PLACE BEFORE THE COIL IS ROLLED ONTO THE CART.**

- 3 Insert the three Cradle Alignment/Lock Bolts.
- 4 Roll cart/cradle into scanroom.

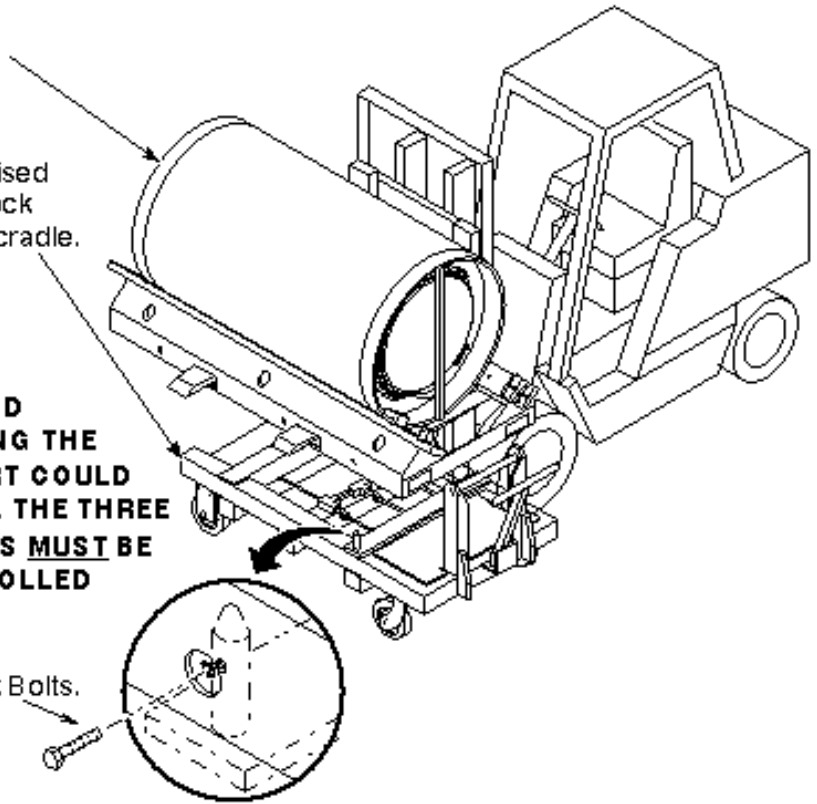

LOADING REPLACEMENT COIL/CRADLE ON CART  
ILLUSTRATION 8-2

### 8-2 Moving Coil into Magnet

#### 1. Positioning Replacement Coil at Magnet

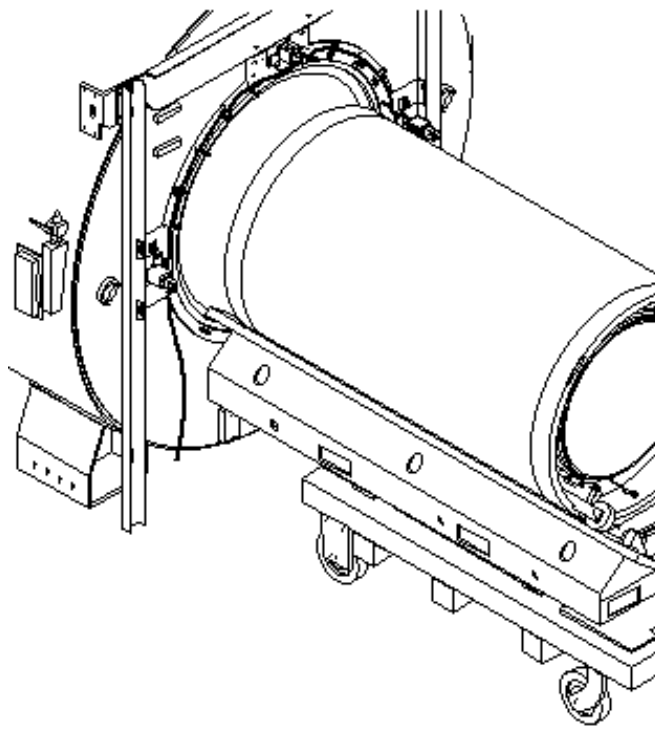

① Position cart near front of magnet enclosure.

② Remove Coil Retainer Blocks.

③ Install Roller Wheel Assemblies. Refer back to the steps in this illustration (if necessary):

Illustration 7-6 - installing Roller Wheel Assemblies.

④ Push cart into final position at the front of the magnet.

⑤ Turn Lift Assembly Height Adjuster clockwise to raise the coil/cradle even with the magnet bore.

**POSITIONING REPLACEMENT COIL AT MAGNET**  
ILLUSTRATION 8-3

2. Installing Replacement Coil

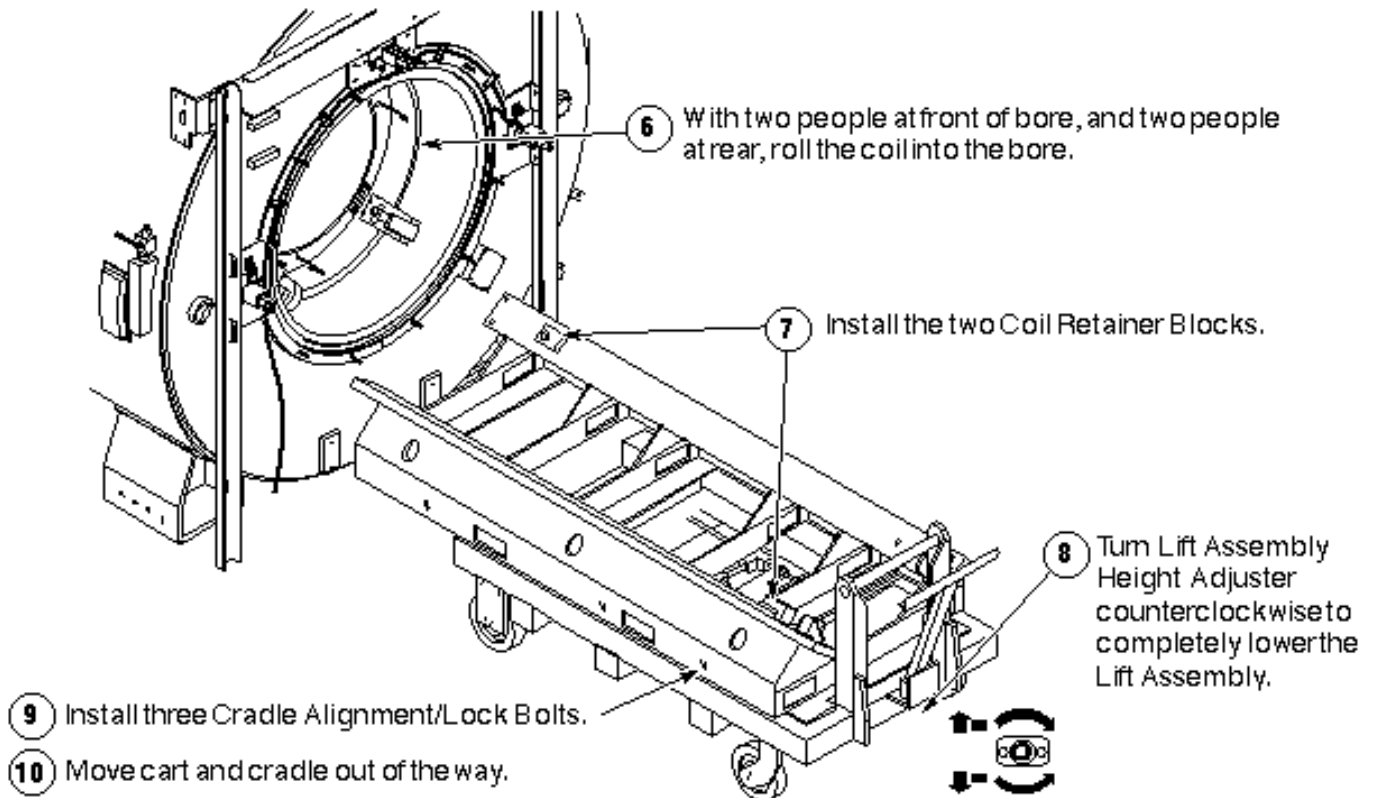

**INSTALLING REPLACEMENT COIL**  
ILLUSTRATION 8-4

3. Mounting the Roller Wheel Assemblies

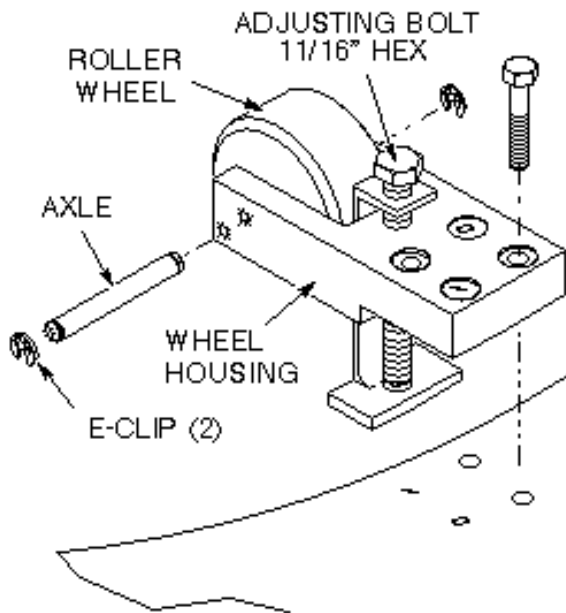

- 1 From the accessory kit, get the four Roller Wheel Assemblies (212111), and M10x50 bolts, for mounting to the coil, two at each end.
- 2 Back the adjusting bolt all the way out by turning it counterclockwise.
- 3 With a non-magnetic screwdriver, remove one of the e-clips, and remove wheel and axle from each housing.
- 4 Place each Wheel Housing in position over the four threaded holes on the coil and fasten with four bolts.
- 5 Turn the adjusting bolt clockwise on all four Roller Wheel Assemblies to raise the coil to the point that the wheels and axles can be installed.
- 6 Note in which position to install wheels and axles.

Use upper hole for GE magnets with passive or resistive shim.

Use lower hole for magnets without passive or resistive shim.

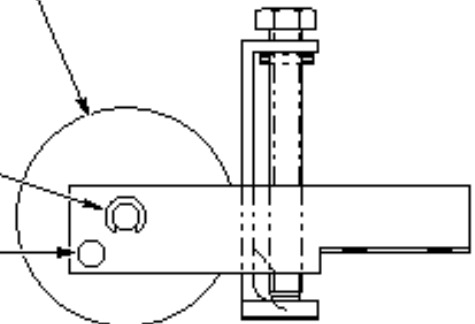

**MOUNTING THE ROLLER WHEEL ASSEMBLIES**  
ILLUSTRATION 8-5

### 8-3 Aligning the Coil in the Bore

Once the replacement coil is in the bore, it must be aligned along the x, y, and z axes.

1. Aligning the coil along the z-axis. See Illustration 8-6 for the BRM Coil or Illustration 8-7 for the CRM Coil.

- 1 The front edge of coil must be twelve inches inside the face of the enclosure for coil to be at isocenter along the z-axis (lengthwise).

Position coil inside magnet bore within the required tolerances.

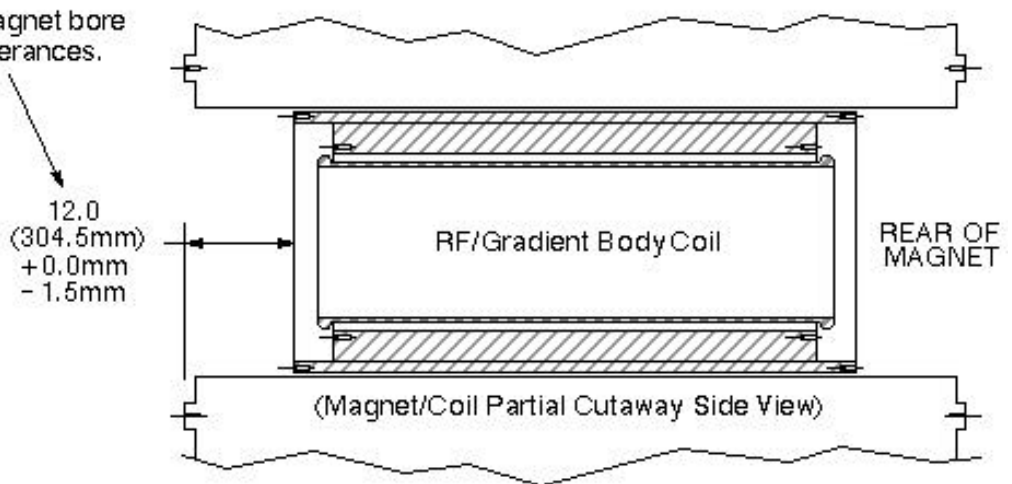

**ALIGNING BRM COIL ALONG THE Z-AXIS**  
ILLUSTRATION 8-6

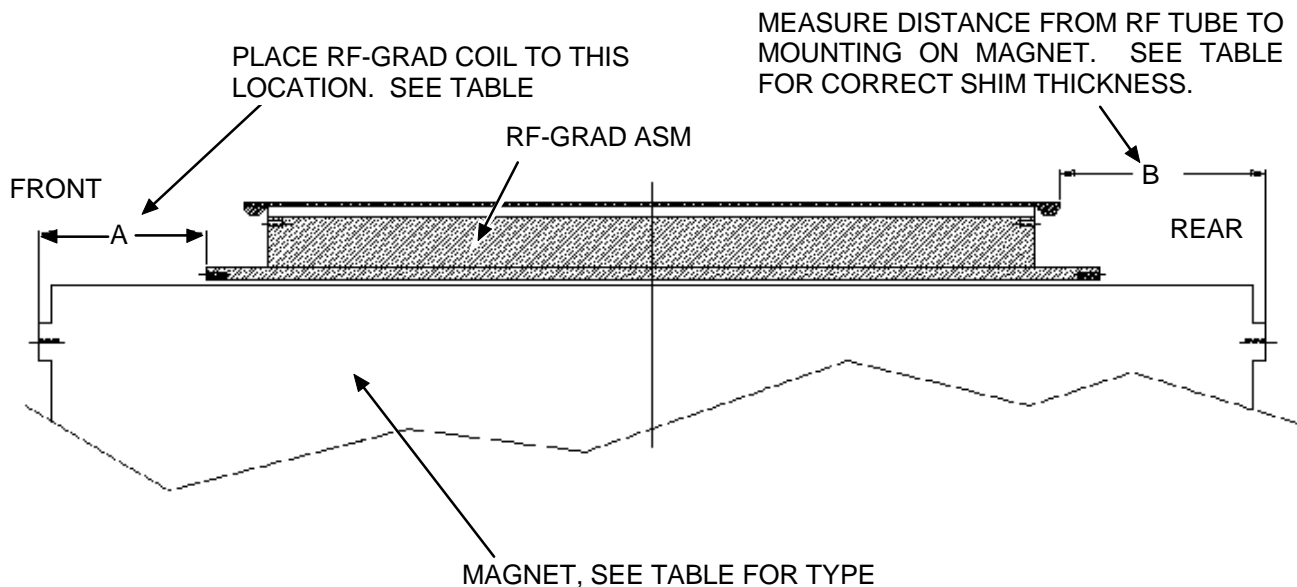

**ALIGNING CRM COIL ALONG THE Z-AXIS**  
ILLUSTRATION 8-7

TABLE 8-1  
COIL ALIGNMENT

Coil Type →	BRM ALL MAGNETS 1.0T AND 1.5T ONLY				CRM			
	S1	Oxford	S2 S3 S4 W.B.	S2 S3 S4 W.B.				
Magnet Type →								
Magnet Length NOM. REF. MTG Flange to MTG Flange	21900.8 MM (86.25 IN)	2290.1 MM (90.16 IN)	2228.9 MM (87.75 IN)	2228.9 MM (87.75 IN)				
A BRM distance to FRT Magnet Face	+0.0 285.5 MM -1.5 (11.24 IN)	+0.0 335.0 MM -1.5 (13.18 IN)	+0.0 304.5 MM -1.5 (12.00 IN)	+0.0 264.5 MM -1.5 (10.43 IN)				
Front Rubber Shims Needed	22.0 MM (0.87 IN)	1.50 MM (0.6 IN)	1.50 MM (0.6 IN)	1.50 MM (0.06 IN)				
B RF Tube Distance to Rear Magnet Face	Measure in MM	Measure in MM	Measure in MM	Measure in MM				
Rear Rubber Shims Needed	393.0 - B MM	417.0 - B MM	393.0 - B MM	583.0 - B MM				

2. Aligning the coil along the x-axis

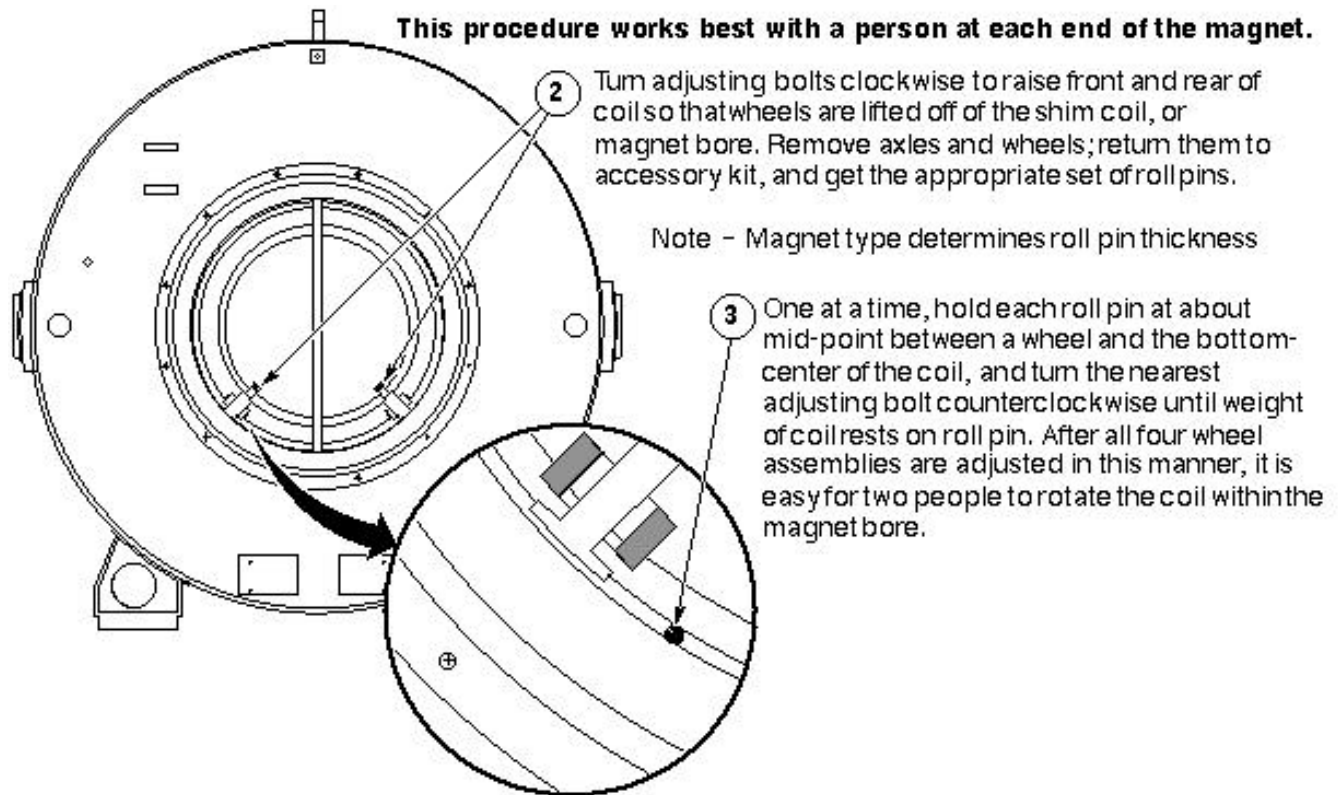

ALIGNING THE COIL ALONG THE X-AXIS  
ILLUSTRATION 8-7

The replacement gradient coil is now completely installed. At this point, you may follow either of two procedures:

- If the RF Body Coil was removed for later installation in the replacement gradient body coil, perform the procedure to install RF coil below,

**OR**

- If the RF Body Coil was replaced along with the gradient coil, go on to the following section 8-4.

### 8-3-1 Install RF Coil

1. Install Tracks in Replacement Gradient Coil

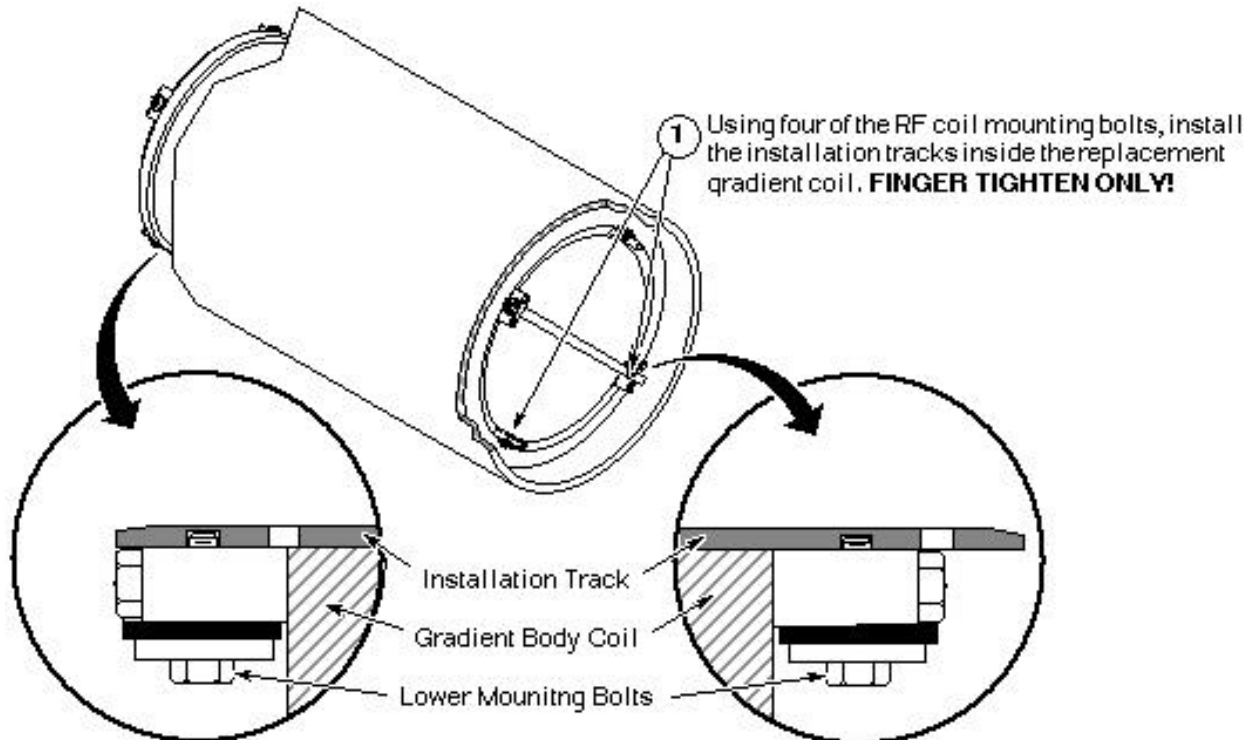

**INSTALL TRACKS IN REPLACEMENT GRADIENT COIL**  
ILLUSTRATION 8-8

2. Install RF Coil in Gradient Coil

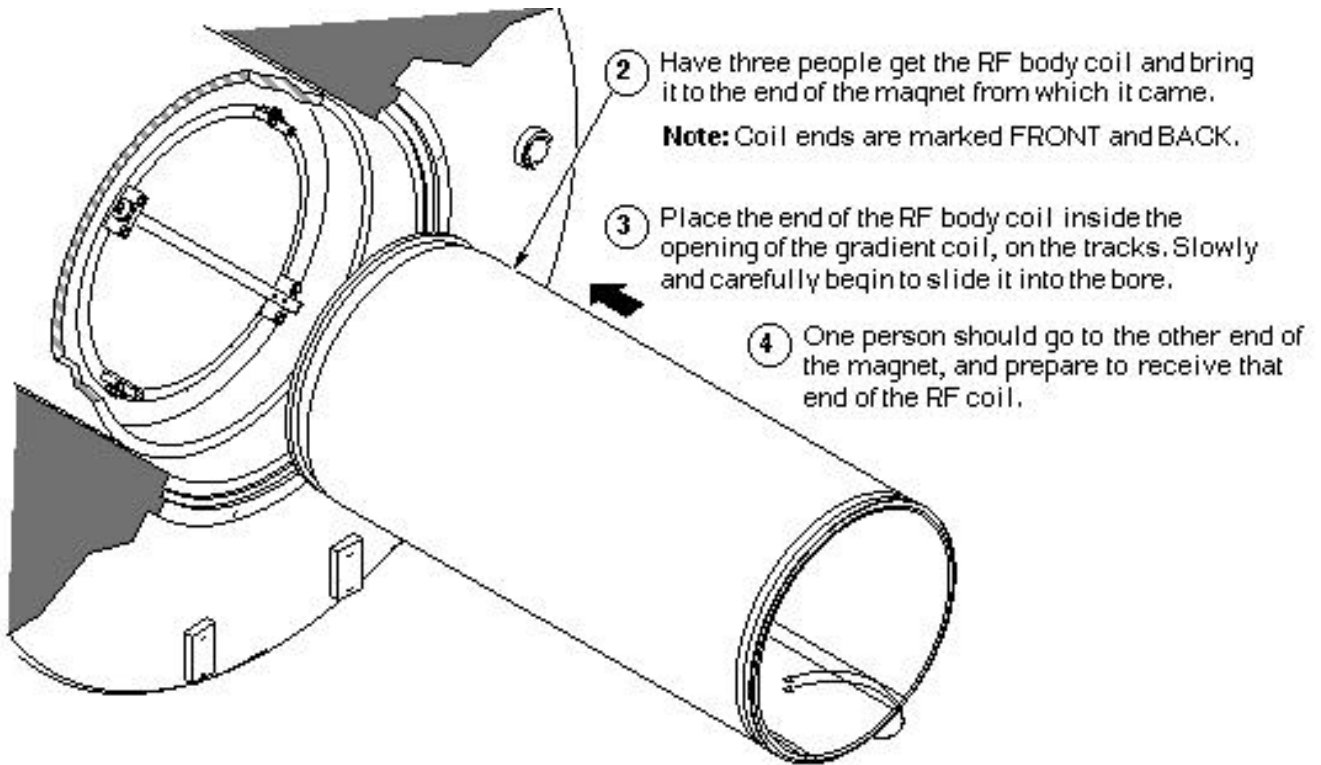

INSTALL RF COIL IN GRADIENT COIL  
ILLUSTRATION 8-9

3. Securing RF Coil in Gradient Coil

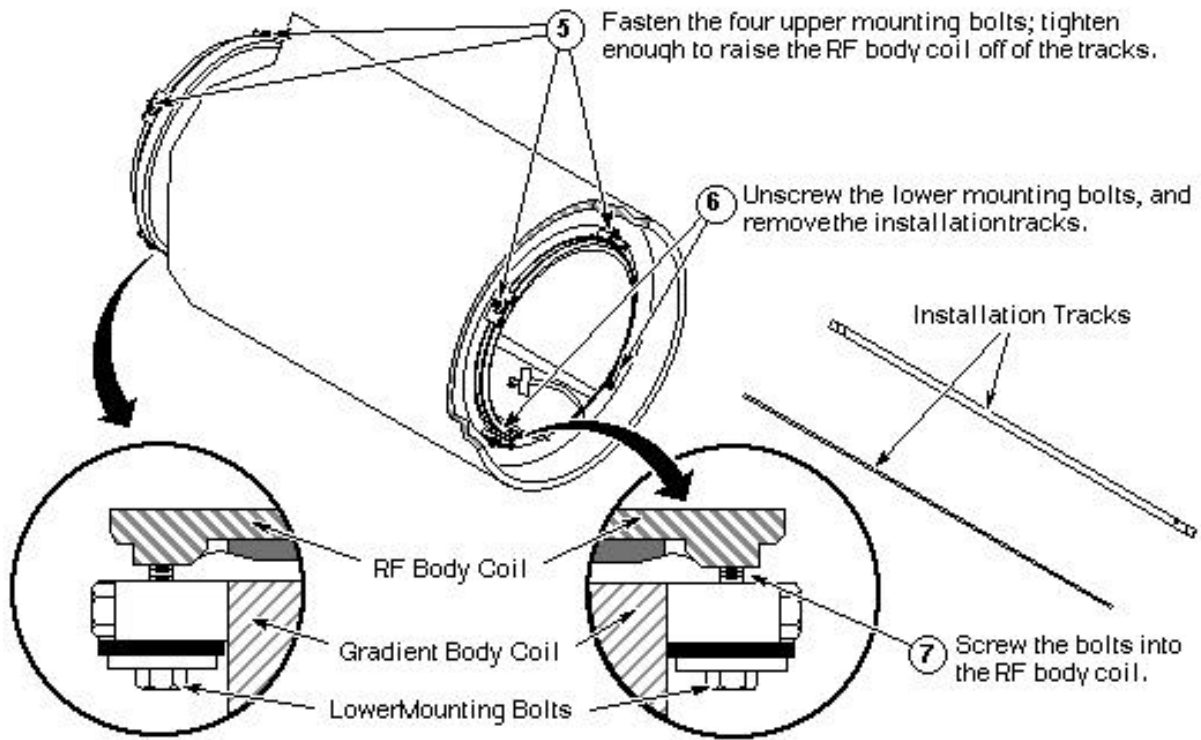

**SECURING RF COIL IN GRADIENT COIL**  
ILLUSTRATION 8-9

4. Centering RF Coil in Gradient Coil

RF body coil must be centered within the gradient body coil.

- ① As indicated below, measure in four places the distance between the inside surface of the outer gradient coil cylinder and the inner bore of the RF body coil.
- ② If needed, turn any or all of the eight mounting bolts to adjust the location of the RF body coil so it is centered within the gradient coil.

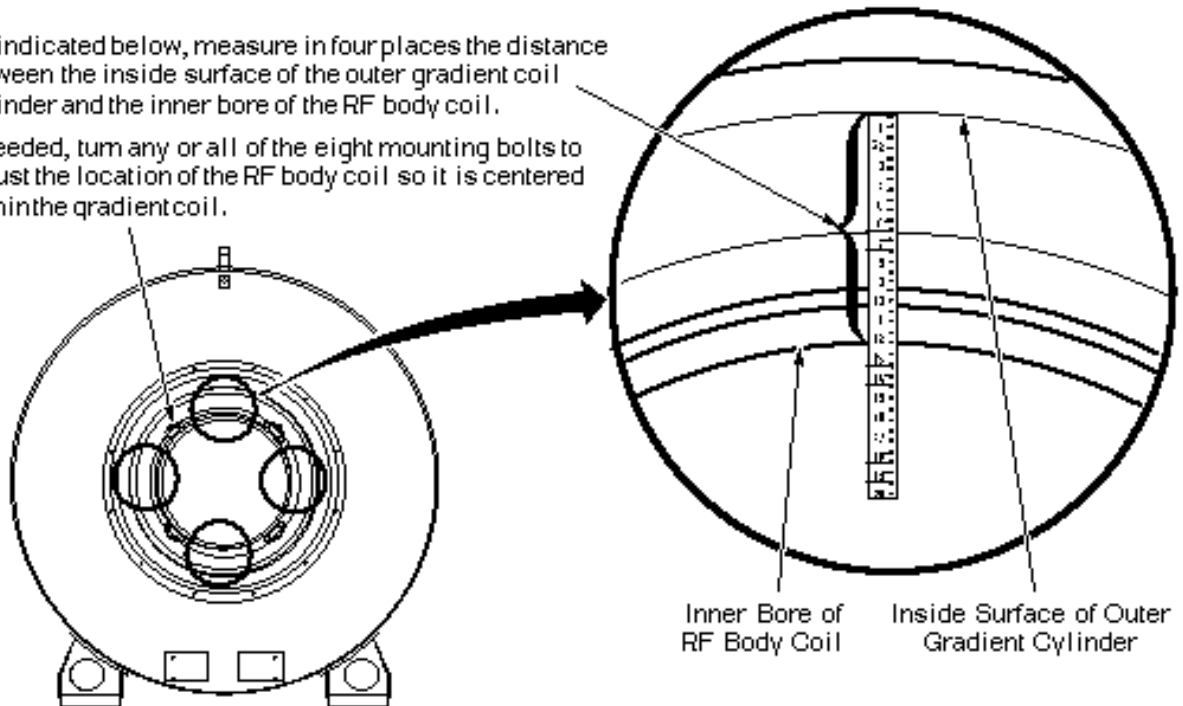

**CENTERING RF COIL IN GRADIENT COIL**  
ILLUSTRATION 8-10

### 8-4 Connecting Replacement Coil

#### 1. Reconnect Cooling Hoses, Acoustic Collar, and Power

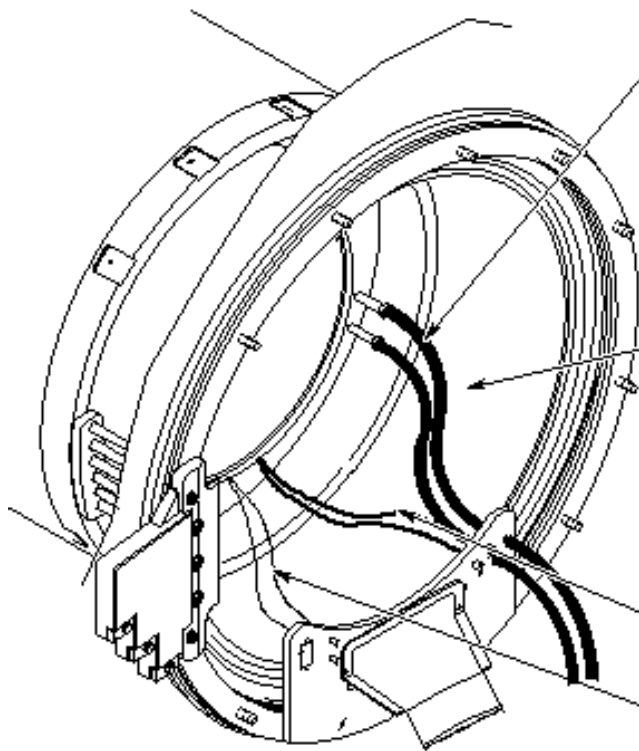

1 Remove temporary connectors from cooling hoses and reconnect to coil.

**Note:** There will be less chance of coolant spillage if two people, rather than one, reconnect the hoses.

**Note:** In mobiles, where bulkhead has been removed from end ring, but still has hoses running through it, reconnect hoses to coil before reattaching the bulkhead.

2 Replace rear acoustic collar.

**CAUTION**

**Possible equipment damage. When moving body coil drive cables (usually colored blue), handle them with care. Do not kink them, nor bend them sharply; damage can occur.**

3 Connect as marked body coil drive cables to J1 and J2 on bulkhead. Handle them carefully!

4 Connect as marked DD bias cables to J5 and J6 on bulkhead.

RECONNECT COOLING HOSES, ACOUSTIC COLLAR, AND POWER  
ILLUSTRATION 8-11

2. Reinstall Rear Pedestal (in Mobiles only)

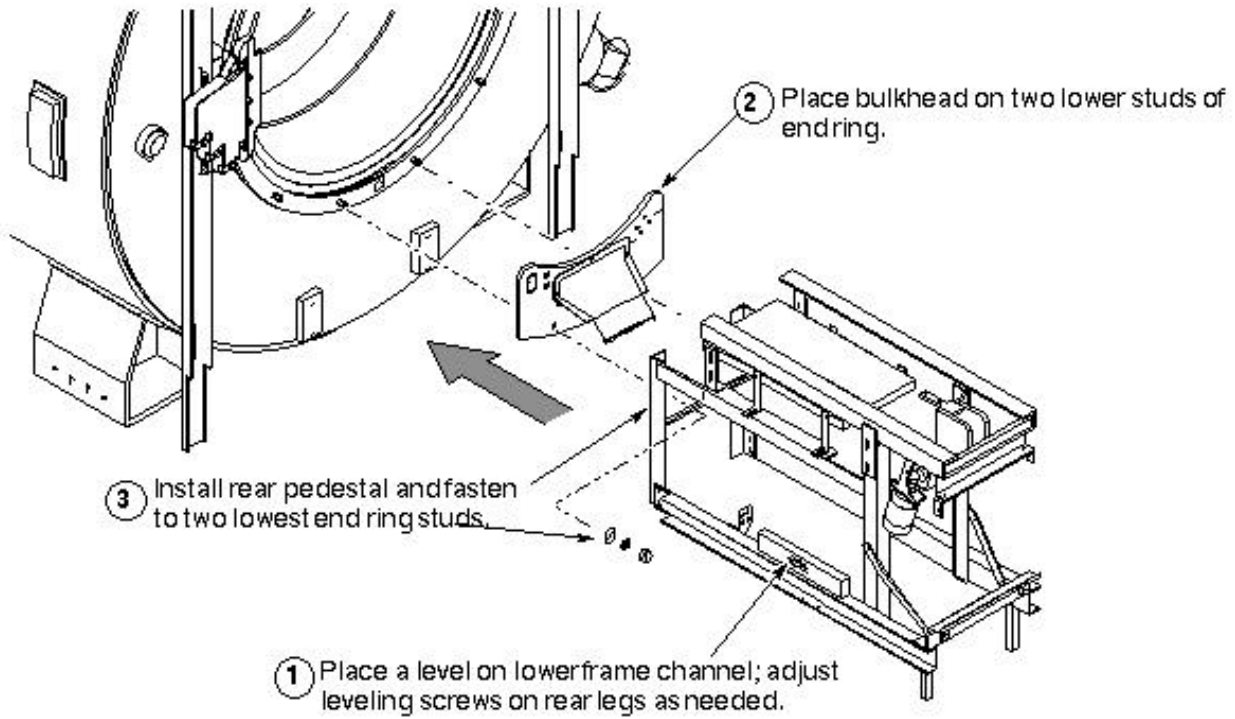

**REINSTALL REAR PEDESTAL (IN MOBILES ONLY)**  
ILLUSTRATION 8-12

## 9- REAR END BELL REPLACEMENT

### 1. Replace Rear End Bell

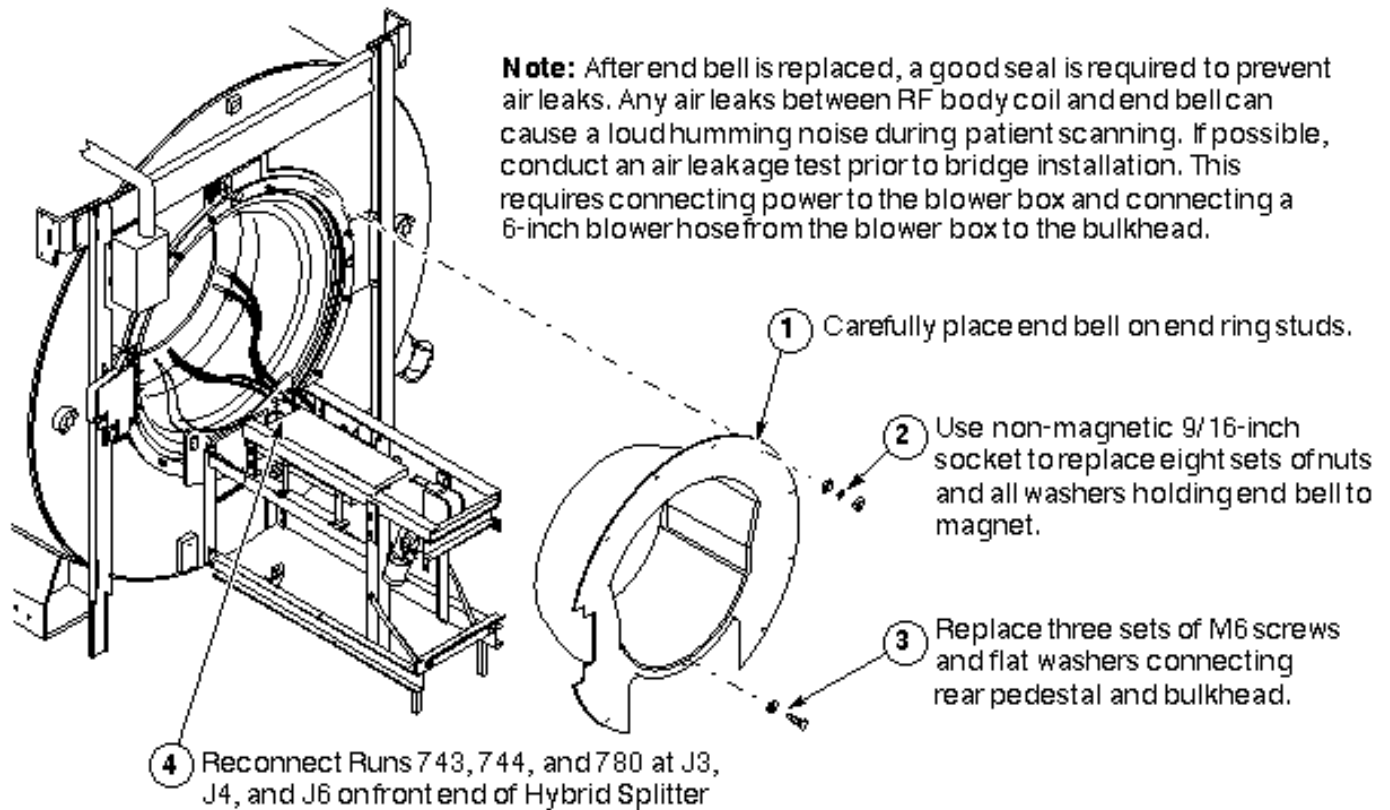

**REPLACE REAR END BELL**  
ILLUSTRATION 9-1

2. Reconnect gradient leads.

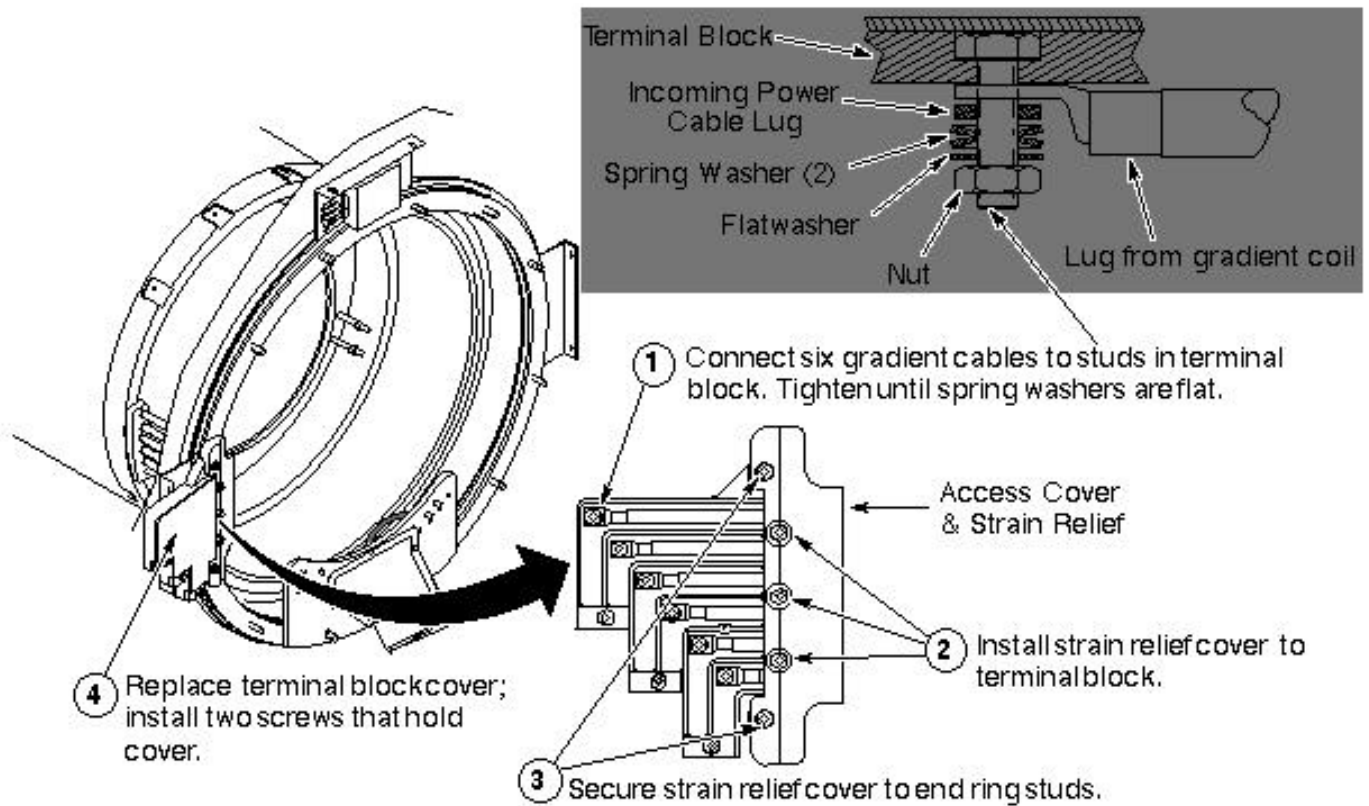

**RECONNECT GRADIENT LEADS**  
ILLUSTRATION 9-2

**Note**

Reconnecting six gradient leads - When replacing the six gradient cables from the coil on the terminal block, be sure that they go on the stud first, followed by the incoming power cables, washers, and nuts.

3. Replace rear comfort items

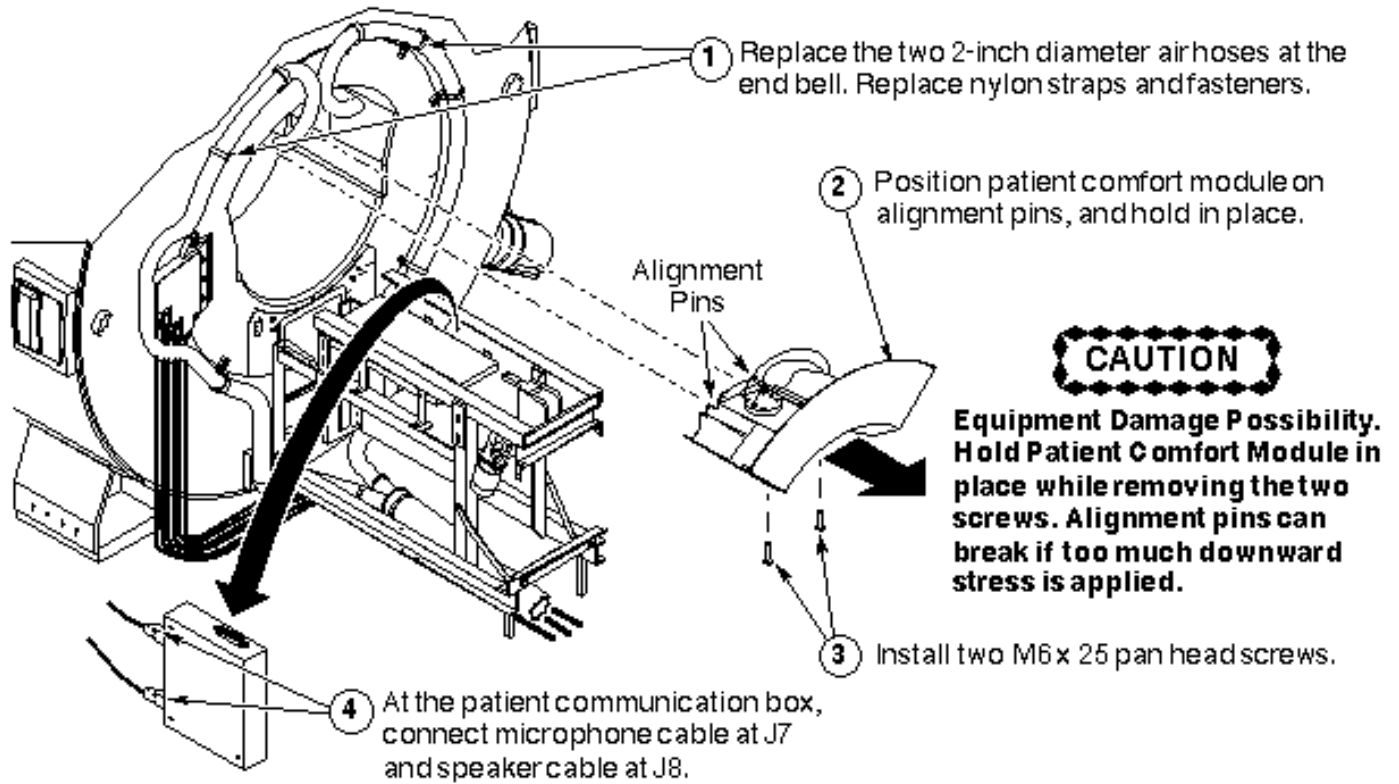

REPLACE REAR COMFORT ITEMS  
ILLUSTRATION 9-3

### 10- FRONT END BELL REPLACEMENT

1. Replace front end bell

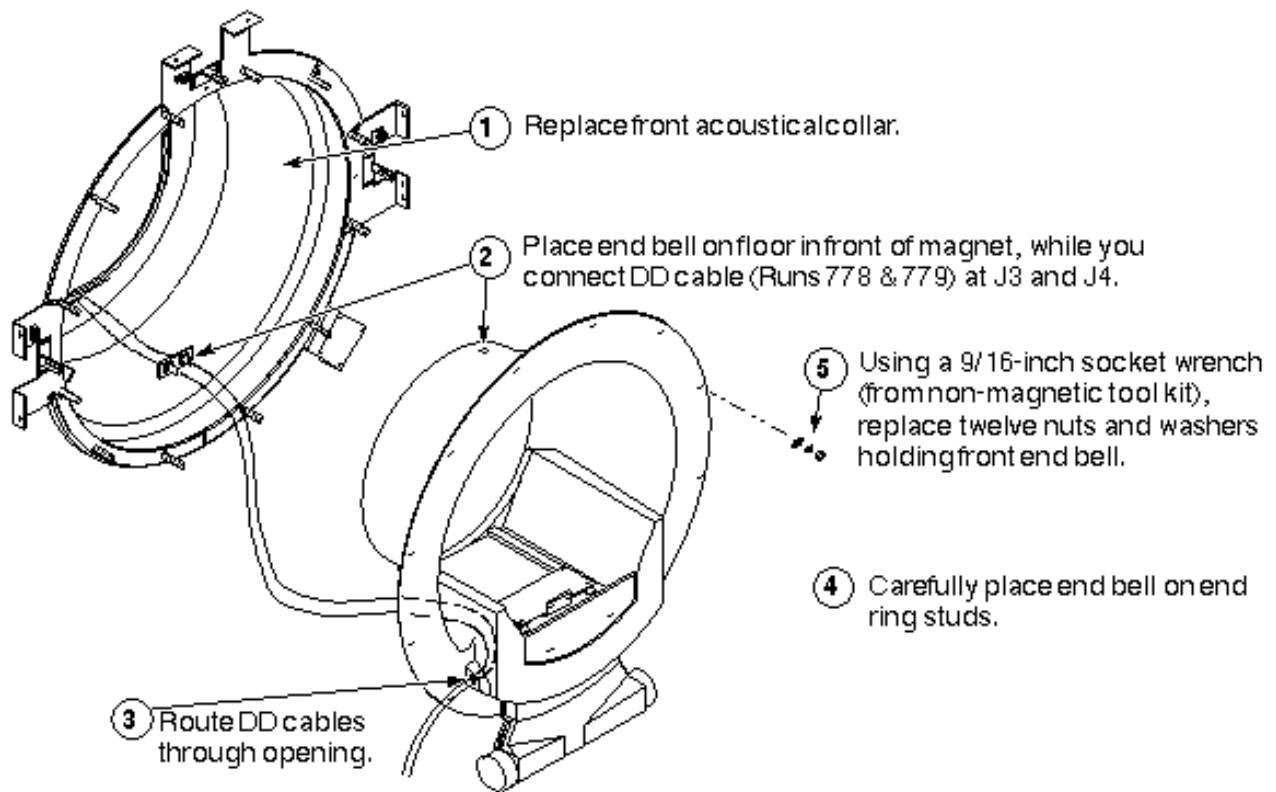

**REPLACE FRONT END BELL**  
ILLUSTRATION 10-1

2. Replace front comfort items

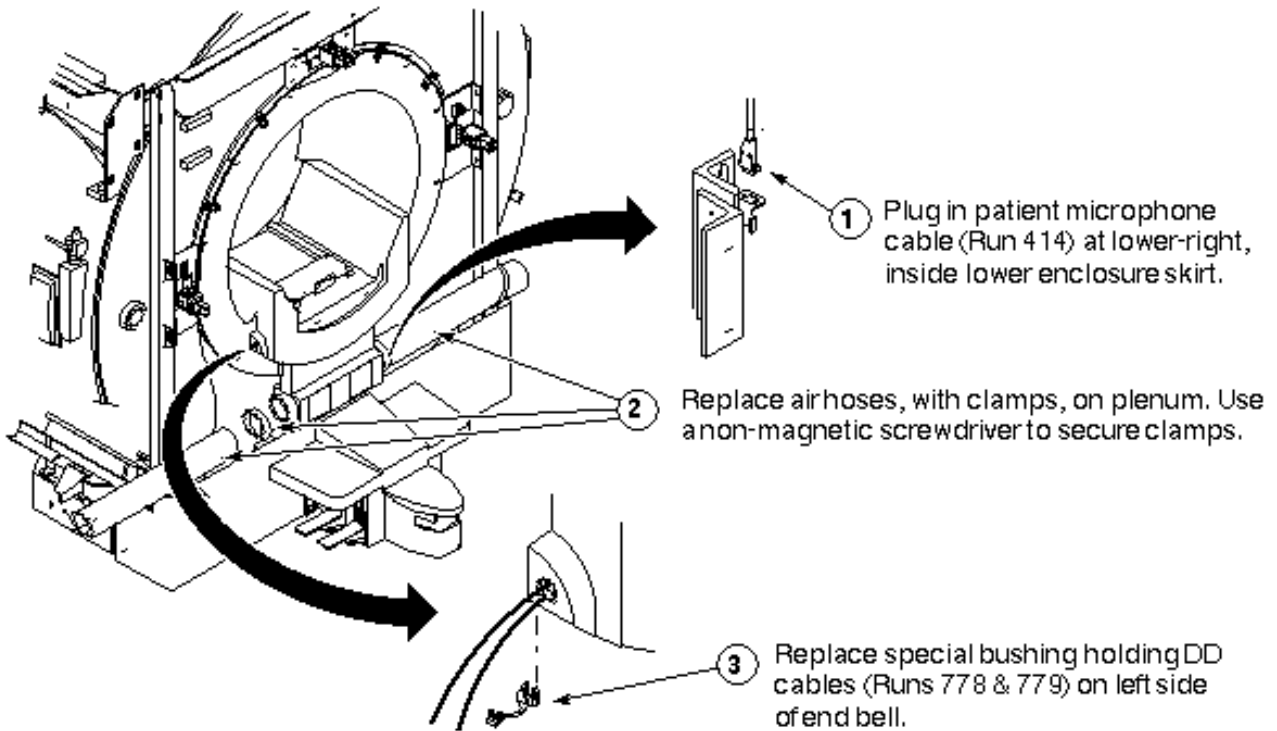

**REPLACE FRONT COMFORT ITEMS**  
ILLUSTRATION 10-2

### 11- BRIDGE REPLACEMENT

Perform the procedure depicted below,

**OR**

Perform procedure Patient Handling, Bridge Replacement.

#### 1. Reinstalling Bridge (steps 1-3)

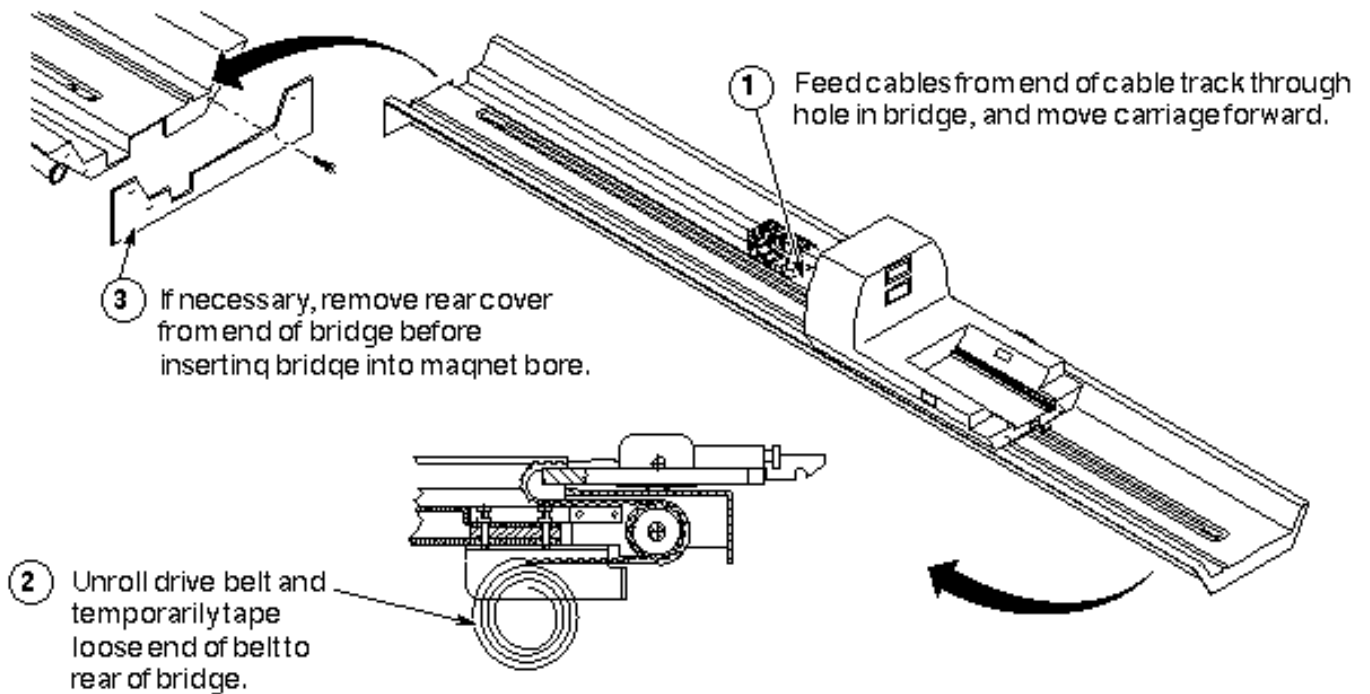

**REINSTALLING BRIDGE (STEPS 1-3)**  
ILLUSTRATION 11-1

2. Reinstalling Bridge: steps 4-7

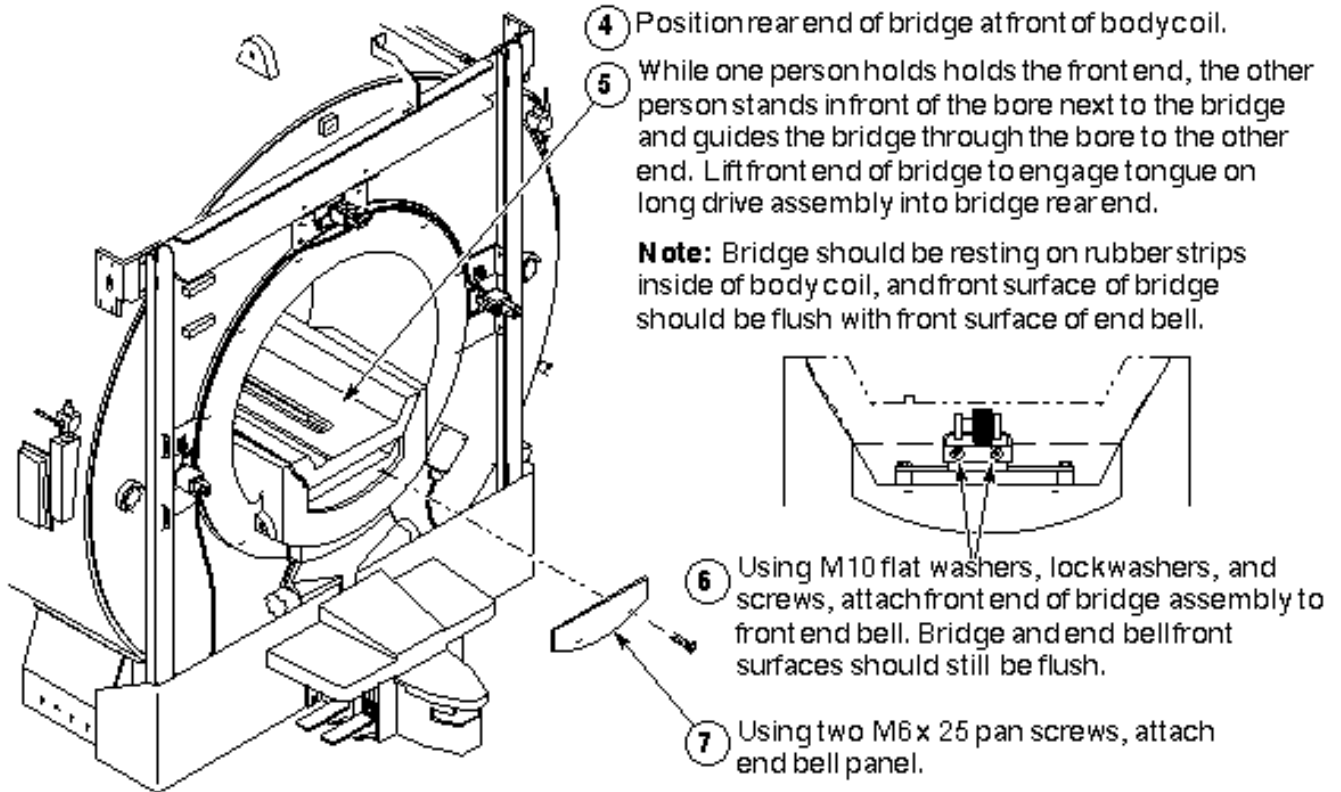

REINSTALLING BRIDGE: STEPS 4-7  
ILLUSTRATION 11-2

3. Reinstalling Bridge: steps 8–14

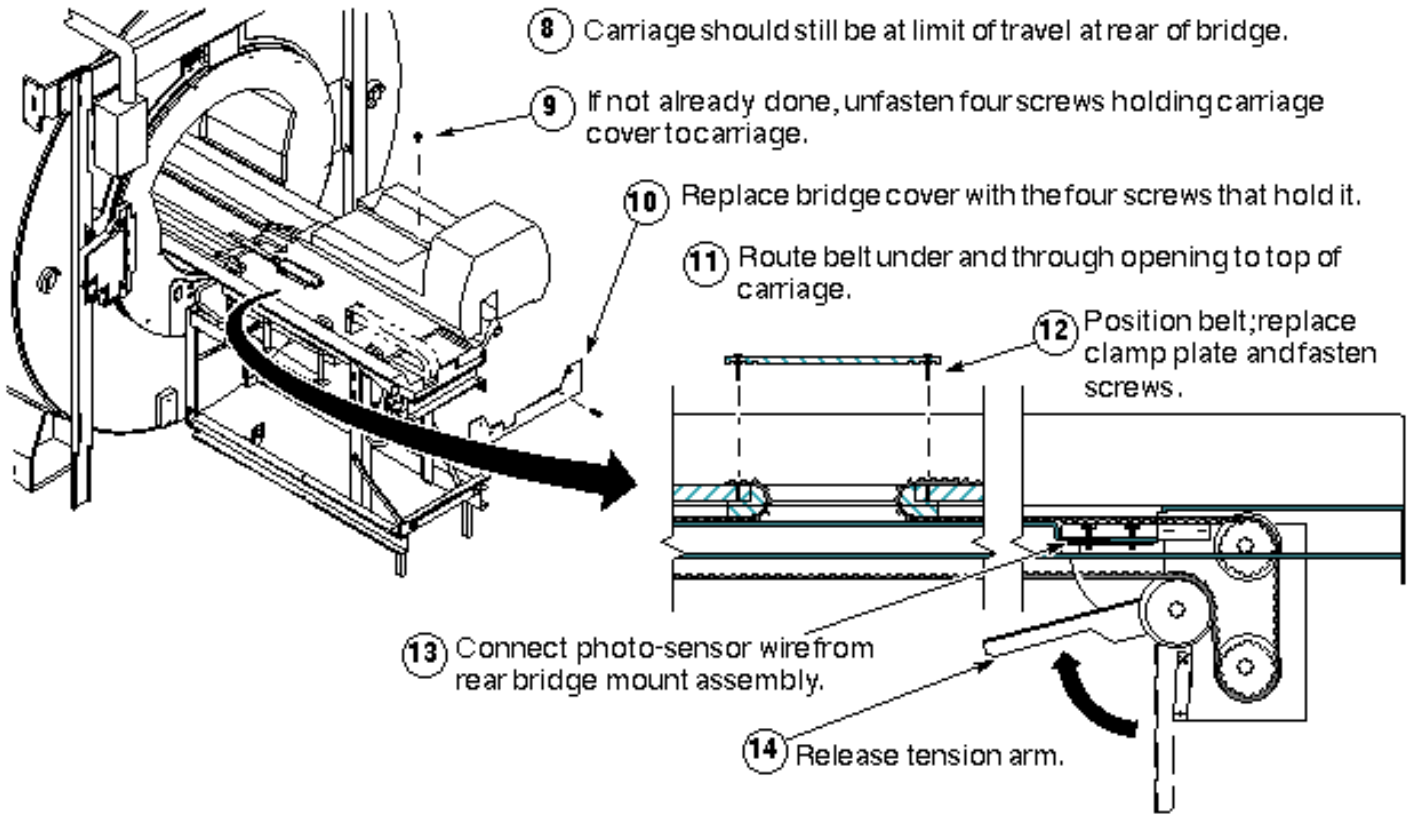

**REINSTALLING BRIDGE: STEPS 8–14**  
ILLUSTRATION 11-3

4. Reinstalling Bridge: steps 15–18

**16 (If necessary):**  
Loosen clamp and adjust position of belt one tooth at a time until desired tension is obtained.

**17** Tighten clamp screws and, if necessary, trim excess belt length.

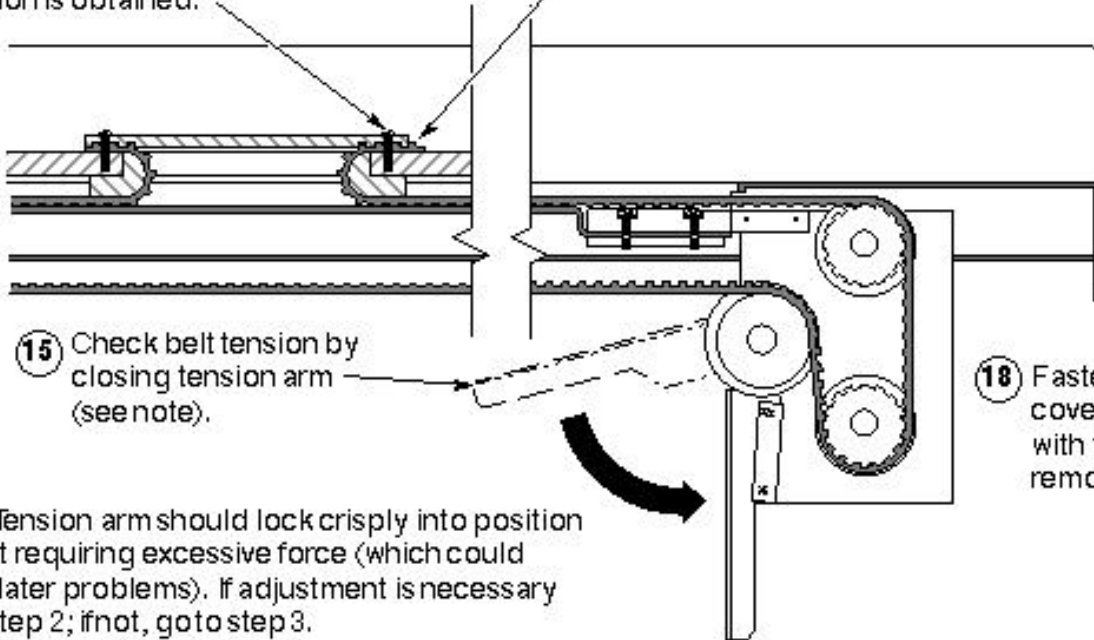

**15** Check belt tension by closing tension arm (see note).

**18** Fasten carriage cover to carriage with four screws removed earlier.

**Note:** Tension arm should lock crisply into position without requiring excessive force (which could cause later problems). If adjustment is necessary go to step 2; if not, go to step 3.

**REINSTALLING BRIDGE: STEPS 15–18**  
ILLUSTRATION 11-4

## 12- ENCLOSURE END COVERS REPLACEMENT

**WARNING!**

**PERSONAL INJURY AND/OR EQUIPMENT DAMAGE POSSIBILITY! FRONT AND REAR ENCLOSURES ARE HEAVY AND CUMBERSOME. AT LEAST TWO PEOPLE ARE REQUIRED TO LIFT AND MOVE THEM; THREE IS PREFERABLE.**

### 1. Reinstall Enclosure End Covers

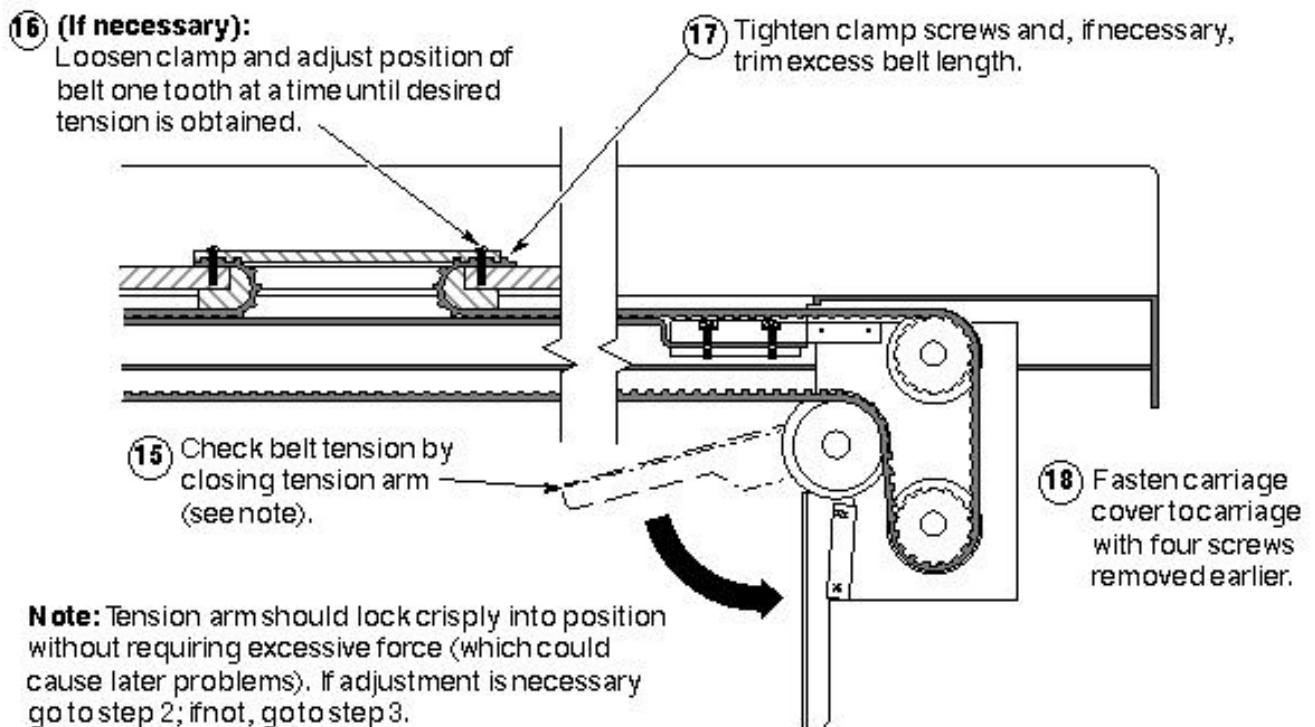

**REINSTALL ENCLOSURE END COVERS**  
ILLUSTRATION 12-1

### 13- SYSTEM RESTORATION

1. Remove the lockout/tagout from MR1 A14 CB6 at the rear of the RF/Pen Cabinet (MR1) on Magnet Power Supply (MEPS) Module.
2. Perform the following tests:
  - Only if you installed a new RF body coil: DD/TR Driver Adjustment
  - Gradcal Test
  - Grafidy (Signa Horizon only; GRAM Tuning on Horizon HiSpeed and EchoSpeed)
  - LVShim
  - Body Spike Noise
  - System Gain

## REVISION HISTORY

REV	DATE	AUTHOR	PRIMARY REASONS FOR CHANGE
0	July 7, 1998	J. Saperstein	Initial conversion from Toolbook to Word.
1	June 24, 1999	K. Keshena	Added CRM Coil Alignment information to section 8-3.