

TABLE OF CONTENTS

TABLE OF CONTENTS	1
DESCRIPTION	2
1- INTRODUCTION	2
2- BIT3 TROUBLESHOOTING FLOWCHART (SYSTEMS WITH FIBER OPTIC MODULES)	3
3- KNOWN BIT3 PROBLEMS	6
4- TROUBLESHOOTING TIPS (SYSTEMS WITH FIBER OPTIC MODULES)	6
4-1 Mouse Locks Up	6
4-2 TPS Reset Error Conditions	7
4-3 Duplicate Fiber Optic Cables	7
4-4 Bit-3 Communication Troubleshooting	7
4-5 Simple Ping Test of The TPS	8
5- TROUBLESHOOTING BIT3 WITH ON-BOARD FIBER-OPTICS (RELEASE 8.3)	10
5-1 Bit3 Diagnostics	10
5-1-1 Full Host/TPS Communication Test.....	12
5-1-2 Host Board Only Test.....	12
5-1-3 Advanced Bit3 Test.....	12
5-1-4 Bit3 Diagnostic from root level.....	14
5-1-5 Bit3 Diagnostic Flowchart	14
6- BIT3 VME BOARD JUMPER SETTINGS	16
APPENDIX A - EXCERPTS FROM SN60922	19
APPENDIX B - TPS CPU MESSAGES (FOR TPS RESET)	22
REVISION HISTORY	25

DESCRIPTION

Bit 3 communication occurs between the SGI Host Computer and the TPS / ISE Chassis. There are many pieces to this system including 2 copper cables, 4 fiber optic cables, 2 Fiber Optic Converter Modules, and two Bit3 cards.

1- INTRODUCTION

Communication errors between the Host Computer and the TPS / ISE Chassis can happen for a variety of reasons. If any of the following components are bad, a communication fault will occur.

Systems with Fiber Optic Modules:

- Bit 3 Board in the OW Cabinet
- Copper Cable from Bit3 Bd to Fiber Optic Module
- Bit 3 Fiber Optic Interface in the OW Cabinet
- Fiber Optic cables between the OW Cabinet and the System Cabinet
- Bit 3 Fiber Optic Interface in the System Cabinet
- Copper Cable from Bit3 Bd to Fiber Optic Module
- Bit 3 Board in the System Cabinet

Systems without Fiber Optic Modules:

- Fiber Optic Bit 3 Board in the OW Cabinet
- Fiber Optic cable between the OW Cabinet and the System Cabinet
- Fiber Optic Bit 3 Board in the System Cabinet

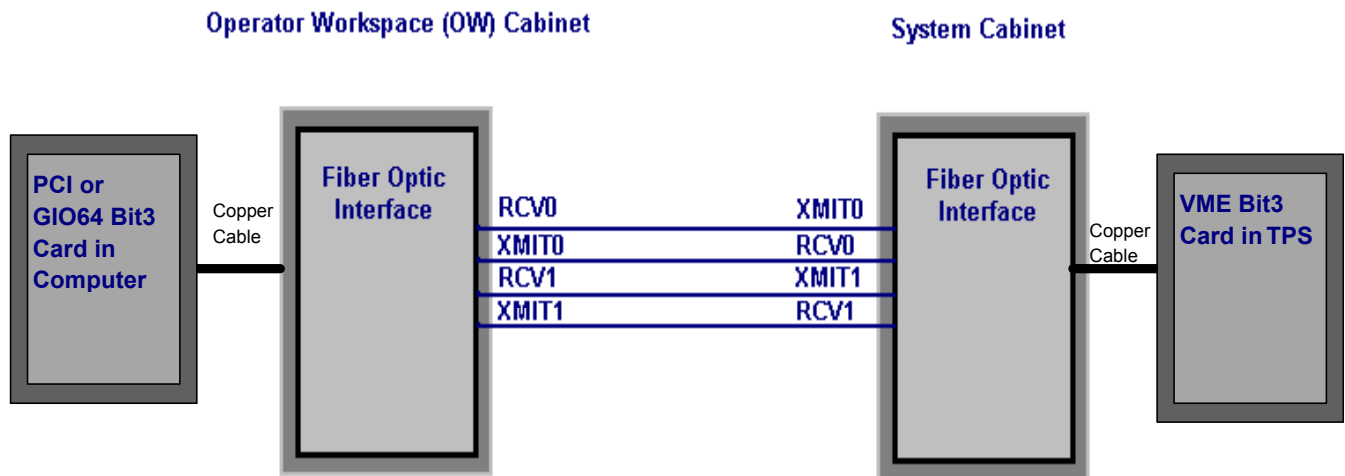

BIT 3 BLOCK DIAGRAM (SYSTEM WITH FIBER OPTIC MODULES SHOWN)
ILLUSTRATION 1-1

2- BIT3 TROUBLESHOOTING FLOWCHART (SYSTEMS WITH FIBER OPTIC MODULES)

An html version of this flowchart can be found on the Service CD ROM under Troubleshooting IPG. <D:\troubsh\ipg\dp.htm>

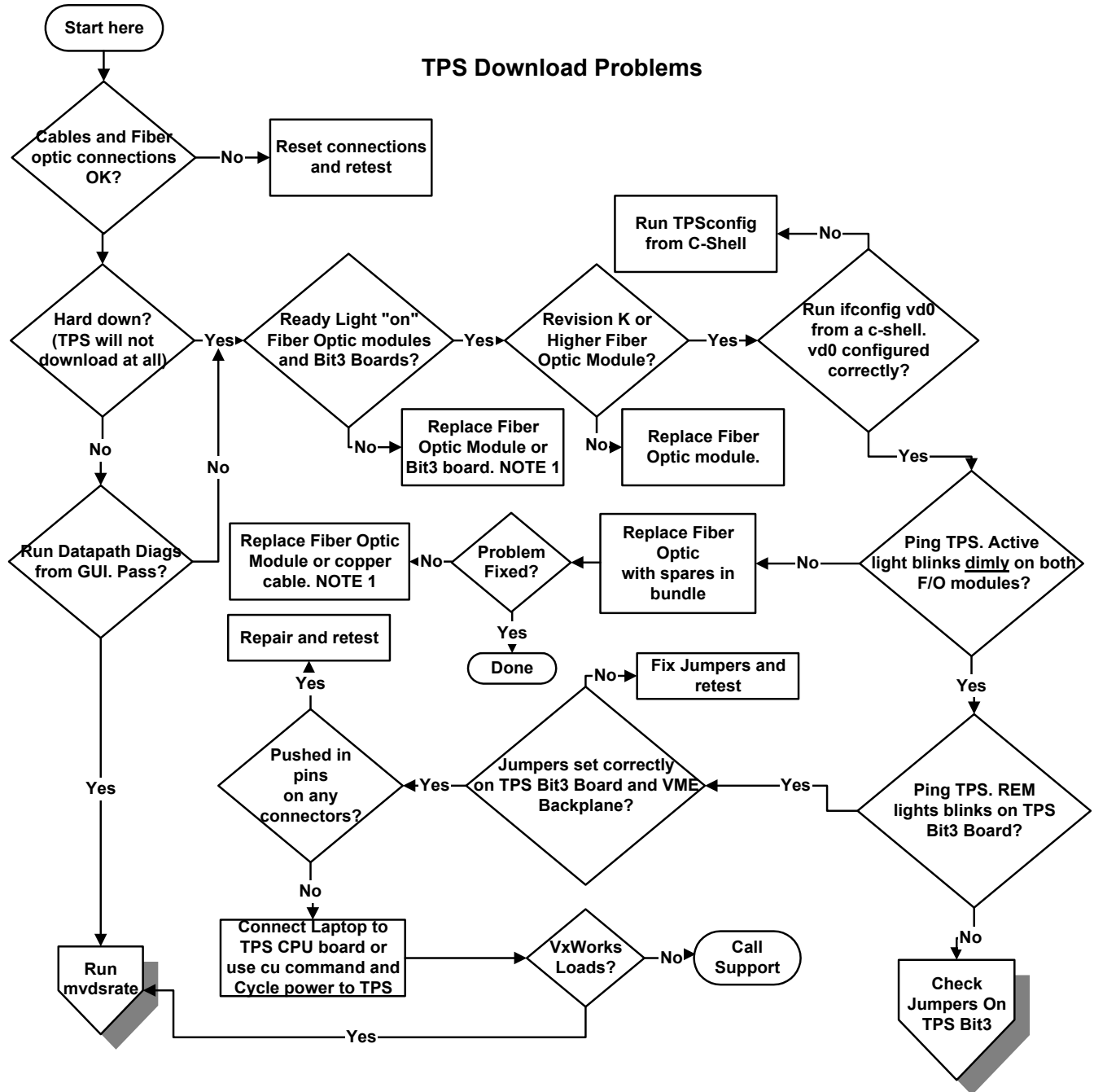

NOTE 1: Before Replacing Fiber Optic Module, adjust the 5 volt power supply inside the Fiber Optic Module to 5.2 volts.

NOTE 2: It is often necessary to cycle power on all the components in the Bit3 chain and reboot the computer during troubleshooting.

TPS Download Problems -Page 2

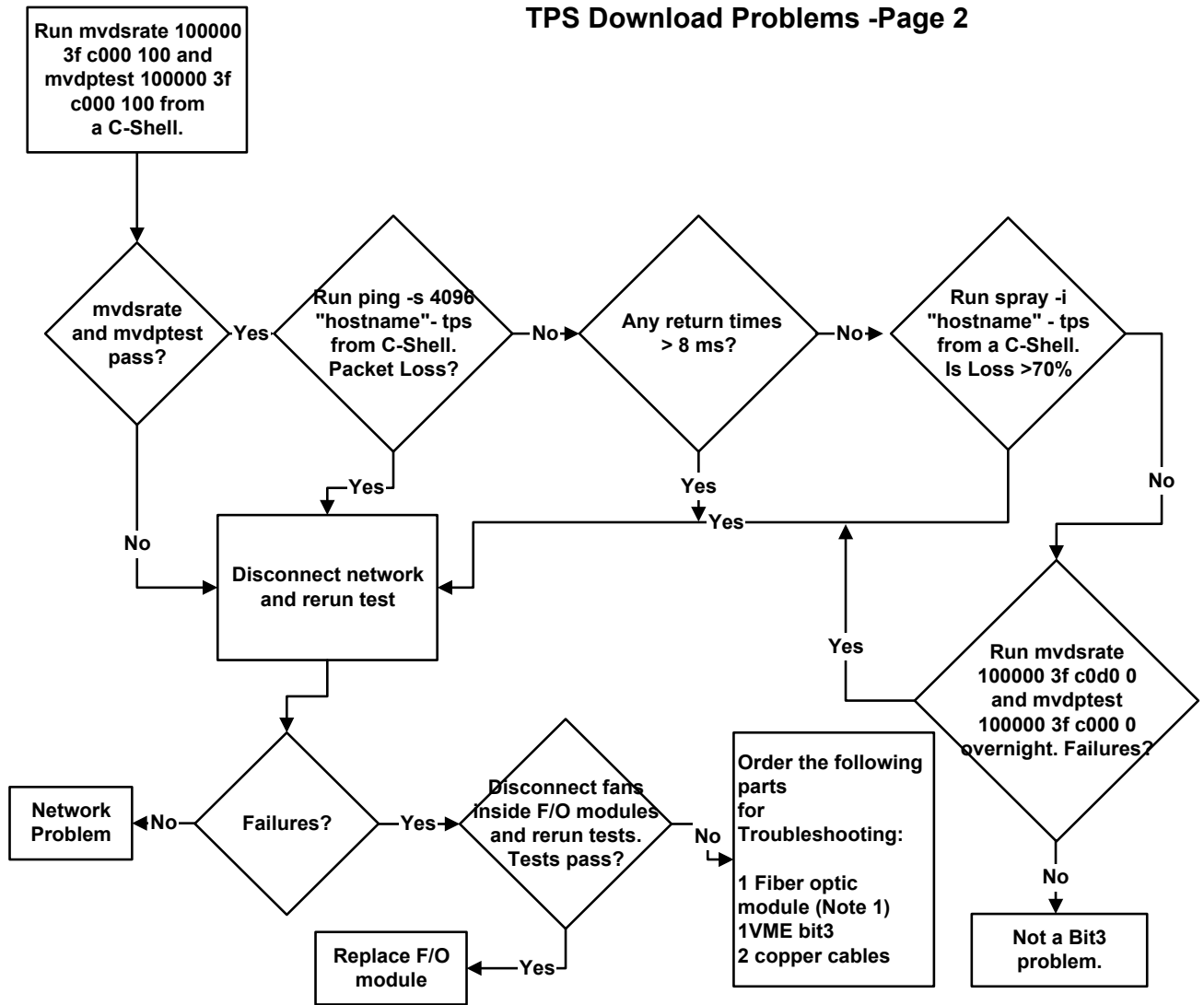

NOTE 1: Before Replacing Fiber Optic Module, adjust the 5 volt power supply inside the Fiber Optic Module to 5.2 volts.

NOTE 2: It is often necessary to cycle power on all the components in the Bit3 chain and reboot the computer during troubleshooting.

TPS Download Problems - Page 3

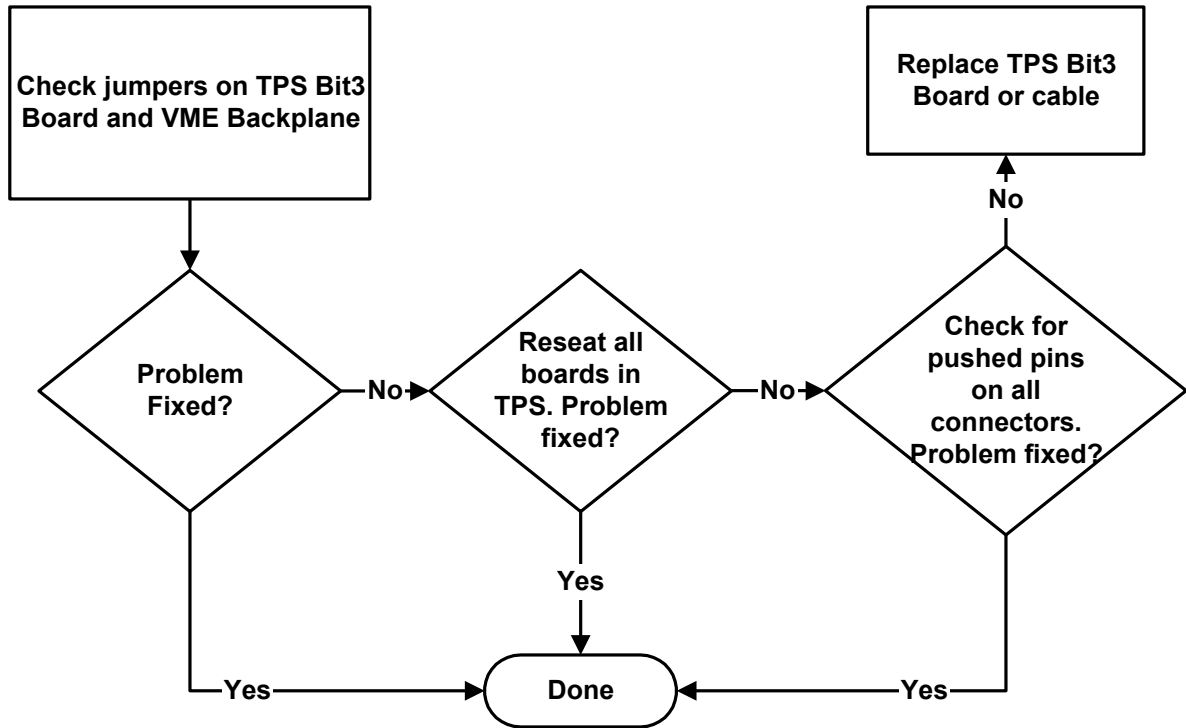

3- KNOWN BIT3 PROBLEMS

Problem: Incorrect jumper settings on VME Bit3 board in TPS.

Solution: Correct jumpers.

Problem: Cannot properly evaluate Bit3 troubleshooting tactics without power cycling entire system.

Solution: Recycle power on Bit3 components, and reboot whenever parts are replaced or swapped out.

Only Systems with Fiber Optic Modules:

Problem: The Fan induces electrical noise causing intermittent problems. Can be seen by using the large packet ping test.

Solution: Disconnect the fan and rerun test. Replace offending Fiber Optic Module.

Problem: Bad crimps on copper cable connected to Fiber Optic Module.

Solution: Replace cable.

Problem: Noisy Power Supply on Fiber Optic Module.

Solution: Replace Fiber Optic Module.

Problem: Pushed in pins on Bit3 cables/connectors.

Solution: Fix/replace cable or connector.

Problem: Low power supply voltage inside Fiber Optic Modules.

Solution: Adjust power supplies inside Fiber Optic Modules to 5.2 volts.

4- TROUBLESHOOTING TIPS (SYSTEMS WITH FIBER OPTIC MODULES)

4-1 Mouse Locks Up

If the mouse locks up on the SGI during system operation, and it does not function after a reboot of the SGI and the PC, be sure to read the message log. Watch the messages displayed on the System Monitor. If you see

“Bit 3 board type ... found. WARNING: cvdinitbd: Wrong remote 413 board type! (1)”

suspect a bad component in the Bit 3 communication link. These errors are also written to the /var/SYSLOG file.

One reason for this error is the constant interrupt state caused by bad hardware. Disconnecting the Bit3 cable or removing the Bit3 board would have allowed the SGI computer to operate normally (i.e. boot all the way to applications) and would have then indicated the problem occurred somewhere between the SGI and System Cabinet. If this does not work, try swapping the Bit 3 Fiber Optic cables. See Section 2-3 Duplicate Fiber Optic Cables.

4-2 TPS Reset Error Conditions

If you are getting errors regarding the TPS communication, it is possible that the Bit3 communication link is not functioning. Try a Reset TPS. If this does not work, it is possible that the Bit 3 communication link was not initialized. Bring the SGI down to the login screen, and re-boot. This will re-initialize the Bit 3 communication link.

If you are still have problems, bring the SGI down and power cycle SGI. If this does not work, try swapping the Bit 3 Fiber Optic links. See Section 2-3 Duplicate Fiber Optic Cables.

4-3 Duplicate Fiber Optic Cables



The Bit3 Fiber Optic Interface contains eight glass fiber cables, four in use and four extra. Use extreme caution when handling these cables. Damage to these cables may cause erroneous readings when the MRI unit is in use. There is a duplicate set of glass fiber optics in the protective sheathing for this cable run. These have been made available to aid in troubleshooting and isolating Bit 3 communication problems.

4-4 Bit-3 Communication Troubleshooting

Logout and re-login to Signa, or reboot the SGI. In either case, observe the IPG display. You should see it reset and perform power-up diags, and return to "IPG Boot". If it does not reset, check the Bit-3 link in the following order based on the likelihood of failure:

1. Check the fiber optic connections on the Bit3 F/O Modules. (Verify the each fiber line is installed in the correct connector and is fully seated.)
2. Check the Bit-3 Fiber Optic Modules in both the Systems Cabinet and the OW Cabinet.
 - a) The "RDY" LED should be ON for both Modules. If the "RDY" LED is off, verify the module has power. If it does, replace the bad Bit3 Fiber Optic Module. The "ACTIVE" LED should normally be OFF. If the "ACTIVE" LED is constantly ON or flashing when the system is idle (i.e. SGI is not trying to communicate with the TPS/ISE Chassis), this could be due to an improperly seated Bit3 fiber optic connector or a failed Bit3 Fiber Optic Module. Check all 8 Bit3 fiber optic connectors for proper seating; if OK, replace the bad Bit3 Fiber Optic Module.
 - b) Select **[TPS Reset]**. The "ACTIVE" LED in both Bit3 Fiber Optic Modules should blink dimly several times during the first 5 seconds after the TPS reset. (Additional blinks will follow during downloading if communication continues between the Host computer and the TPS/ISE Chassis.)
 - c) Reset both Bit3 Fiber Optic Modules.

- d) Systems shipped before March 10, 1997: Check the revision of the Bit3 Fiber Optic Module; it should be a Rev K (Rev K modules contain cooling fan for thermal fix and power-on lockup fix; Rev J modules contain only the cooling fan thermal fix). LX sites with earlier revision modules will be FMI'd to Rev K. If you suspect the Bit3 Fiberoptic Module, replace it. (Replacements are Rev K.)
- 3. Check the Bit-3 fiber optic cable. (Check each fiber with a flashlight. Replace any dim or broken fibers with one of the four spare fiber lines in the cable).
- 4. Reseat TPS/ISE Chassis Boards: IPG, CERD, Bit3, TPS CPU, AP
- 5. Check ISE Chassis voltages. (Measure digital and analog voltages on the TYME-II Board and adjust as needed.)
- 6. Check the Systems Cabinet Bit-3 Board; check/reseat the Bit3 cable.
- 7. Check the SGI Bit-3 Board; check/reseat the Bit3 cable.
- 8. If TPS download never worked: Check the Systems Cabinet Bit-3 jumper settings and the Systems Cabinet VME backplane jumper settings.

4-5 Simple Ping Test of The TPS

This test is to troubleshoot those elusive Bit3 communication problems which are intermittent in nature. Field experience has shown that if larger ping packets are used in a continuous test, the health of the communications link can be tested quickly, even if it appears to be only failing intermittently.

- 1) **Open a C-shell** from the Service desktop.

You must first determine the IP address of the TPS via the Bit3. This can be seen in the /etc/hosts file:

- 2) type: **more /etc/hosts <enter>**

You will get something that looks like this:

```
199.92.177.112  OPBOX_PC
199.92.177.113  FE_LAPTOP
199.92.177.100  lx-mr
216.33.27.1    lx-mr-tgate<----- This is the Bit3 board in the host
216.33.27.2    lx-mr-tps<----- This is the TPS. It always ends in ".2"
```

- 3) type : **ping -s 4096 aaa.bbb.ccc.ddd <enter>**{using your TPS address - not the tgate address}

You will get something that looks like this:

```
PING b3a-tps (216.33.27.2): 4096 data bytes
4104 bytes from 216.33.27.2: icmp_seq=0 ttl=255 time=5.668 ms
4104 bytes from 216.33.27.2: icmp_seq=1 ttl=255 time=6.275 ms
4104 bytes from 216.33.27.2: icmp_seq=2 ttl=255 time=6.188 ms
4104 bytes from 216.33.27.2: icmp_seq=3 ttl=255 time=5.958 ms
4104 bytes from 216.33.27.2: icmp_seq=4 ttl=255 time=6.283 ms
4104 bytes from 216.33.27.2: icmp_seq=5 ttl=255 time=5.950 ms
4104 bytes from 216.33.27.2: icmp_seq=6 ttl=255 time=6.046 ms
4104 bytes from 216.33.27.2: icmp_seq=7 ttl=255 time=6.024 ms
4104 bytes from 216.33.27.2: icmp_seq=8 ttl=255 time=6.085 ms
4104 bytes from 216.33.27.2: icmp_seq=9 ttl=255 time=6.103 ms
4104 bytes from 216.33.27.2: icmp_seq=10 ttl=255 time=6.104 ms
```

```
4104 bytes from 216.33.27.2: icmp_seq=11 ttl=255 time=6.047 ms
o
```

```
----b3a-tps PING Statistics----
12 packets transmitted, 12 packets received, 0.0% packet loss
round-trip min/avg/max = 5.668/6.061/6.283 ms
```

This output will continue to scroll as the ping test continues to loop. When you have seen enough type:

<Ctrl>C<enter> to terminate the test. Upon termination you will see a summary such as this:

```
-----216.33.27.2 PING Statistics-----
12 packets transmitted, 12 packets received, 0.0% packet loss
round-trip min/avg/max = 5.668/6.061/6.283 ms
```

Analysis:

With no other Bit3 traffic present (ie no scanning or reconstruction going on) the turnaround time should always be ~5-8 ms. Anything significantly longer is a problem. Anything shorter may indicate a problem as well such as a Bit3 mis-configuration (or you are actually pinging something other than the TPS).

The activity LED on the Bit3 Fiber Optic interface should blink dimly.

The summary should show “0% packet loss”. Anything else is a problem.

This test can be used before and after replacing one of the hardware modules in the Bit3 chain to determine if symptoms have changed. Field experience shows that even on those systems which only fail to communicate intermittently (PSD downloads fail, image reconstruction fails, etc.), the ping test has shown a steady problem state.

5- TROUBLESHOOTING BIT3 WITH ON-BOARD FIBER-OPTICS (RELEASE 8.3)

Beginning with release 8.3, the Fiber Optic Modules have been removed from the system. The new Bit3 boards have on-board fiber optics, therefore reducing the communication path to only three pieces (i.e. Computer Bit3, TPS Bit3, and Fiber). There is a spare set of fibers in the bundle for troubleshooting. Additionally, the new Bit3 boards have proprietary loopback diagnostics that will isolate one of the components in the Bit3 chain.

Note

The new Bit3 boards will only work on systems with an Octane computer because of the bus structure. Indigo computers use a GIO64 bus and Octane uses a PCI bus. The new board is only compatible with the PCI bus. No on-board fiber optic Bit3 board has been designed for Indigo. The fiber optic cables from the old system are not compatible with the new system.

5-1 Bit3 Diagnostics

The new Bit3 board has new proprietary diagnostics. The diagnostics are started from the diagnostic GUI shown in Illustration 5-1, provided a Service Key is installed. The new diags send data across the Bit3 link and verify that the data makes it back to the Host.

Note

The mentioned Diagnostics can only be run if the system is booted to Applications (**sdc**, password: **adw2.0**)

Keep in mind that these diags are quick because they are not data intensive. Each buffer sent is 256 bytes long. For each run of a BIT3 diag, the following occurs:

1. Send one buffer filled with the 0xAAAAAAAA data pattern over the BIT3 link.
2. Verify the buffer received back is also filled with 0xAAAAAAAA.
3. Send one buffer filled with the 0x55555555 data pattern over the BIT3 link.
4. Verify the buffer received back is also filled with 0x55555555.

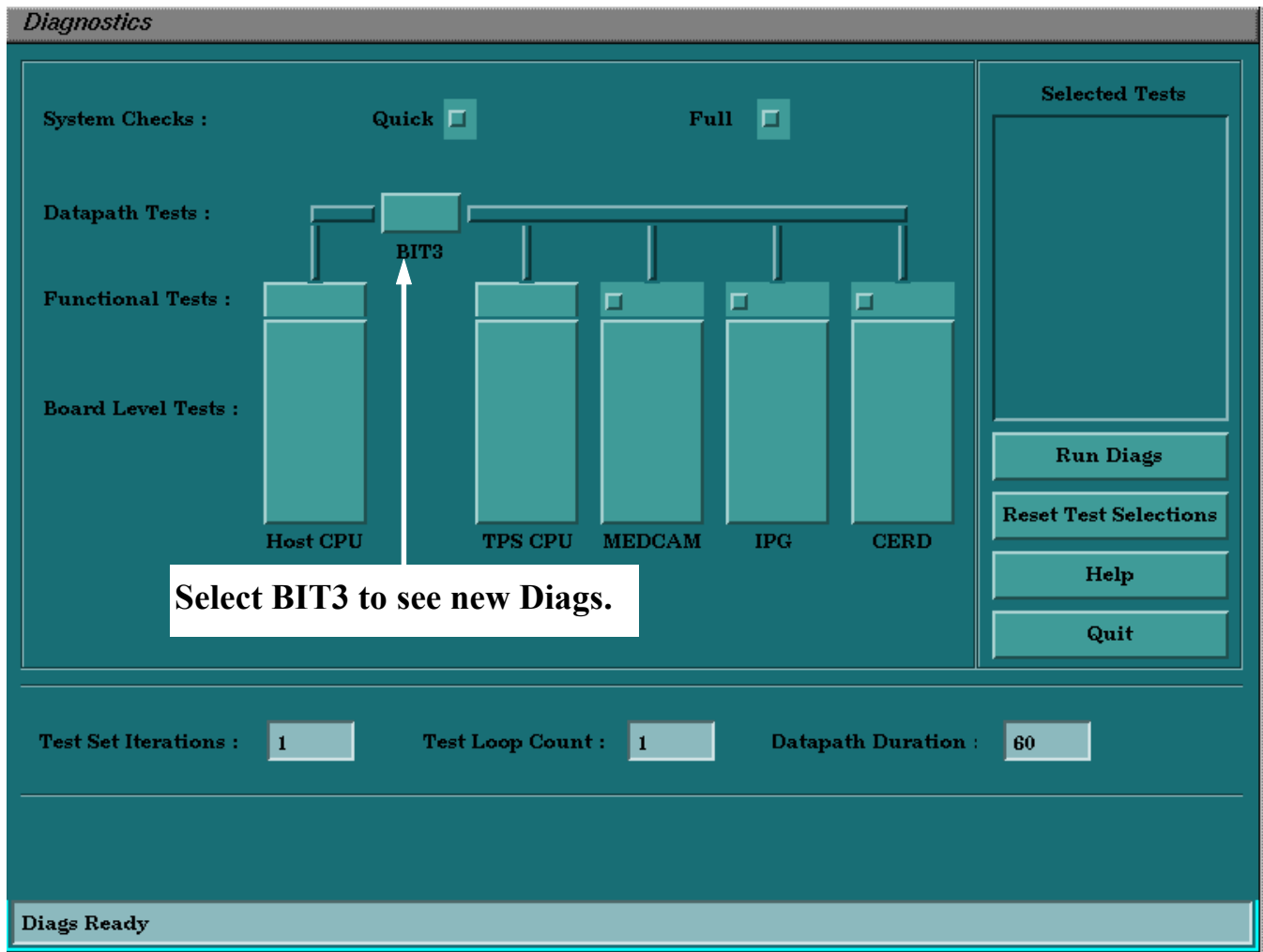

DIAGS SCREEN FOR NEW BIT3
ILLUSTRATION 5-1

Note

The new Bit3 Diag screen will only show up if it recognizes the system has the new Bit3 board in the Octane computer and a Service Key is installed.

The Bit3 Diags screen (Illustration 5-2) has three options to choose from.

- Full Host/TPS communication
- Host Board Only Test
- Advanced Bit3 Test

Note

Advanced Bit3 Test cannot be run with the other tests because it requires human intervention.

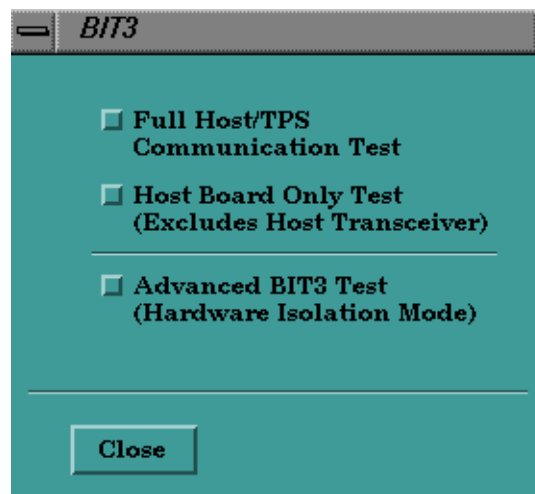

BIT3 DIAGS SCREEN
ILLUSTRATION 5-2

5-1-1 Full Host/TPS Communication Test

This diagnostic tests the entire Bit3 chain. Run this test first. If this test passes, increase the iterations and rerun the test. If it still passes, and you are experiencing TPS download problems revert to the traditional troubleshooting tests (i.e. ping, spray, etc.)

If the Full Host/TPS test fails, run the Host Board Only test, and the Advanced Bit3 tests to isolate the failing FRU.

5-1-2 Host Board Only Test

The Host Board Only test will run a loopback diagnostic on the Bit3 board in the Host computer. A failure of this diagnostic is most likely the Host Bit3 board in the computer. If this diagnostic passes, however, it does not mean that the Host bit3 board is OK. This test does not test the fiber optics on the Host Bit3 board, therefore the diags can pass even though the fiber optics on the Host Bit3 board are the problem.

5-1-3 Advanced Bit3 Test

The Advanced Bit3 Diagnostic requires the use of a fiber optic loopback connector. There are two loopback connectors provided with the system. The TPS loopback connector is built into the Bit3 board in the TPS chassis and is labeled "Loopback". The Host loopback connector is located on the fiber optic wire harness attached to the spare fiber optic cables on the host side of the Bit3 chain. See illustration 5-3 below for a picture of the loopback connector.

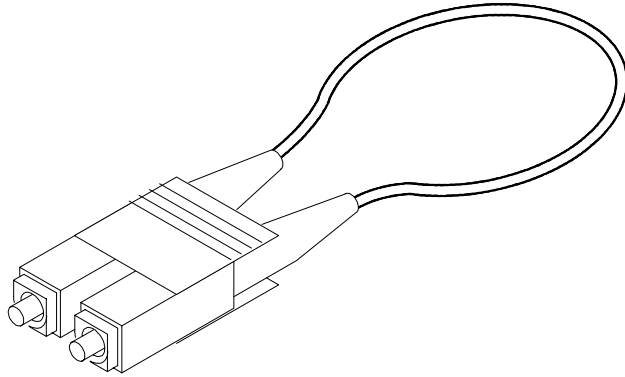

BIT3 LOOPBACK CONNECTOR
ILLUSTRATION 5-3



ADVANCED BIT3 TEST MUST BE SELECTED BEFORE INSTALLING THE LOOPBACK CONNECTOR OR THE SYSTEM WILL CRASH.

Note

The Advanced Bit3 Test should only be run if the “Full TPS/Host Communication Test” fails. The loopback connectors can be used in two different locations in the BIT3 chain. Follow these steps to isolate faulty Bit3 modules and identify the failing FRU.

1. First, simply move the loopback connector on the Host side from the spare wire harness and attach it directly to the Host BIT3 board. Run the BIT3 Advanced Diagnostic. If the diagnostic fails, the FRU is the Host BIT3 Board. 2235744-3. If the diagnostic passes, restore the original configuration and continue to step 2.
2. Move the fiber optic cable from the TPS BIT3 board to the connector above it labeled “Loopback”. Run the Advanced BIT3 Diagnostic. If the Diagnostic fails, the FRU is the fiber optic cable. Use the spare cables inside the fiber optic cable harness. If the Diagnostic passes, but the “Full Host/TPS Communication Test” fails, the FRU is the TPS BIT3 board. 2235744-2.

Note

These Instructions will pop up on the system when Advanced Bit3 Test is selected.

5-1-4 Bit3 Diagnostic from root level

1. Open a C-shell
2. Type the following command: **mvdsrate 100000 3f c000 100 <enter>**
3. Verify that no errors are returned, and that the transfer rate displayed is greater than 5000 kbytes/sec. A typical output is as follows:

```
Mvdsrate 100000 3f C000 100
.....pass 100
Transfer rate = 8269.617187 Kbytes/sec elapsed time = 1160867 usec

***** End of Test *****
```

4. If there are any error messages such as: **error during write cycle: 201** then there is a failure regardless of any transfer rate reported. If the system is connected to a site network, disconnect the site network from the network hub on the OW and test again. If the test now passes, then the problem is related to the external site network. If the test still fails, the problem is related to the Bit-3 hardware.

5-1-5 Bit3 Diagnostic Flowchart

Illustration 5-4 shows a troubleshooting flowchart for the new Bit3 diags.

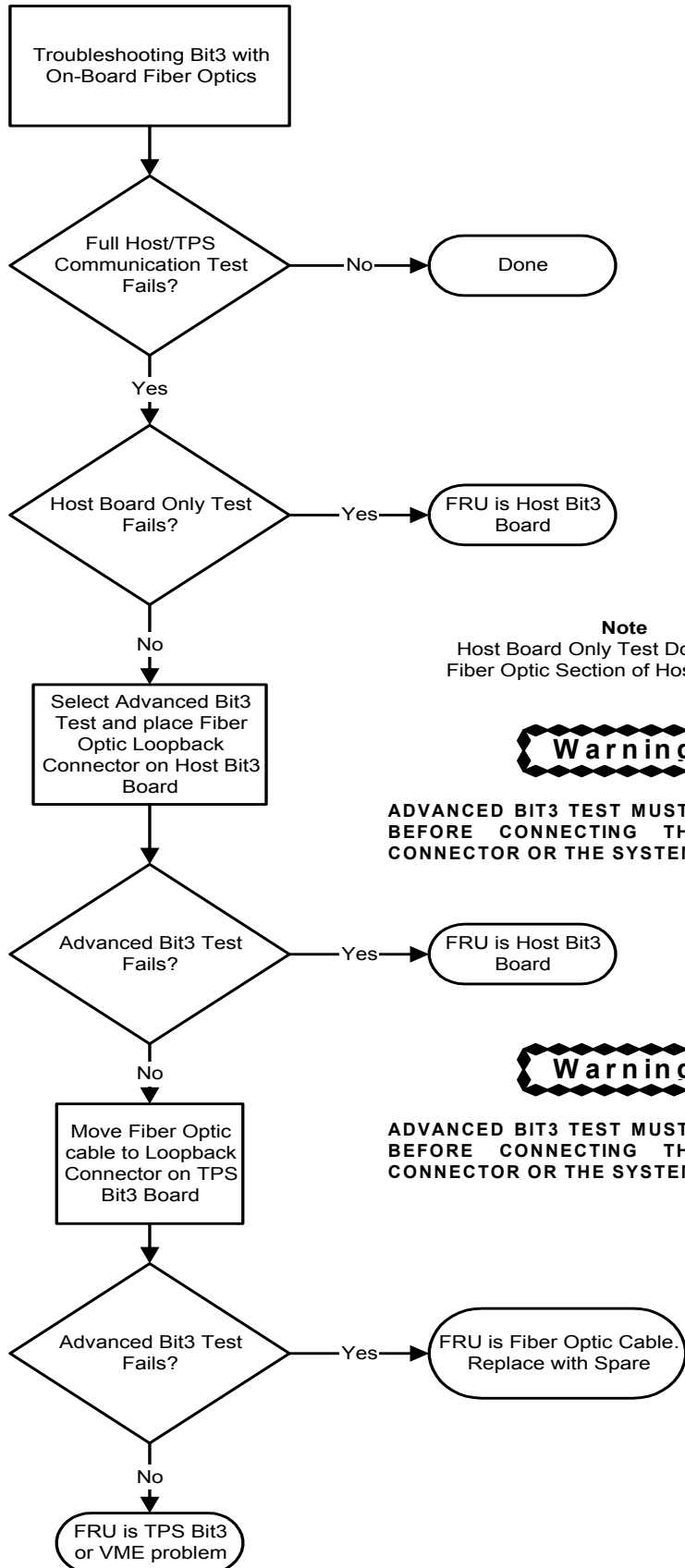

Note
Host Board Only Test Does not Test
Fiber Optic Section of Host Bit3 board.

Warning

ADVANCED BIT3 TEST MUST BE SELECTED BEFORE CONNECTING THE LOOPBACK CONNECTOR OR THE SYSTEM WILL CRASH.

Warning

ADVANCED BIT3 TEST MUST BE SELECTED BEFORE CONNECTING THE LOOPBACK CONNECTOR OR THE SYSTEM WILL CRASH.

**BIT DIAGNOSTICS TROUBLESHOOTING FLOWCHART (FIBER OPTIC BIT3 BOARDS)
ILLUSTRATION 5-4**

6- BIT3 VME BOARD JUMPER SETTINGS

A common problem with the TPS VME Bit3 board is the jumper settings. This is due to the fact that both CT and MR use the same VME Bit3 Board with different jumper settings, and often times the boards come directly from Bit3. Additionally, some Cardiac sites have a second Bit3 Board with different settings than the first Bit3 Board. See Illustration 6-1 for the first VME Bit3 Board, and Illustration 6-2 for the second Bit3 board jumper settings.

Note: MR VME Bit3 Jumpers are not the same as CT VME BIT3 Jumpers

DEFAULT CONFIGURATION

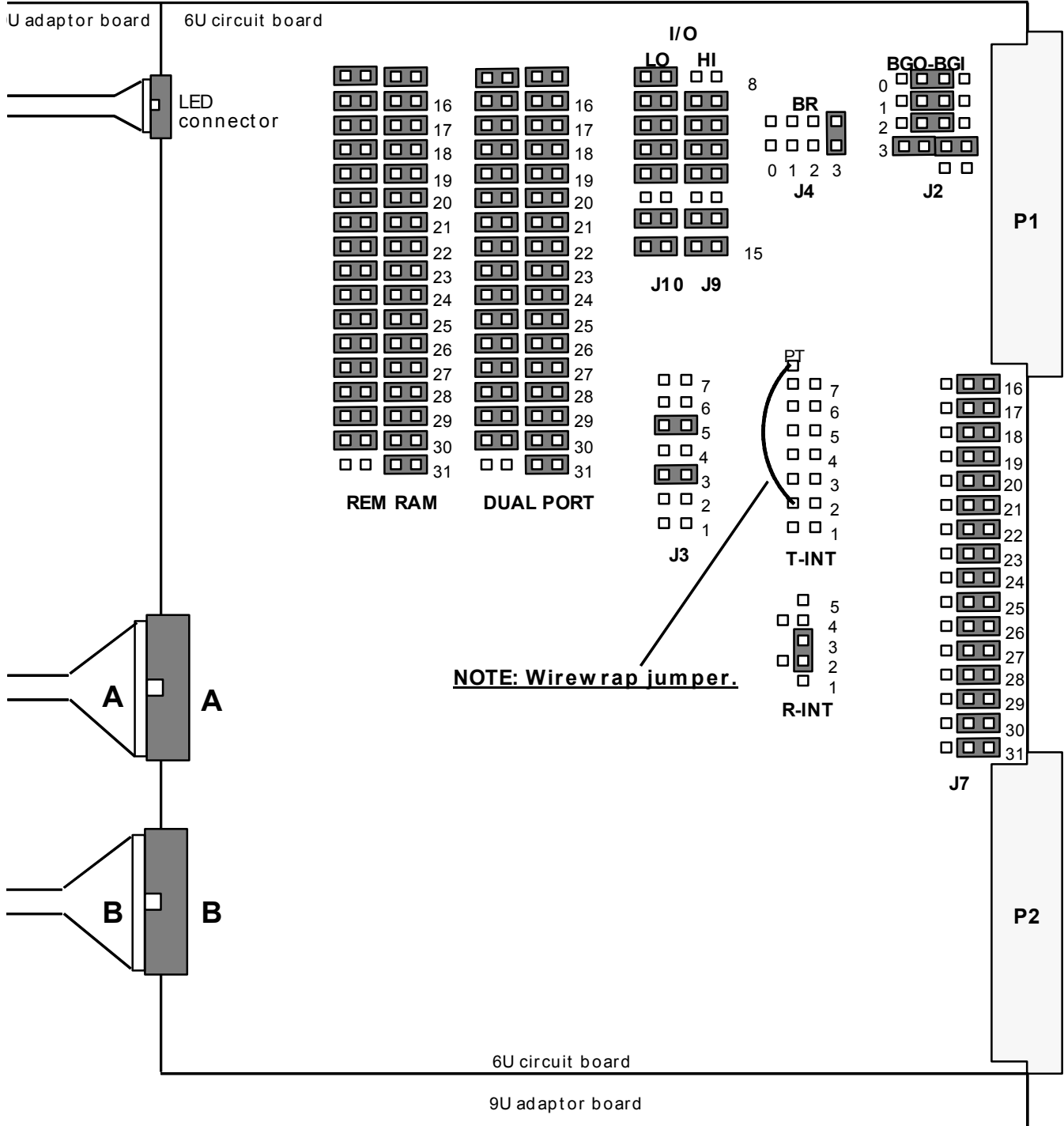

MR VME BIT3 BOARD JUMPERS
 ILLUSTRATION 6-1

Note: MR VME Bit3 Jumpers are not the same as CT VME BIT3 Jumpers

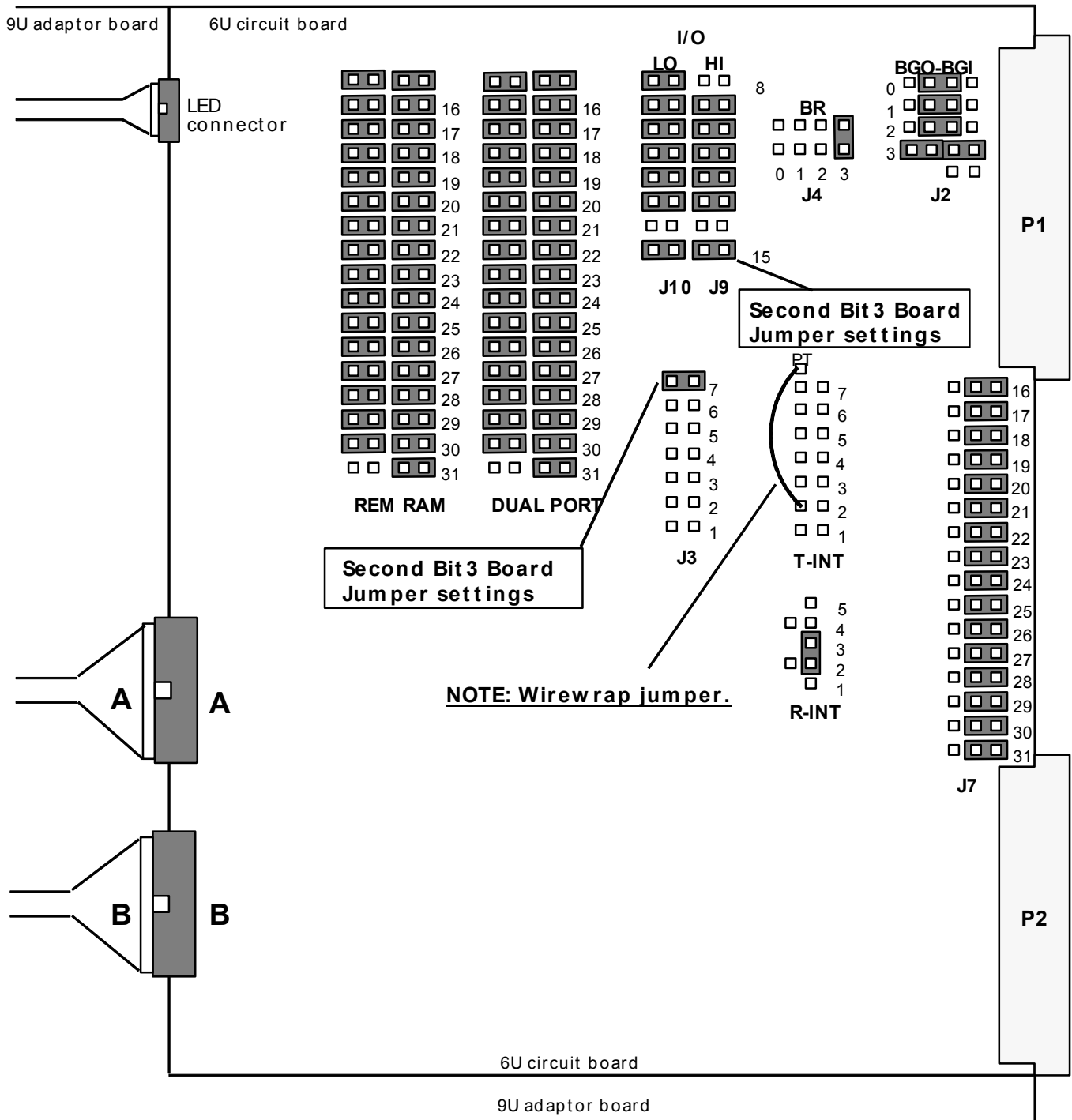

**MR SECOND BIT3 BOARD JUMPERS
 ILLUSTRATION 6-2**

APPENDIX A - EXCERPTS FROM SN60922

Symptom #1: SGI Appears to Lockup While Booting

If you see error messages on the display during SGI boot, go to Symptom #2 - *SGI Boot Errors*. If the SGI just appears to hang up, continue here:

Either disconnect one pair of the four Bit-3 fiber-optic cables, or turn off the Bit-3 box in the Systems Cabinet. Observe the SGI:

- If it now continues to boot, then there is a Bit-3 communication problem. Go to Troubleshooting: "*Bit-3 Communication Troubleshooting*".
- If it still is locked up, there is a problem with the SGI.

Symptom #4: "TPS Not Responding" Message

Observe the IPG display on the Systems Cabinet.

1. If it displays "IPG Boot" or "IPG RDY", then proceed to Troubleshooting: *Bit-3 Communication Troubleshooting*. **Note:** Knowing where the TPS download fails can provide important troubleshooting information. Connect a terminal to the TPS CPU Board in the Systems Cabinet (See Appendix A: *Using the Laptop as a Terminal* or *Using the LX-PC as a Terminal*.) Cycle power on the System Cabinet chassis and observe the messages. Refer to Appendix B - TPS CU Messages (For TPS Reset).
2. If the IPG display shows "PWRUP" or an errmes number, then it is failing some part of the power-up diagnostics. Connect a terminal to the TPS CPU board in the Systems Cabinet and observe the messages to determine the fault. (See Appendix A: *Using the Laptop as a Terminal* or *Using the LX-PC as a Terminal*.)
3. If the IPG appears to display an errmes number other than the normal power-up number, then note whether it occurs after you initiate a TPS reset or if it occurs during Power-up diags, before you get to the IPG Rdy message. If it occurs during power-up diags, then connect a terminal to the Systems Cabinet TPS CPU to determine the cause of the power-up diags failure in the Systems Cabinet. Otherwise, observe the Signa message log for messages that point to a problem with some part of the Systems Cabinet. (Note: See Appendix A: *Nuisance Message Log Messages* for messages you may be able to ignore.)

Symptom #5: TPS not responding with "IPG BOOT" After Host Software Load

Open a C Shell window on the SGI, and enter the following command:

```
ls /usr/g/service/log/gesys_iris.log <Enter>
```

If you get a response:

```
/usr/g/service/log/gesys_iris.log
```

This indicates that Signa was started at one time without performing the network configurations. This has been known to cause Systems Cabinet communications problems that continue even after network configuration. Perform Network configuration setup from the Install Menu.

TROUBLESHOOTING SECTION

#1 - Bit-3 Communication Troubleshooting

Logout and re-login to Signa, or reboot the SGI. In either case, observe the IPG display. You should see it reset and perform power-up diags and then return to "IPG Boot". If it does not reset, then check the Bit-3 link in the following order based on the likelihood of failure:

1. Check the fiber optic connections on the Bit3 F/O Modules. (Verify the each fiber line is install in the right connector and is fully seated.)
2. Check the Bit-3 Fiber Optic Modules in both the Systems Cabinet and the OW Cabinet.
 - a. The "RDY" LED should be ON for both Modules. If the "RDY" LED is off, verify the module has power. If it does, replace the bad Bit3 Fiber Optic Module. The "ACTIVE" LED should normally be OFF. If the "ACTIVE" LED is constantly ON or flashing when the system is idle (i.e. SGI is not trying to communicate with the TPS/ISE Chassis), this could be due to an improperly seated Bit3 fiber optic connector or a failed Bit3 Fiber Optic Module. Check all 8 Bit3 fiber optic connectors for proper seating; if OK, replace the bad Bit3 Fiber Optic Module.
 - b. Select **[TPS Reset]**. The "ACTIVE" LED in both Bit3 Fiber Optic Modules should dimly blink several times during the first 5 seconds after the TPS reset. (Additional blinks will follow during downloading if communication continues between the Host computer and the TPS/ISE Chassis.)
 - c. Reset both Bit3 Fiber Optic Modules.
 - d. Systems shipped before March 10, 1997: Check the revision of the Bit3 Fiber Optic Module; it should be a Rev K (Rev K modules contain cooling fan for thermal fix and power-on lockup fix; Rev J modules contain only the cooling fan thermal fix). LX sites with earlier revision modules will be FMI'd to Rev K. If you suspect the Bit3 Fiber optic Module, replace it. (Replacements are Rev K.)
3. Check the Bit-3 fiber optic cable. (Check each fiber with a flashlight. Replace any dim or broken fibers with one of the four spare fiber lines in the cable).
4. Reseat TPS/ISE Chassis Boards: IPG, CERD, Bit3, TPS CPU, AP
5. Check ISE Chasis voltages. (Measure digital and analog voltages on the TYME-II Board and adjust as needed.)
6. Check the Systems Cabinet Bit-3 Board; check/reseat the Bit3 cable.
7. Check the SGI Bit-3 Board; check/reseat the Bit3 cable.
8. If TPS download never worked: Check the Systems Cabinet Bit-3 jumper settings and the Systems Cabinet VME bus jumper settings.

#4 - Bit-3 Diagnostic Tests

As an aid in verifying the operation of the Bit-3 link, there are two diagnostics available from a shell window:

Transfer Rate Test

1. In a C Shell window on the SGI, enter the following command: **mvdsrate 100000 3f c000 100** <Enter>
2. Verify that no errors are returned, and that the transfer rate displayed is greater than 5000 kbytes/sec. A typical output is as follows:

```
mvdsrate 100000 3f c000 100
.....pass 100
Transfer rate = 8269.617187 Kbytes/sec  elapsed time = 1160876 usec

***** End of Test *****
```

3. If there are any error messages, such as: `error during write cycle: 201` then there is a failure regardless of any transfer rate reported. If the system is connected to a site network, disconnect the site network from the Network Hub in the OW Cabinet and run the test again. If the test now passes, then the problem is related to the external site network. If the test still fails however, then the problem is most likely hardware related (refer to #1 - Bit-3 Communication Troubleshooting).

Bit-3 Pattern Test

1. In a C Shell window on the SGI, enter the following command: **mvdptest 100000 3f c000 100** <Enter>
2. Verify that no errors are returned. A typical output is as follows:

```
mvdptest 100000 3f c000 100
attaching to MVD driver
initializing reference buffer pattern
writing reference buffer to target
beginning 256 read cycles

***** End of Test *****
```

3. If there are any errors, then an error will be reported as it occurs in the following format:

```
PASS 1:
pattern error at 00100000: 00010203 04050607 08090a0b 0c0d0e0f
      found =>           : 03030303 03030303 03030303 03030303
```

When invoking the *mvdptest* command, the last parameter (*100*) specifies the number of loops to run. If this test passes and you suspect something more intermittent, you can specify *0* (i.e. **mvdptest 100000 3f c000 0**). This will cause the test to loop forever, and you can then let it run overnight to see if any errors occur (press <Ctrl> <C> to stop the test). If the system is connected to a site network, disconnect the site network from the Network Hub in the OW Cabinet and run the test again. If the test now passes, then the problem is related to the external site network. If the test still fails however, then the problem is most likely hardware related (refer to #1 - Bit-3 Communication Troubleshooting).

Dowloading CAP file to CERD
 CERD oot successful
 cerd.i40 successfully loaded

<-- IPG DISPLAY = "DO SPU", "SPU LOAD"

Turning cerd_network internal packet logging ON
 CERD Network initialized...
 TPSSChas the SHRD_MEM_PTR !!!
 AD ofset for receiver 0 = 0
 AD offset for receiver 1 = 0
 AD offset for receiver 2 = 0
 AD offset for receiver 3 = 0
 Auto tart of Tardis done. CERD

<-- IPG DISPLAY = "12EF0100"

REVISION HISTORY

REV	DATE	AUTHOR	PRIMARY REASONS FOR CHANGE
0	06/16/98	R. Hawthorne	Initial conversation from ToolBook to Word
1	08/23/99	R. Hawthorne	Added Section 2-4 Bit-3 Communication Troubleshooting and section 2-5 Simple Ping Test Of The TPS.
2	09/28/99	R.Kaufman	Added section 3,4,5 and 6
3	10/01/99	R. Kaufman	Added section 3-1-4, Diag flowchart
4	Oct 13, 1999	M. Keber	Added correct proprietary heading to document; clarified which sections are for new or old Bit3 hardware.
5	Feb. 16, 2000	R. Kaufman	Changed order. Put T/S flowchart first
6	Mar 3, 2000	R. Kaufman	Added a way to start diags without apps running, and Appendix A, and B
7	Jan 27, 2005	P Kargard	Changes to Bit-3 troubleshooting