

## SECTION 8 – 3M LASER CAMERA

### TABLE OF CONTENTS

<u>SECTION</u>	<u>TITLE</u>	<u>PAGE</u>
8-1	CHECK LASER CAMERA FANS .....	8-2
8-2	CLEAN AND VACUUM LASER CAMERA INTERIOR.....	8-2
8-3	CLEAN LASER CAMERA SUCTION CUPS .....	8-3
8-4	CLEAN LASER CAMERA TRANSPORT PLATE/DOCKING UNIT .....	8-3
8-5	RUN LASER CAMERA CLEANING FILM.....	8-4
8-6	CLEAN LASER CAMERA EXTERIOR .....	8-6
8-7	CHECK LASER CAMERA AIR SHOCK PRESSURE (MOBILES ONLY).....	8-6
8-8	REPLACE LASER CAMERA EXTERNAL DOCKING UNIT SWITCHES .....	8-7

**Note**

**For KODAK Cameras:** the field should direct the customer to KODAK 1-800-544-7009 ONCE they are clear that the customer does not have an existing service agreement that has not expired yet for camera coverage.

**Note**

Section 8-1, and Sections 8-3 through 8-5 should be performed during the same PM visit. Alcohol pads, lint-free cloth and cleaning film used in this section are from 3M Cleaning Kit (46-266975P57).

**8-1 CHECK LASER CAMERA FANS**

Verify operation of three fans at rear of camera and clean MMU grill, if applicable.

**8-2 CLEAN AND VACUUM LASER CAMERA INTERIOR**

1. Lift Optics Module. Latch release is on right side of module. See Illustration 8-1.

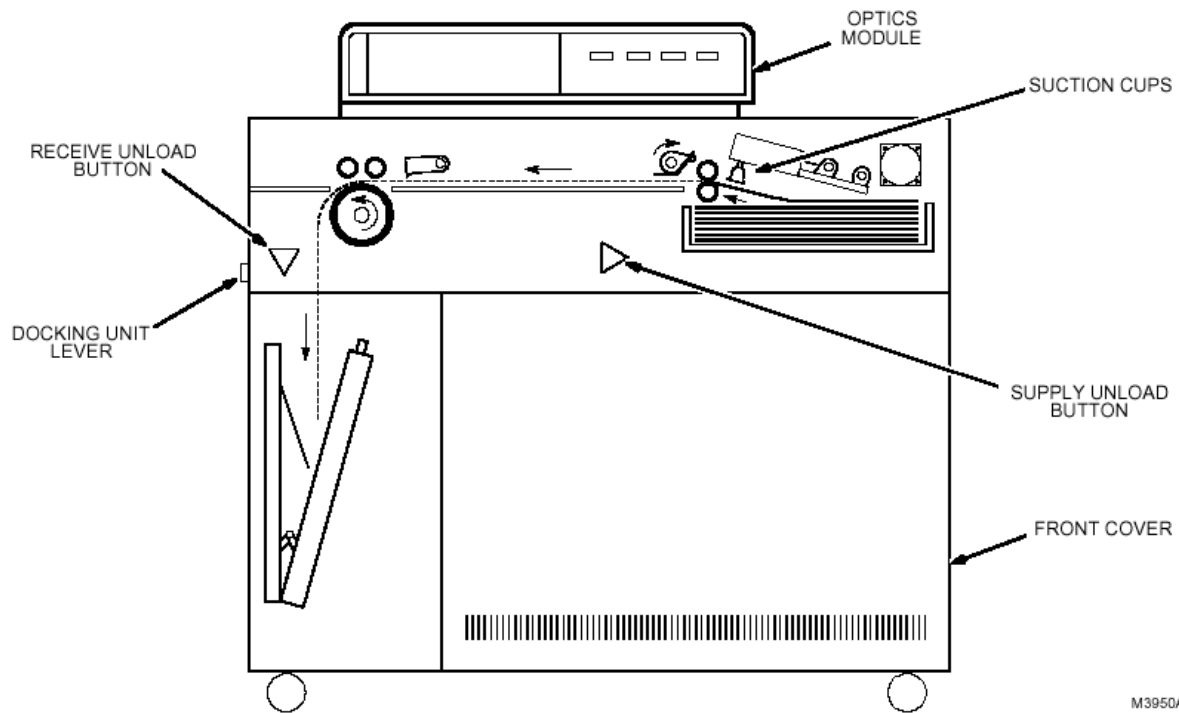

**CLEAN LASER CAMERA INTERIOR AND SUCTION CUPS**

ILLUSTRATION 8-1

M3950A

2. Place docking unit lever in MAGAZINE position.
3. Press Receive Unload and Supply Unload buttons and open both magazine drawers.
4. Remove two screws on each side of front cover. Slide front cover to right and remove it.
5. Vacuum interior of laser camera and the filter on bottom of front cover.
6. Replace front cover and close magazine.

**8-3 CLEAN LASER CAMERA SUCTION CUPS**



**Avoid damaging suction cups. Never use alcohol. Alcohol destroys rubber, resulting in premature failure of cups.**

1. Inspect the suction cups for uneven wear. Cups will be elliptical if unevenly worn. If any of the cups show uneven wear, replace all four.
2. Dampen a soft, lint-free cloth with water. Wipe underside of each suction cup. See Illustration 8-1.
3. Dry each cup thoroughly. No moisture should remain on cup.

**8-4 CLEAN LASER CAMERA TRANSPORT PLATE/DOCKING UNIT**

1. Clean Transport Plate with alcohol pads. Allow plate to air dry.
2. If camera is docked to a non-3M processor (such as a Kodak), do Step 3. If no Docking Unit, go to Step 4.
3. Clean Docking Unit.
  - a. Open Docking Unit top cover using two knobs located on either side. See Illustration 8-2.
  - b. Clean stainless steel Docking Unit Plate using alcohol pads. Allow Plate to air dry.
  - c. Check the rubber rollers for emulsion buildup. Clean with a water-dampened rag if needed.
4. Close Docking Unit top cover.
5. Close Optics Module.

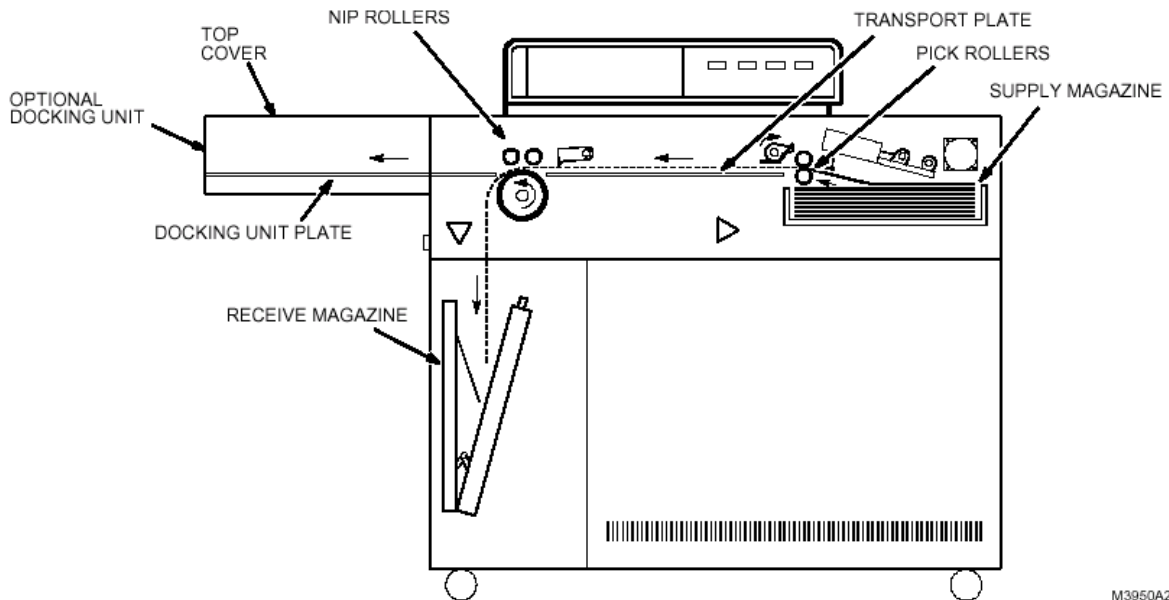

**CLEAN LASER CAMERA PLATES AND ROLLERS**  
 ILLUSTRATION 8-2

**8-5 RUN LASER CAMERA CLEANING FILM**

**Note**

It may be necessary to run a cleaning film (from 3M Cleaning Kit) through camera as often as once a week to keep rollers clean. See Illustration 8-2. If laser camera is generating intermittent 22 errors, pick rollers may have emulsion build-up. Once emulsion has built up, you may have to clean pick rollers with water. Do not use alcohol.

1. Make sure camera power is ON and camera is Ready (i.e. No Alarms)

**Note**

A valid user must be selected on local panel. This user must have acquired an image since camera power up. Otherwise the Density Test will not work.



**The supply magazine may have film in it. Take magazine to darkroom before opening. Only a green safelight should be used when magazine is open. Do not use a red safelight since it will expose unused film.**

2. Press Supply Load button to open supply magazine drawer and access supply magazine. See Illustration 8-3.

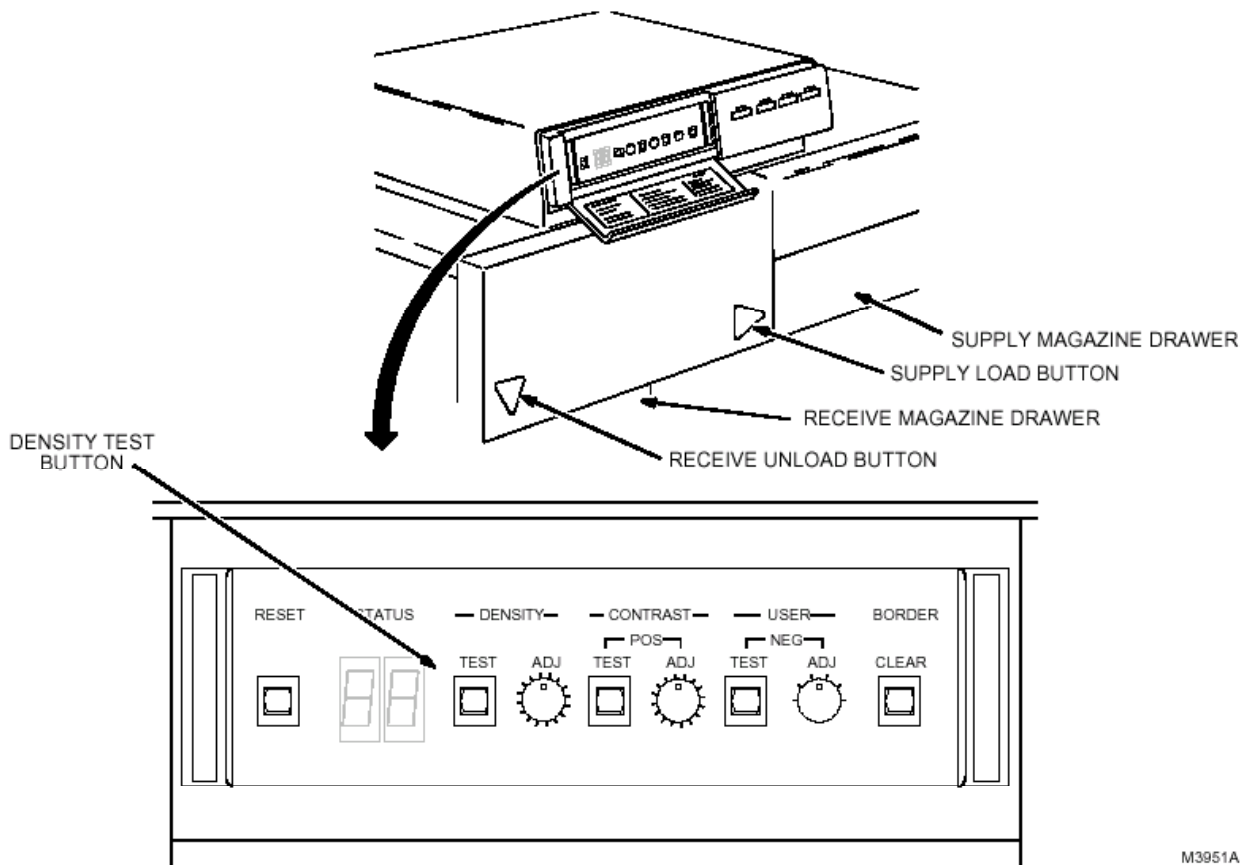

LASER CAMERA CONTROLS  
 ILLUSTRATION 8-3

M3951A

**8-5 RUN LASER CAMERA CLEANING FILM (continued)**

3. Peel protective paper from cleaning film. Place film on top of any existing film in supply magazine, adhesive side up.
4. Close magazine in darkroom and place in supply magazine drawer.
5. Press DENSITY TEST button on local panel. See Illustration 8-3.

**Note**

A valid user must be selected on local panel. This user must have acquired a image since camera power up. Otherwise the Density Test will not work.

6. When "Ready" light is ON, cleaning film is in receive magazine.



**If camera is not docked to a processor, receive magazine may have film in it. Take magazine to darkroom before opening. Only a green safelight should be used when magazine is open. Do not use a red safelight since it will expose unused film.**

7. Press Receive Unload button to open receive magazine drawer and access receive magazine.
8. Remove receive magazine from drawer and open magazine in dark room.
9. Remove cleaning film from magazine and check to see if adhesive side of film is still tacky. If it is **not** tacky, repeat Steps 2 through 9 with a new cleaning film until it comes out tacky.
10. If camera is docked to a processor, put docking unit lever back into PROCESSOR position.

**8-6 CLEAN LASER CAMERA EXTERIOR**

Use alcohol pads and soft, lint-free cloth to clean any dirt on exterior panels.

**8-7 CHECK LASER CAMERA AIR SHOCK PRESSURE (MOBILES ONLY)**

Check the air pressure on the gauge on the lock-down plate at the back right-hand corner of the imager. It should read 55 to 60 psi. If the pressure is not correct:

1. Remove the valve cover on the T-connector at the front of the right lock-down plate. (See Illustration 8-4.)
2. Attach an air pump to the valve stem on the T-connector.
3. Add enough air to bring the reading on the gauge to between 55 to 60 psi.

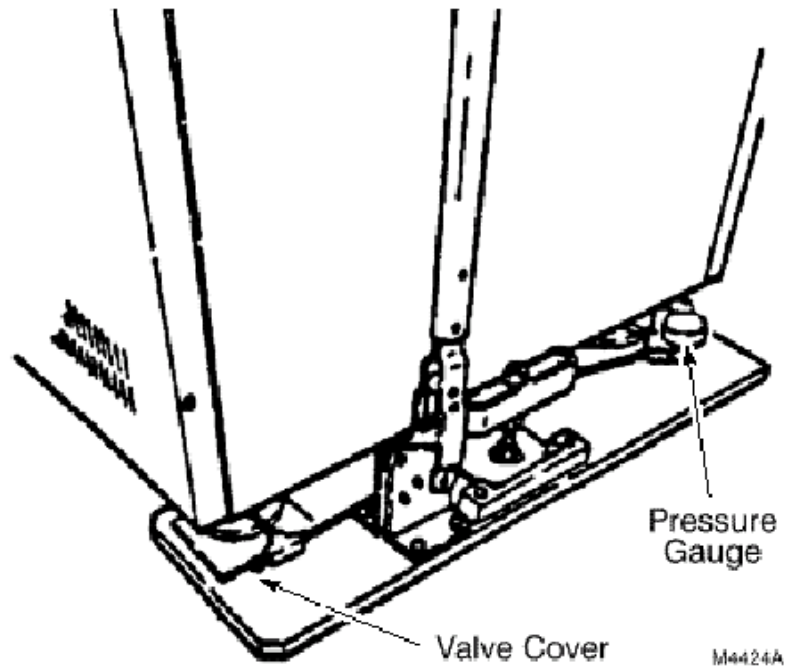

ADJUSTING LASER CAMERA AIR SHOCK PRESSURE  
 ILLUSTRATION 8-4

**8-8 REPLACE LASER CAMERA EXTERNAL DOCKING UNIT SWITCHES**

There are 4 switches in the external docking unit that fail often enough to justify replacing them on a scheduled basis. If the customer lifts the cover of the docking unit every evening (this vents processor vapor), the switches should last several years. However, history has shown that many customers forget to do this task.

1. Remove S1, S2, S3, and S4. There are 2 screw and 2 push on spade connectors per switch. See Illustration 8-5.
2. Install new switches: S1, S2 (MMM 78-8053-4495-5, GE 46-266975P69), S3 (MMM 78-8053-4493-0, GE 46-266975P119), and S4 (MMM 78-8053-4496-3, GE 46-266975P120).
3. Adjust both switch positions so that there is minimal clearance between the switch actuator and the switch body. This will insure that the film will actuate the switch. See Illustration 8-5.
4. Verify operation by printing a film.

