

SECTION 5 – POWER DISTRIBUTION UNIT

TABLE OF CONTENTS

<u>SECTION</u>	<u>TITLE</u>	<u>PAGE</u>
5-1	CHECK STANDARD PDU FANS AND FILTERS	5-2
5-2	CHECK STANDARD PDU EMERGENCY OFF AND STOP CIRCUITS/INDICATOR LIGHTS.....	5-3
5-3	INSPECT STANDARD PDU AND POWER CONNECTIONS	5-5
5-4	CHECK POWERTECH AND/OR TRANSTECTOR	5-7
	5-4-1 Transtector	5-7
	5-4-2 Powertech Regulator.....	5-7
	5-4-3 Check Powertech Suppressor/Filter.....	5-11
	5-4-4 Check Powertech Regulator Voltages and Blower	5-11
5-5	CHECK COMPACT PDU FANS AND FILTERS	5-12
5-6	CHECK COMPACT PDU EMERGENCY OFF AND STOP CIRCUITS/INDICATOR LIGHTS.....	5-15
5-7	INSPECT COMPACT PDU AND POWER CONNECTIONS	5-17
5-8	CHECK TEAL PDU MODULE IN RF/PDU CABINET EMERGENCY OFF AND STOP	5-18
5-9	INSPECT TEAL PDU POWER CONNECTIONS	5-20
5-10	CHECK PDU MODULE IN ACGD CABINET EMERGENCY OFF AND STOP	5-21
5-11	INSPECT THE ACGD CABINET PDU POWER CONNECTIONS.....	5-23

5-1 CHECK STANDARD PDU FANS AND FILTERS

Note

There are two versions of the standard PDU. One has a regulator in the lower part with an opening in the bottom panel to access the regulator controls. The other has a transformer in the lower part. This PDU with the transformer has a grill on the bottom panel that covers the fans and filters. There are three different mounting methods for the grill. Illustration 5-1 shows these differences.

1. Remove grill and filters from bottom of PDU. See Illustration 5-1.

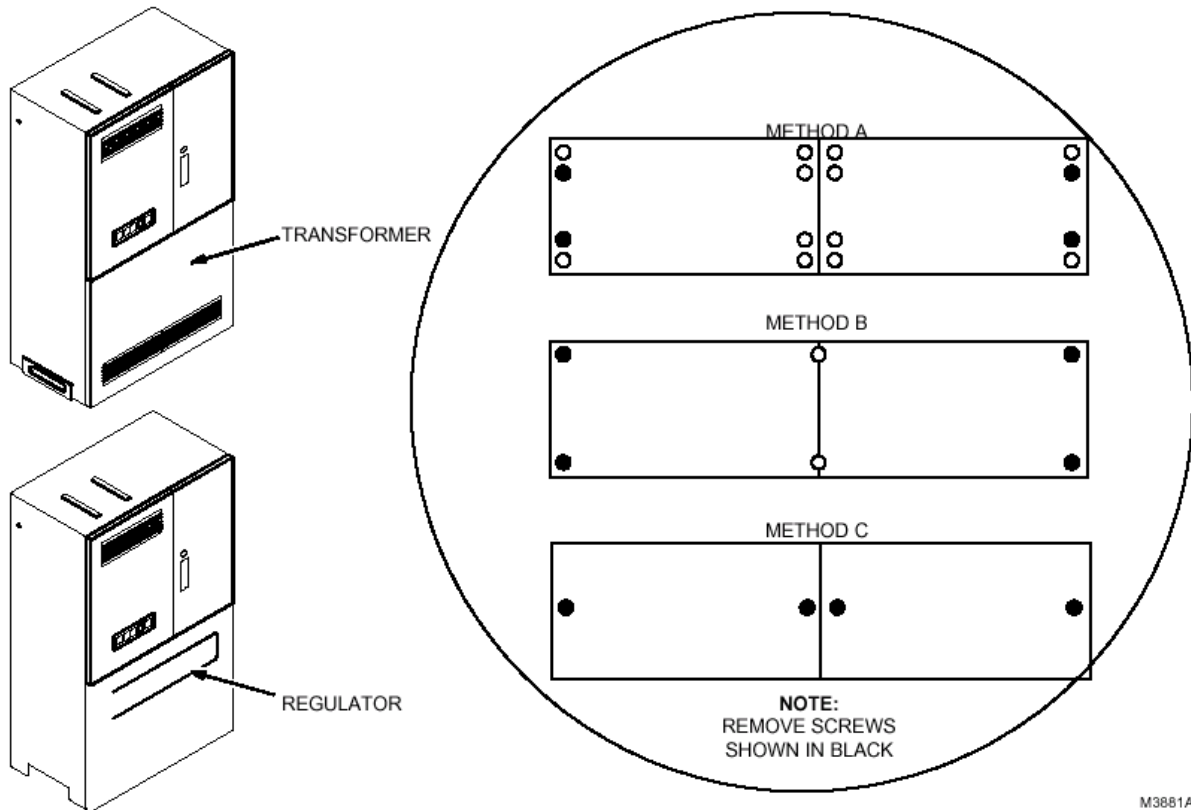

PDU GRILL STYLES
 ILLUSTRATION 5-1

M3881A1

2. Using a ty-wrap, probe three fans inside and below filters to check that fans are operating. Replace fans(46-208986P1), if necessary.
3. Inspect filters and replace (46-221883P1), if necessary. Re-install grill and filter on PDU.
4. Using a ty-wrap, probe three fans behind grill in top left front of PDU to check that fans are operating. Replace fans (46-208986P1), if necessary.

5-2 CHECK STANDARD PDU EMERGENCY OFF AND STOP CIRCUITS/INDICATOR LIGHTS

Note

Because this procedure requires the PDU to be shut off, the following procedures should be performed at the same time:

- Perform PAC-II Leakage Current Test, Section 1-3
- Inspect Standard PDU and Power Connections, Section 5-3

1. Perform System Shutdown. **Refer to Appendix B.**
2. Press one of the following EMERGENCY STOP buttons:
 - Operator Console
 - PDU Remote Control on System Cabinet
 - Magnet Enclosure front cover (two buttons - left and right).
3. Verify that contactors K6 through K12 all de-energize. See Illustration 5-2.
4. Press Full ON button at PDU.

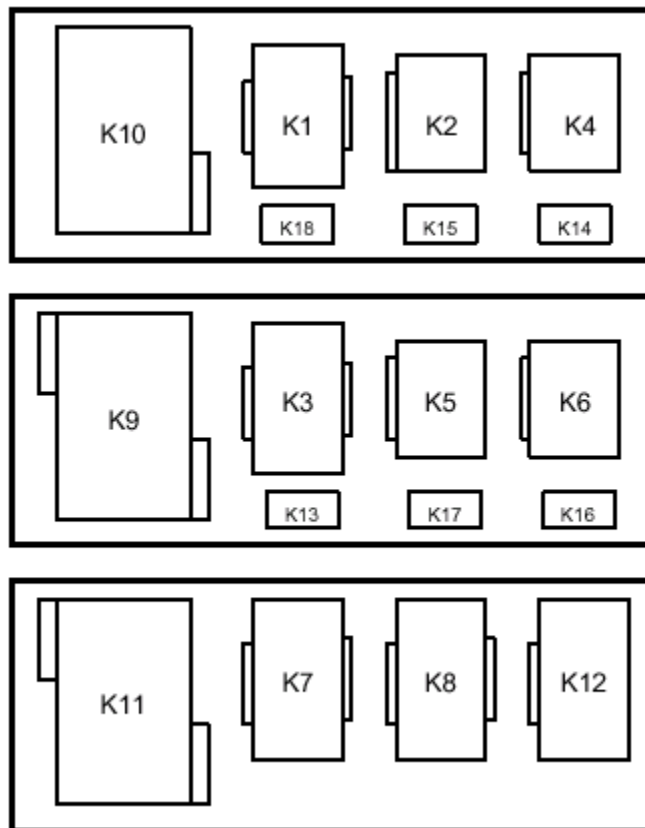

CONTACTORS
 ILLUSTRATION 5-2

5-2 CHECK STANDARD PDU EMERGENCY OFF AND STOP CIRCUITS/INDICATOR LIGHTS (continued)

5. Repeat Steps 2 through 4 for each of the other three EMERGENCY STOP buttons.

Note

If system is equipped with a Transtector, alarm on Transtector may sound when EMERGENCY OFF button is pressed. Push RESET button on Transtector to turn OFF alarm.

6. Press one of the following EMERGENCY OFF buttons:
 - Near computer equipment room door
 - Near magnet room door
 - On main power disconnect.
7. Verify red light on Main Power Disconnect goes OFF.
8. Reset main power disconnect at PDU by turning it OFF, then back ON.
9. Repeat Steps 6 through 8 for other EMERGENCY OFF buttons.



Potential shock hazard. Signa must be shutdown and cabinets powered OFF before replacing any PDU indicator bulbs.

Note

Remote PDU panel bulbs may be changed without powering down Signa. When right door of PDU is opened, an interlock switch disables remote panel buttons.

10. Verify that all bulbs used to backlight PDU buttons and PDU remote panel buttons are operational. Replace bulbs (46-170045P11), if necessary.

5-3 INSPECT STANDARD PDU AND POWER CONNECTIONS

1. Turn OFF main power disconnect.



BE SURE INPUT POWER TO THE PDU IS PROPERLY LOCKED AND TAGGED OUT!! YOUR LIFE COULD DEPEND ON IT!!



SHOCK HAZARD! USE A DIGITAL VOLT METER (DVM) TO VERIFY POWER IS OFF BEFORE WORKING INSIDE PDU.

2. Remove two screws securing cover over secondary power circuit breakers and remove cover. See Illustration 5-3.

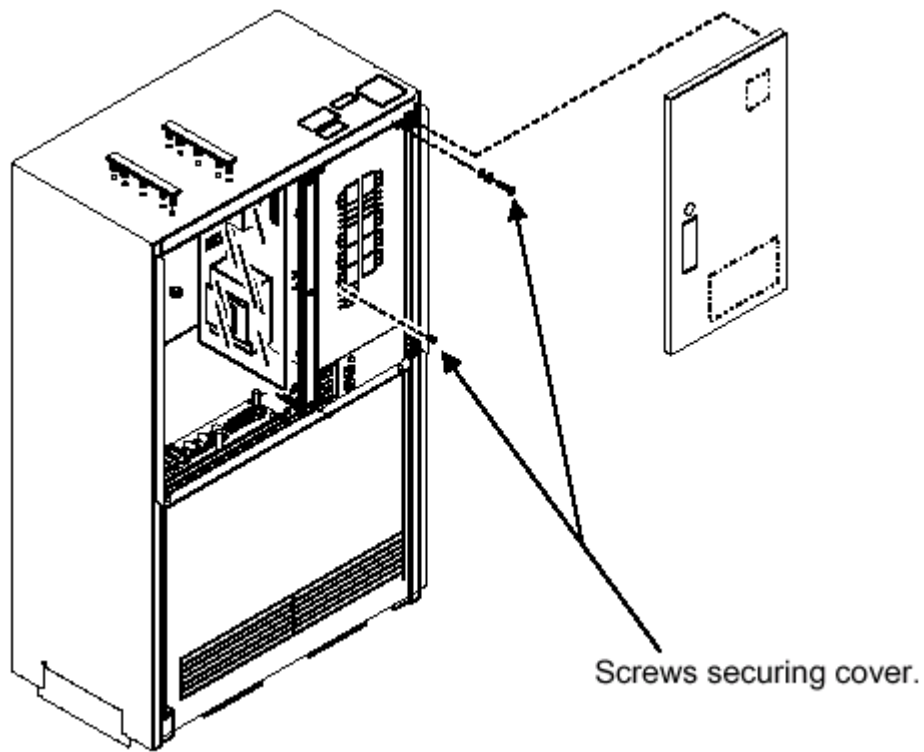

REMOVING COVER TO SECONDARY BREAKERS
ILLUSTRATION 5-3

3. Check and tighten all connections to these circuit breakers, then reinstall cover.

5-3 INSPECT STANDARD PDU AND POWER CONNECTIONS (continued)

4. Open left door of PDU by removing three screws securing door.
5. Check and tighten connections to contactors K1 through K12. See Illustration 5-2.
6. Remove plastic cover from over terminal strip (TS1) and two bus bars (ground and neutral) located on left side of PDU.
7. Check and tighten all connections to TS1 and both bus bars, then reinstall plastic cover.
8. Clean inside PDU. Vacuum any dust accumulation.
9. Inspect circuit boards for evidence of overheating, physical damage, and corroded connections. Replace any board that is damaged.
10. Check connectors on circuit boards for proper seating.
11. Turn ON main power disconnect.

Note

Before performing System Startup (refer to note at beginning of Section 5-2), make sure all other procedures requiring PDU to be shut OFF have been performed.

12. Perform System Startup (refer to Appendix B).

5-4 CHECK POWERTECH AND/OR TRANSTECTOR

5-4-1 Transtector

Verify green lights for all three phases are ON, if not check the bulbs. If it is not the bulbs, troubleshoot the Transtector. Call Support if needed.

Note

If there is not a Powertech at this site, you are done with this section.

5-4-2 Powertech Regulator

Checking EPO and RESET Indicators

1. Verify that EPO (Emergency Power OFF) and RESET indicators are ON. See Illustration 5-4 for location of indicators on a standalone Powertech and Standard PDU. See Illustration 5-5 for location of indicators on a Compact PDU.
2. Perform System Shutdown. **Refer to Appendix B.**



SHOCK HAZARD! USE A DIGITAL VOLT METER (DVM) TO VERIFY POWER IS OFF BEFORE WORKING INSIDE POWERTECH REGULATOR.

3. Replace indicator bulbs (46-307819P18) as required.

5-4-2 Powertech Regulator (continued)

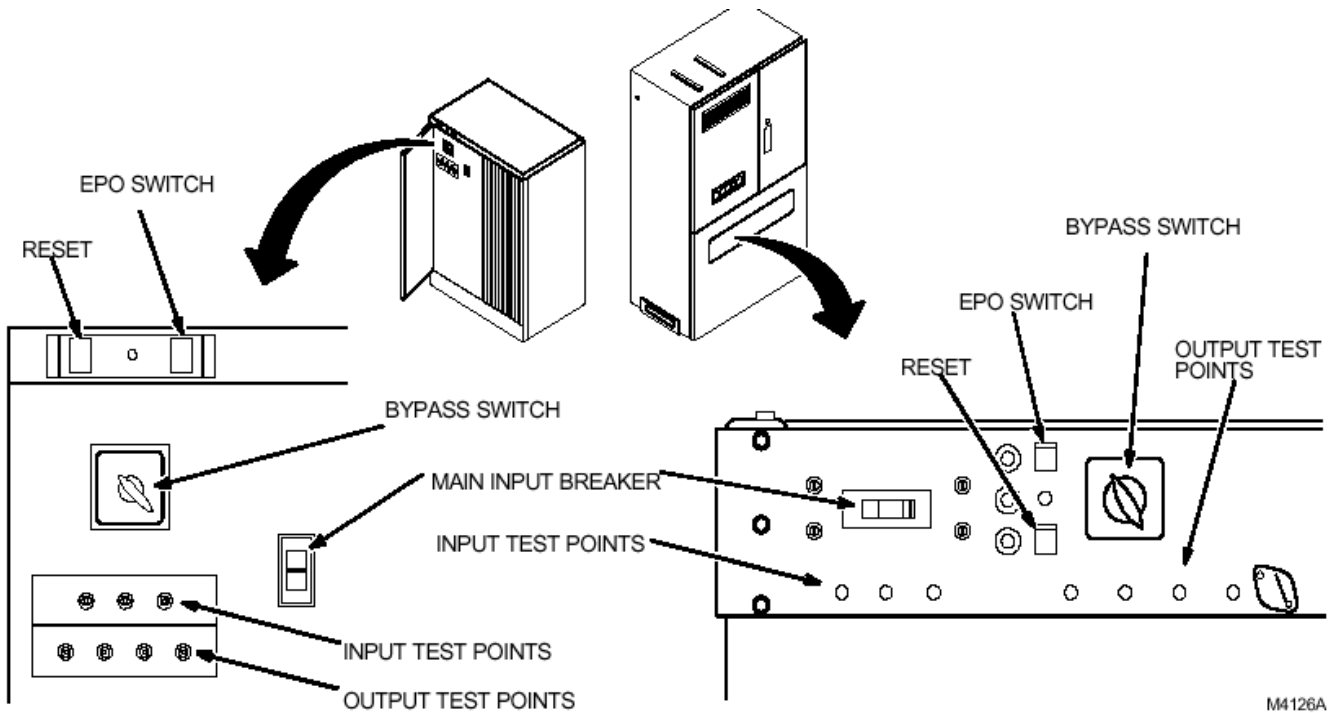

REGULATOR SWITCH AND TEST POINT LOCATION
ILLUSTRATION 5-4

5-4-2 Powertech Regulator (continued)

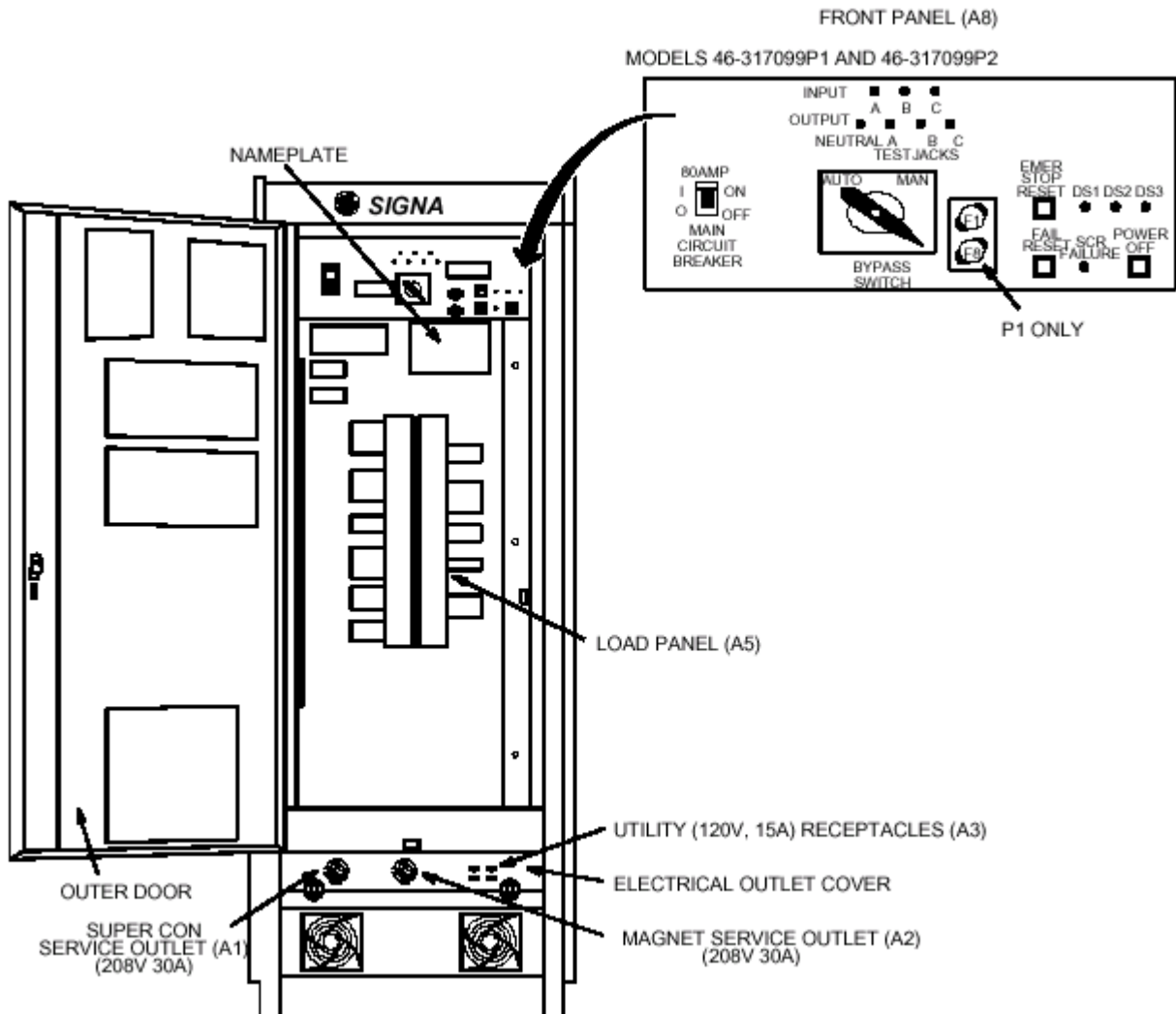

COMPACT PDU FRONT PANEL SWITCH AND TEST POINT LOCATION
 ILLUSTRATION 5-5

5-4-2 Powertech Regulator (continued)



BE SURE THE REGULATOR IS POWERED DOWN AND INPUT POWER TO THE REGULATOR IS PROPERLY LOCKED AND TAGGED OUT!! YOUR LIFE COULD DEPEND ON IT!!

4. Vacuum all dust from exterior and interior of Regulator.
5. Inspect SCR fuse links for discoloration or roughness and replace as necessary.
6. Inspect Snubber circuit boards for discoloration and/or damage to the circuit foil.
7. Check connections on SCR assemblies (fuse links and tap cables), and retighten as necessary. See Illustration 5-6.

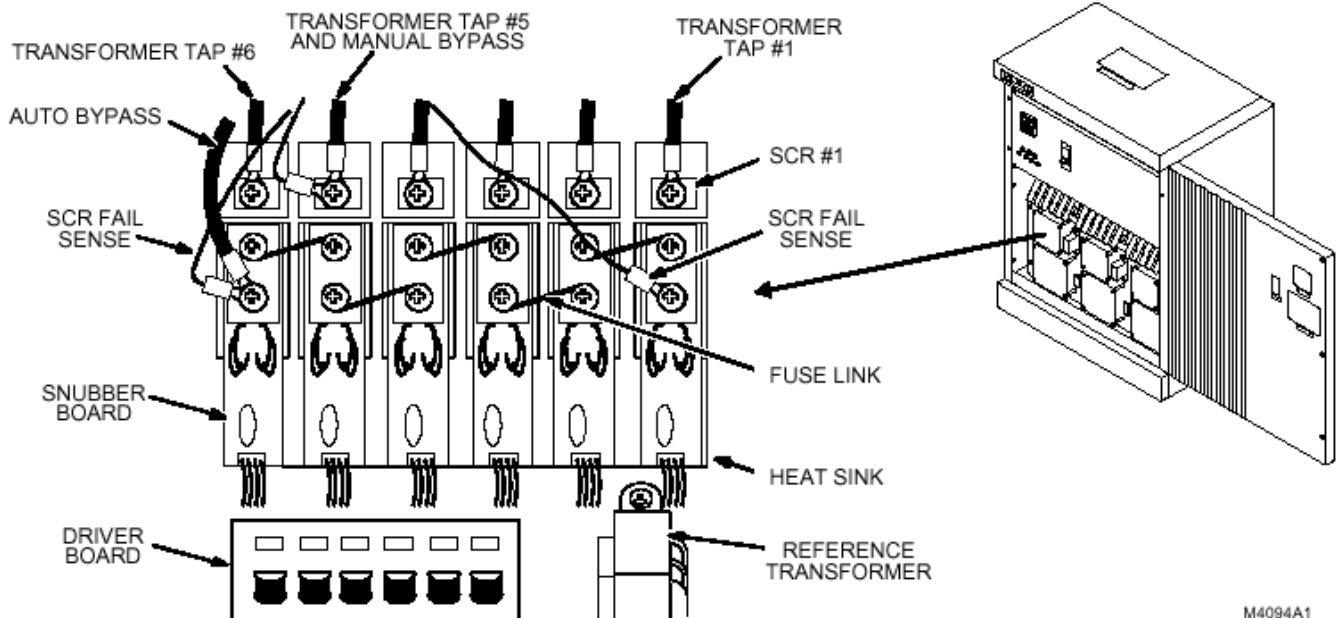

REGULATOR SCR ASSEMBLIES AND SNUBBER BOARDS
 ILLUSTRATION 5-6

M4094A1

8. Check security of connections at the transformer from rear of unit (Primary, Secondary, Ground and Neutral.)

5-4-3 Check Powertech Suppressor/Filter



BE SURE INPUT POWER TO THE SUPPRESSOR/FILTER IS PROPERLY LOCKED AND TAGGED OUT!! YOUR LIFE COULD DEPEND ON IT!!

1. If there is not a Powertech Suppressor/Filter, continue with Section 5-4-4.
2. Check connections at the Supply, Load, and Ground terminals.
3. Recheck the three current loops to assure that phases are still within the following ranges per applicable model of Powertech Suppressor/Filter: (record the readings to monitor degradation over time.)

R4502NA 14-20 AMPS	R4502ND 11-16 AMPS	R4502NE 14-20 AMPS	R4502NN 14-20 AMPS	R4502NB 27-35 AMPS	R4502NF 27-35 AMPS	R4502NG 13-19 AMPS	R4502NH 13-19 AMPS	R4502NX 20-31 AMPS	R4502NZ 11-16 AMPS
--------------------------	--------------------------	--------------------------	--------------------------	--------------------------	--------------------------	--------------------------	--------------------------	--------------------------	--------------------------

5-4-4 Check Powertech Regulator Voltages and Blower

1. Power up the PowerTech regulator set to auto mode, and under system load, check the output voltage at the 100:1 scaled test points (refer to illustration 5-4 and 5-5) for proper line to neutral settings as follows:
 - 208V output - acceptable range is 1.17 - 1.23V.
 - 480V output - acceptable range is 2.70 - 2.84V.

In the event that voltage at test points is not within acceptable range, refer to Appendix H for corrective regulator adjustment procedure.



LETHAL VOLTAGES ARE PRESENT WITHIN THE REGULATOR.

Note

Regulators in Mobile Systems and Regulators installed in the PDU are open at the top and do not have blowers. Do not perform step 2 on Mobile Systems or on systems with the Regulator installed in the PDU.

2. For fixed site free standing PowerTECH regulators, verify blower is operating by reaching over top and behind PowerTECH and checking for air flow. Replace blower (46-307819P1), if necessary.
3. If present, verify Transtector green lights for all three phases are ON.

5-5 CHECK COMPACT PDU FANS AND FILTERS

1. Remove four screws holding the fan panel to the frame and remove the panel. See Illustration 5-7.
2. Remove fan mounting screws and remove fan guard and fan.
3. Remove aluminum fan filters and clean.
4. Inspect fans to see that they are clean and rotors turn freely.

Note

Make sure that fan blows into the PDU when installing fan in assembly

5. Reassemble and install the fan panel.

5-5 CHECK COMPACT PDU FANS AND FILTERS (continued)

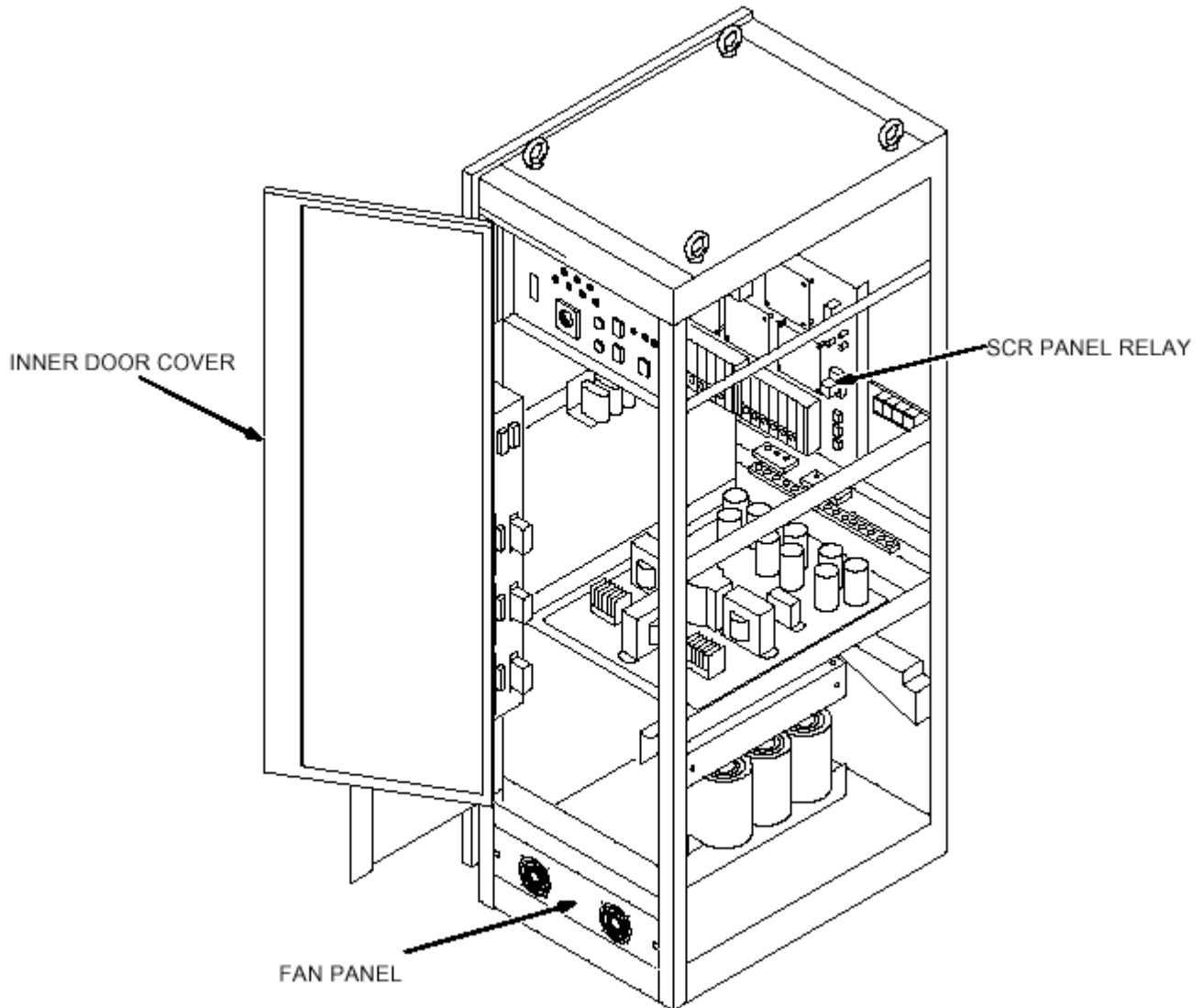

COMPACT PDU
ILLUSTRATION 5-7

5-6 CHECK COMPACT PDU EMERGENCY OFF AND STOP CIRCUITS/INDICATOR LIGHTS

Note

Because this procedure requires the PDU to be shut off, the following procedures should be performed at the same time:

- Perform PAC-II Leakage Current Test (Section 1-3)
- Inspect Compact PDU Power Connections (Section 5-7)

1. Perform System Shutdown. **Refer to Appendix B.**
2. Press one of the EMERGENCY STOP buttons:
 - Operator Console or Operator Workspace Keyboard
 - Magnet Enclosure front cover (two buttons - left and right)
3. See Illustration 5-8. At the PDU Load Center, verify that the RF, Gradient, and Penetration Cabinet circuit breakers trip.
4. Reset the circuit breakers by turning them OFF, then back ON.
5. Repeat steps 2 through 4 for each of the other EMERGENCY STOP buttons.
6. Press one of the following EMERGENCY OFF buttons:
 - Near computer equipment room door.
 - Near magnet room door.
 - On main power disconnect.
7. Verify that the Main Power Disconnect at the PDU goes OFF.
8. Reset Main Power Disconnect at PDU by turning it OFF, then back ON.
9. Repeat steps 6 through 8 for other EMERGENCY OFF buttons.

5-6 CHECK COMPACT PDU EMERGENCY OFF AND STOP CIRCUITS/INDICATOR LIGHTS (continued)

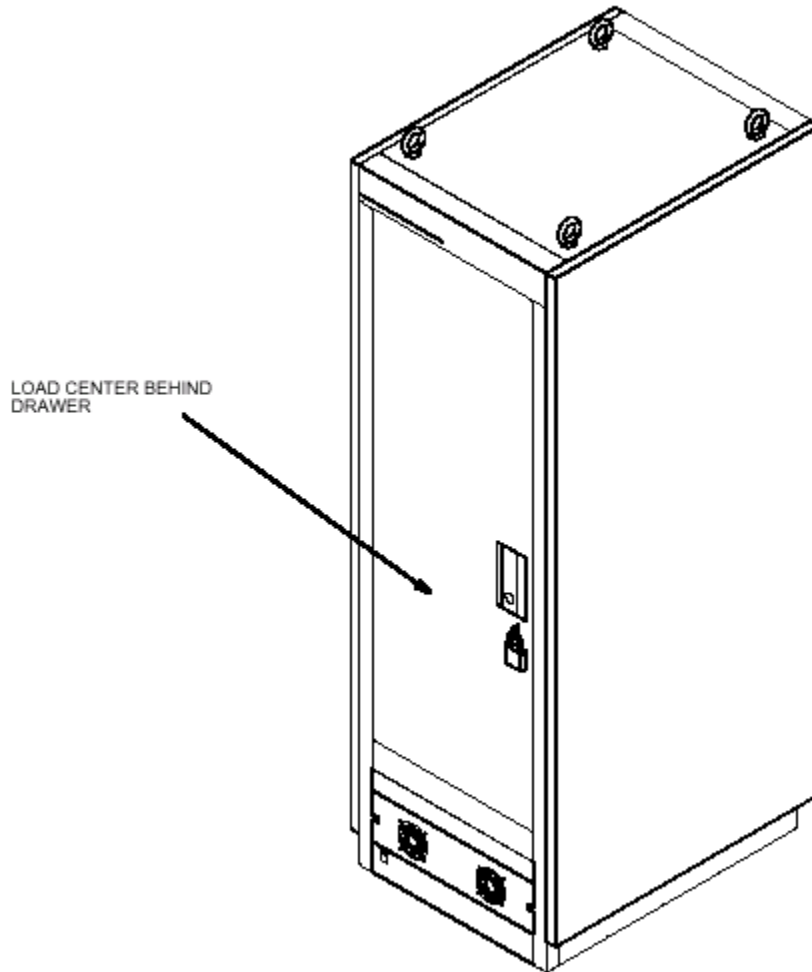

COMPACT PDU LOAD CENTER
ILLUSTRATION 5-8



Potential shock hazard. Signa must be shutdown and cabinets powered OFF before replacing any PDU pushbutton switches.

10. Verify that all bulbs used to backlight PDU pushbutton switches are operational. Replace pushbutton switch 46-307819P36, if necessary.

5-7 INSPECT COMPACT PDU AND POWER CONNECTIONS



SHOCK HAZARD! USE A DIGITAL VOLT METER (DVM) TO VERIFY POWER IS OFF BEFORE WORKING INSIDE COMPACT PDU.

Note

Complete section 5-7 only if you cannot verify it has been done at least once since the installation or any upgrade involving modifications (circuit breaker or power cable changes) to the PDU.

1. Turn OFF and lock out power to the PDU at main power disconnect.
2. Verify that input power to PDU has been disconnected and locked off.
3. Open front door of PDU.
4. Remove 10 screws from inner door and remove cover from door. See Illustration 5-7.
5. Clean inside PDU. Vacuum any dust accumulation.
6. Inspect circuit boards for evidence of overheating, physical damage, and corroded connections. Replace any board that is damaged.
7. Inspect the Ty-wrap adhesive anchors to ensure they have not separated from the sheet metal panels, i.e. the AC wiring harness behind the front circuit breaker panel. Replace as necessary.
8. Check circuit breaker connections and tighten as necessary, then reinstall cover.
9. Check input and output power connections at terminal block on back wall of cabinet and tighten as necessary.
10. Check six main circuit breaker connections and tighten as necessary.
11. Check transformer connections in base of cabinet and tighten as necessary.
12. Check Line and Load connections on filter panel and tighten as follows:
 - Model 46-317099P1: use a flat head screwdriver.
 - Model 46-317099P2: use a 3/8-in. Allen socket.
13. Check SCR's and tighten screws as necessary.
14. Close inner door and tighten inner door retaining screws.
15. Close front door of PDU.

5-8 CHECK TEAL PDU MODULE IN RF/PDU CABINET EMERGENCY OFF AND STOP CIRCUITS

Note

Because this procedure requires the PDU to be shut off, the following procedures should be performed at the same time:

- Perform PAC-II Leakage Current Test (Section 1-3)
- Inspect Teal PDU Power Connections (Section 5-9)

1. Perform System Shutdown. **Refer to Appendix B.**
2. Press one of the EMERGENCY STOP buttons:
 - Operator Workspace Keyboard
 - Magnet Enclosure front cover (two buttons - left and right).
3. At the PDU Load Center, verify that the SGD1, SGD2, and RF AMP PEN Functions circuit breakers trip. See Illustration 5-9.
4. Reset the circuit breakers by turning them OFF, then back ON.
5. Press EMO Reset button.
6. Repeat steps 2 through 4 for each of the other EMERGENCY STOP buttons.
7. Press one of the following EMERGENCY OFF buttons:
 - Near computer equipment room door.
 - Near magnet room door.
 - Power OFF button.
8. Verify that the Input circuit at the PDU trips.
9. Reset the Input circuit at PDU by turning it OFF, then back ON.
10. Repeat steps 7 through 9 for other EMERGENCY OFF buttons.

5-8 CHECK TEAL PDU MODULE IN RF/PDU CABINET EMERGENCY OFF AND STOP CIRCUITS
(continued)

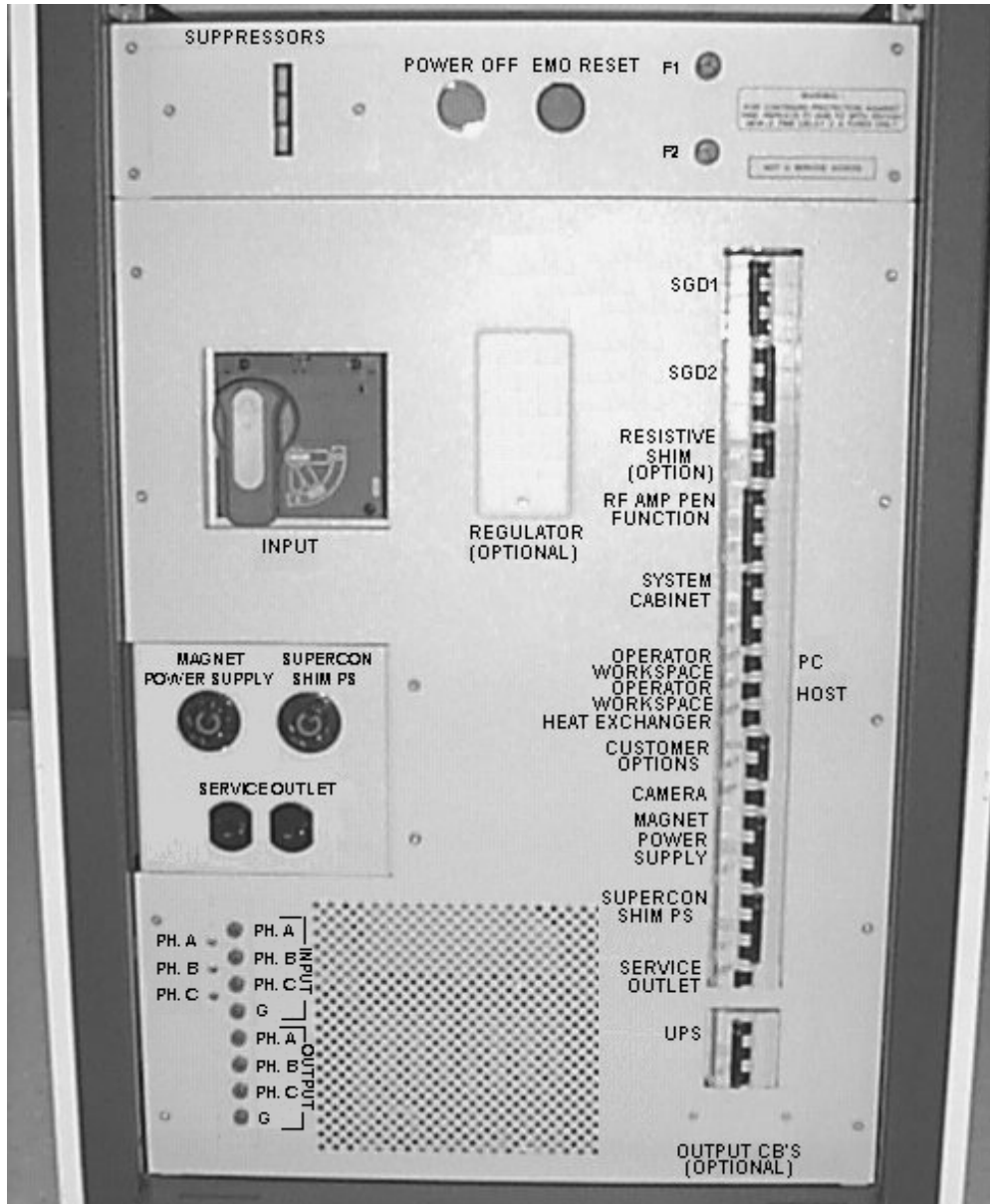

PDU FRONT DETAIL
ILLUSTRATION 5-9

5-9 INSPECT TEAL PDU POWER CONNECTIONS



SHOCK HAZARD! USE A DIGITAL VOLT METER (DVM) TO VERIFY POWER IS OFF BEFORE WORKING INSIDE PDU.

1. Turn OFF and lock out power to the PDU at main disconnect control, A1 Contactor.
2. Verify that input power to PDU has been disconnected and locked off.
3. Open rear cover of RF/PDU Cabinet.
4. Remove PDU module rear power connections protective covers.
5. Check input and output power connections at terminal blocks on back wall of PDU Module and tighten as needed.
6. Re-install protective covers on rear of PDU module.
7. Replace rear cover of the RF/PDU Cabinet.

5-10 CHECK PDU MODULE IN ACGD CABINET EMERGENCY OFF AND STOP CIRCUITS

Note

Because this procedure requires the PDU to be shut off, the following procedures should be performed at the same time:

- Perform PAC-II Leakage Current Test (Section 1-3)
- Inspect ACGD PDU Power Connections (Section 5-11)

1. Perform System Shutdown. **Refer to Appendix B.**
2. Press one of the EMERGENCY STOP buttons:
 - Operator Workspace Keyboard
 - Magnet Enclosure front cover (two buttons - left and right).
3. At the PDU Load Center, verify that the ACGD 208, ACGD Aux, and RF AMP PEN Functions circuit breakers trip. See Illustration 5-9.
4. Reset the circuit breakers by turning them OFF, then back ON.
5. Press EMO Reset button.
6. Repeat steps 2 through 4 for each of the other EMERGENCY STOP buttons.
7. Press one of the following EMERGENCY OFF buttons:
 - Near computer equipment room door.
 - Near magnet room door.
 - Power OFF button.
8. Verify that the Input circuit at the PDU trips.
9. Reset the Input circuit at PDU by turning it OFF, then back ON.
10. Repeat steps 7 through 9 for other EMERGENCY OFF buttons.

5-10 CHECK PDU MODULE IN ACGD CABINET EMERGENCY OFF AND STOP CIRCUITS
 (continued)

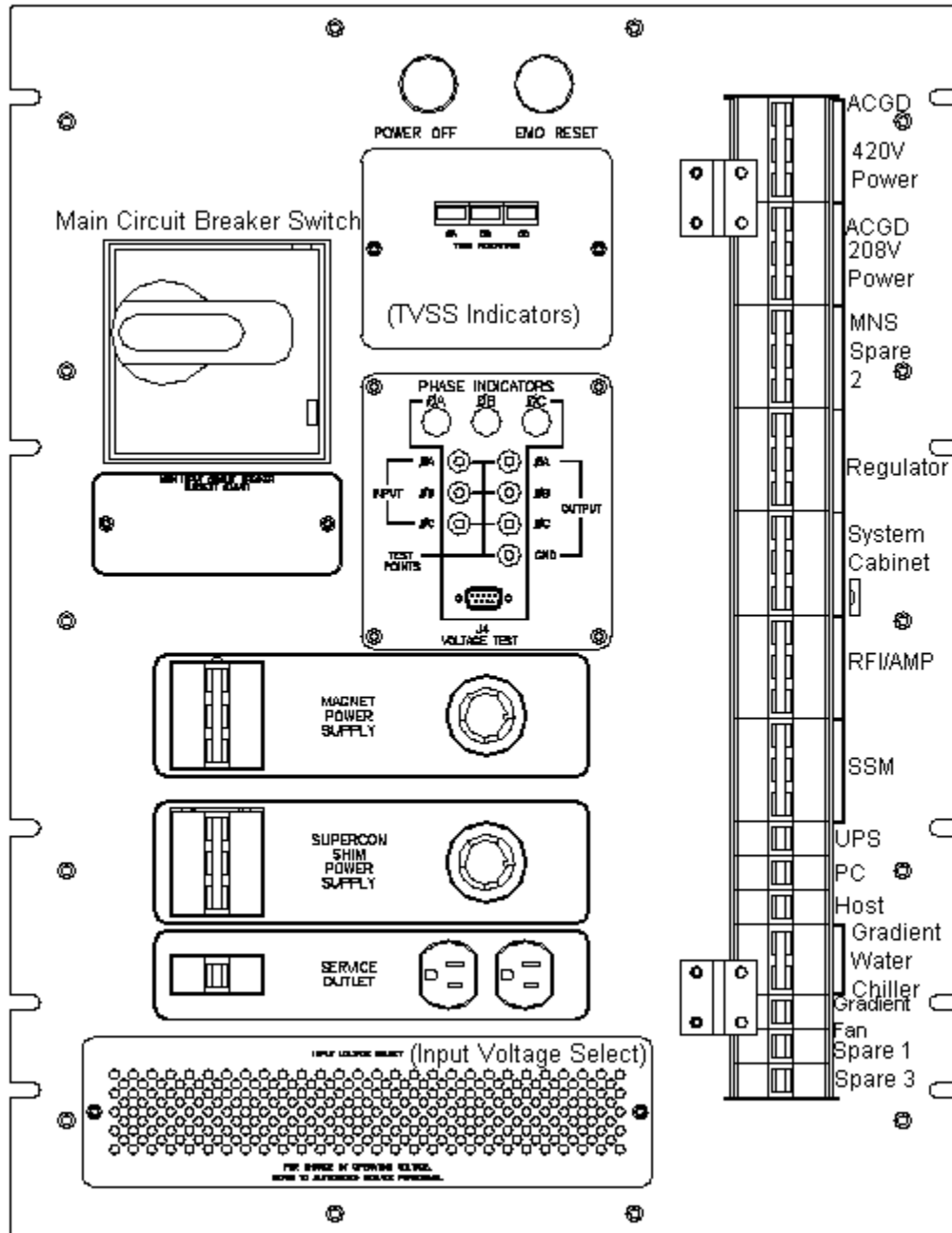

ACGD CABINET PDU FRONT DETAIL
 ILLUSTRATION 5-10

5-11 INSPECT THE ACGD CABINET PDU POWER CONNECTIONS



SHOCK HAZARD! USE A DIGITAL VOLT METER (DVM) TO VERIFY POWER IS OFF BEFORE WORKING INSIDE PDU.

1. Place the Main Circuit Breaker Switch to the OFF position, lock and tag the breaker.
2. Using a voltmeter or other voltage indicating device, check the voltage at the Main Input Terminal Board to be sure that no voltage is being applied to the input of the PDU.
3. Open rear cover of ACGD Cabinet.
4. Remove PDU module rear power connections protective covers.
5. Check input and output power connections at terminal blocks on back wall of PDU Module and tighten as needed.
6. Re-install protective covers on rear of PDU module.
7. Replace rear cover of the ACGD Cabinet.
8. Remove the lock from the Main Circuit Breaker and place switch in the ON position.