

SECTION 2 - RF

TABLE OF CONTENTS

<u>SECTION</u>	<u>TITLE</u>	<u>PAGE</u>
2-1	CHECK RF CABINET FANS AND FILTERS	2-2
2-2	CLEAN AND INSPECT ERBTEC AMPLIFIER	2-11
	2-2-1 Functional Check	2-13
2-3	PERFORM POWER MONITOR FUNCTIONAL CHECKS—RF/PEN CABINET	2-15
	2-3-1 Tools And Instruments Required	2-15
	2-3-2 Hardware Preparation	2-16
	2-3-3 Head Checks	2-21
	2-3-4 Body Checks	2-29
	2-3-5 Amplifier Shutdown Verification	2-38
	2-3-6 Declaration Form Preparation	2-41
	2-3-7 System Restoration	2-42
2-4	PERFORM POWER MONITOR FUNCTIONAL CHECKS—RF/PEN II CABINET	2-43
	2-4-1 Tools And Instruments Required	2-43
	2-4-2 Hardware Preparation	2-44
	2-4-3 Body Checks	2-52
	2-4-4 Head Checks	2-58
	2-4-5 Amplifier Shutdown Verification	2-66
	2-4-6 Declaration Form Preparation	2-68
	2-4-7 Restoration Check List	2-69
2-5	PERFORM POWER MONITOR FUNCTIONAL CHECKS—Solid State RF & RF/PDU CABINET	2-71
	2-5-1 Tools And Instruments Required	2-72
	2-5-2 Hardware Preparation	2-73
	2-5-3 Body Checks	2-76
	2-5-4 Head Checks	2-85
	2-5-5 Amplifier Shutdown Verification	2-95
	2-5-6 System Restoration	2-97
	2-5-7 Declaration Form Preparation List	2-98
2-6	CHECK RF OUTPUT POWER	2-99

2-1 CHECK RF CABINET FANS AND FILTERS**RF/Pen Cabinet Filter Replacement**

The RF/Pen cabinet has replaceable air filters. When replacing air filters, make sure that new filters are the same as the old ones, since there is more than one size. See Illustration 2-1.

1. Turn recessed screw at top center of cover 1/4-turn counterclockwise to release cover latch.
2. Tilt top of cover forward and lift up and out to remove cover for access to filter(s) (2160200-44).
3. Remove four screws and lockwashers holding both filters on inside of cover.
4. For RF amplifier filter (2124496-34), slide filter up and out.
5. Inspect filter for dust build-up and replace as required.
6. For RF amplifier filter, insert filter into blower frame keeping intake side (side with cleaning instructions) facing out.
7. For front panel filters, insert filter into panel frame keeping intake side (side with cleaning instructions) facing out. Install four screws. Secure filter in front cover using lockwashers and screws.
8. Probe MEPS Fans (2124498-18) with a small ty-wrap to make sure they are operating.
9. Replace cover on cabinet by inserting lower cover lip behind trim strip at bottom of cabinet and swinging top of cover into spring loaded "slam-latch."

RF/PEN CABINET
21009930 MODELS

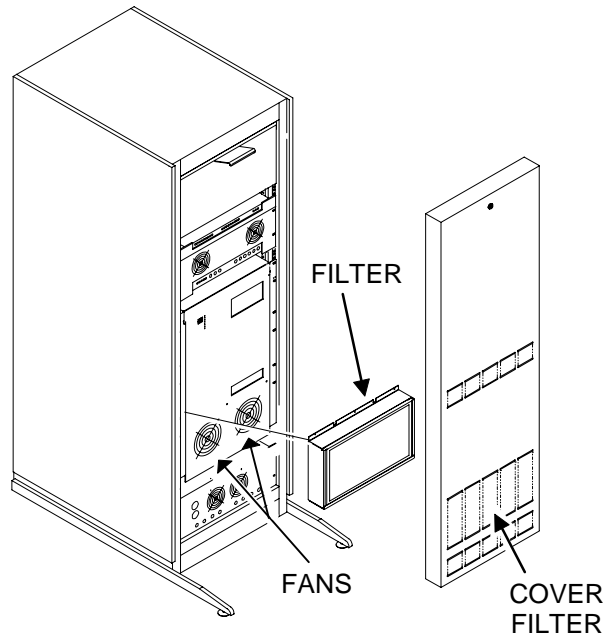

RF/PEN CABINET FILTER & FAN LOCATIONS
ILLUSTRATION 2-1

2-1 CHECK RF CABINET FANS AND FILTERS (continued)

RF/Pen II Cabinet Filter Replacement

When replacing air filters, be sure to use GE part number 2160200-44. See Illustration 2-2.

1. Turn the recessed screw at the top center of the door 1/4 turn counterclockwise to release the cover latch.
2. Tilt the top of the door forward, and lift up and out to remove the door for access to the filter(s).
3. Remove each filter by lifting up slightly and pulling bottom edge outward.
4. Inspect the filter for dust build-up, and replace as required.
5. Insert the filters first up and into the top bracket, then drop down into lower bracket, keeping the intake side (side with cleaning instructions) facing the door.
6. Probe Fans (2160200-14) with a small ty-wrap to make sure they are operating.
7. Replace the front cover on the cabinet by inserting the lower cover lip behind the shoulder bolts at the bottom of the cabinet and swinging the top of the door into the spring loaded "slam-latch".

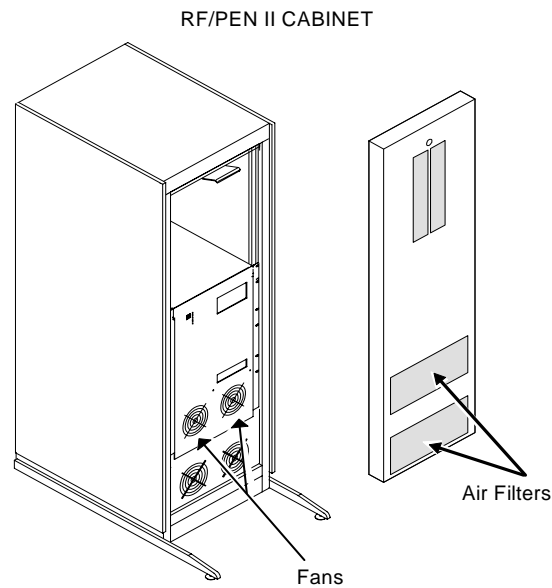

RF/PEN II CABINET FILTER & FAN LOCATION
 ILLUSTRATION 2-2

2-1 CHECK RF CABINET FANS AND FILTERS (continued)**RF/PDU Cabinet**

When replacing air filters, be sure to use GE part number 2160200-44. See Illustration 2-3.

1. Turn the recessed screw at the top center of the front cover 1/4 turn counterclockwise to release the cover latch.
2. Tilt the top of the front cover forward, and lift up and out to remove the cover for access to the filter(s).
3. Remove each filter by lifting up slightly and pulling bottom edge outward.
4. Inspect the filter for dust build-up, and replace as required.
5. First insert the filters up and into the top bracket, then drop down into lower bracket, keeping the intake side (side with cleaning instructions) facing the door.
6. Probe Fans (2195572), on the rear of both RF Amplifiers, with a small ty-wrap to make sure they are operating. See Illustration 2-4.
7. Replace the front cover on the cabinet by inserting the lower cover lip behind the shoulder bolts at the bottom of the cabinet and swinging the top of the door into the spring loaded "slam-latch".

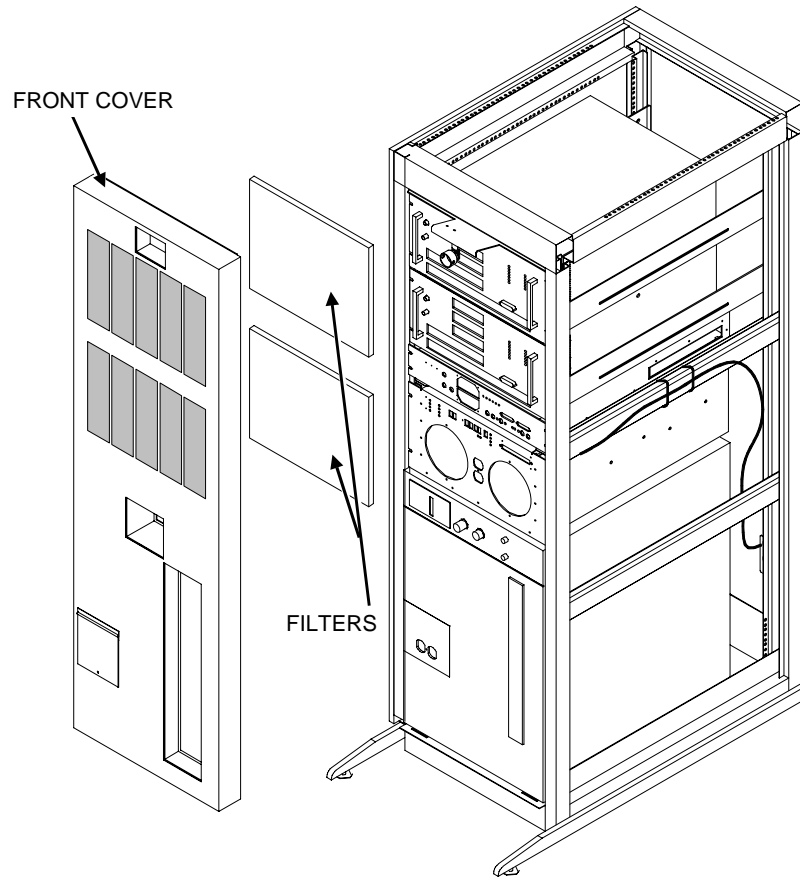

RF/PDU CABINET COVERS AND FILTER LOCATIONS
ILLUSTRATION 2-3

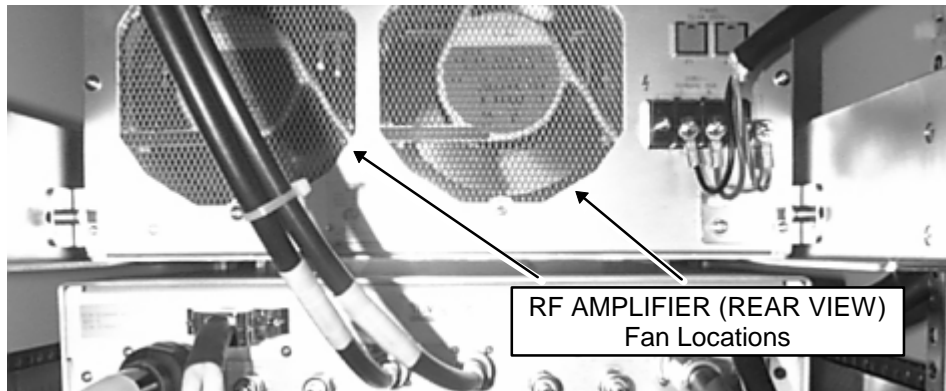

RF AMPLIFIER FAN LOCATIONS
ILLUSTRATION 2-4

2-1 CHECK RF CABINET FANS AND FILTERS (continued)

SRF 1.5T & 1.0T Cabinet

When replacing air filters, be sure to use GE part number 2284074. See Illustration 2-5.

1. Turn the recessed screw at the top center of the front cover 1/4 turn counterclockwise to release the cover latch.
2. Tilt the top of the front cover forward, and lift up and out to remove the cover for access to the filter(s).
3. Remove each filter by lifting up slightly and pulling bottom edge outward.
4. Inspect the filter for dust build-up, and replace as required.
5. First insert the filters up and into the top bracket, then drop down into lower bracket, keeping the intake side (side with cleaning instructions) facing the door.
6. Probe Fans (2176114, 1.5T or 2195572, 1.0T), on the front of both RF Amplifiers (rear of Amplifiers for 1.0T), with a small ty-wrap to make sure they are operating. See Illustration 2-6 for the 1.5T and Illustration 2-4 for the 1.0T.
7. Replace the front cover on the cabinet by inserting the lower cover lip behind the shoulder bolts at the bottom of the cabinet and swinging the top of the door into the spring loaded "slam-latch".

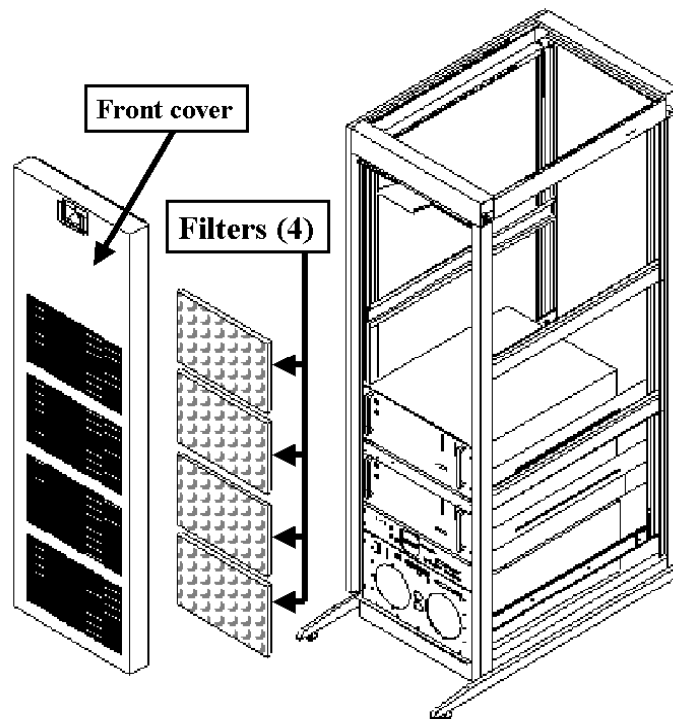

1.5T & 1.0T SRF CABINET FRONT COVER & FILTER LOCATION
 ILLUSTRATION 2-5

2-1 CHECK RF CABINET FANS AND FILTERS (continued)

FRONT VIEW

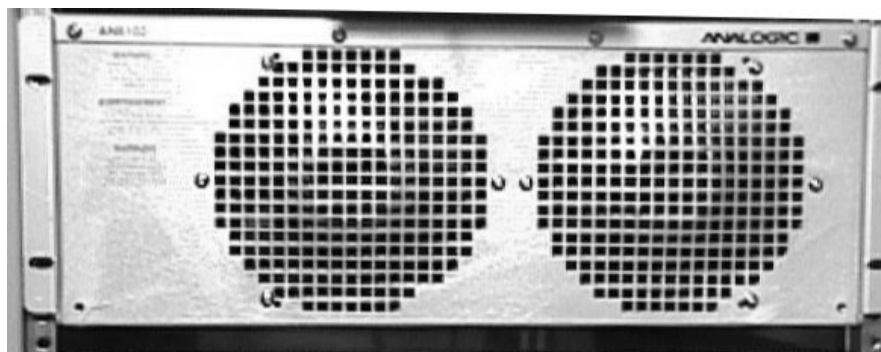

1.5T ANALOGIC RF AMPLIFIER FAN LOCATIONS
ILLUSTRATION 2-6

2-1 CHECK RF CABINET FANS AND FILTERS (continued)**1.5T SRFD II Cabinet**

When replacing air filters, be sure to use GE part number 2284074. See Illustration 2-7.

1. Turn the recessed screw at the top center of the front cover 1/4 turn counterclockwise to release the cover latch.
2. Tilt the top of the front cover forward, and lift up and out to remove the cover for access to the filter(s).
3. Remove each filter by lifting up slightly and pulling bottom edge outward.
4. Inspect the filter for dust build-up, and replace as required.
5. First insert the filters up and into the top bracket, and then drop down into lower bracket, keeping the intake side (side with cleaning instructions) facing the door.
6. Probe the four (4) Fans (2262478), on the rear of the SRFD II Module, with a small ty-wrap to make sure they are operating. See Illustration 2-7.
7. Replace the front cover on the cabinet by inserting the lower cover lip behind the shoulder bolts at the bottom of the cabinet and swinging the top of the door into the spring loaded "slam-latch".

2-1 CHECK RF CABINET FANS AND FILTERS (continued)

1.5T SRFD II Cabinet

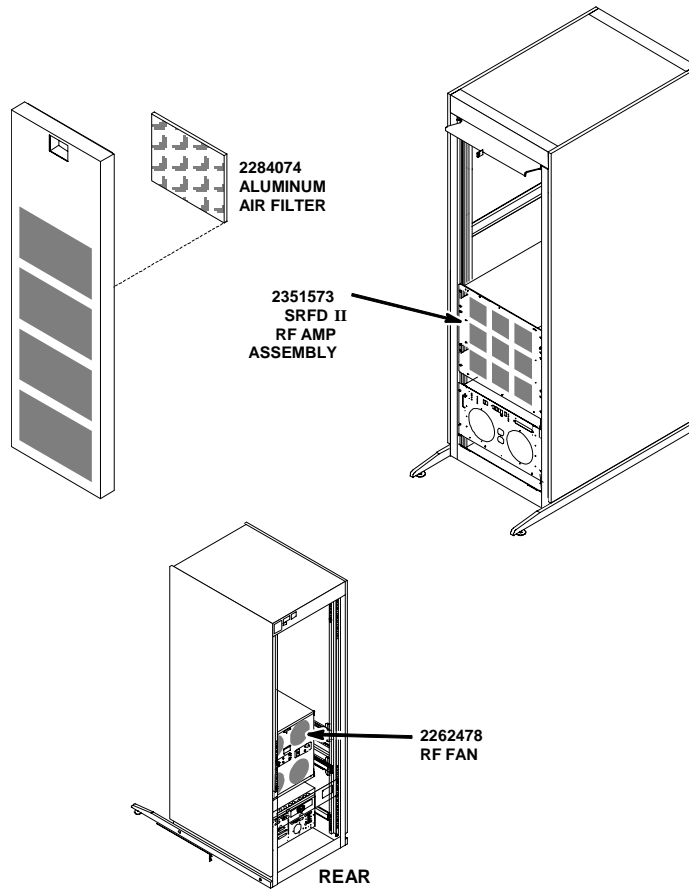

1.5T SRFD II CABINET FILTER & FAN LOCATIONS
ILLUSTRATION 2-7

2-2 Clean and Inspect Erbtec Amplifier (Does not apply to solid state amplifiers in RF/PDU Cabinet)

Note

Frequency of cleaning - The routine described here should be performed at least once a year. If operating with unfiltered air, high humidity, or in an atmosphere heavy in particulates (dust, paint, aerosol sprays, etc.), this routine should be performed more frequently.

1. Turn off the circuit breaker CB1, and unplug the amplifier main power cord.



If the amplifier has recently been in a power-on mode (including Standby), wait several minutes before continuing (to allow capacitors to discharge).

2. Remove all side panel screws (Illustration 2-8 and Illustration 2-9). Remove all three side panels (two panels on right side).

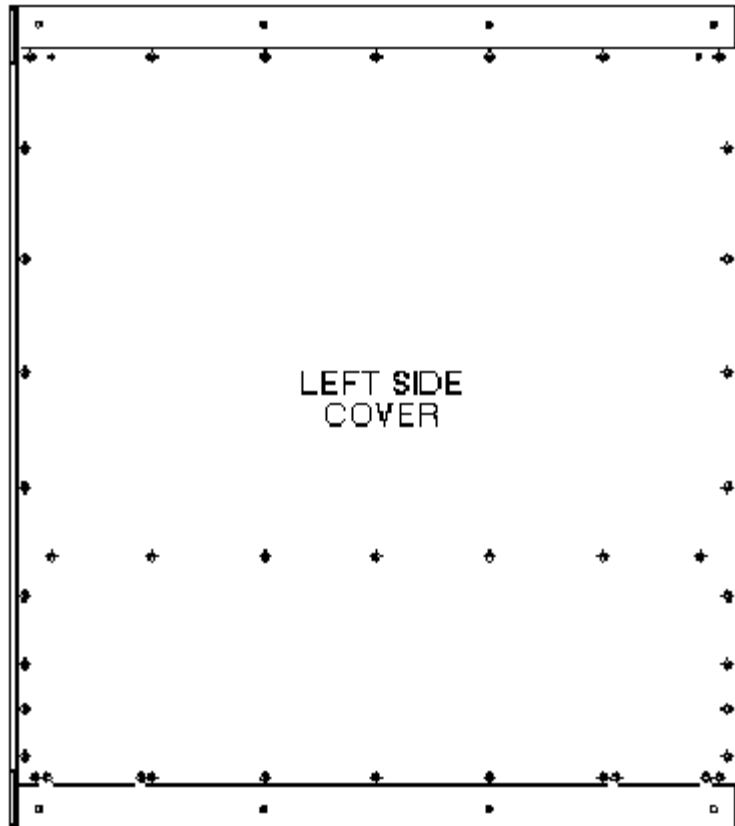

LEFT SIDE COVER
ILLUSTRATION 2-8

2-2 Clean and Inspect Erbtec Amplifier (Does not apply to solid state amplifiers in RF/PDU Cabinet)
(continued)

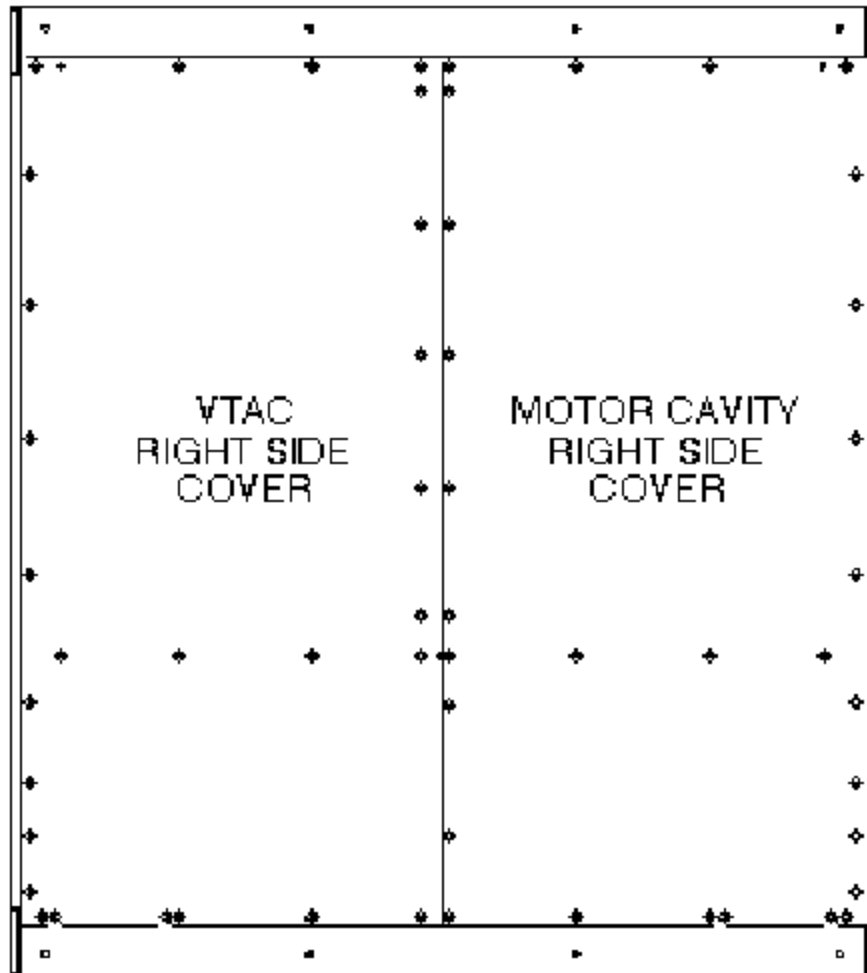

RIGHT SIDE COVERS
ILLUSTRATION 2-9

- 3. Blow out the entire amplifier (all cavities) with dry compressed air to completely remove all particulates taken in by the fans. Particulate build-up can provide an electrical path for high voltage arcing.



Avoid touching any components with hands or air nozzle.

- 4. Visually inspect the amplifier interior for signs of excessive heating, and for loose parts, screws, and connectors.
- 5. Replace the three side panels.
- 6. Plug in the amplifier main power cord.

2-2-1 Functional Check

1. Check all front panel air vents for obstructions. Air intake occurs at the bottom front of the amplifier. No objects blocking air flow, nor protruding through the fan guard, should be present. Also, ensure a clear path for the exit of warm air through the air exhaust vents, also located on the front panel (Illustration 2-10 or Illustration 2-11).

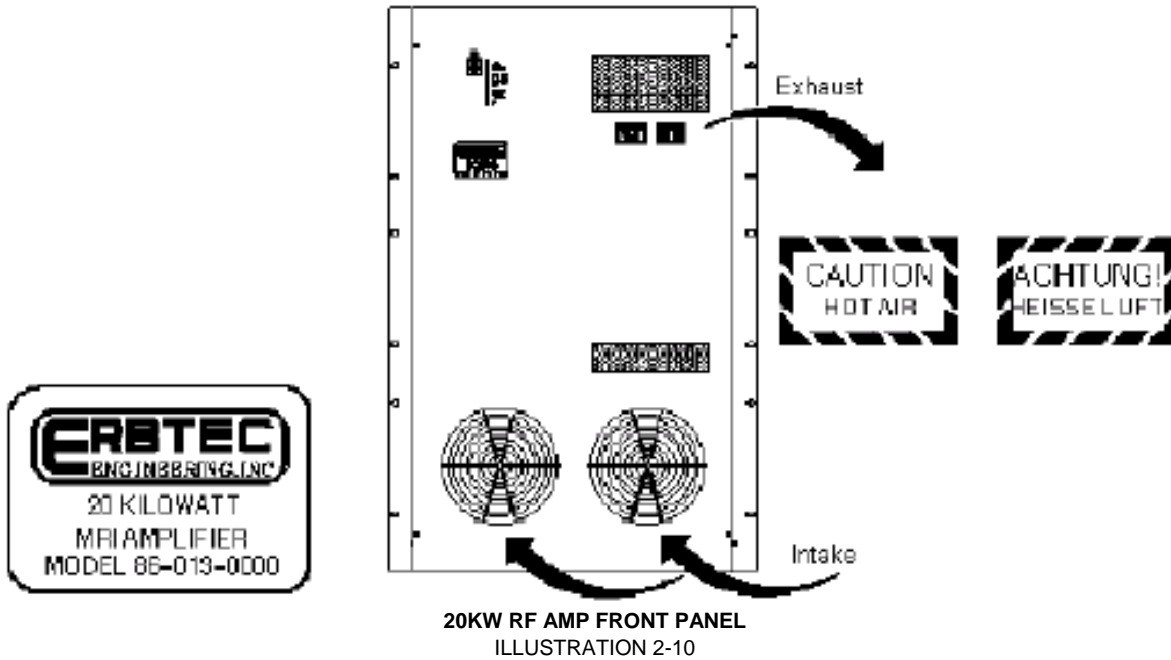

2-2-1 Functional Check (continued)

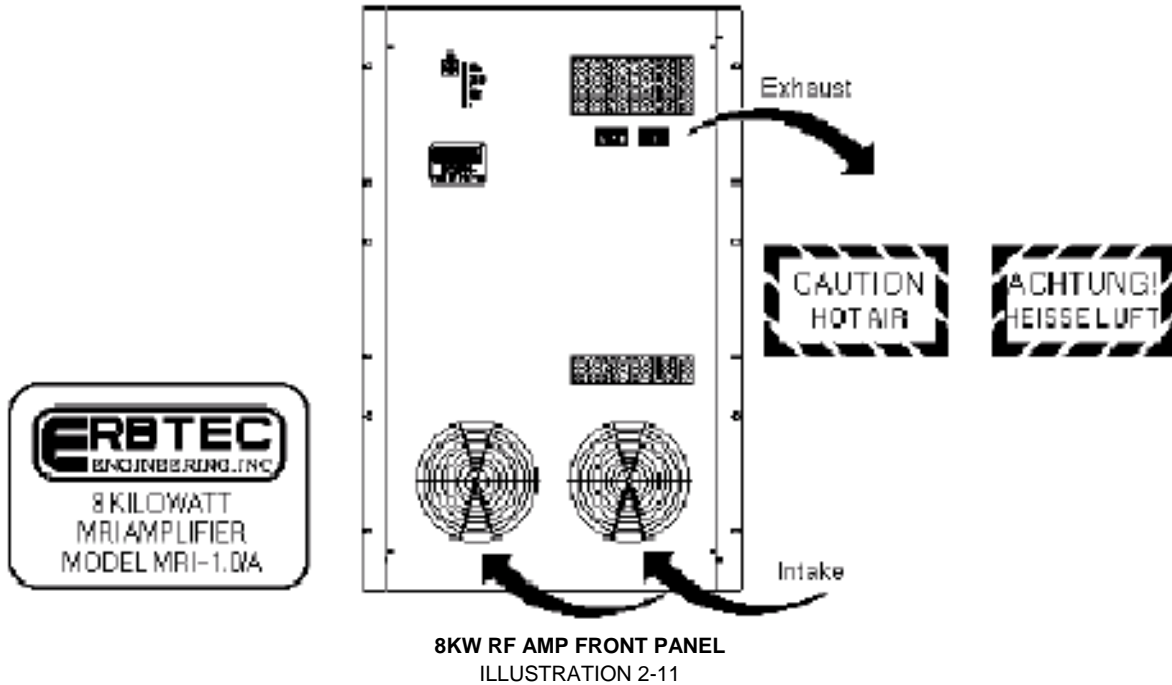

2. While viewing the LED display on the front panel, switch the main circuit breaker CB1, located on the rear of the amplifier, to the ON position.
3. Check to see that all LEDs light for just a moment immediately after breaker CB1 is turned on. Also, immediately after turning on the main breaker, a *kerchunk* sound should be heard as the onboard microprocessor initializes the tuning motors.

If no irregularities are detected, the amplifier will be in an idle state, with the yellow OFF LED and the green BODY LED lit. When this occurs, the amplifier is ready to proceed into a standby condition. This indicates that cleaning and restoration has been performed correctly.

If an error is detected, the amplifier will immediately stop its internal power-on test, turn on the FAULT LED, and issue a fault code on the front panel digital LED display.

Note

Red FAULT Light - If the red FAULT LED is not lit, no fault exists, even though a number may be indicated on the digital LED display.

2-3 PERFORM POWER MONITOR FUNCTIONAL CHECKS—RF/PEN CABINET

Description

This section (written as a continuous procedure) applies to systems installed with the RF/PEN 1 Cabinet (contains the RFSC and the MEPS).

This procedure ensures that the power monitor is fully functional, including redundant trip capability. The tests described use a special pulse sequence data base (PSD) to provide excitation for the RF amplifier. The PSD allows the service engineer to selectively force peak power, pulse width, and duty cycle beyond allowable limits. Setpoints for testing are selected by modifying control variables (CVs) that override the values that are normally calculated and downloaded by the PSD.

Power Monitor firmware operation is changed to bypass/test mode by moving jumpers on the Communications Manager/Power Monitor Board (JP2, JP6). This action permits setpoint verification without tripping the RF amplifier, thereby eliminating the time consuming necessity of resetting the amplifier after each trip.

After setpoints are checked, actual shutdown of the amplifier is verified twice for monitor A (to verify both relay and logic shutdowns), and once for monitor B (connected to amplifier via monitor A). This also confirms that the bypass/test jumper (JP2, JP6) is restored prior to returning the system to normal operation.

2-3-1 Tools and Instruments Required

Oscilloscope: 100 MHz minimum.

Additional tools per Table 2-1 or Table 2-2.

TABLE 2-1
 TOOLS AND INSTRUMENTS REQUIRED (1.0 T AND 1.5T) LX

Item	Description	Part Number	Quantity
A.	RF Power Measurement Kit	46-317724G1 or G2	1
OR	G1 Kit does not contain the Dummy Load: 50 ohm, 200 Watt, 30dB Attenuator - Bird Model 8322	46-255837P10	

TABLE 2-2
 TOOLS AND INSTRUMENTS REQUIRED (1.0 T AND 1.5T) LX

Item	Description	Part Number	Quantity
A.	RF Wattmeter - Bird Thruline Model 4391	46-255837P1	1
B.	10000-watt interchangeable element Bird # 10000B, 1.5T	46-255837P101	1
C.	5000-watt interchangeable element Bird # 5000B, 1.5T	46-255837P105	1
D.	RF Test Cables Kit	46-255816G1	1
E.	50 ohm, 200 Watt, 30dB Attenuator - Bird Model 8322	46-255837P10	1
F.	Attenuator, Fixed 50 ohm, 10 dB	46-258601P3	1
G.	Variable Rotary Attenuator, 10 dB, in 1 dB steps	46-255838P3	1 or 2

2-3-2 Hardware Preparation

Prerequisite calibration procedures listed in Table 2-3 must have been performed in sequence.

TABLE 2-3
PRE-REQUISITE — POWER MONITOR CALIBRATION PROCEDURE LX

Step	Procedure	When Required
1a OR	DUMMY LOAD & CABLES CALIBRATION	When not using the RF Power Measurement Kit and dummy load and cables have not been calibrated.
1b	RF POWER MEASUREMENT CALIBRATION	1.5T Only: Oscilloscope display (less than 300 MHz) must be characterized by performing calibration procedure using the 1.5T Scope Calibrator to compensate for bandwidth limitations (scope roll-off).
2	APB CALIBRATION MAX POWER RF OUT SETUP & CALIBRATION	Initial installation or if RF Amp has been repaired.

Pre-requisite — Signa must be fully functional and properly calibrated.

Pre-requisite — Software must be running with the system capable of normal imaging.

2-3-2 Hardware Preparation (continued)

1. Bypass EFB with a variable attenuator between RFIN, MRIA15J105, and EFB RF OUT, MRIA15J103, on the rear panel of the RF System Controller Module (RFSC). See Illustration 2-12.

Note

EFB is bypassed (with added attenuation) due to the use of square waveforms in this test (spikes on the front end of the RF square pulse could result in false trips).

2. Variable Attenuator set-point:
 - a. Signa Advantage and Horizon Systems — set to 6 dB.
 - b. Lx / 8x Systems — set to 2 dB.

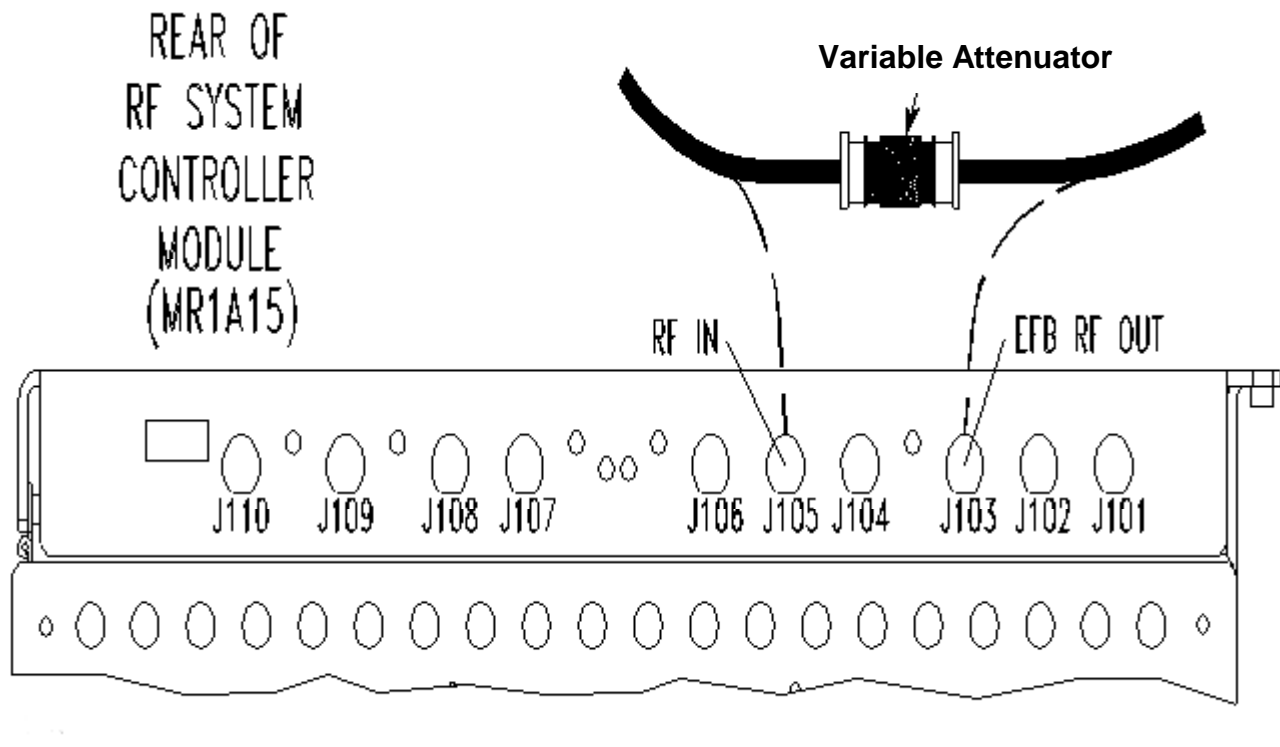

BYPASSING EFB
 ILLUSTRATION 2-12

3. Remove the front cover from the RF/PEN cabinet.
4. Be sure that the monitor interlock switch on the front panel of the RFSC is in "MODE 1" (normal) position.

2-3-2 Hardware Preparation (continued)

- Place the rocker switch on the front panel of the RFSC Module in the ON (T/R-DD Faults Disable) position (bypass/test). The switch color will be red. See Illustration 2-13.

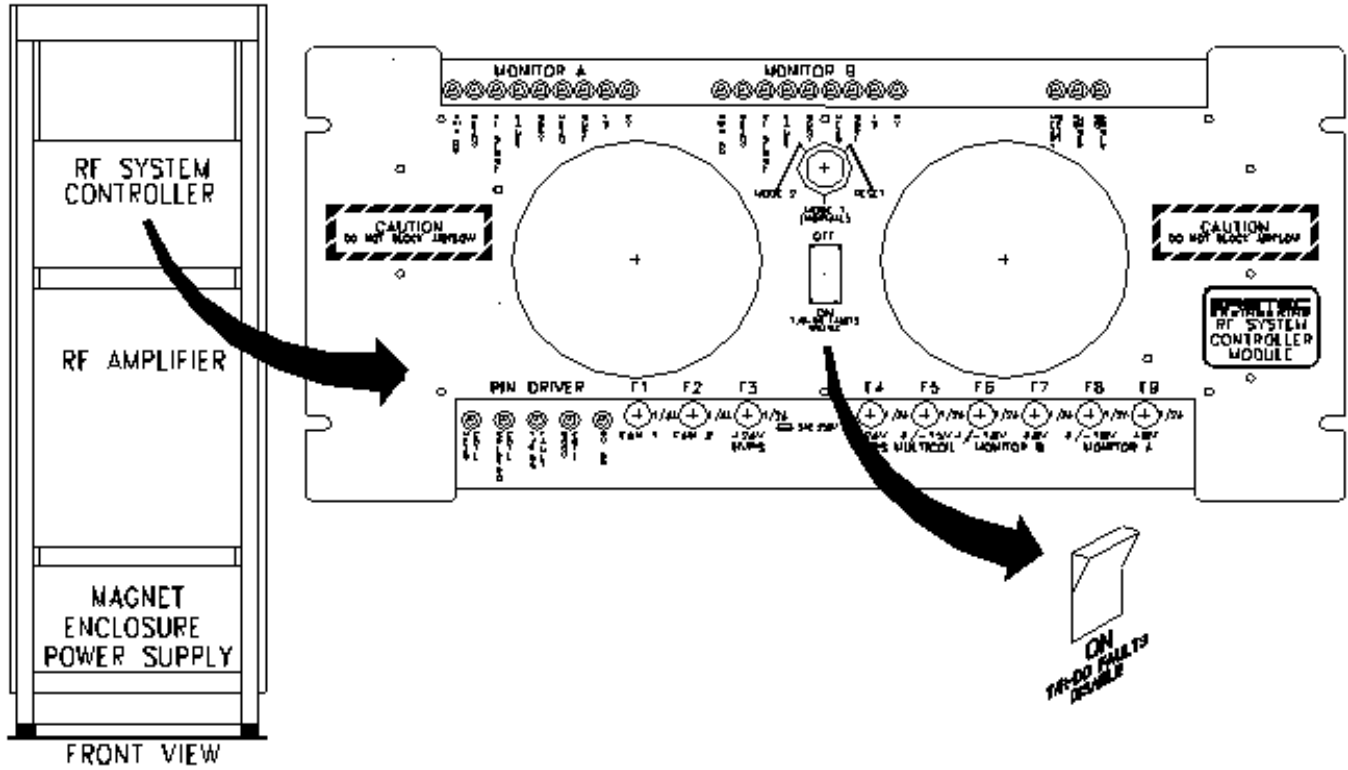

TR AND DD FAULTS DISABLE SWITCH POSITION AT RFSC MODULE
 ILLUSTRATION 2-13

- Remove the four 10-32x1/2 panhead screws and four #10 flat washers securing the RFSC (MRIA15) to the RF/PEN cabinet, and slide out the module.

2-3-2 Hardware Preparation (continued)

7. Loosen the captive screws on the top lid and open. See Illustration 2-14. Do not open bottom cover.
8. Most RFSC Modules have a white High Voltage Enable Switch that must be pulled to the UP position (located near left front of module).

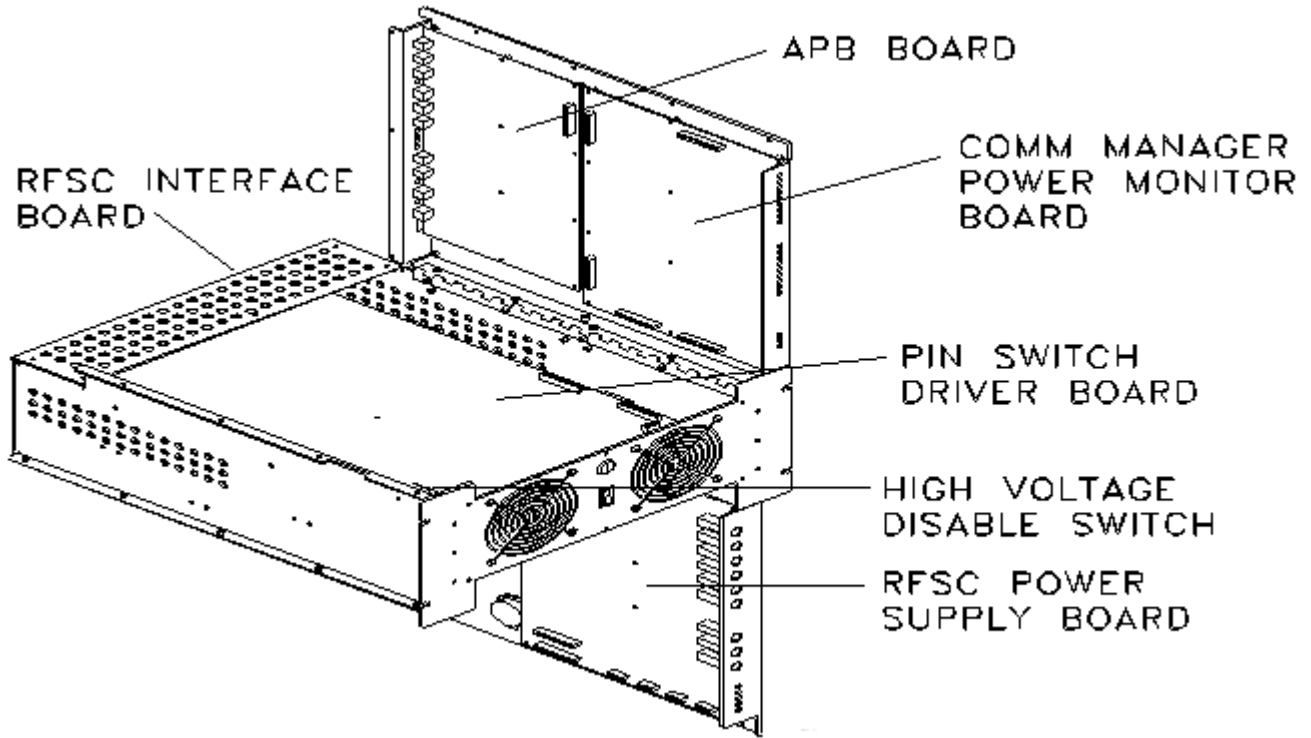

RF SYSTEM CONTROLLER MODULE
ILLUSTRATION 2-14

2-3-2 Hardware Preparation (continued)

- Place jumpers JP2 & JP6 on the Communications Manager/Power Monitor (CM/PM) board in the bypass/test position, "B". See Illustration 2-15.

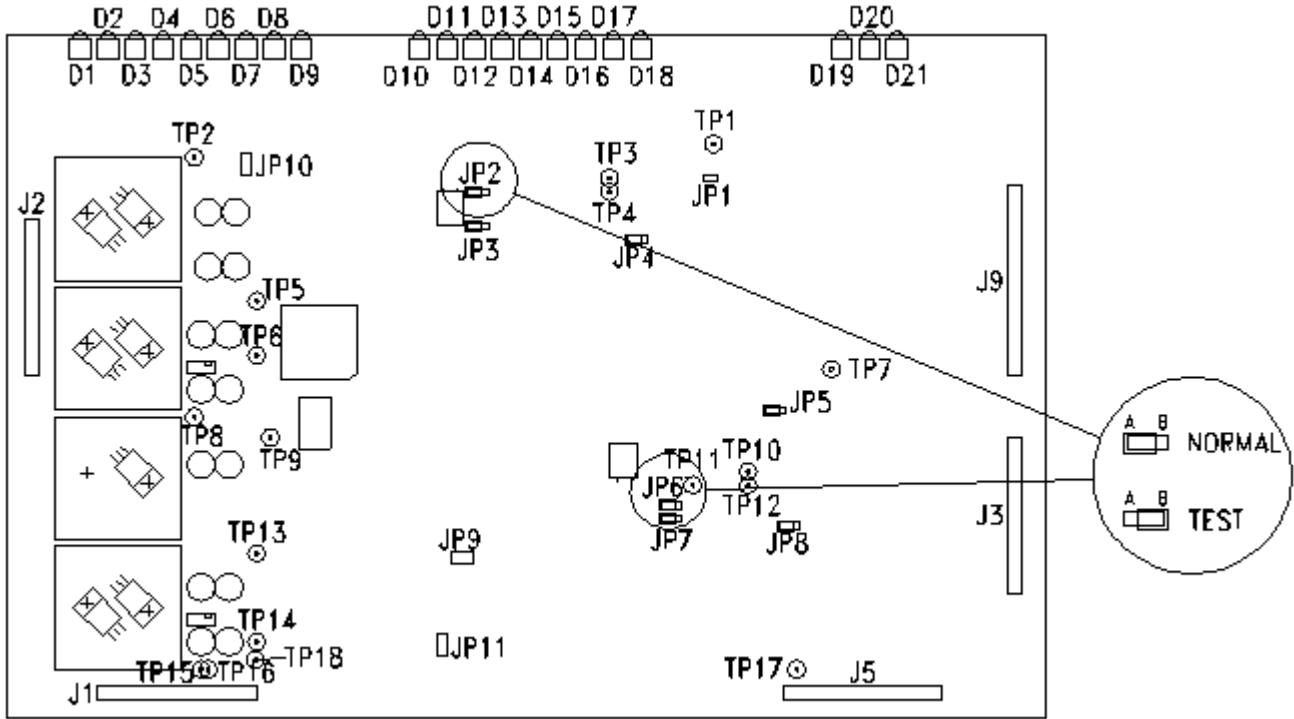

CM/PM BOARD POWER MONITOR JUMPER SETTINGS
 ILLUSTRATION 2-15

Note

Amplifier Tripped While Moving JP2 And JP6: If the amplifier is tripped while moving JP2 and JP6, IPER (In Place Error Recovery) should reset it about three minutes after the fault condition is cleared. If problems are encountered with amplifier operation after such a trip, rebooting Signa may be required to restore proper operation.

- Verify that only the "Power On" LEDs are illuminated for both power monitors (Ready LED off, confirm that JP2 & JP6 are in test/bypass "B" position).

2-3-3 Head Checks

- The following generic Illustration 2-16 has been provided for sites without the RF Power Measurement Kit.

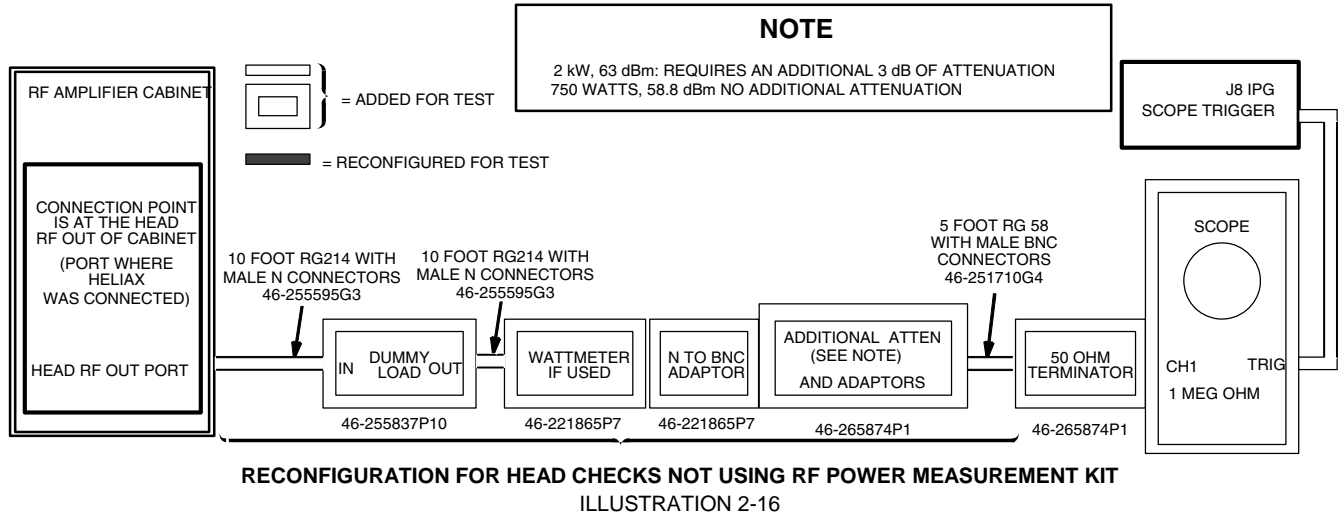

Note

Maximum RF Signal input for any scope is 30 dBm (10 Volts Peak, 20 VPP).

Note

Both the dummy load and the cable that connects the amplifier output to the dummy load input must be calibrated per *DUMMY LOAD AND CABLES CALIBRATION*. See Signa Release 8.X Service Methods CD-ROM. If the cable has not been calibrated, STOP; do not continue with this procedure until cable calibration is complete.

2-3-3 Head Checks (continued)

2. **For 1.5T systems:** Connect per Illustration 2-16 to Head output (J12 at I/F panel / J2 at Head Directional Coupler) of RF/Pen cabinet. If using a wattmeter use the proper element. Or use the RF Power Measurement Kit card # 63 (2 kW, 63 dBm). For 1.5T is necessary to use the 1.5T Scope Calibrator card to compensate for scope bandwidth limitations (frequency roll-off), refer to the Appendix for instructions.

Verify the selectable oscilloscope input termination is 1 Meg ohm when using the RF Power Measurement Kit 50 ohm terminator. Otherwise, the oscilloscope should be 50 ohm termination for all RF measurements.

Note

Calibrate The Amplifier Output To Wattmeter Input Cable - The cable that is used to connect the amplifier output to the wattmeter input must be calibrated per procedure Dummy Load and Cables Calibration. If the cable has not been calibrated, STOP, do not continue with this procedure until ATTEN TEST cable calibration is complete.

Note

A tool is available for use in converting between the following: dBm, VPP, Watts, and Divisions (Divisions is used with 1.5T systems only). This tool is located on the Signa Release 8.X Service Methods CD-ROM under the Tools directory, titled: SCOPECAL.xls.

Path:

[START] [Programs] [Windows Explorer] [Mrservice (drive)] [Tools] [SCOPECAL.xls].

2-3-3 Head Checks (continued)

3. **For 1.0T systems:** Connect per Illustration 2-16 to Head output (J12 at I/F panel / J2 at Head Directional Coupler) of RF/Pen cabinet. If using a wattmeter use the proper element. Or use the RF Power Measurement Kit card # 58 (750 W, 58 dBm).

Verify the selectable oscilloscope input termination is 1 Meg ohm when using the RF Power Measurement Kit 50 ohm terminator. Otherwise, the oscilloscope should be 50 ohm termination for all RF measurements.

Note

Calibrate The Amplifier Output To Wattmeter Input Cable - The cable that is used to connect the amplifier output to the wattmeter input must be calibrated per procedure Dummy Load and Cables Calibration. If the cable has not been calibrated, STOP, do not continue with this procedure until ATTEN TEST cable calibration is complete.

Note

A tool is available for use in converting between the following: dBm, VPP, Watts, and Divisions (Divisions is used with 1.5T systems only). This tool is located on the Signa Release 8.X Service Methods CD-ROM under the Tools directory, titled: SCOPECAL.xls.

Path:

[START] [Programs] [Windows Explorer] [Mrservice (drive)] [Tools] [SCOPECAL.xls].

There is no associated oscilloscope bandwidth limitation (frequency roll-off) for 1.0Tsystems using a 100 MHz oscilloscope, therefore, if using the SCOPECAL.xls tool the:

- Set the oscilloscope "Volts/div" control knob to 0.5 VDC setting (so that 8 divisions equals 1VP-P).
 - "Volts Peak to Peak value of 1.5T Scope Calibrator waveform" would equal 1.
 - "# of minor divisions the waveform covers on oscilloscope would equal 40.
4. At operator workspace, select the scan desktop ICON in the desktop control panel, if you have not already done so.
 5. At the operator workspace, prepare the system for a Head Power Monitor scan using the "Service Protocols" procedure below.

2-3-3 Head Checks (continued)

TABLE 2-4
SCAN PRESCRIPTION - HEAD PM CHECKS

<p>Note: This is the alternate proprietary procedure available for GE use, and to sites with a valid Advanced Service Package Limited License.</p> <ol style="list-style-type: none"> 1. [New Pt] Id: geservice <ENTER> Name: pmc Weight (Lb.): 300 Set Patient Protocols to Service. 2. At front enclosure: Landmark in the Head area—remove any coils. press LANDMARK. press MOVE TO SCAN. 3. At Patient Protocols – select other. 4. In the protocol field, type o.23.1<ENTER> (o=Other, 23.1 =series) to load the head protocol OR select [o.23] [Series 1] [Accept]. [OK] (if required). 5. [Save Series]. 6. [Prepare to Scan]. 7. [Research Operations]. [Setup Params]. Set TG to 50. [Done]. [Research Operations]. [Display CVs]. Highlight CV Name and enter the following: CV name: See appropriate Table <ENTER>. [Accept]. 8. [Research Operations] [Download]. 9. [Prepare to Scan]. 10. Select [Manual Prescan].
--

6. Perform head checks per Table 2-5 (1.5T) or Table 2-6 (1.0T).

Note

Selecting Setpoint Values - All setpoint values are selected by modifying control variables. Instructions are provided in the Scan Conditions column in Table 2-5 (1.5 T).

Note

Wattmeter Reading - Wattmeter reading must be multiplied by cable attenuation factor of cables between the ERBTEC RF amplifier and the wattmeter.

Note

Oscilloscope Reading - Oscilloscope reading must be multiplied by dummy load cable(s) attenuation factor between the ERBTEC RF amplifier and the oscilloscope.

2-3-3 Head Checks (continued)

TABLE 2-5
HEAD CHECKS (1.5T) LX

Test	Scan Conditions	Adjustments (Note 1)	Verify	Conclusion
HEAD PEAK POWER <i>high</i>	[modify CVs] calmode = 2 trig = 7 aset = 120 [Accept] [Download] [Manual Prescan]	Increase Transmit Gain (TG) until first FAULT LED on, measure Power. Continue increasing TG until other FAULT LED on, measure power.	Power is within specifications: Min: 1318 W or 61.2 dBm Max: 1784 W or 62.5 dBm Nom: 1551 W or 61.9 dBm ☐ Pass ☐ Fail	Set TG to 0, Place MONITOR INTERLOCK (MON INTLK) switch to RESET , then MODE1 , [Done].
HEAD PEAK POWER <i>LOW</i>	[modify CVs] aset = 30 [Accept] [Download] [Manual Prescan]	Increase TG until first FAULT LED on, measure Power. Continue increasing TG until other FAULT LED on, measure Power.	Power is within specifications: Min: 330 W or 55.2 dBm Max: 446 W or 56.5 dBm Nom: 388 W or 55.9 dBm ☐ Pass ☐ Fail	Set TG to 0, Place MON INTLK switch to RESET , then MODE1 , [Done].
HEAD PULSE WIDTH (PW) <i>high</i> (min Limit)	[Modify CVs] calmode = 1 p1 = 4750 aset = 255 pwset = 100 [Accept] [Download] [Manual Prescan]	Increase TG (from 0) until Power measures 200W (53.0 dBm) to 300W (54.8 dBm). (Note 2)	SENSE LEDs (both ON) HEAD LEDs (both ON) FAULT LEDs (both OFF) ☐ Pass ☐ Fail	[Done].
HEAD PW <i>High</i> (Max Limit)	[Modify CVs] p1 = 5250 [Accept] [Download] [Manual Prescan]	Do not change TG.	FAULT LEDs (both ON) ☐ Pass ☐ Fail	[Done], MON INTLK to RESET , then MODE1 .
HEADPW <i>LOW</i> (Min Limit)	[Modify CVs] p1 = 400 pwset = 10 [Accept] [Download] [Manual Prescan]	Do not change TG.	SENSE LEDs (both ON) HEAD LEDs (both ON) FAULT LEDs (both OFF) ☐ Pass ☐ Fail	[Done].
HEAD PW <i>LOW</i> (Max Limit)	[Modify CVs] p1 = 600 [Accept] [Download] [Manual Prescan]	Do not change TG.	FAULT LEDs (both ON) ☐ Pass ☐ Fail	[Done], MON INTLK to RESET , then MODE1 .
HEAD DUTY CYCLE (DC) <i>HIGH</i> CYCLE (DC) (Min Limit)	[Modify CVs] t3 = 33333 TR_SLOP = 0 calmode = 3 p3 = 3900 pwset = 255 dcset = 130 [Accept] [Download] [Manual Prescan]	Do not change TG.	SENSE LEDs (both ON) HEAD LEDs (both ON) FAULT LEDs (both OFF) (Note 3) ☐ Pass ☐ Fail	[Done].
HEAD DC <i>High</i> (Max limit)	[Modify CVs] p3 = 4767 [Accept] [Download] [Manual Prescan]	Do not change TG.	FAULT LEDs (both ON) (Note 3) ☐ Pass ☐ Fail	[Done]. MON INTLK to RESET , then MODE1 .
HEAD DC <i>LOW</i> (Min Limit)	[Modify CVs] p3 = 750 dcset = 25 [Accept] [Download] [Manual Prescan]	Do not change TG.	SENSE LEDs (both ON), HEAD LEDs (both ON), FAULT LEDs (both OFF) (Note 3) ☐ Pass ☐ Fail	[Done].

TABLE 2-5 (CONTINUED)
 HEAD CHECKS (1.5T) LX

Test	Scan Conditions	Adjustments (Note 1)	Verify	Conclusion
HEAD DC LOW (Max Limit)	[Modify CVs] p3 =917 [Accept] [Download] [Manual Prescan]]	Do not change TG.	FAULT LEDs (both ON) (Note 3) ☐ Pass ☐ Fail	[Done], MON INTLK to RESET, then MODE1.
<p>Note: Wattmeter reading must be multiplied by Cable Attenuation factor.</p> <p>Note 2: If necessary, increase TG until both SENSE and both HEAD LEDs come on. No more than 500 Watts (56.99 dBm) should be necessary.</p> <p>Note 3: Allow at least 12 seconds after looping starts before checking status of FAULT LEDs.</p>				

2-3-3 Head Checks (continued)

Note

Selecting Setpoint Values - All setpoint values are selected by modifying control variables. Instructions are provided in the Scan Conditions column in Table 2-6 (1.0 T).

Note

Oscilloscope Reading - Oscilloscope reading must be multiplied by dummy load cable(s) attenuation factor between the ERBTEC RF amplifier and the oscilloscope.

TABLE 2-6
HEAD CHECKS (1.0T) LX

Test	Scan Conditions	Adjustments	Verify	Conclusion
HEAD PEAK POWER <i>high</i>	[Modify CVs] calmode = 2 trig = 7 aset = 50 [Accept] [Download] [Manual Prescan]	Increase Transmit Gain (TG) until first FAULT LED on, measure Power. Continue increasing TG until other FAULT LED on, measure power.	Power is within specifications: Min: 160 W or 52 dBm Max: 240 W or 53.8 dBm Nom: 200 W or 53 dBm ☐ Pass ☐ Fail	Set TG to 0, Place MONITOR INTERLOCK (MON INTLK) switch to RESET , then MODE1 , [Done] .
HEAD PEAK POWER <i>LOW</i>	[Modify CVs] aset = 30 [Accept] [Download] [Manual Prescan]	Increase TG until first FAULT LED on, measure Power. Continue increasing TG until other FAULT LED on, measure Power.	Power is within specifications: Min: 100 W or 50 dBm Max: 136 W or 51.34 dBm Nom: 117 W or 50.7 dBm ☐ Pass ☐ Fail	Set TG to 0, Place MON INTLK switch to RESET , then MODE1 , [Done] .
HEAD PULSE WIDTH (PW) <i>high</i> (min Limit)	[Modify CVs] calmode = 1 p1 = 3912 aset = 255 pwset = 35 [Accept] [Download] [Manual Prescan]	Increase TG (from 0) until Power measures 50W (46.9 dBm) to 70W (48.45 dBm). (Note 1)	SENSE LEDs (both ON) HEAD LEDs (both ON) FAULT LEDs (both OFF) ☐ Pass ☐ Fail	[Done] .
HEAD PW <i>High</i> (Max Limit)	[Modify CVs] p1 = 4324 [Accept] [Download] [Manual Prescan]	Do not change TG.	FAULT LEDs (both ON) ☐ Pass ☐ Fail	[Done] , MON INTLK to RESET , then MODE1 .
HEAD PW <i>LOW</i> (Min Limit)	[Modify CVs] p1 = 1076 pwset = 10 [Accept] [Download] [Manual Prescan]	Do not change TG.	SENSE LEDs (both ON) HEAD LEDs (both ON) FAULT LEDs (both OFF) ☐ Pass ☐ Fail	[Done] .
HEAD PW <i>LOW</i> (Max Limit)	[Modify CVs] p1 = 1276 [Accept] [Download] [Manual Prescan]	Do not change TG.	FAULT LEDs (both ON) ☐ Pass ☐ Fail	[Done] , MON INTLK to RESET , then MODE1 .
HEAD DUTY CYCLE (DC) <i>HIGH</i> CYCLE (DC) (Min Limit)	[Modify CVs] t3 = 33333 TR_SLOP = 0 calmode = 3 p3 = 3900 pwset = 255 dcset = 130 [Accept] [Download] [Manual Prescan]	Do not change TG.	SENSE LEDs (both ON) HEAD LEDs (both ON) FAULT LEDs (both OFF) (Note 3) ☐ Pass ☐ Fail	[Done] .

TABLE 2-6 (CONTINUED)
 HEAD CHECKS (1.0T) LX

Test	Scan Conditions	Adjustments	Verify	Conclusion
HEAD DC <i>High</i> (Max limit)	[Modify CVs] p3 = 4767 [Accept] [Download] [Manual Prescan]	Do not change TG.	FAULT LEDs (both ON) (Note 2) ☐ Pass ☐ Fail	[Done]. MON INTLK to RESET, then MODE1.
HEAD DC <i>LOW</i> (Min Limit)	[Modify CVs] p3 = 750 dcset = 25 [Accept] [Download] [Manual Prescan]	Do not change TG.	SENSE LEDs (both ON) HEAD LEDS (both ON) FAULT LEDs (both OFF) (Note 2) ☐ Pass ☐ Fail	[Done].
HEAD DC <i>LOW</i> (Max Limit)	[Modify CVs] p3 =917 [Accept] [Download] [Manual Prescan]	Do not change TG.	FAULT LEDs (both ON) (Note 2) ☐ Pass ☐ Fail	[Done], MON INTLK to RESET, then MODE1.

Note 1: If necessary, increase TG until both SENSE and both HEAD LEDs come on. No more than 100 Watts (50.0 dBm) should be necessary.

Note 2: Allow at least 12 seconds after looping starts before checking status of FAULT LEDs.

2-3-4 Body Checks

- The following generic Illustration 2-17 has been provided for sites without the RF Power Measurement Kit.

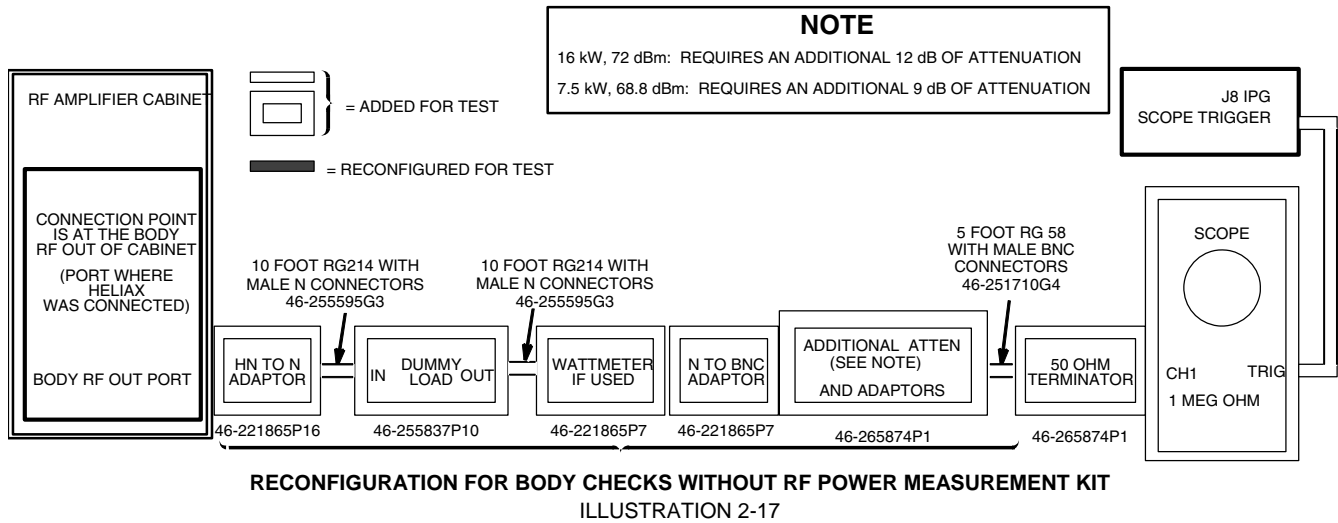

Note

Maximum RF Signal input for any scope is 30 dBm (10 Volts Peak, 20 VPP).

Note

Both the dummy load and the cable that connects the amplifier output to the dummy load input must be calibrated per *DUMMY LOAD AND CABLES CALIBRATION*. See Signa Release 8.X Service Methods CD-ROM. If the cable has not been calibrated, STOP; do not continue with this procedure until cable calibration is complete.

Verify the selectable oscilloscope input termination is 1 Meg ohm when using the RF Power Measurement Kit 50 ohm terminator. Otherwise, the oscilloscope should be 50 ohm termination for all RF measurements.

2-3-4 Body Checks (continued)

2. **For 1.5T systems:** Connect per Illustration 2-17 to Body output (J13 at I/F panel / J2 at Body Directional Coupler) of the RF/PEN cabinet. If using a wattmeter use the proper element. Or use the RF Power Measurement Kit card # 72 (16 kW, 72 dBm). For 1.5T is necessary to use the 1.5T Scope Calibrator card to compensate for scope bandwidth limitations (frequency roll-off), refer to the Appendix A for instructions.

Verify the selectable oscilloscope input termination is 1 Meg ohm when using the RF Power Measurement Kit 50 ohm terminator. Otherwise, the oscilloscope should be 50 ohm termination for all RF measurements.

Note

Calibrate The Amplifier Output To Wattmeter Input Cable - The cable that is used to connect the amplifier output to the wattmeter input must be calibrated per procedure Dummy Load and Cables Calibration. If the cable has not been calibrated, STOP, do not continue with this procedure until ATTEN TEST cable calibration is complete.

Note

A tool is available for use in converting between the following: dBm, VPP, Watts, and Divisions (Divisions is used with 1.5T systems only). This tool is located on the Signa Release 8.X Service Methods CD-ROM under the Tools directory, titled: SCOPECAL.xls.

Path:

[START] [Programs] [Windows Explorer] [Mrservice (drive)] [Tools] [SCOPECAL.xls].

2-3-4 Body Checks (continued)

3. **For 1.0T systems:** Connect per Illustration 2-17 to Body output (J13 at I/F panel / J2 at Body Directional Coupler) of the RF/PEN cabinet. If using a wattmeter use the proper element. Or use the RF Power Measurement Kit card # 68.8 (7.5 kW, 68. dBm).

Note

Calibrate The Amplifier Output To Wattmeter Input Cable - The cable that is used to connect the amplifier output to the wattmeter input must be calibrated per procedure Dummy Load and Cables Calibration. If the cable has not been calibrated, STOP, do not continue with this procedure until ATTEN TEST cable calibration is complete.

Note

A tool is available for use in converting between the following: dBm, VPP, Watts, and Divisions (Divisions is used with 1.5T systems only). This tool is located on the Signa Release 8.X Service Methods CD-ROM under the Tools directory, titled: SCOPECAL.xls.

Path:

[START] [Programs] [Windows Explorer] [Mrservice (drive)] [Tools] [SCOPECAL.xls].

There is no associated oscilloscope bandwidth limitation (frequency roll-off) for 1.0Tsystems using a 100 MHz oscilloscope, therefore, if using the SCOPECAL.xls tool the:

- Set the oscilloscope “Volts/div” control knob to 0.5 VDC setting (so that 8 divisions equals 1VP-P).
 - “Volts Peak to Peak value of 1.5T Scope Calibrator waveform” would equal 1.
 - “# of minor divisions the waveform covers on oscilloscope would equal 40.
4. At operator work space, select the scan icon in the desktop control panel, if you have not already done so.
 5. At the operator work space, prepare the system for a Body Power Monitor scan using the "Service Protocols" procedure below.

2-3-4 Body Checks (continued)

TABLE 2-7
SCAN PRESCRIPTION - BODY PM CHECKS

<p>Note: This is the alternate proprietary procedure available for GE use, and to sites with a valid Advanced Service Package Limited License.</p> <ol style="list-style-type: none"> 1. [New Series] At Patient Protocols – select other. 2. In the protocol field, type o.23.2<ENTER> (o=Other, 23.2 =series) to load the body protocol OR select [o.23] [Series 2] [Accept]. [OK] (if required). 3. [Save Series]. 4. [Prepare to Scan]. 5. [Research Operations]. [Setup Params]. Set TG to 50. [Done]. [Research Operations]. [Display CVs]. Highlight CV Name and enter the following: CV name: dcset <ENTER>, 255 <ENTER> CV name: t3 <ENTER>, 20000 <ENTER>. CV name: See appropriate Table <ENTER> [Accept]. 6. [Research Operations] [Download]. 7. [Prepare to Scan]. 8. Select [Manual Prescan].

6. Perform body checks per Table 2-8 (1.5T) or Table 2-9 (1.0T).

Note

Selecting Setpoint Values - All setpoint values are selected by modifying control variables. Instructions are provided in the Scan Conditions column in Table 2-8 (1.5 T).

Note

Wattmeter Reading - Wattmeter reading must be multiplied by cable attenuation factor of cables between the ERBTEC RF amplifier and the wattmeter.

Note

Oscilloscope Reading - Oscilloscope reading must be multiplied by dummy load cable(s) attenuation factor between the ERBTEC RF amplifier and the oscilloscope.

2-3-4 Body Checks (continued)

TABLE 2-8
BODY CHECKS (1.5T) LX

Test	Scan Conditions	Adjustments (Note 1)	Verify	Conclusion
BODY PEAK POWER <i>high</i>	[Modify CVs] calmode = 2 trig = 7 aset = 120 [Accept] [Download] [Manual Prescan]	Increase Transmit Gain (TG) until first FAULT LED on, measure Power. Continue increasing TG until other FAULT LED on, measure power.	Power is within specifications: Min: 8793.9 W or 69.44 dBm Max: 11897.7 W or 70.75 dBm Nom: 10345.8 W or 70.15 dBm ☐ Pass ☐ Fail	Set TG to 0, Place MONITOR INTERLOCK (MON INTLK) switch to RESET , then MODE1 , [Done] .
BODY PEAK POWER <i>LOW</i>	[Modify CVs] aset = 30 [Accept] [Download] [Manual Prescan]	Increase TG until first FAULT LED on, measure Power. Continue increasing TG until other FAULT LED on, measure Power.	Power is within specifications: Min: 2198.5 W or 63.42 dBm Max: 2974.5 W or 64.73 dBm Nom: 2586.5 W or 64.13 dBm ☐ Pass ☐ Fail	Set TG to 0, Place MON INTLK switch to RESET , then MODE1 , [Done] .
BODY PULSE WIDTH (PW) <i>high</i> (min Limit)	[Modify CVs] calmode = 1 p1 = 4750 aset = 255 pwset = 100 [Accept] [Download] [Manual Prescan]	Increase TG (from 0) until Power measures 2 kW (63.01 dBm) to 3 kW (64.77 dBm). (Note 2)	SENSE LEDs (both ON) BODY LEDs (both ON) FAULT LEDs (both OFF) ☐ Pass ☐ Fail	[Done] .
BODY PW <i>High</i> (Max Limit)	[Modify CVs] p1 = 5250 [Accept] [Download] [Manual Prescan]	Do not change TG.	FAULT LEDs (both ON) ☐ Pass ☐ Fail	[Done] , MON INTLK to RESET , then MODE1 .
BODY PW <i>LOW</i> (Min Limit)	[Modify CVs] p1 = 400 pwset = 10 [Accept] [Download] [Manual Prescan]	Do not change TG.	SENSE LEDs (both ON) BODY LEDs (both ON) FAULT LEDs (both OFF) ☐ Pass ☐ Fail	[Done] .
BODY PW <i>LOW</i> (Max Limit)	[Modify CVs] p1 = 600 [Accept] [Download] [Manual Prescan]	Do not change TG.	FAULT LEDs (both ON) ☐ Pass ☐ Fail	[Done] , MON INTLK to RESET , then MODE1 .
BODY DUTY CYCLE (DC) HIGH CYCLE (DC) (Min Limit)	[Modify CVs] t3 = 33333 TR_SLOP = 0 calmode = 3 p3 = 3900 pwset = 255 dcset = 130 [Accept] [Download] [Manual Prescan]	Do not change TG.	SENSE LEDs (both ON) BODY LEDs (both ON) FAULT LEDs (both OFF) (Note 3) ☐ Pass ☐ Fail	[Done] .
BODY DC <i>High</i> (Max limit)	[Modify CVs] p3 = 4767 [Accept] [Download] [Manual Prescan]	Do not change TG.	FAULT LEDs (both ON) (Note 3) ☐ Pass ☐ Fail	[Done] . MON INTLK to RESET , then MODE1 .
BODY DC <i>LOW</i> (Min Limit)	[Modify CVs] p3 = 750 dcset = 25 [Accept] [Download] [Manual Prescan]	Do not change TG.	SENSE LEDs (both ON) BODY LEDs (both ON) FAULT LEDs (both OFF) (Note 3) ☐ Pass ☐ Fail	[Done] .

2-3-4 Body Checks (continued)

TABLE 2-8 (CONTINUED)
BODY CHECKS (1.5T) LX

Test	Scan Conditions	Adjustments (Note 1)	Verify	Conclusion
BODY DC LOW (Max Limit)	[Modify CVs] p3 =917 [Accept] [Download] [Manual Prescan]	Do not change TG.	FAULT LEDs (both ON) (Note 2) □ Pass □ Fail	[Done], MON INTLK to RESET, then MODE1.
<p>Note 1: Wattmeter reading must be multiplied by Cable Attenuation factor. Note 2: If necessary, increase TG until both SENSE and both BODY LEDs come on. No more than 5 kW (66.99 dBm) should be necessary. Note 3: Allow at least 12 seconds after looping starts before checking status of FAULT LEDs.</p>				

2-3-4 Body Checks (continued)

Note

Selecting Setpoint Values - All setpoint values are selected by modifying control variables. Instructions are provided in the Scan Conditions column in Table 2-9 (1.0 T).

Note

Oscilloscope Reading - Oscilloscope reading must be multiplied by dummy load cable(s) attenuation factor between the ERBTEC RF amplifier and the oscilloscope.

2-3-4 Body Checks (continued)

TABLE 2-9
BODY CHECKS (1.0T) LX

Test	Scan Conditions	Adjustments (Note 1)	Verify	Conclusion
BODY PEAK POWER <i>high</i>	[Modify CVs] calmode = 2 trig = 7 aset = 110 [Accept] [Download] [Manual Prescan]	Increase Transmit Gain (TG) until first FAULT LED on, measure Power. Continue increasing TG until other FAULT LED on, measure power.	Power is within specifications: Min: 4100 W or 66.127 dBm Max: 4500 W or 66.53 dBm Nom: 4300 W or 66.33 dBm ☐ Pass ☐ Fail	Set TG to 0, Place MONITOR INTERLOCK (MON INTLK) switch to RESET , then MODE1 , [Done] .
BODY PEAK POWER <i>LOW</i>	[Modify CVs] aset = 30 [Accept] [Download] [Manual Prescan]	Increase TG until first FAULT LED on, measure Power. Continue increasing TG until other FAULT LED on, measure Power.	Power is within specifications: Min: 1100 W or 60.41 dBm Max: 1300 W or 61.14 dBm Nom: 1200 W or 60.79 dBm ☐ Pass ☐ Fail	Set TG to 0, Place MON INTLK switch to RESET , then MODE1 , [Done] .
BODY PULSE WIDTH (PW) <i>high</i> (min Limit)	[Modify CVs] calmode = 1 p1 = 3912 aset = 255 pwset = 35 [Accept] [Download] [Manual Prescan]	Increase TG (from 0) until Power measures 500 W (56.99 dBm) to 700 W (58.45 dBm). (Note 2)	SENSE LEDs (both ON) BODY LEDs (both ON) FAULT LEDs (both OFF) ☐ Pass ☐ Fail	[Done] .
BODY PW <i>High</i> (Max Limit)	[Modify CVs] p1 = 4324 [Accept] [Download] [Manual Prescan]	Do not change TG.	FAULT LEDs (both ON) ☐ Pass ☐ Fail	[Done] , MON INTLK to RESET , then MODE1 .
BODY PW <i>LOW</i> (Min Limit)	[Modify CVs] p1 = 1076 pwset = 10 [Accept] [Manual Prescan]	Do not change TG.	SENSE LEDs (both ON), BODY LEDs (both ON), FAULT LEDs (both OFF), ☐ Pass ☐ Fail	[Done] .
BODY PW <i>LOW</i> (Max Limit)	[Modify CVs] p1 = 1276 [Accept] [Download] [Manual Prescan]	Do not change TG.	FAULT LEDs (both ON) ☐ Pass ☐ Fail	[Done] , MON INTLK to RESET , then MODE1 .
BODY DUTY CYCLE (DC) <i>HIGH</i> CYCLE (DC) (Min Limit)	[Modify CVs] t3 = 33333 TR_SLOP = 0 calmode = 3 p3 = 3900 pwset = 255 dcset = 130 [Accept] [Download] [Manual Prescan]	Do not change TG.	SENSE LEDs (both ON) BODY LEDs (both ON) FAULT LEDs (both OFF) (Note 2) ☐ Pass ☐ Fail	[Done] .
BODY DC <i>High</i> (Max limit)	[Modify CVs] p3 = 4767 [Accept] [Download] [Manual Prescan]	Do not change TG.	FAULT LEDs (both ON) (Note 2) ☐ Pass ☐ Fail	[Done] . MON INTLK to RESET , then MODE1 .
BODY DC <i>LOW</i> (Min Limit)	[Modify CVs] p3 = 750 dcset = 25 [Accept] [Download] [Manual Prescan]	Do not change TG.	SENSE LEDs (both ON) BODY LEDs (both ON) FAULT LEDs (both OFF) (Note 2) ☐ Pass ☐ Fail	[Done] .

2-3-4 Body Checks (continued)

TABLE 2-9 (CONTINUED)
BODY CHECKS (1.0T) LX

Test	Scan Conditions	Adjustments (Note 1)	Verify	Conclusion
BODY DC LOW (Max Limit)	[Modify CVs] p3 =917 [Accept] [Download] [Manual Prescan]	Do not change TG.	FAULT LEDs (both ON) (Note 2) □ Pass □ Fail	[Done], MON INTLK to RESET, then MODE1.
<p>Note 1: If necessary, increase TG until both SENSE and both BODY LEDs come on. No more than 1 kW (60 dBm) should be necessary.</p> <p>Note 2: Allow at least 12 seconds after looping starts before checking status of FAULT LEDs.</p>				

2-3-5 Amplifier Shutdown Verification

Tests in this section verify that each power monitor is capable of shutting down the RF Amplifier independently of the other, and further verify both the logic and relay shutdowns for each channel. Setpoints are not checked in this section — this test is forcing a shutdown.

1. It is assumed that the Body output is still connected as in Body Checks section, and that the monitor interlock switch is in MODE 1 position.
2. Place jumpers **JP2 & JP6** on the Communications Manager/Power Monitor Board in the **normal** position, (A). See Illustration 2-18.

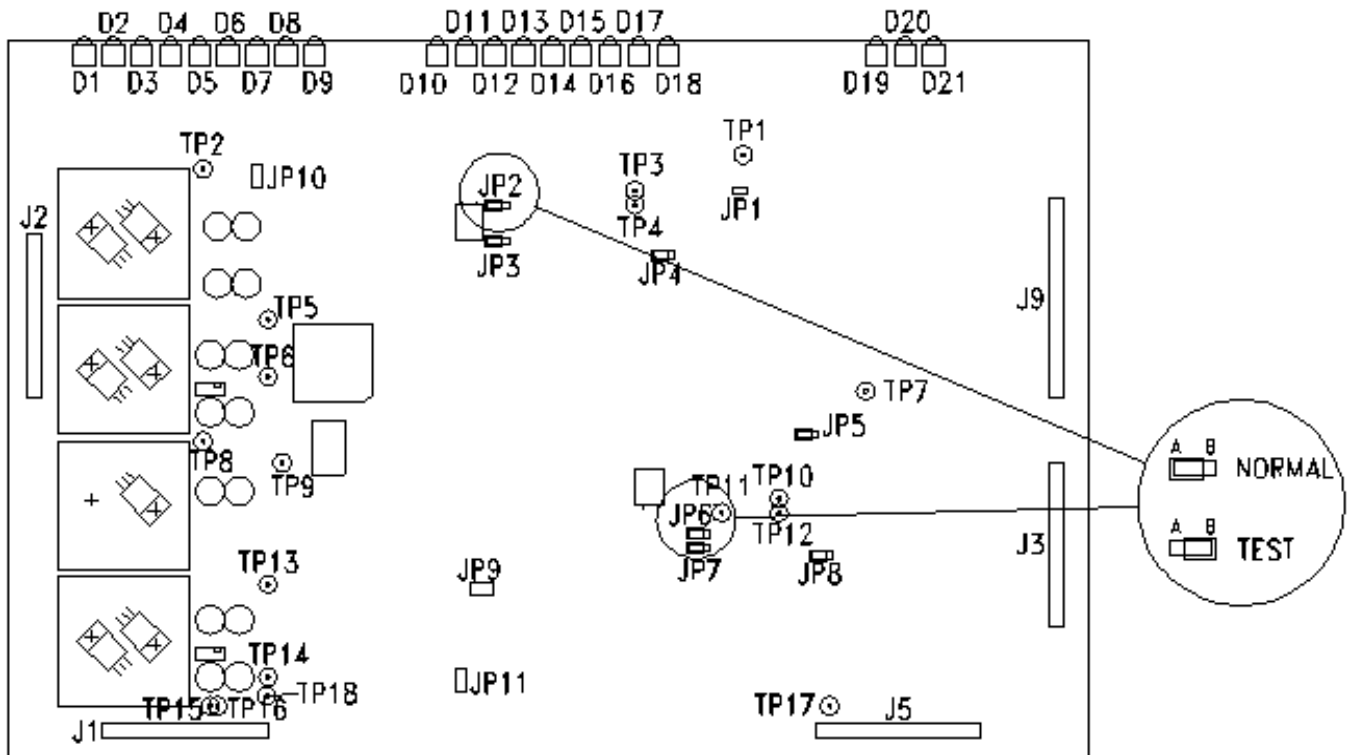

COMMUNICATION MANAGER/POWER MONITOR BOARD JUMPER SETUP
 ILLUSTRATION 2-18

Note

Amplifier Tripped While Moving JP2 - If the amplifier is tripped while moving JP2, IPER (In Place Error Recovery) should reset it about three minutes after the fault condition is cleared. If problems are encountered with the amplifier operation after such a trip, rebooting Signa may be required to restore proper operation.

3. Verify that the Power On and Ready LEDs are illuminated for both power monitors. This confirms that JP2 & JP6 are in the normal position.
4. Disable power monitor B by removing JP9 on the Communications Manager/Power Monitor board.

2-3-5 Amplifier Shutdown Verification (continued)

5. At operator workspace, select the scan desktop icon in the desktop control panel, if you have not already done so.
6. At the operator workspace, prepare the system for a Amp Shutdown Verification scan using the "Service Protocols" procedure, refer to Table 2-10.

TABLE 2-10
SCAN PRESCRIPTION - HIGH VOLTAGE RELAY SHUTDOWN — BODY MODE

Note: This is the alternate proprietary procedure available for GE use, and to sites with a valid Advanced Service Package Limited License.

- A. **[New Series]**
 At Patient Protocols – select **other**.
- B. In the protocol field, type **o.23.3<ENTER>** (o=Other, 23.3 =series) to load the body protocol
OR select **[o.23] [Series 3] [Accept]**.
[OK] (if required).
- C. **[Save Series]**
- D. **[Prepare to Scan]**.
- E. **[Research Operations]**.
[Setup Params]. Set **TG** to **0**. **[Done]**.
- F. **[Research Operations]**.
[Display CVs]. Highlight CV Name and enter the following:
 CV name: **trig <ENTER>, 1 <ENTER>**
 CV name: **aset <ENTER>, 120 <ENTER>**
 CV name: **calmode <ENTER>, 2 <ENTER>**
 CV name: **pwset <ENTER>, 255 <ENTER>**
 CV name: **dcset <ENTER>, 255 <ENTER>**
 CV name: **p1 <ENTER>, 3100 <ENTER>**
 CV name: **p3 <ENTER>, 2400 <ENTER>**
- F. **[Research Operations] [Download]**.
- G. **[Prepare to Scan]**.
- H. Select **[Manual Prescan]**.

2-3-5 Amplifier Shutdown Verification

7. Increase transmit gain (TG) until wattmeter reads 0.5 to 1 kW. The Sense and Body LEDs should be on for power monitor A only. If other indication is observed, verify that all power monitor related sense cables are properly connected, not swapped.
8. Continue increasing TG until monitor A Fault LED lights. Quickly verify the following:
 - Fault LED on for monitor A (resets automatically after two seconds).
 - RF amplifier is shutdown and displaying fault code 84 or 85 (IPER resets the amplifier 10 to 15 seconds after the power monitor fault clears, i.e., a few seconds after the Fault LED goes off on the amplifier). Software Message Log - Software will log an 84 or 85 fault in the message log.
 - Verify oscilloscope or Wattmeter (press FWD PEP then MAX) reads zero RF power.

Note

IPER Resets The RF Amplifier - Do not perform any operations on the screen or keyboard while IPER is resetting the RF amplifier.

9. While waiting for the RF amplifier to recover, move jumper JP8 from the A position to the B position.
10. After IPER has reset the RF amplifier, first decrease TG by 50 counts (5 dB), then press START SCAN on operator work space to initiate looping.
11. Increase TG until monitor A Fault LED illuminates. Quickly verify the following:
 - RF amplifier is shutdown and displaying fault code 84 or 85 (IPER resets the amplifier 10 to 15 seconds after the power monitor fault clears, i.e., a few seconds after the Fault LED goes off on the amplifier). Software Message Log - Software will log an 84 or 85 fault in the message log.
 - Verify oscilloscope or Wattmeter (press FWD PEP then MAX) reads zero RF power.

Note

IPER Resets The RF Amplifier - Do not perform any operations on the screen or keyboard while IPER is resetting the RF amplifier.

12. While waiting for the amplifier to recover:
 - a. Move jumper JP8 from the B position to the A position.
 - b. Reconnect power monitor B by replacing JP9 on the Communications Manager/Power Monitor Board.
 - c. Disconnect power monitor A by removing JP1 on the Communications Manager/Power Monitor Board.
13. After IPER has reset the RF amplifier, first decrease TG by 50 counts (5 dB), then press START SCAN on the operator work station to initiate looping.

2-3-5 Amplifier Shutdown Verification (continued)

14. Increase TG until monitor B Fault LED illuminates. Quickly verify the following:

- Fault LED on monitor B control board (resets automatically after six seconds).
- RF amplifier is shutdown and displaying fault code 84 or 85 (IPER resets the amplifier 10 to 15 seconds after the power monitor fault clears, i.e., as soon as the Fault LED goes off on the amplifier). Software Message Log - Software will log an 84 or 85 fault in the message log.
- Verify oscilloscope or Wattmeter (press FWD PEP then MAX) reads zero RF power.

Note

IPER Resets The RF Amplifier - Do not perform any operations on the screen or keyboard while IPER is resetting the RF amplifier.

15. After IPER has reset the RF amplifier, select **[Back Up]**.

16. **[Set Up Parameters]** set TG to 0 (zero).

17. **[Cancel]** or **[End]** current study.

- a. Re-connect power monitor A by installing JP1 on the Communications Manager/Power Monitor Board.

2-3-6 Declaration Form Preparation

1. Prepare *Direction 2147006, Signa Power Monitor Functional Test Declaration*. Refer to Data Sheet for Power Monitor Test Declaration Form.
2. File completed declaration form per current Company Policy.

2-3-7 System Restoration

1. Replace JP9 and JP1 on the Communications Manager/Power Monitor Board. See locations in Illustration 2-18.
2. Return the rocker switch on the front panel of the RFSC Module to OFF; no red will be visible.
3. Disconnect dummy load, wattmeter, and test equipment from rear of RF cabinet.
4. Reconnect head and body heliax cables to rear of RF cabinet.
5. Ensure that JP2 and JP6 are in the Normal position, (A), on the Communications Manager/Power Monitor Board. See Illustration 2-18.
6. Ensure that Power On and Ready LEDs are illuminated for both power monitors.
7. Verify that jumper JP8 is in position A.
8. Close the top lid of the RF system controller power supply module. Properly screw RFSC Module cover in place.
9. Remove the variable attenuator from the J103 / J105 RFSC Module RF path. Reconnect BNC cables to RFIN, MR1A15J105 and EFB RFOUT, MR1A15J103. See Illustration 2-12.
10. Perform one satisfactory head scan.
11. Ensure that Sense and Head LEDs for both power monitors are on during head scan.
12. Perform one satisfactory body scan.
13. Ensure that Sense and Head LEDs for both power monitors are on during body scan.
14. Properly screw RFSC Module to RF/Pen rails.
15. Remove key from the monitor interlock switch, and replace the front door on the RF/PEN cabinet.
16. Perform power monitor functional check Data Sheet Direction 2147006, "Declaration" form prepared and filed according to current Company Policy.

2-4 PERFORM POWER MONITOR FUNCTIONAL CHECKS—RF/PEN II CABINET

Use this procedure to ensure that the power monitors are fully functional, including redundant trip capability. The tests described use a special pulse sequence data base (PSD) to provide excitation for the RF amplifier. The PSD allows the service engineer to selectively force peak power, pulse width, and duty cycle beyond allowable limits. Select setpoints for testing by modifying control variables that override the values normally calculated and downloaded by the PSD.

After checking the setpoints, the actual shutdown of the amplifier is verified three times: once for monitor A, once for monitor B, and once for the HV relay shutdown.

2-4-1 TOOLS AND INSTRUMENTS REQUIRED

See Table 2-11.

TABLE 2-11
 TOOLS AND INSTRUMENTS REQUIRED (1.0T AND 1.5T)

ITEM	DESCRIPTION	PART NUMBER	QTY.
1.	RF Wattmeter - Bird ThruLine Model 4391	46-255837P1	1
2.	10000-Watt interchangeable element Bird No. 10000B	46-255837p101	1
3.	500-Watt interchangeable element Bird No. 5000B	46-255837P105	1
4.	RF Test Cables Kit	46-255816G1	1
5.	Fifty-ohm, 200 watt, 30 dB attenuator - Bird Model 8322	46-255837P10	1
—OR—			
6.	RF Power Measurement Kit	46-317724G1 or G2	1
7.	100MHz Scope - Tektronix 468 or equivalent	46-183029P61 or P64	1

2-4-2 Hardware Preparation

Perform the prerequisite calibration procedures in the sequence listed in Table 2-12.

TABLE 2-12
POWER MONITOR CALIBRATION PROCEDURE

STEP	TAB	PROCEDURE	WHEN REQUIRED
1a or	RF	<i>Dummy Load & Cables Calibration</i>	If dummy load and cables have not been calibrated
1b	RF	<i>RF Power Measurement Calibration</i>	If oscilloscope has not been calibrated. (RF Power Measurement Kit)
2	RF	<i>APM Calibration</i>	Initial installation or if RF amp has been repaired
3	RF	<i>SAR Configuration File</i>	Initial installation or if site SAR limits change
4	RF	<i>Electrical Isocenter CAL (New DQA)</i>	Initial installation or if step 1 or 2 are redone



Possible equipment damage. Ensure that the RF amplifier has a dummy load connected to its output before initiating tests. If not, amplifier components could be permanently damaged.

Software Status

Signa software must be running, and the system must be capable of normal imaging.

2-4-2 Hardware Preparation (continued)

1. Remove the front door from the cabinet.
2. On the front panel of the SSM, place the two monitor switches in the Normal position, and place the three DRV FLT switches in the disable faults position (DIS). See Illustration 2-19

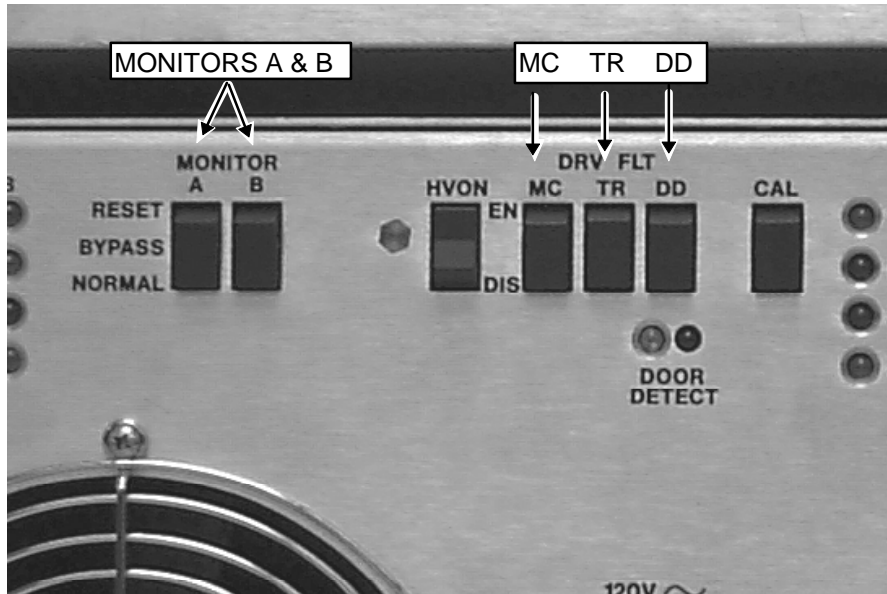

FRONT PANEL SWITCHES DISABLED
ILLUSTRATION 2-19

2-4-2 Hardware Preparation (continued)

- 3. Bypass EFB with a BNC Bullet inline, between RF IN (J3) and EFB RF OUT (J103) on the rear panel of the system support module (SSM). See Illustration 2-20.

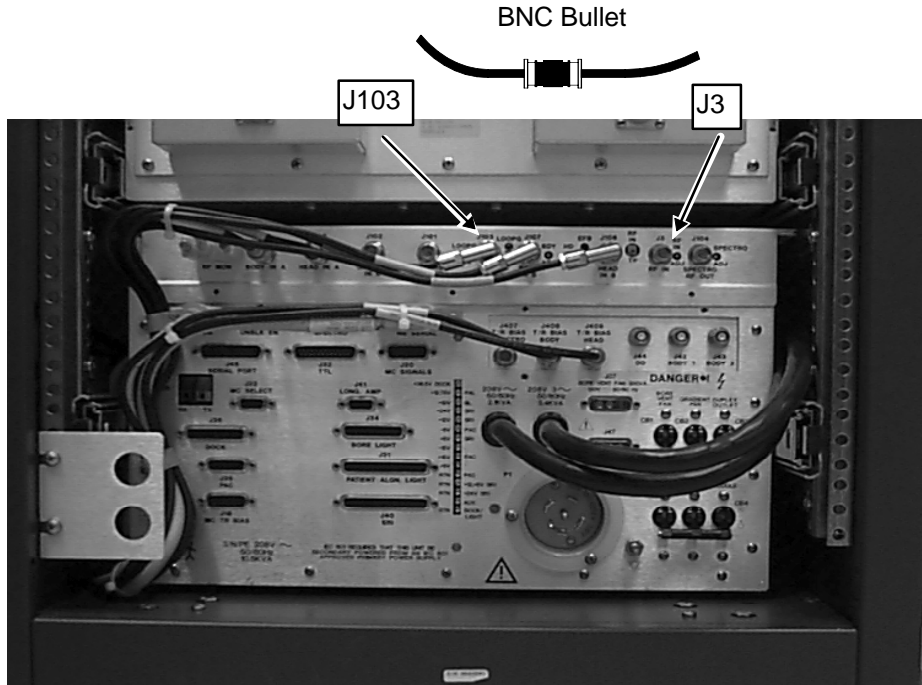

BYPASSING EFB
ILLUSTRATION 2-20

2-4-2 Hardware Preparation (continued)

- 1.5T: Connect the dummy load and wattmeter (10kW element) to the body output of the cabinet. See Illustration 2-21 or Illustration 2-22 (RF Power Kit).

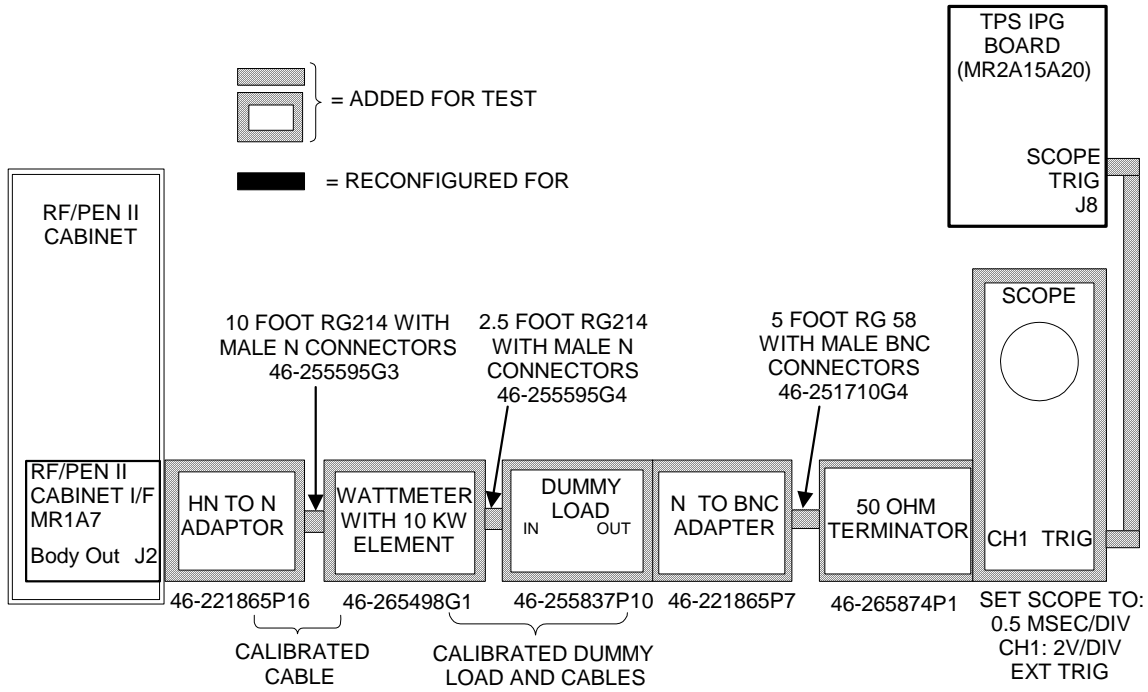

RECONFIGURATION FOR BODY CHECKS (1.5T)
 ILLUSTRATION 2-21

2-4-2 Hardware Preparation (continued)

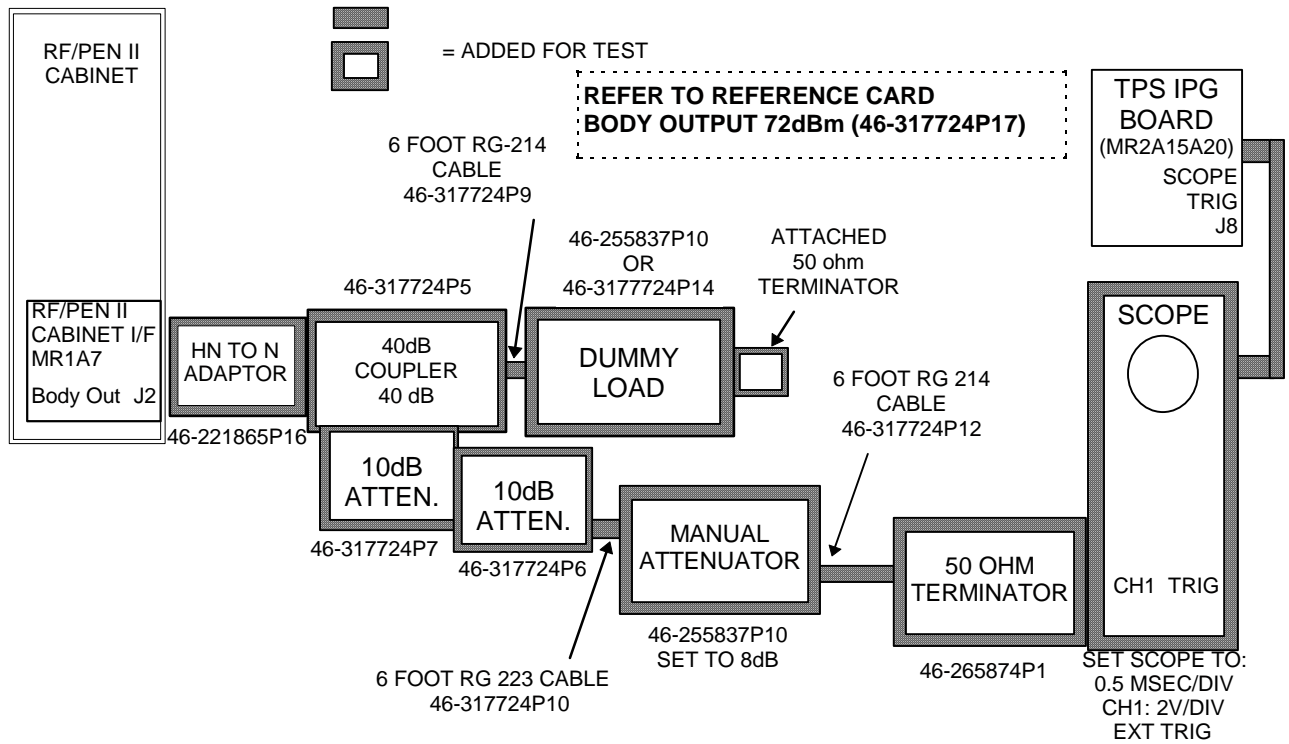

RECONFIGURATION FOR BODY CHECKS USING RF POWER MEASUREMENT KIT (1.5T)
ILLUSTRATION 2-22

5. **1.0T:** Connect the dummy load to the body output of the cabinet. See Illustration 2-23 or Illustration 2-24 (RF Power Kit).

Note

Calibrate the amplifier output to wattmeter input cable

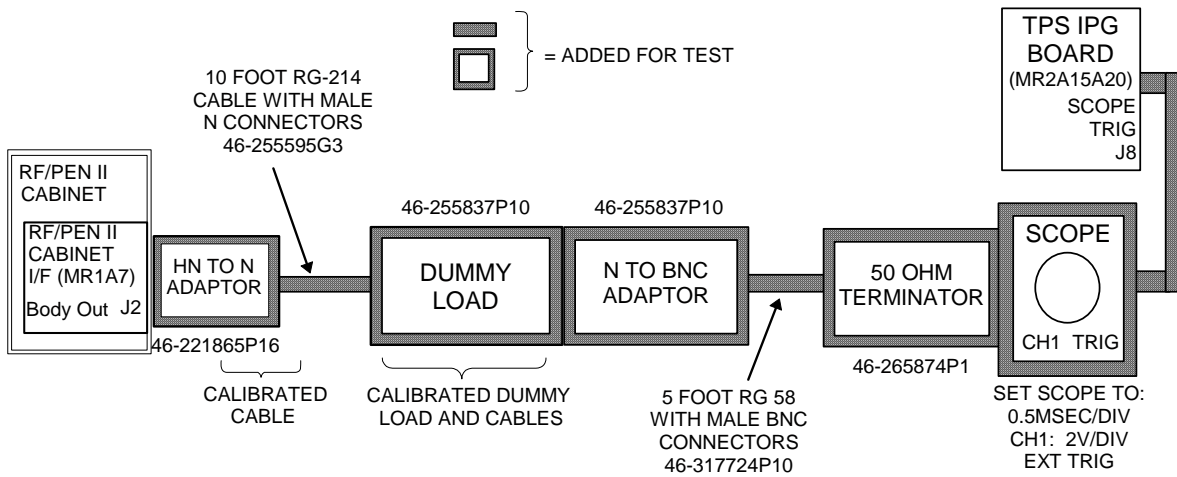

RECONFIGURATION FOR BODY CHECKS (1.0T)
ILLUSTRATION 2-23

2-4-2 Hardware Preparation (continued)

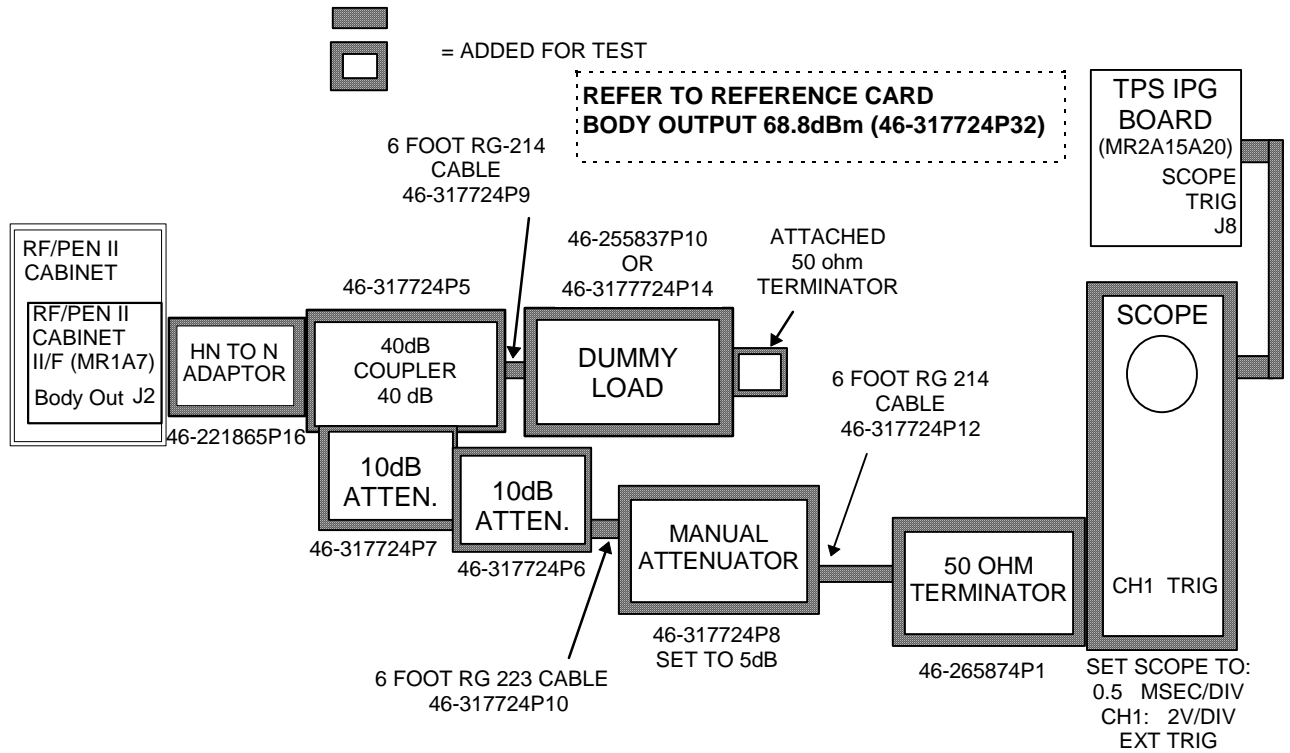

RECONFIGURATION FOR BODY CHECKS USING RF POWER MEASUREMENT KIT (1.0T)
 ILLUSTRATION 2-24

2-4-2 Hardware Preparation (continued)

6. Disable both power monitors by placing the two monitor switches on the front panel of the SSM in the Bypass position.
7. Remove the test window from the Test Switches and Test LEDs on the front of the SSM. See Illustration 2-25.

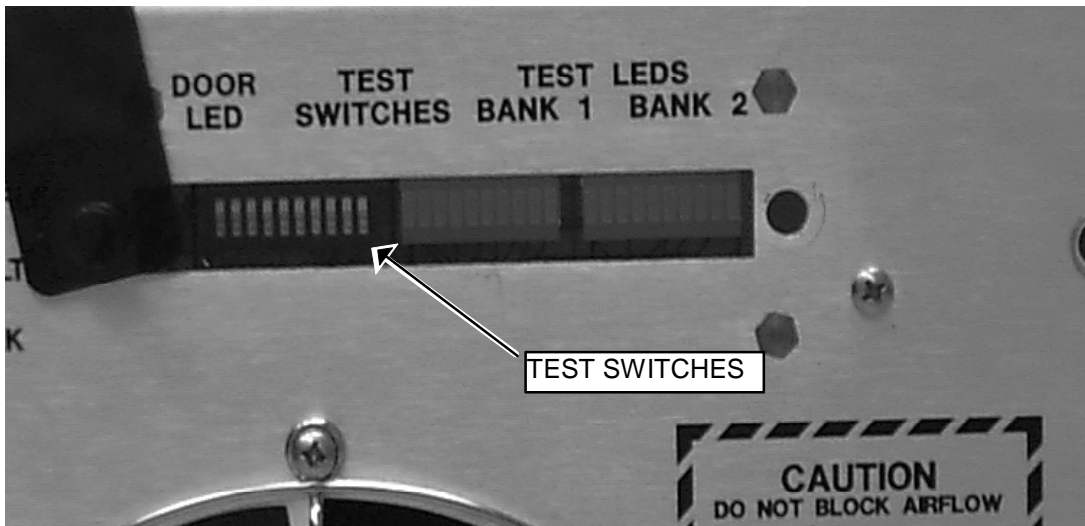

INSIDE THE TEST WINDOW
ILLUSTRATION 2-25

2-4-2 Hardware Preparation (continued)

8. Place the first four switches in the order and positions shown in Table 2-13 or for the alternate proprietary procedure, see Table 2-14.

TABLE 2-13
 SWITCH POSITIONS

SWITCH NUMBER	POSITION
2	UP
3	DOWN
4	UP
1	UP

TABLE 2-14
 ALTERNATE PROPRIETARY PROCEDURE USING LAPTOP

Connect the laptop serial port to J46 on the rear of the SSM, using cable part number 2124497-46 (supplied with every cabinet). See Illustration 2-26. If this cable is not available, use a suitable null modem and 9-25 pin cable adapter. See Illustration 2-26.

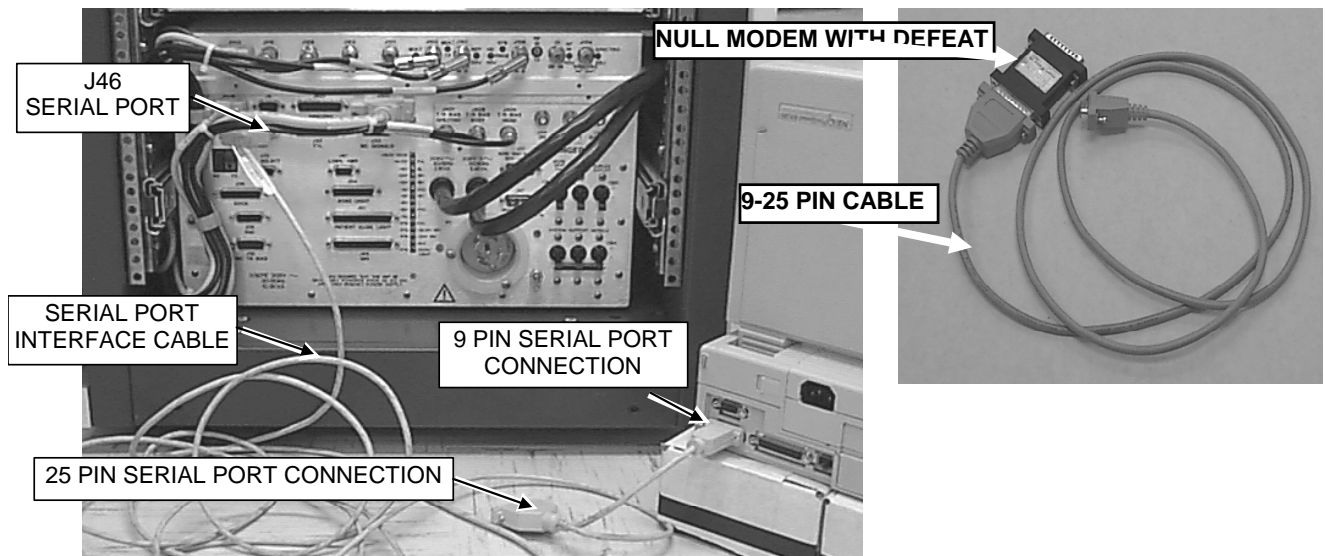

LAPTOP CONNECTED TO SSM
 ILLUSTRATION 2-26

2-4-3 Body Checks

Tests in this section allow the service engineer to selectively force body mode peak power, pulse width, and duty cycle beyond allowable limits.

Note

If using the Alternate Proprietary Procedure Using the Laptop, see Table 2-15. Otherwise move to step 2.

TABLE 2-15
 ALTERNATE PROPRIETARY PROCEDURE — LAPTOP SOFTWARE

1. Start the software diagnostic program MONS.EXE on the laptop.

Note

The MONS.exe program if not loaded on the service laptop can be loaded from the MR Service CD-ROM 2187583-2. Insert your latest 2187583-2 CD into the CD ROM drive. Under Windows 95 use the cursor to select "**Start**" and then "**Run**". In the edit box type the following.

d:\mrtools\win95.exe

Follow the instructions of the setup program to install the Service Tools. The MONS.EXE must be run from DOS. In Windows95 perform the following steps:

- 1) **[Start], [Shut Down...], Restart the computer in MS-DOS mode?, [Yes]**
- 2) At the C:\Windows> prompt, type **cd..<ENTER>**
- 3) Type **cd Cclass<ENTER>**
- 4) At the C:\CCLASS> prompt, type **cd erbttec<ENTER>**
- 5) At the C:\CCLASS\ERBTEC> prompt type **mons.exe<ENTER>**

Select **N** for Next Screen, then select **T** for Test Mode Screen. This screen latches a fault to the laptop screen when it occurs, and the amplifier will not shut down. The main screen will display information needed for the tests.

2-4-3 Body Checks (continued)

1. At the operator workspace, prepare the system for a Body Power Monitor scan using the "Service Protocols" procedure; refer to Table 2-16.

TABLE 2-16
SCAN PRESCRIPTION - BODY PM CHECKS

Note: This is the alternate proprietary procedure available for GE use, and to sites with a valid Advanced Service Package Limited License.

- A. **[New Pt]**
 Id: **geservice <ENTER>**
 Name: **pmc**
 Weight (Lb.): **300**
 Set Patient Protocols to **Service**.
- B. **At front enclosure:**
 Landmark in the Head area—remove any coils.
 press **LANDMARK**.
 press **MOVE TO SCAN**.
- C. **[New Series]**
 At Patient Protocols – select **other**.
- D. In the protocol field, type **o.23.2<ENTER>** (o=Other, 23.2 =series) to load the body protocol
OR select **[o.23] [Series 2] [Accept]**.
[OK] (if required).
- E. **[Save Series]**
- F. **[Prepare to Scan]**.
- G. **[Research Operations]**.
[Setup Params]. Set Plot to **OFF**. Set **TG** to **50**. **[Done]**.
- H. **[Research Operations]**.
[Display CVs]. Highlight CV Name and enter the following:
 CV name: **dcset <ENTER>, 255 <ENTER>**
 CV name: **t3 <ENTER>, 20000 <ENTER>**
 CV name: **see appropriate Table<ENTER>, see appropriate Table <ENTER>**
[Accept].
- I. **[Research Operations] [Download]**.
- J. **[Prepare to Scan]**.
- K. Select **[Manual Prescan]**.

3. Perform body checks as per Table 2-17 (1.5T) or Table 2-18 (1.0T).

Note

All setpoint values are selected by modifying control variables. Instructions are provided in the Scan Conditions column in Table 2-17 (1.5T) or Table 2-18 (1.0T).

Note

Wattmeter reading must be multiplied by cable attenuation factor of cables between the RF amplifier and the wattmeter.

Note

Oscilloscope reading must be multiplied by dummy load and cable(s) attenuation factor between the RF amplifier and the oscilloscope.

2-4-3 Body Checks (continued)

TABLE 2-17
BODY CHECKS (1.5T)

TEST	SCAN CONDITIONS	ADJUSTMENTS (Note 1)	VERIFY	CONCLUSION
BODY PEAK POWER HIGH	[Display CVs] calmode = 2 trig = 7 aset = 120 [Accept] [Download] [Manual Prescan].	Increase Transmit Gain (TG) until laptop or SSM LED indicates fault occurred on one of the monitors; measure Power. Continue increasing TG until laptop or SSM LED indicates other monitor has faulted; measure Power.	Power is within specifications Min: 8793.9W or 69.4dBm Max: 11897.7W or 70.75dBm Nom: 10345.8W or 70.1dBm <input type="checkbox"/> Pass <input type="checkbox"/> Fail	Set TG to 0 [Done]. Place both monitor switches to RESET, then BYPASS. On laptop, press 'C' to continue.
BODY PEAK POWER LOW	[Display CVs] aset = 30 [Accept] [Download] [Manual Prescan].	Increase TG until laptop or SSM LED indicates fault occurred on one of the monitors; measure Power. Continue increasing TG until laptop or SSM LED indicates other monitor has faulted; measure Power.	Power is within specifications Min: 2198.5W or 63.4dBm Max: 2974.5W or 64.7dBm Nom: 2586.5W or 64.1dBm <input type="checkbox"/> Pass <input type="checkbox"/> Fail	Set TG to 0 [Done]. Place both monitor switches to RESET, then BYPASS. On laptop, press 'C' to continue.
BODY PULSE WIDTH(PW) HIGH (Min Limit)	[Display CVs]: calmode = 1 p1 = 4750 aset = 255 pwset = 100 [Accept] [Download] [Manual Prescan].	Increase TG (from 0) until Power measures 2 - 3kW. (Note 2)	SENSE LEDs (both blinking), <input type="checkbox"/> Pass <input type="checkbox"/> Fail	[Done].
BODY PW HIGH (Max Limit)	[Display CVs]: p1 = 5250 [Accept] [Download] [Manual Prescan].	Do not change TG.	Laptop or SSM LED indicates monitor faulted. <input type="checkbox"/> Pass <input type="checkbox"/> Fail	[Done] Place both monitor switches to RESET, then BYPASS. On laptop, press 'C' to continue.
BODY PW LOW (Min Limit)	[Display CVs]: p1 = 400 pwset=10 [Accept] [Download] [Manual Prescan].	Do not change TG.	SENSE LEDs (both blinking) <input type="checkbox"/> Pass <input type="checkbox"/> Fail	[Done].
BODY PW LOW (Max Limit)	[Display CVs]: p1 = 600 [Accept] [Download] [Manual Prescan].	Do not change TG.	Laptop or SSM LED indicates monitor faulted. <input type="checkbox"/> Pass <input type="checkbox"/> Fail	[Done], Place both monitor switches to RESET, then BYPASS. On laptop, press 'C' to continue.
BODY DUTY CYCLE (DC) HIGH (Min Limit)	[Display CVs]: calmode = 3 t3=33333 TR_SLOP=0 p3 = 3900 pwset = 255 dcset = 130 [Accept] [Download] [Manual Prescan].	Do not change TG.	SENSE LEDs (both blinking), <input type="checkbox"/> Pass <input type="checkbox"/> Fail	[Done].

2-4-3 Body Checks (continued)

TABLE 2-17 (continued)
BODY CHECKS (1.5T)

TEST	SCAN CONDITIONS	ADJUSTMENTS (Note 1)	VERIFY	CONCLUSION
BODY DC HIGH (Max Limit)	[Display CVs]: p3 = 4767 [Accept] [Download] [Manual Prescan].	Do not change TG.	Laptop or SSM LED indicates monitor faulted. <input type="checkbox"/> Pass <input type="checkbox"/> Fail	[Done], Place both monitor switches to RESET , then BYPASS . On laptop, press 'C' to continue.
BODY DC LOW (Min Limit)	[Display CVs]: p3 = 750 dcset = 25 [Accept] [Download] [Manual Prescan].	Do not change TG.	SENSE LEDs (both blinking), <input type="checkbox"/> Pass <input type="checkbox"/> Fail	[Done].
BODY DC LOW (Max Limit)	[Display CVs]: p3 = 917 [Accept] [Download] [Manual Prescan].	Do not change TG.	Laptop or SSM LED indicates monitor faulted. <input type="checkbox"/> Pass <input type="checkbox"/> Fail	[Done], Place both monitor switches to RESET , then BYPASS . On laptop, press 'C' to continue.
<p>Note 1: Wattmeter reading must be multiplied by Cable Attenuation factor from Table 2-13, Set Up and Calibration tab. Note 2: If necessary, increase TG until SENSE LEDs come on. No more than 5 kW should be necessary.</p>				

2-4-3 Body Checks (continued)

TABLE 2-18
BODY CHECKS (1.0T)

TEST	SCAN CONDITIONS	ADJUSTMENTS (Note 1)	VERIFY	CONCLUSION
BODY PEAK POWER HIGH	[Display CVs] calmode = 2 trig = 7 aset = 110 [Accept] [Download] [Manual Prescan].	Increase Transmit Gain (TG) until laptop or SSM LED indicates fault occurred on one of the monitors; measure Power. Continue increasing TG until laptop or SSM LED indicates other monitor has faulted; measure Power.	Power is within specifications: Min: 4100W or 66.1dBm Max: 4500W or 66.5dBm Nom: 4300W or 66.3dBm <input type="checkbox"/> Pass <input type="checkbox"/> Fail	Set TG to 0 [Done]. Place both monitor switches to RESET, then BYPASS. On the laptop, press 'C' to continue.
BODY PEAK POWER LOW	[Display CVs] aset = 30 [Accept] [Download] [Manual Prescan].	Increase TG until first FAULT LED on; measure Power. Continue increasing TG until other FAULT LED on, measure Power.	Power is within specifications: Min: 1100W or 60.4dBm Max: 1300W or 61.1dBm Nom: 1200W or 60.8dBm <input type="checkbox"/> Pass <input type="checkbox"/> Fail	Set TG to 0 [Done]. Place both monitor switches to RESET, then BYPASS. On the laptop, press 'C' to continue.
BODY PULSE WIDTH(PW) HIGH (Min Limit)	[Display CVs] calmode = 1 p1 = 3912 aset = 255 pwset = 35 [Accept] [Download] [Manual Prescan].	Increase TG (from 0) until Power measures 2 - 3Kw. (Note 1)	SENSE LEDs (both blinking), BODY LEDs (both ON), FAULT LEDs (both OFF) <input type="checkbox"/> Pass <input type="checkbox"/> Fail	[Done].
BODY PW HIGH (Max Limit)	[Display CVs] p1 = 4324 [Accept] [Download] [Manual Prescan].	Do not change TG.	FAULT LEDs (both ON) <input type="checkbox"/> Pass <input type="checkbox"/> Fail	[Done], Place both monitor switches to RESET, then BYPASS. On the laptop, press 'C' to continue.
BODY PW LOW (Min Limit)	[Display CVs] p1 = 1076 pwset=10 [Accept] [Download] [Manual Prescan].	Do not change TG.	SENSE LEDs (both blinking), BODY LEDs (both ON), FAULT LEDs (both OFF) <input type="checkbox"/> Pass <input type="checkbox"/> Fail	[Done].
BODY PW LOW (Max Limit)	[Display CVs] p1 = 1276 [Accept] [Download] [Manual Prescan].	Do not change TG.	FAULT LEDs (both ON) <input type="checkbox"/> Pass <input type="checkbox"/> Fail	[Done], Place both monitor switches to RESET, then BYPASS. On the laptop, press 'C' to continue.
BODY DUTY CYCLE (DC) HIGH (Min Limit)	[Display CVs] calmode = 3 t3=33333 TR_SLOP=0 p3 = 3900 pwset = 255 dcset = 130 [Accept] [Download] [Manual Prescan].	Do not change TG.	SENSE LEDs (both blinking), BODY LEDs (both ON), FAULT LEDs (both OFF) (Note 2) <input type="checkbox"/> Pass <input type="checkbox"/> Fail	[Done].
BODY DC HIGH (Max Limit)	[Display CVs] p3 = 4767 [Accept] [Download] [Manual Prescan].	Do not change TG.	FAULT LEDs (both ON) (Note 2) <input type="checkbox"/> Pass <input type="checkbox"/> Fail	[Done], Place both monitor switches to RESET, then BYPASS. On the laptop, press 'C' to continue.

2-4-3 Body Checks (continued)

TABLE 2-18 (CONTINUED)
 BODY CHECKS (1.0T)

TEST	SCAN CONDITIONS	ADJUSTMENTS (Note 1)	VERIFY	CONCLUSION
BODY DC LOW (Min Limit)	[Display CVs] p3 = 750 dcset = 25 [Accept] [Download] [Manual Prescan].	Do not change TG.	SENSE LEDs (both blinking), BODY LEDES (both ON), FAULT LEDs (both OFF) (Note 2) <input type="checkbox"/> Pass <input type="checkbox"/> Fail	[Done].
BODY DC LOW (Max Limit)	[Display CVs] p3 = 917 [Accept] [Download] [Manual Prescan].	Do not change TG.	FAULT LEDs (both ON) (Note 2) <input type="checkbox"/> Pass <input type="checkbox"/> Fail	[Done], Place both monitor switches to RESET, then BYPASS. On the laptop, press 'C' to continue.

Note 1: If necessary, increase TG until both SENSE and both BODY LEDs come on. No more than 1 kW should be necessary.

Note 2: Allow at least 12 seconds after looping starts before checking status of FAULT LEDs.

2-4-4 Head Checks

Tests in this section allow the service engineer to selectively force head mode peak power, pulse width, and duty cycle beyond allowable limits.

1. **1.5T:** Connect dummy load and wattmeter (2.5 kW element) to the head output of the cabinet. See Illustration 2-27 or Illustration 2-28 (RF Power Kit).

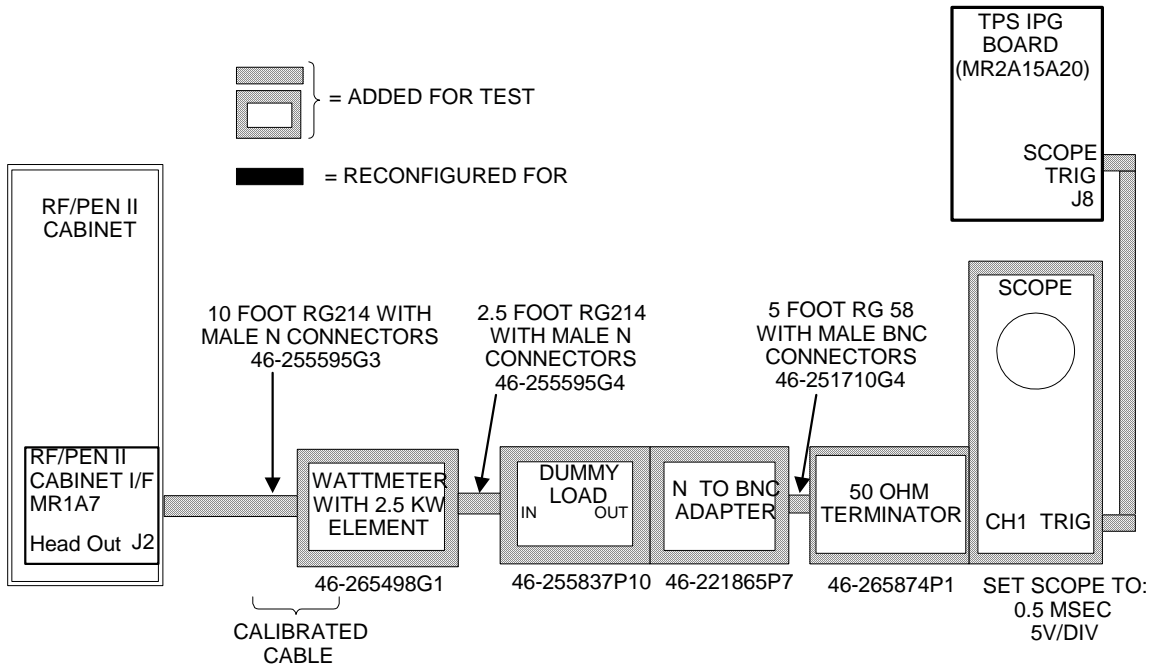

RECONFIGURATION FOR HEAD CHECKS (1.5T)
 ILLUSTRATION 2-27

2-4-4 Head Checks (continued)

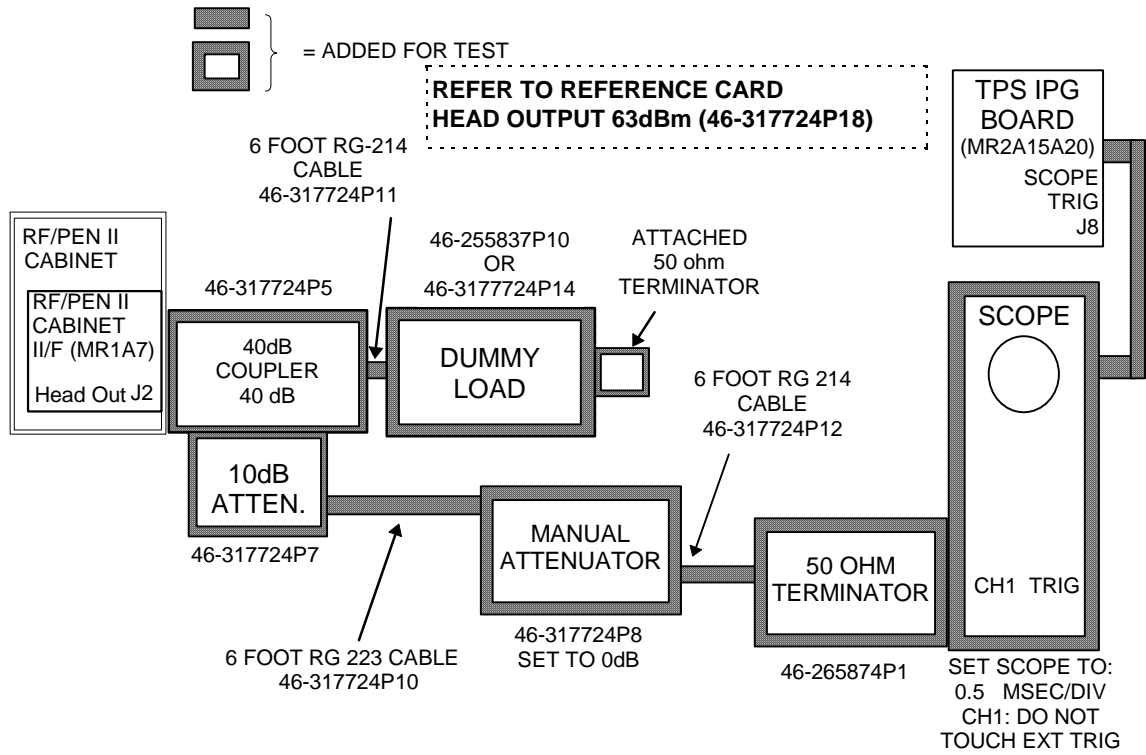

RECONFIGURATION FOR HEAD CHECKS USING RF POWER MEASUREMENT KIT (1.5T)
 ILLUSTRATION 2-28

2-4-4 Head Checks (continued)

- 1.0T: Connect dummy load to the head output of the cabinet. See Illustration 2-29 or Illustration 2-30.

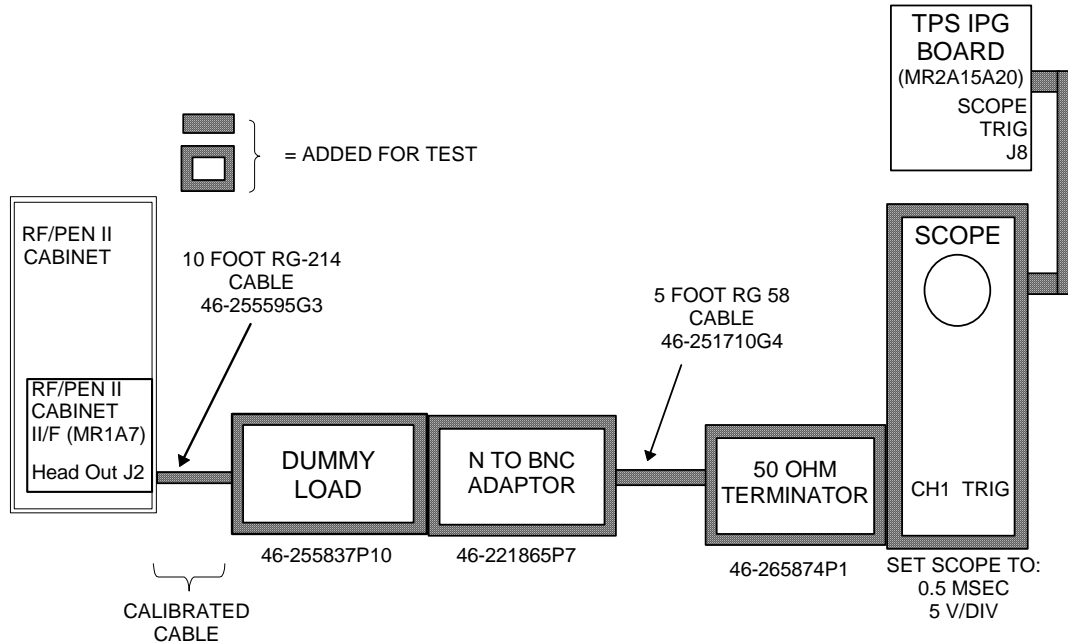

RECONFIGURATION FOR HEAD CHECKS (1.0T)
ILLUSTRATION 2-29

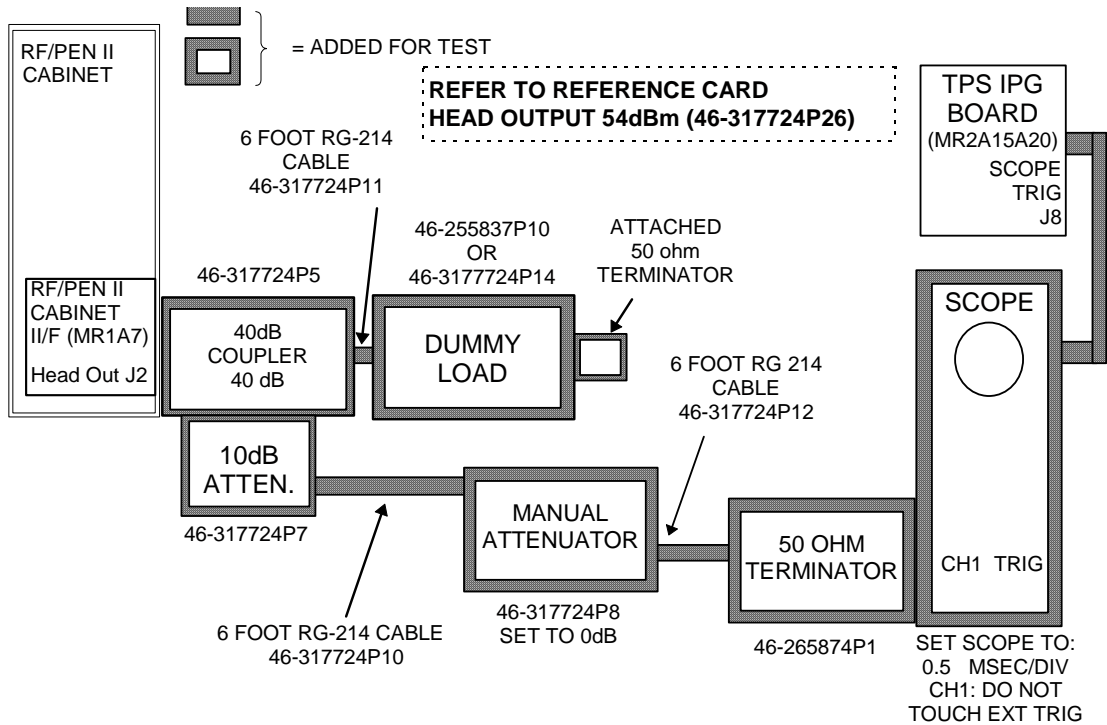

RECONFIGURATION FOR HEAD CHECKS USING RF POWER MEASUREMENT KIT (1.0T)
ILLUSTRATION 2-30

2-4-4 Head Checks (continued)

3. At the operator workspace, prepare the system for a Head Power Monitor scan using the "Service Protocols" procedure; refer to Table 2-19.

TABLE 2-19
SCAN PRESCRIPTION - HEAD PM CHECKS

Note: This is the alternate proprietary procedure available for GE use, and to sites with a valid Advanced Service Package Limited License.

- A. **[New Pt]**
 Id: **geservice <ENTER>**
 Name: **pmc**
 Weight (Lb.): **300**
 Set Patient Protocols to **Service**.
- B. At front enclosure:
 Landmark in the Head area—remove any coils.
 press **LANDMARK**.
 press **MOVE TO SCAN**.
- C. **New Series]**
 At Patient Protocols – select **other**.
- D. At Patient Protocols – select **other**.
- E. In the protocol field, type **o.23.1<ENTER>** (o=Other, 23.1 =series) to load the head protocol
OR select **[o.23] [Series 1] [Accept]**.
[OK] (if required).
- F. **[Save Series]**
- G. **[Prepare to Scan]**.
- H. **[Research Operations]**.
[Setup Params]. Set Plot to **OFF**. Set **TG** to **50**. **[Done]**.
- I. **[Research Operations]**.
[Display CVs]. Highlight CV Name and enter the following:
 CV name: **see appropriate Table<ENTER>, see appropriate Table <ENTER>**
[Accept].
- J. **[Research Operations] [Download]**.
- K. **[Prepare to Scan]**.
- L. Select **[Manual Prescan]**.

4. Perform head checks as per Table 2-20 (1.5T) or Table 2-21 (1.0T).

Note

All setpoint values are selected by modifying control variables. Instructions are provided in the Scan Conditions column in Table 2-20 (1.5T) or Table 2-21 (1.0T).

Note

Wattmeter reading must be multiplied by cable attenuation factor of cables between the RF amplifier and the wattmeter.

Note

Oscilloscope reading must be multiplied by dummy load and cable(s) attenuation factor between the RF amplifier and the oscilloscope.

2-4-4 Head Checks (continued)

TABLE 2-20
HEAD CHECKS (1.5T)

TEST	SCAN CONDITIONS	ADJUSTMENTS (Note 1)	VERIFY	CONCLUSION
HEAD PEAK POWER HIGH	[Display CVs]: calmode = 2 trig = 7 aset = 120 [Accept] [Download] [Manual Prescan].	Increase Transmit Gain (TG) until, first FAULT LED on, measure Power. Continue increasing TG until laptop or SSM LED indicates other monitor has faulted; measure power.	Power is within specifications: Min: 1318W or 61.2dBm Max: 1784W or 62.5dBm Nom: 1551W or 61.9dBm <input type="checkbox"/> Pass <input type="checkbox"/> Fail	Set TG to 0 [Done] Place both MONITOR switches to RESET , then BYPASS . On laptop, press 'C' to continue.
HEAD PEAK POWER LOW	[Display CVs]: aset = 30 [Accept] [Download] [Manual Prescan].	Increase Transmit Gain (TG) until, first FAULT LED on; measure Power. Continue increasing TG until other FAULT LED on; measure Power.	Power is within specifications: Min: 330W or 55.2dBm Max: 446W or 56.5dBm Nom: 388W or 55.9dBm <input type="checkbox"/> Pass <input type="checkbox"/> Fail	Set TG to 0 [Done] Place both MONITOR switches to RESET , then BYPASS . On laptop, press 'C' to continue.
HEAD PULSE WIDTH(PW) HIGH (Min Limit)	[Display CVs]: calmode = 1 p1 = 4750 aset = 255 pwset = 100 [Accept] [Download] [Manual Prescan].	Increase TG (from 0) until Power measures 200 - 300W. (Note 2)	SENSE LEDs (both blinking), FAULT LEDs (both OFF) <input type="checkbox"/> Pass <input type="checkbox"/> Fail	[Done]
HEAD PW HIGH (Max Limit)	[Display CVs]: p1 = 5250 [Accept] [Download] [Manual Prescan].	Do not change TG.	FAULT LEDs (both ON) <input type="checkbox"/> Pass <input type="checkbox"/> Fail	[Done] Place both MONITOR switches to RESET , then BYPASS . On laptop, press 'C' to continue.
HEAD PW LOW (Min Limit)	[Display CVs]: p1 = 400 pwset=10 [Accept] [Download] [Manual Prescan].	Do not change TG.	SENSE LEDs (both blinking), HEAD LEDES (both ON), FAULT LEDs (both OFF) <input type="checkbox"/> Pass <input type="checkbox"/> Fail	[Done]
HEAD PW LOW (Max Limit)	[Display CVs]: p1 = 600 [Accept] [Manual Prescan].	Do not change TG.	FAULT LEDs (both ON) <input type="checkbox"/> Pass <input type="checkbox"/> Fail	[Done] , Place both MONITOR switches to RESET , then BYPASS . On laptop, press 'C' to continue.
HEAD DUTY CYCLE (DC) HIGH (Min Limit)	[Display CVs]: calmode = 3 TR_SLOP= 0 t3=33333 p3 = 3900 pwset = 255 dcset = 130 [Accept] [Download] [Manual Prescan].	Do not change TG.	SENSE LEDs (both blinking), FAULT LEDs (both OFF) (Note 3) <input type="checkbox"/> Pass <input type="checkbox"/> Fail	[Done]
HEAD DC HIGH (Max Limit)	[Display CVs]: p3 = 4767 [Accept] [Download] [Manual Prescan].	Do not change TG.	FAULT LEDs (both ON) (Note 3) <input type="checkbox"/> Pass <input type="checkbox"/> Fail	[Done] , Place both MONITOR switches to RESET , then BYPASS . On laptop, press 'C' to continue.

2-4-4 Head Checks (continued)

TABLE 2-20(continued)
 HEAD CHECKS (1.5T)

TEST	SCAN CONDITIONS	ADJUSTMENTS (Note 1)	VERIFY	CONCLUSION
HEAD DC LOW (Min Limit)	[Display CVs]: p3 = 750 dcset = 25 [Accept] [Download] [Manual Prescan].	Do not change TG.	SENSE LEDs (both blinking), FAULT LEDs (both OFF) (Note 3) <input type="checkbox"/> Pass <input type="checkbox"/> Fail	[Done]
HEAD DC LOW (Max Limit)	[Display CVs]: p3 =917 [Accept] [Download] [Manual Prescan]	Do not change TG.	FAULT LEDs (both ON) (Note 3) <input type="checkbox"/> Pass <input type="checkbox"/> Fail	[Done], Place both MONITOR switches to RESET, then BYPASS. On laptop, press 'C' to continue.
<p>Note 1: Wattmeter reading must be multiplied by Cable Attenuation factor from <i>Dummy Load & Cables Calibration</i> procedure under Appendix A.</p> <p>Note 2: If necessary, increase TG until SENSE LEDs come on. No more than 500 Watts should be necessary.</p> <p>Note 3: Allow at least 12 seconds after looping starts before checking status of FAULT LEDs.</p>				

2-4-4 Head Checks (continued)

TABLE 2-21
HEAD CHECKS (1.0T)

TEST	SCAN CONDITIONS	ADJUSTMENTS (Note 1)	VERIFY	CONCLUSION
HEAD PEAK POWER HIGH	[Display CVs]: calmode = 2 trig = 7 aset = 50 [Accept] [Download] [Manual Prescan].	Increase Transmit Gain (TG) until laptop or SSM LED indicates fault occurred on one of the monitors; measure power. Continue increasing TG until laptop or SSM LED indicates other monitor has faulted; measure power.	Power is within specifications: Min: 160W or 52dBm Max: 240W or 53.8dBm Nom: 200W or 53dBm <input type="checkbox"/> Pass <input type="checkbox"/> Fail	Set TG to 0[Done] Place both monitor switches to RESET , then BYPASS . On laptop, press 'C' to continue.
HEAD PEAK POWER LOW	[Display CVs]: aset = 30 [Accept] [Download] [Manual Prescan].	Increase Transmit Gain (TG) until, first FAULT LED on; measure power. Continue increasing TG until other FAULT LED on; measure power.	Power is within specifications: Min: 100W or 50dBm Max: 136W or 51.3dBm Nom: 117W or 50.7dBm <input type="checkbox"/> Pass <input type="checkbox"/> Fail	Set TG to 0[Done]. Place both monitor switches to RESET , then BYPASS . On laptop, press 'C' to continue.
HEAD PULSE WIDTH(PW) HIGH (Min Limit)	[Display CVs]: calmode = 1 p1 = 3912 aset = 255 pwset = 35 [Accept] [Download] [Manual Prescan].	Increase TG (from 0) until Power measures 50 - 70W. (Note 1)	SENSE LEDs (both blinking), HEAD LEDs (both ON), FAULT LEDs (both OFF) <input type="checkbox"/> Pass <input type="checkbox"/> Fail	[Done].
HEAD PW HIGH (Max Limit)	[Display CVs]: p1 = 4324 [Accept] [Download] [Manual Prescan].	Do not change TG.	FAULT LEDs (both ON) <input type="checkbox"/> Pass <input type="checkbox"/> Fail	[Done], Place both monitor switches to RESET , then BYPASS . On laptop, press 'C' to continue.
HEAD PW LOW (Min Limit)	[Display CVs]: p1 = 1076 pwset=10 [Accept] [Download] [Manual Prescan].	Do not change TG.	SENSE LEDs (both blinking), HEAD LEDs (both ON), FAULT LEDs (both OFF) <input type="checkbox"/> Pass <input type="checkbox"/> Fail	[Done]
HEAD PW LOW (Max Limit)	[Display CVs]: p1 = 1276 [Accept] [Download] [Manual Prescan].	Do not change TG.	FAULT LEDs (both ON) <input type="checkbox"/> Pass <input type="checkbox"/> Fail	[Done], Place both monitor switches to RESET , then BYPASS . On laptop, press 'C' to continue.
HEAD DUTY CYCLE (DC) HIGH (Min Limit)	[Display CVs]: calmode = 3 TR_SLOP=0 t3=33333 p3 = 3900 pwset = 255 dcset = 130 [Accept] [Download] [Manual Prescan].	Do not change TG.	SENSE LEDs (both blinking), HEAD LEDs (both ON), FAULT LEDs (both OFF) (Note 2) <input type="checkbox"/> Pass <input type="checkbox"/> Fail	[Done].
HEAD DC HIGH (Max Limit)	[Display CVs]: p3 = 4767 [Accept] [Download] [Manual Prescan].	Do not change TG.	FAULT LEDs (both ON) (Note 2) <input type="checkbox"/> Pass <input type="checkbox"/> Fail	[Done], Place both monitor switches to RESET , then BYPASS . On laptop, press 'C' to continue.

2-4-4 Head Checks (continued)

TABLE 2-21
 HEAD CHECKS (1.0T)

TEST	SCAN CONDITIONS	ADJUSTMENTS (Note 1)	VERIFY	CONCLUSION
HEAD DC LOW (Min Limit)	[Display CVs]: p3 = 750 dcset = 25 [Accept] [Download] [Manual Prescan] .	Do not change TG.	SENSE LEDs (both blinking), HEAD LEDES (both ON), FAULT LEDs (both OFF) (Note 2) <input type="checkbox"/> Pass <input type="checkbox"/> Fail	[Done] .
HEAD DC LOW (Max Limit)	[Display CVs]: p3 = 917 [Accept] [Download] [Manual Prescan] .	Do not change TG.	FAULT LEDs (both ON) (Note 2) <input type="checkbox"/> Pass <input type="checkbox"/> Fail	[Done] , Place both monitor switches to RESET , then BYPASS . On laptop, press 'C' to continue.
<p>Note 1: If necessary, increase TG until both SENSE and both HEAD LEDs come on. No more than 100 Watts should be necessary. Note 2: Allow at least 12 seconds after looping starts before checking status of FAULT LEDs.</p>				

2-4-5 Amplifier Shutdown Verification

Tests in this section verify that each power monitor is capable of shutting down the amplifier independently of the other and further verify both the logic and relay shutdowns for each channel. Setpoints are not checked in this section.

When one or both of the monitors is in bypass mode, the HV relay shutdown is disabled.

1. Disable power monitor B by placing the monitor B switch on the front panel of the SSM in the Bypass position.
2. At the operator work space, prepare the system for a Amp Shutdown Verification scan using the "Service Protocols" procedure located under **[Tools]** menu on the service methods CD-ROM, or for the alternate proprietary procedure; refer Table 2-22.

Note

Verify that the Head Coil has been removed from the patient table before continuing.

TABLE 2-22
 ALTERNATE PROPRIETARY PROCEDURE — AMP SHUTDOWN

1. Click on **[New Pt]**, and **<Enter>**.
 Id: **geservice**
 Name: **amplifier shutdown**
 verification
 Weight (lb): **300**
 Set Patient Protocols to **Service**
 At front of enclosure, press **LANDMARK**, then **MOVE TO SCAN**.
2. In the protocol field, type **o.23.3** (o=Other, 3=Series) to load the protocol.
3. **[Save Series]**
4. Select **[Research Operations]** with the mouse cursor and the right mouse button. Select **[Display CVs]**. Highlight the CV Name field. Type in the word **dcset**. Press **<Enter>**.
 Repeat step 4 to enter the following CVs:

dcset	255
aset	30
calmode	2
trig	1
5. **[Accept]**.
 With the right mouse button, select **Research Operations. Download. Prepare to Scan.**

3. **[Manual Prescan]** (Do not exit *Manual Prescan* until step 12.)
4. Increase transmit gain (TG) until wattmeter reads 0.5 to 1kW.

2-4-5 Amplifier Shutdown Verification (continued)

5. Continue increasing TG until monitor A FAULT LED illuminates. Quickly verify the following:
 - The FAULT LED on for monitor A (resets automatically after two seconds).
 - RF amplifier is shut down and is displaying fault code 84 or 85. (IPER will reset the amplifier 10 to 15 seconds after the power monitor fault clears, i.e., a few seconds after the FAULT LED turns off on the amplifier.)
 - Wattmeter reads zero RF power (press FWD PED, then MAX).

Note

Do not perform any operations at the scan touch screen or keyboard while In Place Error Recovery (IPER) is resetting the RF amplifier.

6. While waiting for the RF amplifier to recover, place monitor B in normal mode by placing the monitor B switch on the front panel of the SSM in the Normal position. Now both monitors A and B should be in normal mode.
7. After IPER has reset the RF amplifier, first decrease TG by 50 counts (5dB), then press START SCAN on the operator's console to initiate looping.

8. Increase TG until the FAULT LED for monitor A or B illuminates. Quickly verify the following:
 - FAULT LED on for monitor A or B (resets automatically after two seconds).
 - RF amplifier is shut down and is displaying fault code 84 or 85. (IPER will reset the amplifier 10 to 15 seconds after the power monitor fault clears, i.e., a few seconds after the FAULT LED goes off on the amplifier.)

Note

Software will log an 84 or 85 fault in the message log.

- Wattmeter reads zero RF power (press FWD PED, then MAX).

Note

Do not perform any operations at the scan touch screen or keyboard while In Place Error Recovery (IPER) is resetting the RF amplifier.

9. While waiting for the amplifier to recover, disable power monitor A by placing the monitor A switch on the front panel of the SSM in the Bypass position.
10. After IPER has reset the RF amplifier, first decrease TG by 50 counts (5dB), then press START SCAN on the operator's console to initiate looping.

2-4-5 Amplifier Shutdown Verification (continued)

11. Increase TG until monitor B FAULT LED illuminates. Quickly verify the following:
 - FAULT LED on for monitor B (resets automatically after two seconds).
 - RF amplifier is shut down and is displaying fault code 84 or 85. (IPER will reset the amplifier 10 to 15 seconds after the power monitor fault clears, i.e., as soon as the FAULT LED turns off on the amplifier.)
 - Wattmeter reads zero RF power (press FWD PED, then MAX).

Note

Do not perform any operations at the scan touch screen or keyboard while In Place Error Recovery (IPER) is resetting the RF amplifier.

12. After IPER has reset the RF amplifier, select **[Done]**.
13. **[Set Up Parameters]** and turn power spectrum on.
14. In the Rx Manager, select **[End Exam]**.

2-4-6 Declaration Form Preparation

1. Prepare Direction 2212503, *Signa Horizon Power Monitor Functional Test Declaration*.
2. File completed declaration form per current company policy.

2-4-7 System Restoration

1. In the Test Window place switches 1-4 in the down position and replace the LED cover on the front of the SSM. See Illustration 2-31.

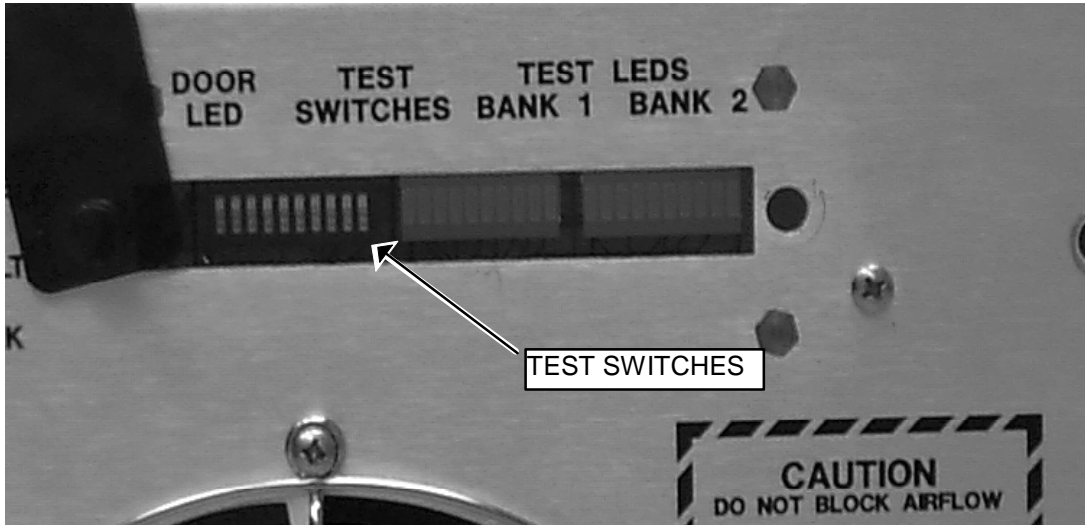

INSIDE THE TEST WINDOW
ILLUSTRATION 2-31

2. On the front panel of the SSM, place the two monitor switches in the Normal position, and place the three DRV FLT switches in the enable faults position (EN). See Illustration 2-32.

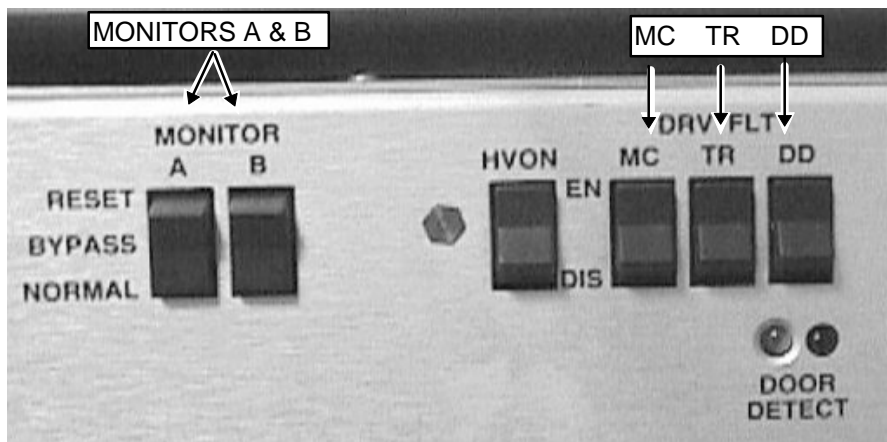

FRONT PANEL SWITCHES ENABLED
ILLUSTRATION 2-32

3. Ensure that the dummy load and wattmeter are disconnected from the rear of the cabinet.
4. Ensure that the head and body heliax cables are reconnected to the rear of the cabinet.

5. Reconnect BNC cables to RF IN (J3) and EFB RF OUT (J103). See Illustration 2-33.

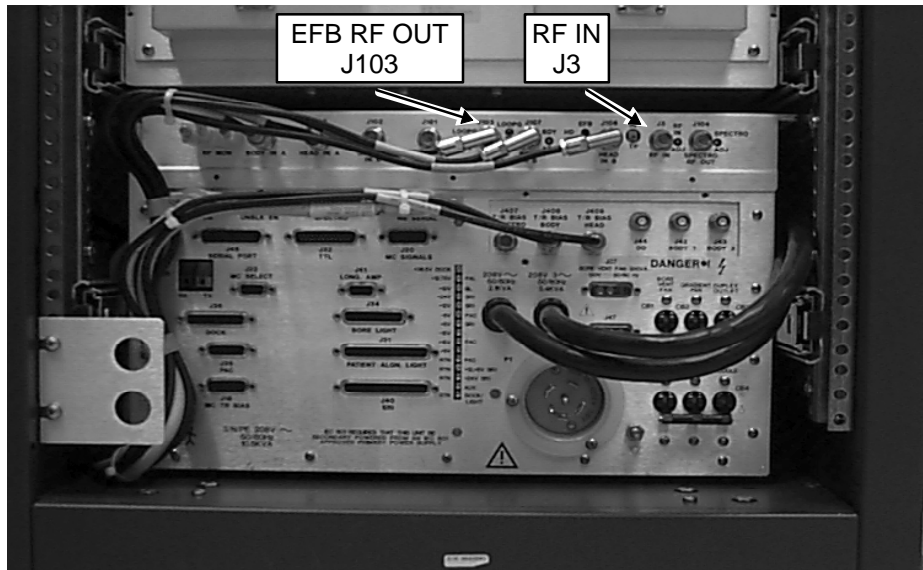

J103 AND J3 LOCATIONS
 ILLUSTRATION 2-33

Note

If using the Laptop perform the following steps to exit MONS.EXE and return to Windows:

- A) Follow screen directions to return to DOS.
- B) At the DOS C:\CCLASS\ERBTEC> prompt, type **EXIT<ENTER>**.

6. Place the first four DIP switches of the Test Switches in the DOWN position or disconnect laptop computer from J46 on the rear of the SSM.
7. Complete one head scan satisfactorily.
8. Complete one body scan satisfactorily.
9. Replace the front door on the cabinet.

2-5 Perform Power Monitor Functional Checks—RF/PDU & SRF Cabinets

This section applies to systems installed with the 1.0T/1.5T RF/PDU & SRF Cabinets.

Use this procedure to ensure that the power monitors are fully functional, including redundant trip capability. The tests described use a special PSD (pulse sequence data base) to provide excitation for the RF amplifier. The PSD allows the service engineer to selectively force peak power, pulse width, and duty cycle beyond allowable limits. Select set points for testing by modifying Control Variables that override the values normally calculated and downloaded by the PSD.

Power Monitor firmware operation is changed to bypass/test mode by moving “monitor” switches (A and B) on the front of the SSM. This action permits set-point verification without tripping the RF amplifier, thereby eliminating the time consuming necessity of resetting the amplifier after each trip. It is necessary to measure the RF output power and know at what level each monitor tripped.

Three methods are available and listed in the order of preference for measuring head and body RF output power:

- **RF Power Measurement Kit** - Easy to use, preferred method of power measurement.
- **Bird wattmeter** - Must account for cable and load loss to determine actual power.
- **Oscilloscope** - Must know the scope channel correction factor if the scope bandwidth is < 300 MHz. Must account for cable and dummy load loss and the scope bandwidth limitation (channel correction factor) to accurately calculate the power from the observed peak voltage. This method works but the process used to derive the power is somewhat complex and lacks the accuracy of the previous two methods. It is, for this reason, not recommended.

It is *strongly recommended* that the RF Power Measurement Kit be used to obtain an accurate measurement of the RF output power. If it is not possible to obtain an RF Power Measurement Kit then one of the two other methods can be used provided that:

- The Dummy Load and Cables Calibration procedure in Appendix A has been performed and the individual loss values are known.
- The oscilloscope input channel correction factor is known when the scope bandwidth is < 300 MHz *and* the wattmeter is not being used. See Appendix J.



FAILURE TO ACCOUNT FOR THE ACTUAL LOSSES IN THE DUMMY LOAD, CABLES, AND OSCILLOSCOPE WHEN NOT USING THE RF POWER MEASUREMENT KIT TO MEASURE RF POWER CAN RESULT IN SIGNIFICANT MEASUREMENT ERRORS.

After checking the set points, the actual shutdown of the amplifier is verified: once for monitor A, once for monitor B, and once for the HV relay shutdown. The actual shutdown of the amplifier is verified twice for monitor A (to verify both relay and logic shutdowns), and once for monitor B (connected to amplifier via monitor A). This also confirms that the bypass/test “monitor” switches (A and B) are restored prior to returning the system to normal operation.

2-5-1 Tools And Instruments Required

Table 2-23 describes what tools are necessary if the RF Power Measurement Kit is NOT used. Table 2-24 describes all the necessary tools needed if the RF Power Measurement Kit is used.

The use of the RF Power Measurement Kit to complete the RF Power Monitor Check is highly recommended.

TABLE 2-23
TOOLS AND INSTRUMENTS REQUIRED WITHOUT RF POWER MEASUREMENT KIT

Item	Description	Part Number
1.	RF Test Cables Kit	46-255816G1
2.	50 ohm, 200 Watt, 30 dB attenuator - Bird Model 8322	46-255837P10
3.	Oscilloscope	46-183029P61
4.	Wattmeter and appropriate elements (optional)	Not supplied

TABLE 2-24
TOOLS AND INSTRUMENTS REQUIRED WITH RF POWER MEASUREMENT KIT

Item	Description	Part Number
1.	RF Power Measurement Kit	46-317724G1 or G2
2.	50 ohm, 200 Watt, 30 dB attenuator - Bird Model 8322 NOTE: Only required with G1 Kit	46-255837P10
3.	Oscilloscope	46-183029P61

2-5-2 Hardware Preparation

Perform the prerequisite calibration procedures in the sequence listed in Table 2-25.

Table 2-25
PRE — REQUISITE PROCEDURES

Step	Procedure Title	When Required
1a	Dummy Load & Cables Calibration – Appendix A (Do if NOT using the RF Power Measurement Kit)	Calibration required whenever using the dummy load and cables. This value will be frequency specific and can change over time.
1b	Scope characterization – Appendix J (Do if NOT using the RF Power Measurement Kit)	This should be done for scopes with bandwidths less than 300 MHz.
2	RF/PDU Max Power RF Out Setup and Calibration (RC3SCA1.DOC on Service Methods CDROM)	At initial installation or when the RFI, UCERD Exciter, or RF Amps are repaired or replaced.



PREVENT EQUIPMENT DAMAGE. ENSURE THAT THE RF AMPLIFIER HAS A DUMMY LOAD CONNECTED TO ITS OUTPUT BEFORE INITIATING TESTS. IF NOT, FAULTS MAY OCCUR AND RF AMPLIFIER COMPONENTS COULD BE PERMANENTLY DAMAGED.

Pre-requisite Status

Pre-requisite — Signa must be fully functional and properly calibrated.

Pre-requisite — Software must be running with the system capable of normal imaging.

2-5-2 Hardware Preparation (Continued)

1. Verify that the system is not scanning and that all coils have been removed from the magnet bore. See the **DANGER** message on this page.



PROPERTY DAMAGE! TO PREVENT COIL AND ASSOCIATED SWITCH DAMAGE, REMOVE ALL PHANTOMS AND HARDWARE (I.E., HEAD COIL, SURFACE COIL...) FROM THE MAGNET BORE.

2. Remove the front cover from the RF/PDU Cabinet.
3. See Illustration 2-34. On the front of the SSM place the:
 - 2 (two) power MONITOR switches (A and B) to the middle BYPASS position.
 - 3 (three) DRV FLT switches to the bottom DIS (disable faults) position.

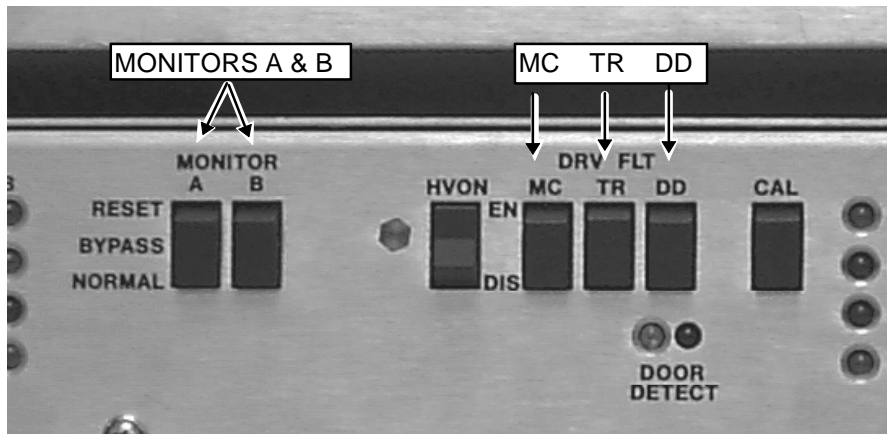

SSM FRONT PANEL SWITCHES DISABLED
 ILLUSTRATION 2-34

4. Remove the test window from the Test Switches and Test LEDs on the front of the SSM. See Illustration 2-35.

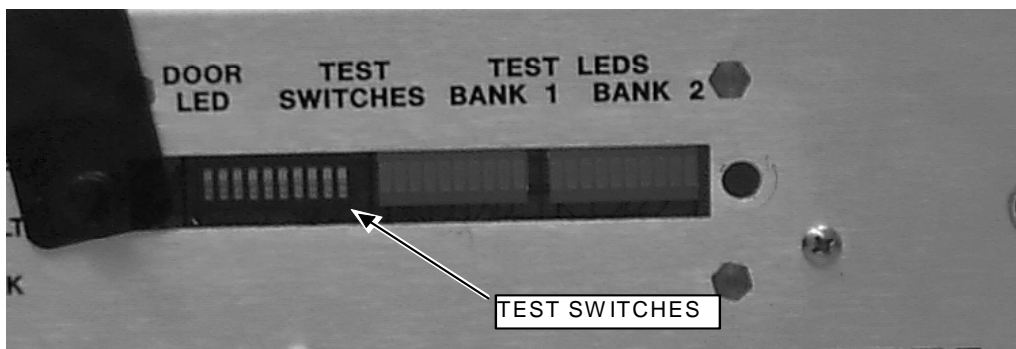

INSIDE THE TEST WINDOW
 ILLUSTRATION 2-35

2-5-2 Hardware Preparation (continued)

Note

Order of DIP switch placement is important otherwise the system will not recognize changes.

- 5. Place the first four switches in the order and positions shown in Table 2-26 and leave in these positions for the duration of the test.

TABLE 2-26
 SWITCH POSITIONS

SWITCH NUMBER	POSITION
2	UP
3	DOWN
4	UP
1	UP

- 6. The TEST LED will illuminate. This is the yellow LED to the right of the CAL switch.
- 7. **If you are using the RF Power Measurement Kit** then calibrate the scope by referring to the RF Power Measurement Kit laminated card set.
 - a. Look in the upper right corner of each card and find the card labeled **CAL**.
 - b. Configure the scope as in the illustration on the card.
 - c. Follow the directions on the card to calibrate the scope using the 4 dBm calibrator.
- 8. **If you are not using the RF Power Measurement Kit** then complete the Dummy Load and Cables Calibration procedure in Appendix A. If using the scope to measure the RF output power then also make sure that the scope correction factor has been determined for the input channel to be used as described in Appendix J.

2-5-3 Body Checks

Tests in this section allow the service engineer to selectively force body mode peak power, pulse width, and duty cycle beyond allowable limits.



PROPERTY DAMAGE! PREVENT COIL AND ASSOCIATED SWITCH DAMAGE, BY REMOVING ALL PHANTOMS AND HARDWARE (I.E., HEAD COIL, SURFACE COIL...) FROM THE MAGNET BORE.

1. Confirm that all the steps in **Section 2-5-2 - Hardware Preparation** - have been done.
2. Verify that the system is not scanning and that all coils have been removed from the magnet bore. See the two **DANGER** messages on this page.



PERSONAL INJURY! PREVENT POSSIBLE RF BURNS WHEN DISCONNECTING HELIAX CABLES FROM J3 OR J4 ON THE RFI BY VERIFYING THAT THE SYSTEM IS NOT MANUALLY PRESCANNING OR SCANNING. VERIFY THAT THE SCAN DESKTOP ICON DISPLAYS THE "IDLE" MESSAGE.



1.

3. **If using the RF Power Measurement Kit** then refer to the RF Power Measurement Kit laminated card set.
 - a. Look in the upper, right corner of each card and find the card labeled **72** (1.5T Body Output) or find the card labeled **68.8** (1.0T Body Output)



The body RF output connection is no longer to the non-existent EFB unit, as the older reference cards from the kit show, but instead to the J4 output on the rear of the RFI. An RF adapter is provided in the RF Power Measurement Kit to connect between the HN J4 body RF output and the RF Power Measurement Kit 40 dB N-connector coupler.

- b. Configure the system as in the illustration on the card.
 - c. Confirm that the rotary attenuator is set to the correct position indicated on the card.
4. **If using the wattmeter or scope** (NOT the RF Power Measurement Kit) to measure power then refer to Appendix B (Alternate Equipment Setup) in the RF Power Monitor Check procedure in the LX Service Methods, for the proper system body configuration.
5. At operator workspace, select the scan desktop ICON in the desktop control panel, if you have not already done so.

2-5-3 Body Checks (Continued)

- At the operator workspace, prepare the system for a Body Power Monitor scan using the "Service Protocols" procedure in Table 2-27 below. Refer to Appendix B for the non-proprietary protocol.

Table 2-27
SCAN PRESCRIPTION - BODY PM CHECKS

Note: This is the alternate proprietary procedure available for GE use, and to sites with a valid Advanced Service Package Limited License. Refer to Appendix B for the non-proprietary protocol.

[New Series]

At Patient Protocols – select **other**.

In the protocol field, type **o.23.2<ENTER>** (o=Other, 23.2 =series) to load the body protocol

OR select **[o.23] [Series 2] [Accept]**.

[OK] (if required).

[Save Series].

[Prepare to Scan].

[Research Operations].

[Setup Params]. Set **TG** to **50**. **[Done]**.

[Research Operations].

[Display CVs]. Highlight CV Name and enter the following:

CV name: **dcset <ENTER>, 255 <ENTER>**

CV name: **t3 <ENTER>, 20000 <ENTER>**

[Accept].

[Research Operations]

[Download]

- Refer to Table 2-28 for 1.5T Systems or Table 2-29 for 1.0T Systems. Note that the tables consists of 5 columns (**Test, Scan Conditions, Adjustments, Verify, Conclusion**) and 10 individual rows of various head power tests.

Note

It may be advantageous at this point to print a hard copy of Table 2-28 or Table 2-29. This will provide a quick reference and also a place for making notations.

- Start at the first **Test** row in Table 2-28 or Table 2-29. Under the **Scan Conditions** column highlight or type-in the CVs into the CV Name box and then enter the listed corresponding number into the Current Value box. Right mouse-click on the remaining items listed in the column.
- Advance to the **Adjustments** column on the right and perform the directions listed in the column. Refer to the following steps for measuring the RF output power.

2-5-3 Body Checks (Continued)

10. **If using the RF Power Measurement Kit** refer to card **72** (1.5T Body Output)/ card **68.8** (1.0T Body Output) and note the Attenuation value listed on the calibration sticker affixed to the bottom, right of the card.
 - a. Measure the amplitude of the RF waveform from the scope face in divisions.
 - b. Mouse click on the **ToolBelt Icon** and then **[Utilities], [RF Calculator], [Start]**.
 - c. Use the RF Calculator program to determine the power output from the amplifier. Enter the actual reference and measured values in place of the sample values in the example below.

```

Quick RF Power Calculator
(A)mplitude from power
(P)ower from amplitude
(Q)uit
Enter selection: (A,P) [P] : P

Convert from Scope Amplitude to Power

Oscilloscope calibrated (with tool) to .: 4.00 (dBm)
with a reference amplitude of .....: 8.00 (divisions)
Enter measured amplitude (divisions)....: (0.0..8.00) [7.50] : 6 ←Enter value measured from
scope face here.
Measured power at scope is.....: 1.50 (dBm)

Refer to the RF Power Measurement Kit Quick Reference Card

Enter total component attenuation (dBm): (0.0..75.00) [68.56] : 59.49 ←Enter Attenuation value from the
calibration sticker as a POSITIVE number. Omit the negative sign.

Measured power at source is.....: 60.99 (dBm) ←Power in dBm at amplifier output
1256.38 (Watts) ←Power in Watts at amplifier output

Press ENTER to continue [ ] : <Enter>

Quick RF Power Calculator
(A)mplitude from power
(P)ower from amplitude
(Q)uit

Enter selection: (A,P) [P] : Q
    
```

- a. Note the amplifier output power calculated by the RF Calculator program. Continue with the Table instructions.

2-5-3 Body Checks (Continued)

11. **If using the wattmeter procedure:** Read the wattmeter display and use the formula below to calculate the body RF power. Note that the dummy load and cable loss factor was determined from the procedure in Appendix E of the Power Monitor Checks in the LX Service Methods. Record this calculated power and then continue with the Table instructions.

RF Power Measurement (in watts) Using Wattmeter And Formula:
Wattmeter reading (in watts) X dummy load and cable loss factor

12. **If using the oscilloscope procedure (NOT the RF Power Measurement Kit):** Read the peak voltage (V_{peak}) from the scope display and use the formula below or the [Power Calculator](#) Tool (located at E:\rf\power\pwrcalc.htm on the Service Methods CD-ROM) to calculate the body RF power. Note that the dummy load and cable loss factor was determined from the procedure in Appendix E of the Power Monitor Checks in the LX Service Methods and the scope correction factor was determined in Appendix A of this Manual. Record this calculated power and then continue with the Table instructions.

RF Power Measurement (in watts) Using Oscilloscope And Formula:
$\frac{\left(\frac{V_{\text{peak}}}{\text{scope correction factor}} \right)^2}{100} \times \text{dummy load and cable loss factor}$

13. When all measurements have been completed then reference the specified limits in the **Verify** column and record the PASS/FAIL status of the test.
14. Perform the steps in **Conclusion** column and then proceed to the next row and repeat the process again. Continue this until all the tests listed in the Table have been completed.

2-5-3 Body Checks (Continued)

TABLE 2-28
 BODY CHECKS (1.5T)

TEST	SCAN CONDITIONS	ADJUSTMENTS	VERIFY	CONCLUSION
BODY PEAK POWER <i>HIGH</i>	[Research Operations] [Display CVs] calmode = 2 trig = 7 aset = 120 [Accept] [Research Operations] [Download] [Manual Prescan].	Increase Transmit Gain (TG) until laptop or SSM LED indicates fault occurred on one of the monitors; measure and note Fault 1 power below. Fault 1 _____ Continue increasing TG until laptop or SSM LED indicates other monitor has faulted; measure and note Fault 2 power below. Fault 2 _____	Power (Fault 1, Fault 2) is within specifications: Min: 8793.9W, 69.44dBm Max: 11897.7W, 70.75dBm Nom: 10345.8W, 70.15dBm <input type="checkbox"/> Pass <input type="checkbox"/> Fail	Set TG to 0. [Done]. Place both Monitor A and B switches to RESET , then BYPASS. On laptop, press 'C' to continue.
BODY PEAK POWER <i>LOW</i>	[Research Operations] [Display CVs] aset = 30 [Accept] [Research Operations] [Download] [Manual Prescan].	Increase Transmit Gain (TG) until laptop or SSM LED indicates fault occurred on one of the monitors; measure and note Fault 1 power below. Fault 1 _____ Continue increasing TG until laptop or SSM LED indicates other monitor has faulted; measure and note Fault 2 power below. Fault 2 _____	Power (Fault 1, Fault 2) is within specifications: Min: 2198.5W or 63.42dBm Max: 2974.5W or 64.73dBm Nom: 2586.5W or 64.13dBm <input type="checkbox"/> Pass <input type="checkbox"/> Fail	Set TG to 0. [Done]. Place both Monitor A and B switches to RESET , then BYPASS. On laptop, press 'C' to continue.

2-5-3 Body Checks (Continued)

TABLE 2-28
BODY CHECKS (1.5T) (CONTINUED)

TEST	SCAN CONDITIONS	ADJUSTMENTS	VERIFY	CONCLUSION
BODY PULSE WIDTH(PW) HIGH (Min Limit)	<p>[Research Operations] [Display CVs]: aaset = 255 calmode = 1 pwset = 100 p1 = 4750 [Accept] [Research Operations] [Download] [Manual Prescan].</p>	<p>Increase TG (from 0) until power measures between: Minimum 2 kW (63.01 dBm) and Maximum 3 kW (64.77 dBm).</p>	<ul style="list-style-type: none"> • SENSE LEDs on SSM are ON, • BODY LED on RFI is ON, <p>FAULT LEDs (both OFF) (Note 1)</p> <p><input type="checkbox"/> Pass <input type="checkbox"/> Fail</p>	[Done].
BODY PW HIGH (Max Limit)	<p>[Research Operations] [Display CVs]: p1 = 5250 [Accept] [Research Operations] [Download] [Manual Prescan].</p>	Do not change TG.	<p>FAULT LEDs (both ON) (Note 1)</p> <p><input type="checkbox"/> Pass <input type="checkbox"/> Fail</p>	<p>[Done], Place both Monitor A and B switches to RESET, then BYPASS. On laptop, press 'C' to continue.</p>
BODY PW LOW (Min Limit)	<p>[Research Operations] [Display CVs]: p1 = 400 pwset=10 [Accept] [Research Operations] [Download] [Manual Prescan].</p>	Do not change TG.	<ul style="list-style-type: none"> • SENSE LEDs on SSM are ON, • BODY LED on RFI is ON, <p>FAULT LEDs (both OFF) (Note 1)</p> <p><input type="checkbox"/> Pass <input type="checkbox"/> Fail</p>	[Done].
BODY PW LOW (Max Limit)	<p>[Research Operations] [Display CVs]: p1 = 600 [Accept] [Research Operations] [Download] [Manual Prescan].</p>	Do not change TG.	<p>FAULT LEDs (both ON) (Note 1)</p> <p><input type="checkbox"/> Pass <input type="checkbox"/> Fail</p>	<p>[Done], Place both Monitor A and B switches to RESET, then BYPASS. On laptop, press 'C' to continue.</p>

Note 1

Allow at least 12 seconds after looping starts before checking status of FAULT LEDs.

2-5-3 Body Checks (Continued)

TABLE 2-28
 BODY CHECKS (1.5T) (CONTINUED)

TEST	SCAN CONDITIONS	ADJUSTMENTS	VERIFY	CONCLUSION
BODY DUTY CYCLE (DC) <i>HIGH</i> (Min Limit)	[Research Operations] [Display CVs]: t3=33333 TR_SLOP=0 calmode = 3 pwset = 255 dcset = 130 p3 = 3900 [Accept] [Research Operations] [Download] [Manual Prescan].	Do not change TG.	SENSE LEDs on SSM are ON, BODY LED on RFI is ON, FAULT LEDs (both OFF) (Note 1) <input type="checkbox"/> Pass <input type="checkbox"/> Fail	[Done].
BODY DC <i>HIGH</i> (Max Limit)	[Research Operations] [Display CVs]: p3 = 4767 [Accept] [Research Operations] [Download] [Manual Prescan].	Do not change TG.	FAULT LEDs (both ON) (Note 1) <input type="checkbox"/> Pass <input type="checkbox"/> Fail	[Done], Place both Monitor A and B switches to RESET , then BYPASS . On laptop, press 'C' to continue.
BODY DC <i>LOW</i> (Min Limit)	[Research Operations] [Display CVs]: p3 = 750 dcset = 25 [Accept] [Research Operations] [Download] [Manual Prescan].	Do not change TG.	SENSE LEDs on SSM are ON, BODY LED on RFI is ON, FAULT LEDs (both OFF) (Note 1) <input type="checkbox"/> Pass <input type="checkbox"/> Fail	[Done].
BODY DC <i>LOW</i> (Max Limit)	[Research Operations] [Display CVs]: p3 = 917 [Accept] [Research Operations] [Download] [Manual Prescan].	Do not change TG.	FAULT LEDs (both ON) (Note 1) <input type="checkbox"/> Pass <input type="checkbox"/> Fail	[Done], Place both Monitor A and B switches to RESET , then BYPASS . On laptop, press 'C' to continue.

2-5-3 Body Checks (Continued)

TABLE 2-29
BODY CHECKS (1.0T)

Test	Scan Conditions	Adjustments	Verify	Conclusion
BODY PEAK POWER <i>HIGH</i>	[Research Operations] [Display CVs] calmode = 2 trig = 7 aset = 110 [Accept] [Research Operations] [Download] [Manual Prescan]	Increase Transmit Gain (TG) until laptop or SSM LED indicates a fault occurred on one of the monitors; measure and record power or Vp as Fault 1 below. Fault 1 _____ Continue increasing TG until laptop or SSM LED indicates the other monitor has faulted; measure and record power or Vp as Fault 2 below. Fault 2 _____	Power or Vp (Fault 1, Fault 2) is within specifications: Min: _____ Vp or 4100W (66.127dBm) Nom: _____ Vp or 4300W (66.33dBm) Max: _____ Vp or 4500W (66.53dBm) <input type="checkbox"/> Pass <input type="checkbox"/> Fail	Set TG to 0. [Done] Place both Monitor A and B switches to RESET , then BYPASS . On laptop, press 'C' to continue.
BODY PEAK POWER <i>LOW</i>	[Research Operations] [Display CVs] aset = 30 [Accept] [Research Operations] [Download] [Manual Prescan]	Increase Transmit Gain (TG) until laptop or SSM LED indicates a fault occurred on one of the monitors; measure and record power or Vp as Fault 1 below. Fault 1 _____ Continue increasing TG until laptop or SSM LED indicates the other monitor has faulted; measure and record power or Vp as Fault 2 below. Fault 2 _____	Power or Vp (Fault 1, Fault 2) is within specifications: Min: _____ Vp or 1100W (60.41dBm) Nom: _____ Vp or 1200W (60.79dBm) Max: _____ Vp or 1300W (61.14dBm) <input type="checkbox"/> Pass <input type="checkbox"/> Fail	Set TG = 0. [Done] Place both Monitor A and B switches to RESET , then BYPASS . On laptop, press 'C' to continue.
BODY PULSE WIDTH (PW) <i>HIGH</i> (Min Limit)	[Research Operations] [Display CVs] aset = 255 calmode = 1 pwset = 35 p1 = 3912 [Accept] [Research Operations] [Download] [Manual Prescan]	Increase TG (from 0) until Vp or power measures between minimum _____ Vp or 500W (56.99 dBm) and _____ maximum _____ Vp or 700W (58.45 dBm).	SENSE LEDs on SSM are ON, <ul style="list-style-type: none"> BODY LED on RFI is ON, FAULT LEDs (both OFF) (Note 1) <input type="checkbox"/> Pass <input type="checkbox"/> Fail	[Done]

2-5-3 Body Checks (Continued)

TABLE 2-29
 BODY CHECKS (1.0T) (CONTINUED)

Test	Scan Conditions	Adjustments	Verify	Conclusion
BODY PW HIGH (Max Limit)	[Research Operations] [Display CVs] p1 = 4324 [Accept] [Research Operations] [Download] [Manual Prescan]	Do not change TG.	<ul style="list-style-type: none"> FAULT LEDs (both ON) (Note 1) (Note 2) <input type="checkbox"/> Pass <input type="checkbox"/> Fail	[Done] Place both Monitor A and B switches to RESET , then BYPASS . On laptop, press 'C' to continue.
BODY PW LOW (Min Limit)	[Research Operations] [Display CVs] p1 = 1076 pwset = 10 [Accept] [Research Operations] [Download] [Manual Prescan]	Do not change TG.	SENSE LEDs on SSM are ON, <ul style="list-style-type: none"> BODY LED on RFI is ON, FAULT LEDs (both OFF) (Note 1) <input type="checkbox"/> Pass <input type="checkbox"/> Fail	[Done]
BODY PW LOW (Max Limit)	[Research Operations] [Display CVs] p1 = 1276 [Accept] [Research Operations] [Download] [Manual Prescan]	Do not change TG.	<ul style="list-style-type: none"> FAULT LEDs (both ON) (Note 1) <input type="checkbox"/> Pass <input type="checkbox"/> Fail	[Done] Place both Monitor A and B switches to RESET , then BYPASS . On laptop, press 'C' to continue.

Note 1

Allow at least 12 seconds after looping starts before checking status of fault LEDs.

Note 2 (Applies to Body PW High [Max Limit] ONLY)

If Fault LEDs do not illuminate, slowly increase TG in 1 unit increments until both Fault LEDs do illuminate. Verify that, at this new TG, the power level does not exceed the maximum power level previously specified in the Body Pulse Width High (Min Limit) row under the Adjustments column.

2-5-4 Head Checks

Tests in this section allow the service engineer to selectively force head mode peak power, pulse width, and duty cycle beyond allowable limits.



PROPERTY DAMAGE! PREVENT COIL AND ASSOCIATED SWITCH DAMAGE, BY REMOVING ALL PHANTOMS AND HARDWARE (I.E., HEAD COIL, SURFACE COIL...) FROM THE MAGNET BORE.

1. Verify that the system is not scanning and that all coils have been removed from the magnet bore. See the two **DANGER** messages on this page.



PERSONAL INJURY! PREVENT POSSIBLE RF BURNS WHEN DISCONNECTING HELIAX CABLES FROM J3 OR J4 ON THE RFI BY VERIFYING THAT THE SYSTEM IS NOT MANUALLY PRESCANNING OR SCANNING. VERIFY THAT THE SCAN DESKTOP ICON DISPLAYS THE "IDLE" MESSAGE.



2. **If using the RF Power Measurement Kit** then refer to the RF Power Measurement Kit laminated card set.
 - a. Look in the upper, right corner of each card and find the card labeled **63** (1.5T Head Output) or find the card labeled **58** (1.0T Head RF Output).



The head RF output connection is no longer to the non-existent EFB unit, as the reference cards in some of the older kits show, but instead to the J3 output on the rear of the RFI.

- b. Configure the system as shown in the illustration on the card.
 - c. Confirm that the rotary attenuator is set to the correct position indicated on the card.
3. **If using the wattmeter or scope** (NOT the RF Power Measurement Kit) to measure power then refer to Appendix B (Alternate Equipment Setup) in the RF Power Monitor Checks Procedure in the LX Service Methods, RF for the proper system head configuration.
4. At operator workspace, select the scan desktop ICON in the desktop control panel, if you have not already done so.

2-5-4 Head Checks (continued)

5. At the operator workspace, prepare the system for a Head Power Monitor scan using the "Service Protocols" procedure in Table 2-30 below.

TABLE 2-30
SCAN PRESCRIPTION - HEAD PM CHECKS

Note: This is the alternate proprietary procedure available for GE use, and to sites with a valid Advanced Service Package Limited License. Refer to Appendix B for the non-proprietary protocol.

[New Pt]

Id: **geservice** <ENTER>
 Name: **pmc**
 Weight (Lb.): **300**
 Set Patient Protocols to **Service**.

At front enclosure:

Landmark in the Head area—remove all coils.
 press **LANDMARK**.
 press **MOVE TO SCAN**.

At Patient Protocols – select **other**.

In the protocol field, type **o.23.1**<ENTER> (o=Other, 23.1 =series) to load the head protocol

OR select [**o.23**] [**Series 1**] [**Accept**].

[**OK**] (if required).

[**Save Series**].

[**Prepare to Scan**].

[**Research Operations**].

[**Setup Params**]. Set **TG** to **50**. [**Done**].

[**Research Operations**].

[**Download**]

6. Refer to Table 2-31 for 1.5T Systems and Table 2-32 for 1.0T Systems. Note that the table consists of 5 columns (**Test**, **Scan Conditions**, **Adjustments**, **Verify**, **Conclusion**) and 10 individual rows of various head power tests.

Note

It may be advantageous at this point to print a hard copy of Table 2-31 or Table 2-32. This will provide a quick reference and also a place for making notations.

7. Start at the first **Test** row in Table 2-31 and Table 2-32. Under the **Scan Conditions** column highlight or type-in the CVs into the CV Name box and then enter the listed corresponding number into the Current Value box. Right mouse-click on the remaining items listed in the column.
8. Advance to the **Adjustments** column on the right and perform the directions listed in the column. Refer to the following steps for measuring the RF output power.
9. **If using the RF Power Measurement Kit** then refer to card **63** (1.5T Head Output)/ card **58** (1.0T Head RF Output) and note the Attenuation value listed on the calibration sticker affixed to the bottom, right of the card.
 - a. Measure the amplitude of the RF waveform from the scope face in divisions.
 - b. Mouse click on the **ToolBelt Icon** and then [**Utilities**], [**RF Calculator**], [**Start**].

2-5-4 Head Checks (continued)

- c. Use the RF Calculator program to determine the power output from the amplifier. Enter the actual reference and measured values in place of the sample values in the example below.

```

(Q)uick RF Calculator
  (R)F Calculator
    Enter selection: (Q,R) [Q] : Q
Quick RF Power Calculator
  (A)mplitude from power
  (P)ower from amplitude
  (Q)uit

    Enter selection: (A,P) [P] : P

    Convert from Scope Amplitude to Power

Oscilloscope calibrated (with tool) to .: 4.00 (dBm)
with a reference amplitude of .....: 8.00 (divisions)
Enter measured amplitude (divisions)....: (0.0..8.00) [7.50] : 6   ←Enter value measured from
scope face here.
Measured power at scope is.....: 1.50 (dBm)

Refer to the RF Power Measurement Kit Quick Reference Card

Enter total component attenuation (dBm): (0.0..75.00) [68.56] : 59.49 ←Enter Attenuation value from the
calibration sticker as a POSITIVE number. Omit the negative sign.

Measured power at source is.....: 60.99 (dBm) ←Power in dBm at amplifier output
                                   1256.38 (Watts) ←Power in Watts at amplifier output

Press ENTER to continue [ ] : <Enter>

Quick RF Power Calculator
  (A)mplitude from power
  (P)ower from amplitude
  (Q)uit

    Enter selection: (A,P) [P] : Q

```

- d. Note the amplifier output power calculated by the RF Calculator program. Continue with the Table instructions.

2-5-4 Head Checks (continued)

10. **If using the wattmeter procedure:** Read the wattmeter display and use the formula below to calculate the head RF power. Note that the cable loss factor was determined from the procedure in Appendix A. Record the calculated power and then continue with the Table instructions.

RF Power Measurement (in watts) Using Wattmeter And Formula:
$\text{Wattmeter reading (in watts)} \times \text{cable loss factor}$

11. **If using the oscilloscope procedure (NOT the RF Power Measurement Kit):** Read the peak voltage (V_{peak}) from the scope display and use the formula below or the [Power Calculator](#) Tool (located at E:\rf\power\pwrcalc.htm on the Service Methods CD-ROM) to calculate the head RF power. Note that the cable loss factor was determined from the procedure in Appendix A and the scope correction factor was determined in Appendix A. Record the calculated power and then continue with the Table instructions.

RF Power Measurement (in watts) Using Oscilloscope And Formula:
$\frac{\left(\frac{V_{\text{peak}}}{\text{scope correction factor}} \right)^2}{100} \times \text{dummy load and cable loss factor}$

12. When all measurements have been completed then reference the specified limits in the **Verify** column and record the PASS/FAIL status of the test.
13. Perform the steps in **Conclusion** column and then proceed to the next row and repeat the process again. Continue this until all the tests listed in the Table have been completed.

2-5-4 Head Checks (continued)

Table 2-31
HEAD CHECKS (1.5T) LX

Test	Scan Conditions	Adjustments	Verify	Conclusion
HEAD PEAK POWER <i>HIGH</i>	[Research Operations] [Display CVs] calmode = 2 trig = 7 aset = 120 [Accept] [Research Operations] [Download] [Manual Prescan]	Increase Transmit Gain (TG) until laptop or SSM LED indicates fault occurred on one of the monitors; measure and note Fault 1 power below. Fault 1 _____ Continue increasing TG until laptop or SSM LED indicates other monitor has faulted; measure and note Fault 2 power below. Fault 2 _____	Power (Fault 1, Fault 2) is within specifications: Min: 1318 W or 61.2 dBm Max: 1784 W or 62.5 dBm Nom: 1551 W or 61.9 dBm <input type="checkbox"/> Pass <input type="checkbox"/> Fail	Set TG to 0. [Done]. Place both Monitor A and B switches to RESET , then BYPASS . On laptop, press 'C' to continue.
HEAD PEAK POWER <i>LOW</i>	[Research Operations] [Display CVs] aset = 30 [Accept] [Research Operations] [Download] [Manual Prescan]	Increase Transmit Gain (TG) until laptop or SSM LED indicates fault occurred on one of the monitors; measure and note Fault 1 power below. Fault 1 _____ Continue increasing TG until laptop or SSM LED indicates other monitor has faulted; measure and note Fault 2 power below. Fault 2 _____	Power (Fault 1, Fault 2) is within specifications: Min: 330 W or 55.2 dBm Max: 446 W or 56.5 dBm Nom: 388 W or 55.9 dBm <input type="checkbox"/> Pass <input type="checkbox"/> Fail	Set TG to 0. [Done]. Place both Monitor A and B switches to RESET , then BYPASS . On laptop, press 'C' to continue.
HEAD PULSE WIDTH (PW) <i>HIGH</i> (min Limit)	[Research Operations] [Display CVs] calmode = 1 p1 = 4750 aset = 255 pwset = 100 [Accept] [Research Operations] [Download] [Manual Prescan]	Increase TG (from 0) until power measures between: Minimum 200W (53.0 dBm) and Maximum 300W (54.8 dBm).	SENSE LEDs on SSM are ON HEAD LED on RFI is ON FAULT LEDs (both OFF) (Note 1) <input type="checkbox"/> Pass <input type="checkbox"/> Fail	[Done].
HEAD PW <i>HIGH</i> (Max Limit)	[Research Operations] [Display CVs] p1 = 5250 [Accept] [Research Operations] [Download] [Manual Prescan]	Do not change TG.	FAULT LEDs (both ON) (Note 1) <input type="checkbox"/> Pass <input type="checkbox"/> Fail	[Done], Place both Monitor A and B switches to RESET , then BYPASS . On laptop, press 'C' to continue.

2-5-4 Head Checks (continued)

TABLE 2-31
HEAD CHECKS (1.5T) LX (CONTINUED)

Test	Scan Conditions	Adjustments	Verify	Conclusion
HEADPW LOW (Min Limit)	[Research Operations] [Display CVs] p1 = 400 pwset = 10 [Accept] [Research Operations] [Download] [Manual Prescan]	Do not change TG.	SENSE LEDs on SSM are ON HEAD LED on RFI is ON FAULT LEDs (both OFF) (Note 1) <input type="checkbox"/> Pass <input type="checkbox"/> Fail	[Done].
HEAD PW LOW (Max Limit)	[Research Operations] [Display CVs] p1 = 600 [Accept] [Research Operations] [Download] [Manual Prescan]	Do not change TG.	FAULT LEDs (both ON) (Note 1) <input type="checkbox"/> Pass <input type="checkbox"/> Fail	[Done], Place both Monitor A and B switches to RESET , then BYPASS . On laptop, press 'C' to continue.
HEAD DUTY CYCLE (DC) HIGH CYCLE (DC) (Min Limit)	[Research Operations] [Display CVs] t3 = 33333 TR_SLOP = 0 calmode = 3 p3 = 3900 pwset = 255 dcset = 130 [Accept] [Research Operations] [Download] [Manual Prescan]	Do not change TG.	SENSE LEDs on SSM are ON HEAD LED on RFI is ON FAULT LEDs (both OFF) (Note 1) <input type="checkbox"/> Pass <input type="checkbox"/> Fail	[Done].
HEAD DC High (Max limit)	[Research Operations] [Display CVs] p3 = 4767 [Accept] [Research Operations] [Download] [Manual Prescan]	Do not change TG.	FAULT LEDs (both ON) (Note 1) <input type="checkbox"/> Pass <input type="checkbox"/> Fail	[Done], Place both Monitor A and B switches to RESET , then BYPASS . On laptop, press 'C' to continue.
HEAD DC LOW (Min Limit)	[Research Operations] [Display CVs] p3 = 750 dcset = 25 [Accept] [Research Operations] [Download] [Manual Prescan]	Do not change TG.	SENSE LEDs on SSM are ON HEAD LED on RFI is ON FAULT LEDs (both OFF) (Note 1) <input type="checkbox"/> Pass <input type="checkbox"/> Fail	[Done].

2-5-4 Head Checks (continued)

TABLE 2-31
 HEAD CHECKS (1.5T) LX (CONTINUED)

Test	Scan Conditions	Adjustments	Verify	Conclusion
HEAD DC LOW (Max Limit)	[Research Operations] [Display CVs] p3 =917 [Accept] [Research Operations] [Download] [Manual Prescan]]	Do not change TG.	FAULT LEDs (both ON) (Note 1) <input type="checkbox"/> Pass <input type="checkbox"/> Fail	[Done], Place both Monitor A and B switches to RESET , then NORMAL . On laptop, press 'C' to continue.

2-5-4 Head Checks (continued)

TABLE 2-32
HEAD CHECKS (1.0T) LX

Test	Scan Conditions	Adjustments	Verify	Conclusion
HEAD PEAK POWER HIGH	[Research Operations] [Display CVs] calmode = 2 trig = 7 aset = 50 [Accept] [Research Operations] [Download] [Manual Prescan]	Increase Transmit Gain (TG) until laptop or SSM LED indicates a fault occurred on one of the monitors; measure and record power or Vp as Fault 1 below. Fault 1 _____ Continue increasing TG until laptop or SSM LED indicates the other monitor has faulted; measure and record power or Vp as Fault 2 below. Fault 2 _____	Power or Vp (Fault 1, Fault 2) is within specifications: Min: _____ Vp or 160 W (52 dBm) Nom: _____ Vp or 200 W (53 dBm) Max: _____ Vp or 240 W (53.8 dBm) <input type="checkbox"/> Pass <input type="checkbox"/> Fail	Set TG to 0. [Done]. Place both Monitor A and B switches to RESET , then BYPASS . On laptop, press 'C' to continue.
HEAD PEAK POWER LOW	[Research Operations] [Display CVs] aset = 30 [Accept] [Research Operations] [Download] [Manual Prescan]	Increase Transmit Gain (TG) until laptop or SSM LED indicates a fault occurred on one of the monitors; measure and record power or Vp as Fault 1 below. Fault 1 _____ Continue increasing TG until laptop or SSM LED indicates the other monitor has faulted; measure and record power or Vp as Fault 2 below. Fault 2 _____	Power or Vp (Fault 1, Fault 2) is within specifications: Min: _____ Vp or 100 W (50 dBm) Nom: _____ Vp or 117 W (50.7 dBm) Max: _____ Vp or 136 W (51.34 dBm) <input type="checkbox"/> Pass <input type="checkbox"/> Fail	Set TG to 0. [Done]. Place both Monitor A and B switches to RESET , then BYPASS . On laptop, press 'C' to continue.
HEAD PULSE WIDTH (PW) HIGH (Min Limit)	[Research Operations] [Display CVs] aset = 255 calmode = 1 pwset = 35 p1 = 3912 [Accept] [Research Operations] [Download] [Manual Prescan]	Increase TG (from 0) until Vp or power measures between minimum _____ Vp or 50W (46.9 dBm) and maximum _____ Vp or 70W (48.45 dBm).	<ul style="list-style-type: none"> • SENSE LEDs on SSM are ON <ul style="list-style-type: none"> • HEAD LED on RFI is ON • FAULT LEDs (both OFF) (Note 1) <input type="checkbox"/> Pass <input type="checkbox"/> Fail	[Done].
HEAD PW HIGH (Max Limit)	[Research Operations] [Display CVs] p1 = 4324 [Accept] [Research Operations] [Download] [Manual Prescan]	Do not change TG.	<ul style="list-style-type: none"> • FAULT LEDs (both ON) (Note 1) (Note 2) <input type="checkbox"/> Pass <input type="checkbox"/> Fail	[Done]. Place both Monitor A and B switches to RESET , then BYPASS . On laptop, press 'C' to continue.

2-5-4 Head Checks (continued)

TABLE 2-32
 HEAD CHECKS (1.0T) LX (CONTINUED)

Test	Scan Conditions	Adjustments	Verify	Conclusion
HEAD PW LOW (Min Limit)	[Research Operations] [Display CVs] p1 = 1076 pwset = 10 [Accept] [Research Operations] [Download] [Manual Prescan]	Do not change TG.	<ul style="list-style-type: none"> SENSE LEDs on SSM are ON <ul style="list-style-type: none"> HEAD LED on RFI is ON FAULT LEDs (both OFF) (Note 1) <input type="checkbox"/> Pass <input type="checkbox"/> Fail	[Done]
HEAD PW LOW (Max Limit)	[Research Operations] [Display CVs] p1 = 1276 [Accept] [Research Operations] [Download] [Manual Prescan]	Do not change TG.	<ul style="list-style-type: none"> FAULT LEDs (both ON) (Note 1) <input type="checkbox"/> Pass <input type="checkbox"/> Fail	[Done], Place both Monitor A and B switches to RESET , then BYPASS . On laptop, press 'C' to continue.
HEAD DUTY CYCLE (DC) High (Min Limit)	[Research Operations] [Display CVs] t3 = 33333 TR_SLOP = 0 calmode = 3 pwset = 255 dcset = 130 p3 = 3900 [Accept] [Research Operations] [Download] [Manual Prescan]	Do not change TG.	<ul style="list-style-type: none"> SENSE LEDs on SSM are ON <ul style="list-style-type: none"> HEAD LED on RFI is ON FAULT LEDs (both OFF) (Note 1) <input type="checkbox"/> Pass <input type="checkbox"/> Fail	[Done].
HEAD DC High (Max limit)	[Research Operations] [Display CVs] p3 = 4767 [Accept] [Research Operations] [Download] [Manual Prescan]	Do not change TG.	<ul style="list-style-type: none"> FAULT LEDs (both ON) (Note 1) <input type="checkbox"/> Pass <input type="checkbox"/> Fail	[Done], Place both Monitor A and B switches to RESET , then BYPASS . On laptop, press 'C' to continue.
HEAD DC LOW (Min Limit)	[Research Operations] [Display CVs] p3 = 750 dcset = 25 [Accept] [Research Operations] [Download] [Manual Prescan]	Do not change TG.	<ul style="list-style-type: none"> SENSE LEDs on SSM are ON <ul style="list-style-type: none"> HEAD LED on RFI is ON FAULT LEDs (both OFF) (Note 1) <input type="checkbox"/> Pass <input type="checkbox"/> Fail	[Done].

2-5-4 Head Checks (continued)

TABLE 2-32
 HEAD CHECKS (1.0T) LX (CONTINUED)

Test	Scan Conditions	Adjustments	Verify	Conclusion
HEAD DC LOW (Max Limit)	[Research Operations] [Display CVs] p3 =917 [Accept] [Research Operations] [Download] [Manual Prescan]	Do not change TG.	<ul style="list-style-type: none"> FAULT LEDs (both ON) (Note 1) <input type="checkbox"/> Pass <input type="checkbox"/> Fail 	<p>[Done], Place both Monitor A and B switches to RESET, then NORMAL. On laptop, press 'C' to continue.</p>

Note 1

Allow at least 12 seconds after looping starts before checking status of fault LEDs.

Note 2 (Applies to Head PW High [Max Limit] ONLY)

If Fault LEDs do not illuminate, slowly increase TG in 1 unit increments until both Fault LEDs do illuminate. Verify that, at this new TG, the power level does not exceed the maximum power level previously specified in the Head Pulse Width High (Min Limit) row under the Adjustments column.

2-5-5 Amplifier Shutdown Verification

Tests in this section verify that each power monitor is capable of shutting down the RF Amplifier independently of the other, and further verify both the logic and relay shutdowns for each channel. Setpoints are not checked in this section — this test is forcing a shutdown.

When one or both of the monitors is in bypass mode, the HV relay shutdown is disabled.

1. Enable power monitor A by placing the monitor A switch on the front panel of the SSM in the Normal (down) position.
2. At the operator workspace, prepare the system for a Amp Shutdown Verification scan using the "Service Protocols" procedure in Table 2-33 below.

Note

Verify that the Head Coil has been removed from the patient table before continuing.

Table 2-33

SCAN PRESCRIPTION - HIGH VOLTAGE RELAY SHUTDOWN — BODY MODE

Note: This is the alternate proprietary procedure available for GE use, and to sites with a valid Advanced Service Package Limited License.

[New Series]

At Patient Protocols – select **other**.

In the protocol field, type **o.23.3<ENTER>** (o=Other, 23.3 =series) to load the body protocol

OR select **[o.23] [Series 3] [Accept]**.

[OK] (if required).

[Save Series]

[Prepare to Scan].

[Research Operations].

[Setup Params]. Set **TG** to **0**. **[Done]**.

[Research Operations].

[Display CVs]. Highlight CV Name and enter the following:

- CV name: **trig <ENTER>, 1 <ENTER>**
- CV name: **aset <ENTER>, 120 <ENTER>**
- CV name: **calmode <ENTER>, 2 <ENTER>**
- CV name: **pwset <ENTER>, 255 <ENTER>**
- CV name: **dcset <ENTER>, 255 <ENTER>**
- CV name: **p1 <ENTER>, 3100 <ENTER>**
- CV name: **p3 <ENTER>, 2400 <ENTER>**

[Accept]

[Research Operations]

[Download].

Select **[Manual Prescan]**.

2-5-5 Amplifier Shutdown Verification (Continued)



The system error log will be checked in the next step for a power monitor fault error message. Make sure the error log Viewing Level selection is set to “ALL” before reading the error log. The error message may not otherwise be visible.

3. Increase TG until monitor A FAULT LED illuminates. Quickly verify the following:
 - The FAULT LED on for monitor A (resets automatically after 1 second).
 - Software Message Log - Software will log a power monitor fault in the message log.
 - Verify oscilloscope or Wattmeter (press FWD PEP then MAX) reads zero RF power.

Note

Do not perform any operations at the keyboard while In Place Error Recovery (IPER) is resetting the RF amplifier.

4. While waiting for the system to recover, place monitor B in normal mode by placing the monitor B switch on the front panel of the SSM in the Normal (down) position. Now both monitors A and B should be in normal mode.
5. After IPER has reset the RF amplifier (the “Please Press Start Scan Button” message appears in the upper left message window), decrease TG by 25 counts (2.5 dB) and then press START SCAN on the operator's console to initiate looping.
6. Increase TG until the FAULT LED for monitor A or B illuminates. Quickly verify the following:
 - FAULT LED on for monitor A or B (resets automatically after two seconds).
 - Software Message Log - Software will log a power monitor fault in the message log.
 - Verify oscilloscope or Wattmeter (press FWD PEP then MAX) reads zero RF power.

Note

Do not perform any operations at the keyboard while In Place Error Recovery (IPER) is resetting the RF amplifier.

7. While waiting for the system to recover, disable power monitor A by placing the monitor A switch on the front panel of the SSM in the Bypass position.
8. After IPER has reset the RF amplifier (the “Please Press Start Scan Button” message appears in the upper left message window), decrease TG by 25 counts (2.5 dB) and then press START SCAN on the operator's console to initiate looping.

2-5-5 Amplifier Shutdown Verification (Continued)

9. Increase TG until monitor B FAULT LED illuminates. Quickly verify the following:
 - FAULT LED on for monitor B (resets automatically after two seconds).
 - Software Message Log - Software will log a power monitor fault in the message log.
 - Verify oscilloscope or Wattmeter (press FWD PEP then MAX) reads zero RF power.

Note

Do not perform any operations at keyboard while In Place Error Recovery (IPER) is resetting the RF amplifier.

10. After IPER has reset the RF amplifier (the “Please Press Start Scan Button” message appears in the upper left message window), select **[Done]**.
11. In the Rx Manager, select **[End Exam]**, then **[Confirm]**.

2-5-6 System Restoration

1. Verify the system is not scanning and the scan desktop icon is displaying the “Idle” message.
2. Refer to Illustration 2-36. At the front of the SSM place the:
 - 2 (two) power MONITOR switches (A and B) to the bottom NORMAL position.
 - 3 (three) DRV FLT switches to the top EN (enable faults) position.

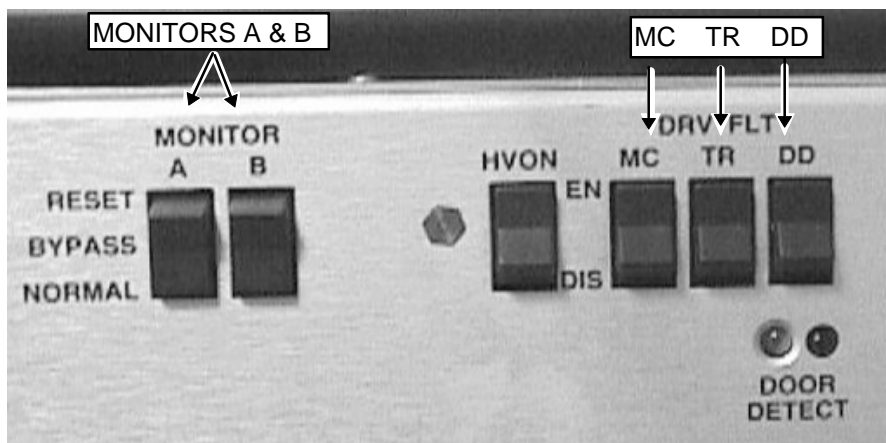

FRONT PANEL SWITCHES ENABLED
 ILLUSTRATION 2-36

3. Place DIP switches 4, 3, 2, and 1 of the Test Switches in the DOWN position or disconnect laptop computer from J46 on the rear of the SSM.

2-5-6 System Restoration (Continued)

Note

If using the Laptop perform the following steps to exit MONS1.EXE and return to Windows:

- A) Follow screen directions to return to DOS.
- B) At the DOS C:\CCLASS\RFTOOLS> prompt, type **EXIT<ENTER>**.

- 4. Ensure that the dummy load (all test equipment) is disconnected from the rear of the cabinet.
- 5. Ensure that the head and body Heliac cables are reconnected to the rear of the cabinet.
- 6. Complete one head scan satisfactorily.
- 7. Complete one body scan satisfactorily.
- 8. Replace the front and rear covers on the cabinet.

2-5-7 - Declaration Form Preparation

- 1. Prepare Direction 2212504, *Signa Release LX RF 1.0T/1.5T Cabinet Power Monitor Functional Test Declaration Form, Appendix A*. Refer to procedure for Data Sheet for Power Monitor Test Declaration Form.
- 2. File completed declaration form per current company policy.

2-6 Check RF Output Power

RF Output Power is checked using the TG value from SPT. (Refer to Appendix E, Section E-1-2, Viewing Results and Calibration File).

1. Verify there is a SPT file that was run within the last month. If not, run SPT now. (Refer to Appendix E, SYSTEM PERFORMANCE TEST).
2. Verify that the SPT SNR Test is within specification.
3. If the SNR Test is within specification, the RF Output Power is OK. If it is out of specification, determine if the TG value is causing the failure. If the TG value is causing the failure, schedule time to adjust the RF Output Power.