

# APPENDIX E - SYSTEM PERFORMANCE TEST

## TABLE OF CONTENTS

<u>SECTION</u>	<u>TITLE</u>	<u>PAGE</u>
E-1	SYSTEM PERFORMANCE TEST (SPT)—FULL TEST MODE.....	E-2
E-1-1	SPT Full Test Mode Procedure (Horizon 5.X) .....	E-2
E-1-2	Viewing Results and Calibration Files (Horizon 5.X) .....	E-12
E-1-3	SPT Full Test Mode Procedure (Release 8.X & 9.X).....	E-13
E-1-4	SPT Full Test Mode Procedure (Release 10.X) .....	E-22

## APPENDIX E - SYSTEM PERFORMANCE TEST

### E-1 SYSTEM PERFORMANCE TEST (SPT)—FULL TEST MODE

#### Description

This document relates to Signa Horizon 5.X, 8.X, 9.X & 10.X products, and covers the System Performance Test - Full Test Mode procedure.

#### Introduction

The System Performance Test (SPT) provides a means of quickly verifying that all critical parameters that affect image quality are within specification. Refer to CD ROM, *Direction 2124201-1, MR Signa 5.X Service Methods, Direction 21606231-1, MR Signa LX Service Methods* or *Direction 2333500-1, MR Signa 10.X Service Methods* for additional information.

#### E-1-1 SPT Full Test Mode Procedure (Horizon 5.X)

To set up and run SPT Full Test Mode, five general tasks must be completed:

- Cancel out of any previous exams.
- Touch [End Exam].
- Phantoms must be positioned and a landmark must be established.
- SPT must be invoked from the MR Tools Menu.
- Remove any patient positioning devices before placing the nesting plate, or other phantoms on the table. In particular, remove patient restraints or other devices that attach to the tracks along the edges of the cradle.

**E-1-1 SPT Full Test Mode Procedure (Horizon 5.X) (continued)**

**Phantom Positioning for SPT Full Test Mode (Horizon 5.X)**

The nesting plate, DQA-III phantom, LVShim phantom, body sphere with short loader, and the head coil are all required if all tests will be run.

1. Place the head coil on the patient table.
2. The DQA-III phantom will fit in the head coil only one way. Notice the small tabs on one end flange of the DQA-III phantom. These tabs go in the head coil first (see Illustration E-4). Place the DQA-III phantom in the head coil on the patient table (see Illustration E-5).

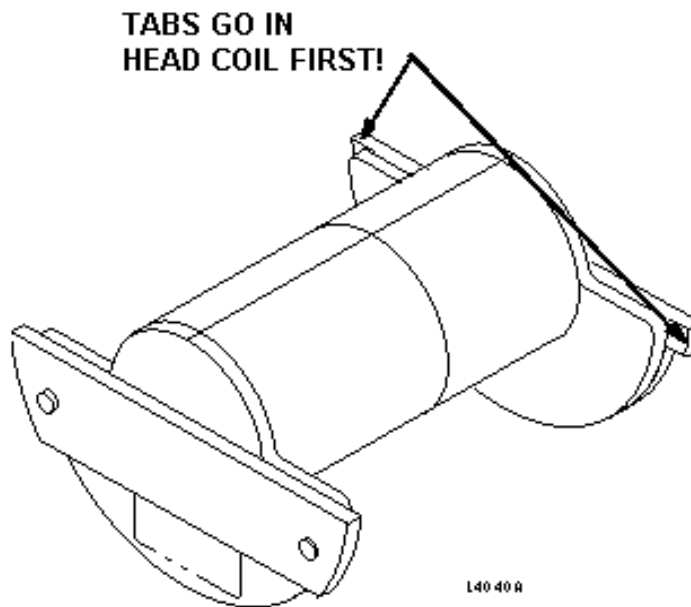

**DQA-III PHANTOM DETAILS**  
ILLUSTRATION E-4

**E-1-1 SPT Full Test Mode Procedure (Horizon 5.X) (continued)**

**Phantom Positioning for SPT Full Test Mode (Horizon 5.X) (continued)**

3. Pull the head coil all the way out to cover the DQA-III phantom (see Illustration E-5).

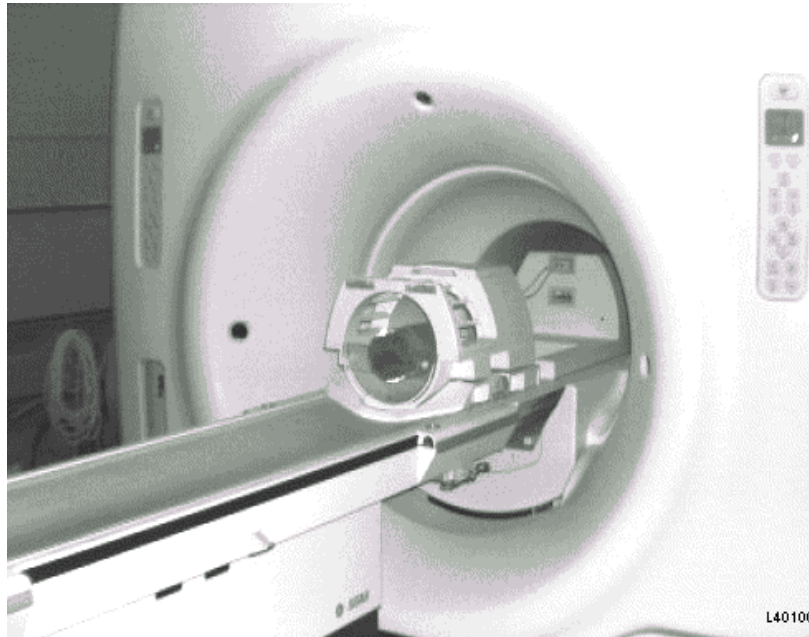

**HEAD COIL AND DQA-III PHANTOM CORRECTLY POSITIONED**  
ILLUSTRATION E-5

**E-1-1 SPT Full Test Mode Procedure (Horizon 5.X) (continued)**

**Phantom Positioning for SPT Full Test Mode (Horizon 5.X) (continued)**

4. Place the nesting plate on the patient table (see Illustration E-6).

If Shim test **will not be** run, go to Step 9.

If Shim test **will be** run, continue with Step 5a.

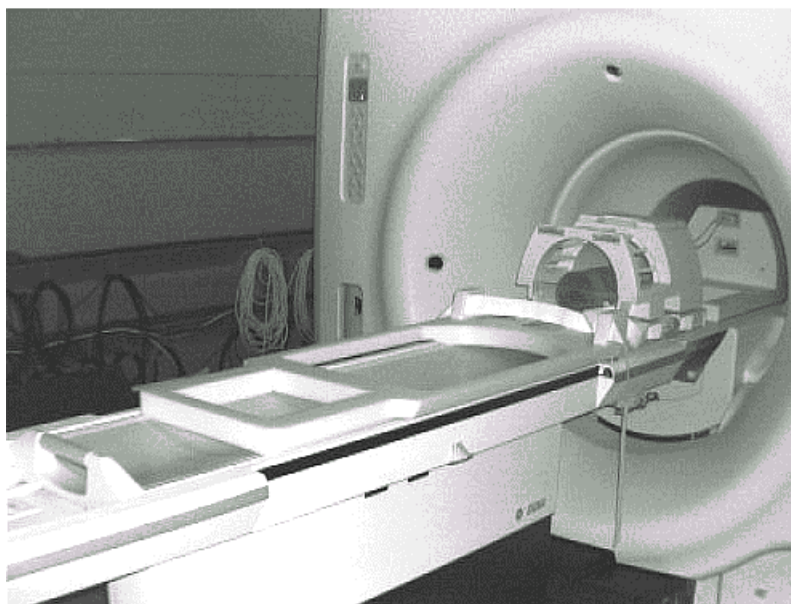

L4010D

**NESTING PLATE PROPERLY POSITIONED ON PATIENT TABLE**  
ILLUSTRATION E-6

**E-1-1 SPT Full Test Mode Procedure (Horizon 5.X) (continued)**

**Phantom Positioning for SPT Full Test Mode (Horizon 5.X) (continued)**

5a. Locate the LVShim phantom, and identify the three parts. (See Illustration E-7).

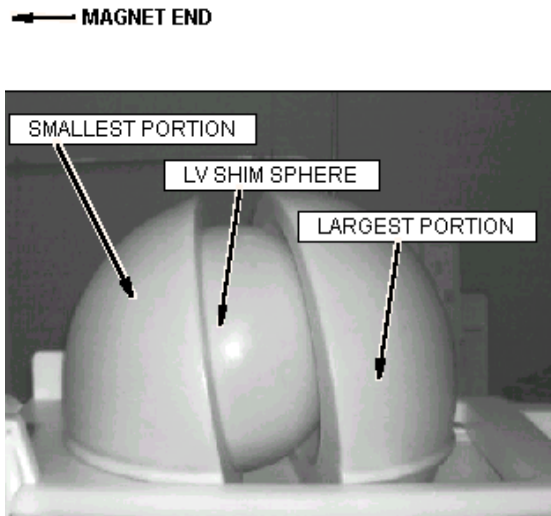

**LVSHIM PHANTOM COMPONENTS**  
ILLUSTRATION E-7

- 5b. Place the smallest portion of the LVShim phantom on the nesting plate.
6. Place the LVShim sphere in the smallest portion of the LVShim phantom.
7. Place the largest portion of the LVShim phantom on the combined LVShim phantom on the nesting plate.

**E-1-1 SPT Full Test Mode Procedure (Horizon 5.X) (continued)**

**Phantom Positioning for SPT Full Test Mode (Horizon 5.X) (continued)**

8. Place the strap for the LVShim phantom around the phantom and cinch it tightly, attaching the Velcro® hooks on the strap to the Velcro loops mounted on the outside of the largest portion of the LVShim phantom (see Illustration E-8).
9. Place the short loader with the body sphere inside on the nesting plate (see Illustration E-8). Note the position of the short loader. The label on the top of the short loader will indicate correct orientation.

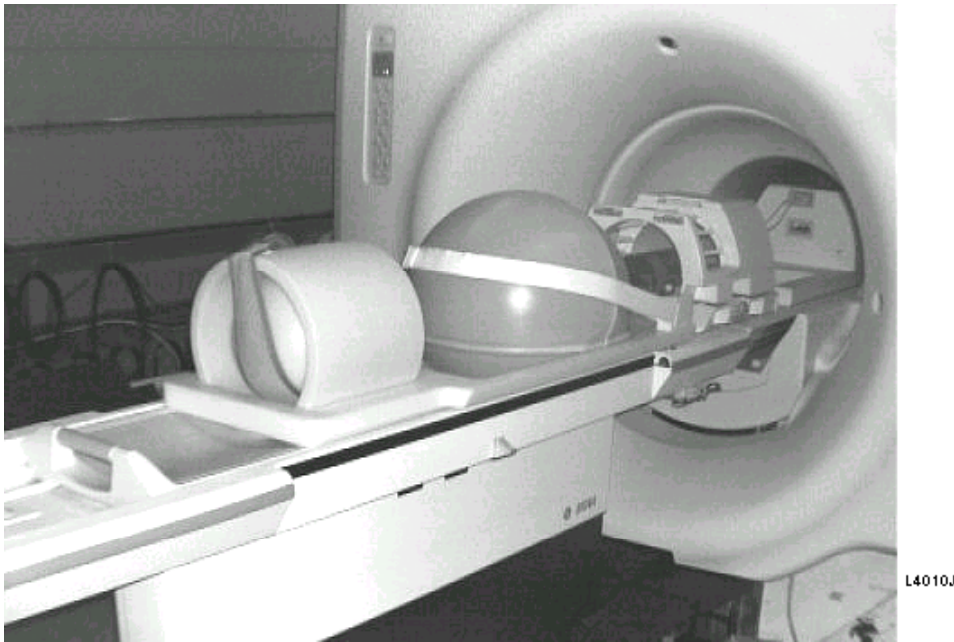

**SHORT BODY LOADER WITH BODY SPHERE POSITIONED ON THE NESTING PLATE**  
 ILLUSTRATION E-8

10. Landmark on the axial line on the DQA-III phantom in the head coil.
11. As a final positioning check, ensure the following:
  - Head Coil is all the way in position.
  - DQA-III is all the way in the head coil.
  - The nesting plate is up against the head coil Holder.

**E-1-1 SPT Full Test Mode Procedure (Horizon 5.X) (continued)**

**Invoking SPT Full Test Mode (Horizon 5.x)**



**Test functionality and system functionality may be adversely affected if the previous exam is not terminated. Touch [End Exam] to terminate any previous exam. It is not necessary to touch [New Exam] because SPT automatically enters the scan protocol when it is invoked via the MR Tools menu.**

1. Touch **[UTILITIES]**, [1], [2], [3].
2. Touch **[MR Tools]**.
3. Invoke SPT. Touch **[SPT Full Tst Mode]**. It is important to note that this test should always be used by the field engineer.

**Note**

SPT Head Quick Check should be used by the customer on a daily basis. If SPT Head Quick Check is used, trending will always be on, auto update to calibration parameters is always off, and the only choices there are for tests are Head Quick Check plus Stability, OR Head Quick Check and no Stability.

**E-1-1 SPT Full Test Mode Procedure (Horizon 5.X) (continued)**

**Invoking SPT Full Test Mode (Horizon 5.x) (continued)**

4. Select the appropriate tests to run. (See Table E-6.)

**Note**

Some messages displayed on the Touch Screen during SPT include: "14 images failed to reconstruct" following a FSE stability test, "looping stopped" after prescan, where SPT has set R1 to 6 and R2 to 14, or "autoprescan failed" before running the coherent noise test. These specific messages can be ignored.

TABLE E-6  
FE TEST SELECTION - SINGLE TEST

OUTPUT/PROMPTS	INPUTS/COMMENTS
<p>***** System Performance Test *****</p> <p>Please make sure the SPT phantoms are positioned correctly on the cradle, the DQA phantom has been positioned and landmarked in the head coil and you are at the top level scan screen.</p> <p>Press 's' or 'q' at any prompt to exit the tool</p> <p>Running the full set of tests takes about 1 hour and will thoroughly test the performance of your system. This is the recommended mode for baseline, PM and initial problem finding and is the default. The single test mode is meant to be used while troubleshooting. If possible, run the full set of tests at the end of your troubleshooting to verify system performance.</p> <p>Would you like to go into single test mode? (Y,N) [N]:</p> <p>Includes results in trend log? (Y, N) [N]:</p>	<p>y&lt;ENTER&gt;</p> <p>&lt;ENTER&gt;</p> <p><b>Note</b></p> <p><i>The default response is N if single-test mode is selected; otherwise, the default is Y.</i></p>

**E-1-1 SPT Full Test Mode Procedure (Horizon 5.X) (continued)**

**Invoking SPT Full Test Mode (Horizon 5.x) (continued)**

TABLE E-6 (continued)  
 FE TEST SELECTION - SINGLE TEST

OUTPUT/PROMPTS	INPUTS/COMMENTS
<pre> New Screen on Plasm ----- Tests available in SPT ===== HEAD:   1 Head Quick Check  OFF   2 Head SNR Only     OFF *3 Stability          OFF   4 Coherent Noise    OFF  BODY   5 Shim OFF   6 Eddy Current      OFF *7 Stability          OFF   8 Body SNR, System Gain  OFF   9 All tests    0 Accept Items with * will invoke a submenu Enter choice or q to exit (0..9) [0]: ----- New Screen on Plasm ----- Stability Tests in SPT ===== Fast Spin Echo:   1 All axes   2 Slice X, Readout Y      ON   3 Slice Y, Readout Z      OFF   4 Slice Z, Readout X      OFF  Gradient Recalled Echo:   5 All axes   6 Slice X, Readout Y      OFF   7 Slice Y, Readout Z      OFF   8 Slice Z, Readout X      OFF    9 All stability tests    0 Accept  Enter choice or q to exit (0..9) [0]:                     </pre>	<p>2&lt;ENTER&gt;</p> <p>&lt;ENTER&gt;</p>

**E-1-1 SPT Full Test Mode Procedure (Horizon 5.X) (continued)**

**Invoking SPT Full Test Mode (Horizon 5.x) (continued)**

TABLE E-6 (continued)  
 FE TEST SELECTION - SINGLE TEST

OUTPUT/PROMPTS	INPUTS/COMMENTS
----- New Screen on Plasm -----	
Would you like multiple passes? (Y,N) [Y]:	<ENTER>
Current time is hh:mm:ss. Estimated time for one pass is hh:mm:ss. Please enter stop time. (hh:mm:ss) [hh:mm:ss]:	<ENTER>
Selected stop time is too early for one pass. Current time is hh:mm:ss. Estimated time for one pass is hh:mm:ss. Please enter stop time. (hh:mm:ss) [hh:mm:ss]:	<ENTER>
Selected stop will permit nn passes. Estimated actual stop time is hh:mm:ss. Would you like to enter a new stop time? (Y/N) [N]:	<ENTER>
Are you ready to begin? (Y,N)[Y]:	<ENTER>
Generating output file header ===== Please enter two lines of comments (Max 70 characters/line) Press enter at the end of each line To leave a comment line empty, press Return  -----Max comment length-----  Comment Line 1: Type in you comments or just press <enter> for no comment. Comment Line 2: Type in your comments or jest press <enter> for no comment. -----	<ENTER>  <ENTER>
New Screen on Plasm -----	
Your test completed successfully The test results will be stored for performance trending and for local and remote use by service personnel.	
Would you like to run SPT again? (Y,N) [N]:	<ENTER>

**E-1-2 Viewing Results and Calibration Files (Horizon 5.x)**

After SPT has finished its analysis, the results are ready to be viewed via the Report Tool. Then, the specification files will have to be viewed to compare the results with the specifications.

1. Invoke the Report Tool. **[UTILITIES], [1], [2], [3], [MR Tools], [Report]**.
2. Select SPT from the list of tools to be viewed by typing **SPT<Enter>**.
3. Select the correct file name from the list that appears. Usually, you will want to view the results from the most recent scan. In this case, simply accept the default answer. (See Table E-7.)

TABLE E-7  
**SUMMARY REPORT FORMAT**

Z Isocenter	<pass/fail> see group 10	← invalidates all other tests if failing
Gradcal X	<pass/fail> see group 10	
Gradcal Y	<pass/fail> see group 10	
Gradcal Z	<pass/fail> see group 10	
Head Coil Gain	<pass/fail> see group 10	
Head SNR	<pass/fail> see group 10	
Head FSE Stab.	<pass/fail> see groups mm,nn,oo,etc.	← descending failure severity
Head GRE Stab.	<pass/fail> see groups mm,nn,oo,etc.	← descending failure severity
Shim	<pass/fail> see group 30	
Eddy Currents X	<pass/fail> see groups 40	
Eddy Currents Y	<pass/fail> see groups 41	
Eddy Currents Z	<pass/fail> see groups 42	
Body Coil Gain	<pass/fail> see group 70	
Body SNR	<pass/fail> see group 70	
Body FSE Stab.	<pass/fail> see groups mm,nn,oo,etc.	← descending failure severity
Body GRE Stab.	<pass/fail> see groups mm,nn,oo,etc.	← descending failure severity
Coherent Noise	<pass/fail> see groups xx through yy	← group numbers depend on magnet field strength

**E-1-3 SPT Full Test Mode Procedure (Release 8.X & 9.X)**

To set up and run SPT Full Test Mode, four general tasks must be completed:

- Cancel out of any previous exams. Click on **[End Exam]**.
- Phantoms must be positioned and a landmark must be established.
- SPT must be invoked from the MR Tools Menu.
- Remove any patient positioning devices **before** placing the nesting plate, or other phantoms on the table. In particular, remove patient restraints or other devices that attach to the tracks along the edges of the cradle.

**Phantom Positioning for SPT Full Test Mode**

The nesting plate, DQA-III phantom, LVShim phantom, body sphere with short loader, and the head coil are all required if all tests will be run.

1. Place the head coil on the patient table.
2. The DQA-III phantom fits in the head coil only one way. Notice the small tabs on one end flange of the DQA-III phantom. These tabs go in the head coil first (see Illustration E-9). Place the DQA-III phantom in the head coil on the patient table (see Illustration E-10).

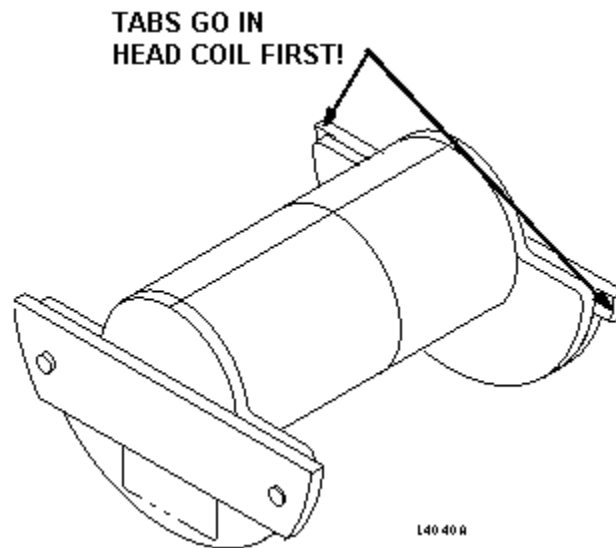

**DQA-III PHANTOM ORIENTATION**  
 ILLUSTRATION E-9

**E-1-3 SPT Full Test Mode Procedure (Release 8.X & 9.X) (continued)**

3. Pull the head coil all the way out to cover the DQA-III phantom see Illustration E-10.

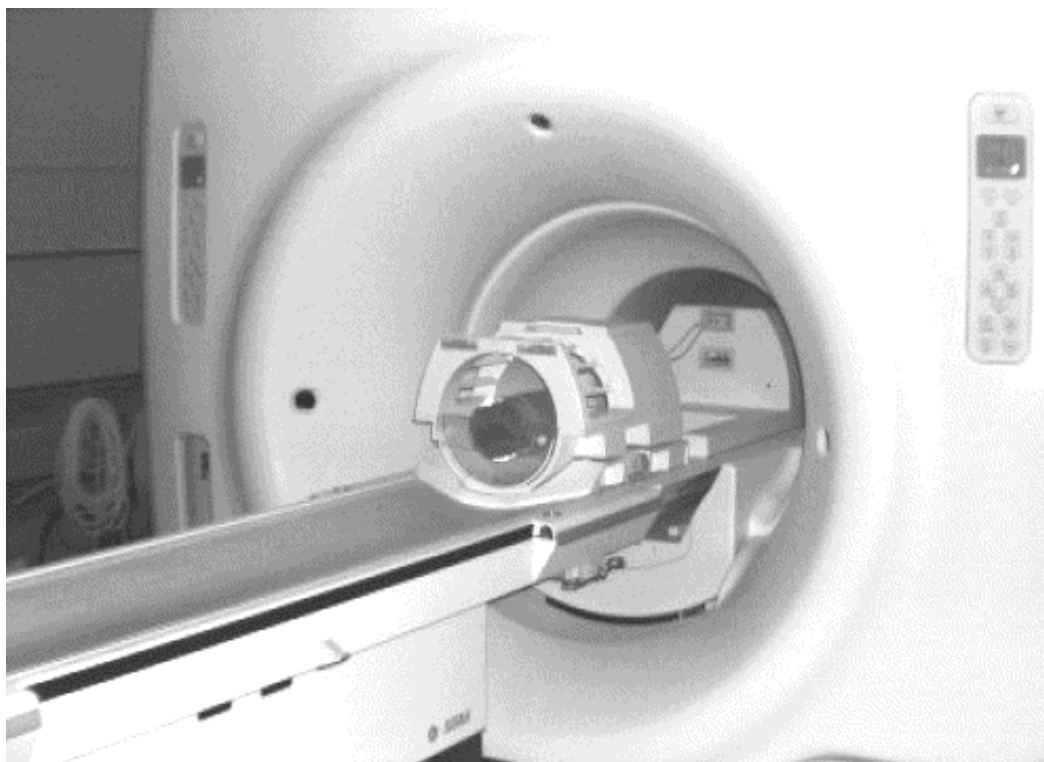

L4010C

**HEAD COIL AND DQA-III PHANTOM CORRECTLY POSITIONED  
ILLUSTRATION E-10**

**E-1-3 SPT Full Test Mode Procedure (Release 8.X & 9.X) (continued)**

4. Place the nesting plate on the patient table (see Illustration E-11).

If Shim test **will not be** run, go to step 6.

If Shim test **will be** run, continue with step 5.

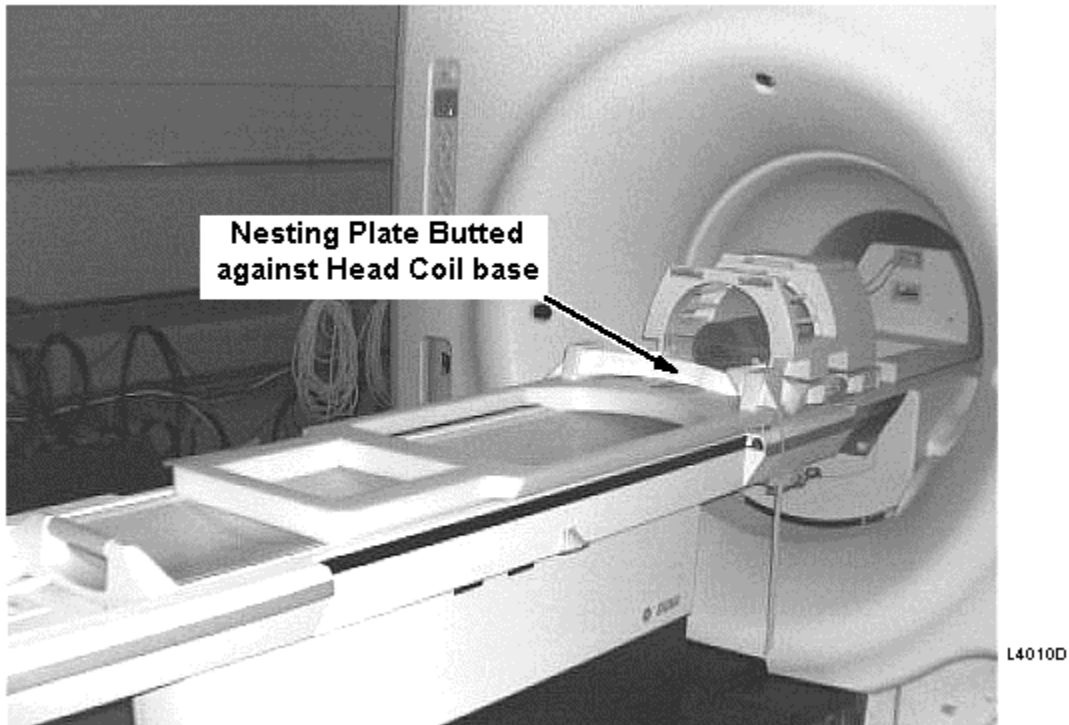

**NESTING PLATE PROPERLY POSITIONED ON PATIENT TABLE**  
ILLUSTRATION E-11

**E-1-3 SPT Full Test Mode Procedure (Release 8.X & 9.X) (continued)**

5. Locate the LVShim phantom, and identify the three parts. (See Illustration E-12).



Systems with the shorter CX or LCC Magnet and smaller CRM Body Coil (55cm) must run SPT Full Test mode without the LVshim phantom due to rear endbell interference. For these systems, leave the LVshim phantom off the nesting plate and de-select LVshim when running Full Test mode.

← MAGNET END

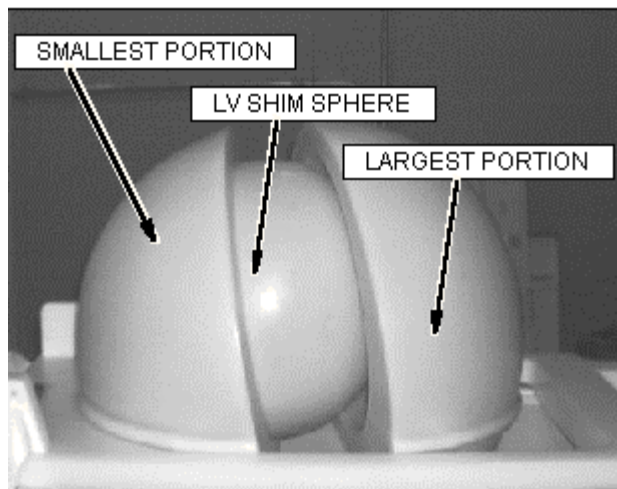

**LV SHIM PHANTOM COMPONENTS**  
 ILLUSTRATION E-12

- a. Place the smallest portion of the LVShim phantom on the nesting plate (part of nesting plate closes to Head Coil).
- b. Place the LVShim sphere in the smallest portion of the LVShim phantom.
- c. Place the largest portion of the LVShim phantom on the combined LVShim phantom on the nesting plate.
- d. Place the strap for the LVShim phantom around the phantom and cinch it tightly, attaching the Velcro® hooks on the strap around the phantom and attaching the Velcro loops mounted on the outside of the largest portion of the LVShim phantom. See Illustration E-13.

**E-1-3 SPT Full Test Mode Procedure (Release 8.X & 9.X) (continued)**

6. Place the short loader with the body sphere inside on the nesting plate (see Illustration E-13). Note the position of the short loader. The label on the top of the short loader indicates correct orientation.

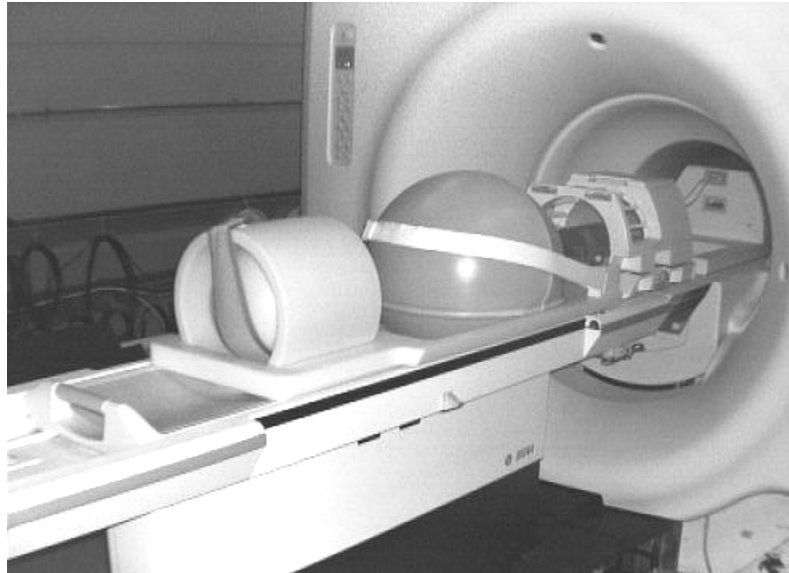

**SHORT BODY LOADER WITH BODY SPHERE POSITIONED ON NESTING PLATE**  
 ILLUSTRATION E-13

7. Landmark on the axial line of the DQA-III phantom in the head coil.
8. As a final positioning check, ensure that:
  - a. Head coil is all the way in position.
  - b. DQA-III is all the way in the head coil.
  - c. The nesting plate is up against the head coil holder.

**E-1-3 SPT Full Test Mode Procedure (Release 8.X & 9.X) (continued)****Invoking SPT Full Test Mode (Release 8.X & 9.X)**

**Test functionality and system functionality may be adversely affected if the previous exam is not terminated. Click on [End Exam] to terminate any previous exam. It is not necessary to click on [New Pt] as SPT automatically enters the scan protocol when it is invoked via the MR Tools menu.**

1. On the Service Desktop Manager, click **[Troubleshoot]** and select **SPT Full Test Menu**.
2. An SPT test menu appears in a window on the desktop (see Illustration E-14 for 8.X & 9.0 screen examples, see Illustration E-15 for 9.1 version screen)
  - a. **All tests:** Click **[No]** next to "Select all Tests". (*For systems with a CRM Body coil, select "Shimming" [Off] for Full Test Mode.*) **Selective tests:** Turn **[On]** tests you want to run.
  - b. For **TwinSpeed**, select the **GradMode(s) Whole, Zoom** or both that should be used while running the tests.
  - c. Select "Test Purpose:" reason, then enter any comments in the "Comments" field.
  - d. Click **[Start SPT]** to begin.

**Note**

For **TwinSpeed**, the tests must be repeated for each **GradMode**; in one session by selecting **Whole & Zoom**, and in separate sessions by selecting only one **GradMode**.



SPT MAIN SCREEN FOR 8.X & 9.X  
 ILLUSTRATION E-14

E-1-3 SPT Full Test Mode Procedure (Release 8.X & 9.X) (continued)



SPT MAIN SCREEN FOR 9.1  
 ILLUSTRATION E-15

**Viewing Results and Calibration Files**

After SPT has finished the analysis, the data files are viewed using the Report Manager. The specification files can also be viewed to compare the results against the specifications.

1. On the Service Desktop, select **[Utilities]**, then **[Report Manager]**.
2. The application is password protected. Enter the same password as used for the Service Methods CD-ROM.
3. Select "File", then "Open". A menu displays a list of files to choose from.

For additional information on Report Manager, select **[Software Utilities]** from the Service Methods CD-ROM, then **"Report Manager Tool"**.

**Viewing the Specification Files**

The specification files can be viewed using the **more** command, or via the **jot** editor.

**E-1-3 SPT Full Test Mode Procedure (Release 8.X & 9.X) (continued)**

**MORE Method**

1. Click on **[C Shell]** on the Service Desktop.
2. View the specification files. Type: **cd /usr/g/service/cclass/spt<Enter>**.
3. To view the specification file of interest, type **more filename<Enter>** using the filenames from Table E-8.

**JOT Method**

1. Click on **[C Shell]** on the Service Desktop. Type: **cd /usr/g/service/cclass/spt<Enter>**.
2. Type **jot <Enter>**. A jot window will appear on the desktop.
3. Select **Open** from the **File** pulldown menu. Select the **specification file** of interest from the browser list, and click on **[Accept]**. Refer to file list from Table E-8.
4. To exit JOT, select **Exit** from the **File** pulldown menu.

TABLE E-8  
 SPT SPECIFICATION FILES

PARAMETERS	FILE NAME
Calibration Specification File	cal.spt.
Eddy Current Specification File	eddy1.spt
Large Volume Shim Specification Files:	
GE S1 Magnets	ge_s1.spt
GE S2 Magnets	ge_s2.spt
GE S3 Magnets	ge_s3.spt
GE S-IV Magnets	ge_s4.spt
GE S-V Magnets	ge_s5.spt
GE S-X Magnets	ge_sx.spt
GE S-XC Magnets	ge_sxc.spt
Oxford Magnets	ox.spt
GE Cx Magnets	ge_cx.spt
Fast Recalled Echo (FSE) Stability Specification File	fsestb.spt
Gradient Recalled Echo (GRE) Stability Specification File	grestb.spt
Signal to Noise (SNR) File	snr.spt
Control Parameters File	spt_params.cfg

**E-1-4SPT Full Test Mode Procedure (Release 10.X)**

1. Click **[End Exam]** to cancel any previous exam. Then, click on **[New Pt]** so you can set a landmark.
2. Position the phantoms on the nesting plate. See Illustration E-16 & E-17. (Due to rear endbell interference, the LVshim phantom cannot be used with Full SPT Test Mode on systems with a CRM Body coil.)

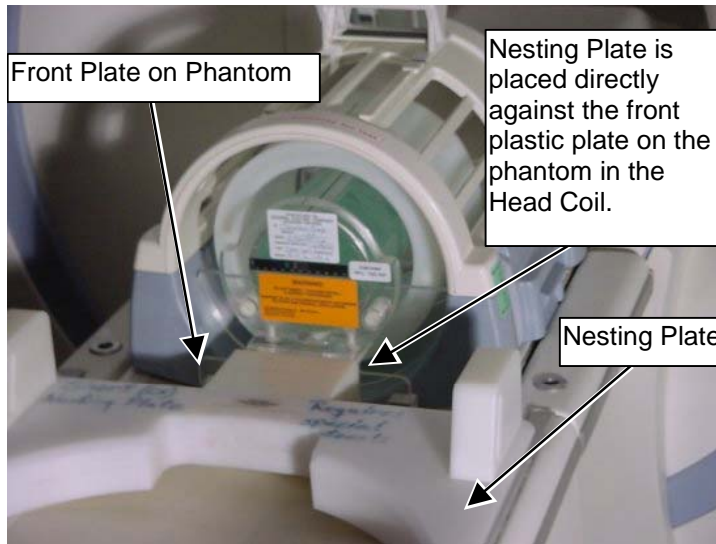

**PLACEMENT OF NESTING PLATE FOR SETUP OF SPT FULL TEST MODE**  
ILLUSTRATION E-16

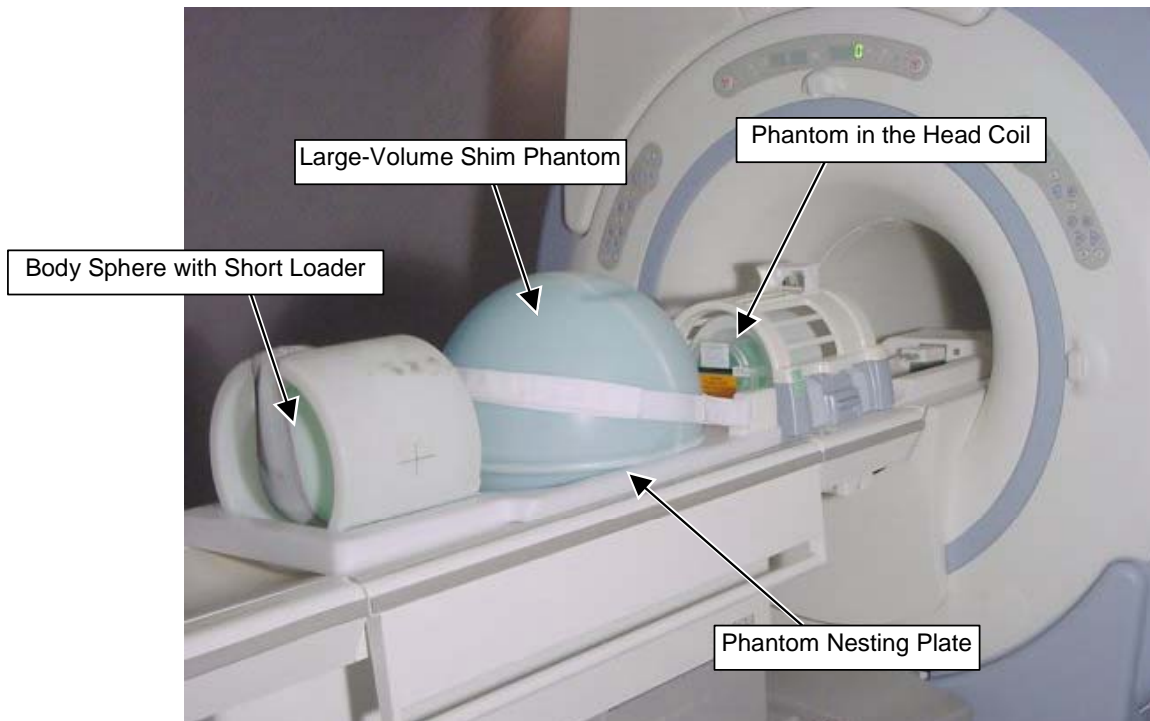

**SPT PHANTOM SET WITH NESTING PLATE**  
ILLUSTRATION E-17

**E-1-4SPT Full Test Mode Procedure (Release 10.X) (Continued)**

- 3. Landmark on the axial line of the phantom in the Head Coil.
- 4. To start the SPT Full Test tool, follow the steps on Illustration E-18, below:

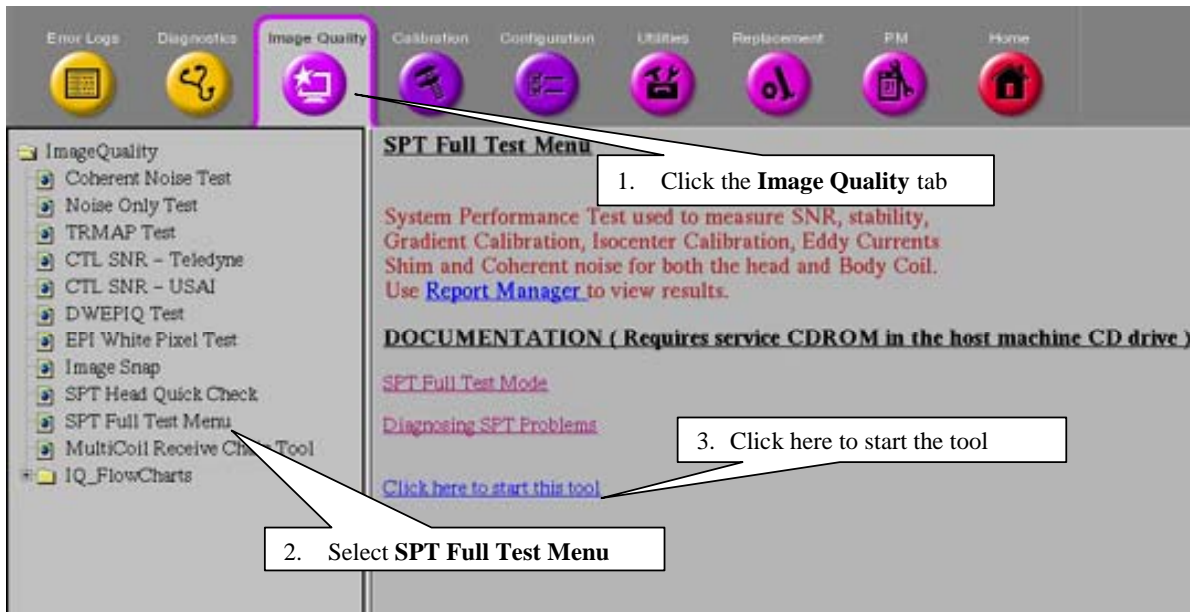

STARTING THE SPT TEST TOOL  
ILLUSTRATION E-18

- 5. The SPT Head Coil Selection screen appears. See Illustration E-19.



SELECT HEAD COIL FOR SPT SCREEN  
ILLUSTRATION E-19

**E-1-4SPT Full Test Mode Procedure (Release 10.X) (Continued)**

6. Click the button corresponding to the head coil currently in use:

- Old Head Coil and DQA Phantom, or
- New Head Coil and Phantom

7. Click the **Start** button.

The System Performance Test menu appears. See Illustration E-20.



SYSTEM PERFORMANCE TEST MENU  
 ILLUSTRATION E-20

- a. In the **Select All Tests?** field, click **[No]**.
- b. To select a reason for the test, click the button to the right of Test Purpose. Select a reason from the list. If desired, enter text in the Comments field.
- c. **For systems with a CRM Body Coil**, in the Body section, select Shimming **Off**.

**E-1-4SPT Full Test Mode Procedure (Release 10.X) (Continued)**

- d. Click the **On** button opposite the tests you want to run.
- e. For **TwinSpeed**, select the **GradMode(s)** to be used while running the tests.
- f. To select Multiple Passes of the test(s), select the **Multiple Passes** button, then enter the desired number of passes in the box.
- g. Click **[Start SPT]** to begin.

You may be prompted to make additional selections as the test begins.

Status messages will appear in the text box below the menu as the tests are run. Use the scroll bar on the right side of the box to move up or down through the messages.

- h. If desired, click the **WhatFailed** button. Output will appear in the text window of the System Performance Test screen, as shown in Illustration E-21.

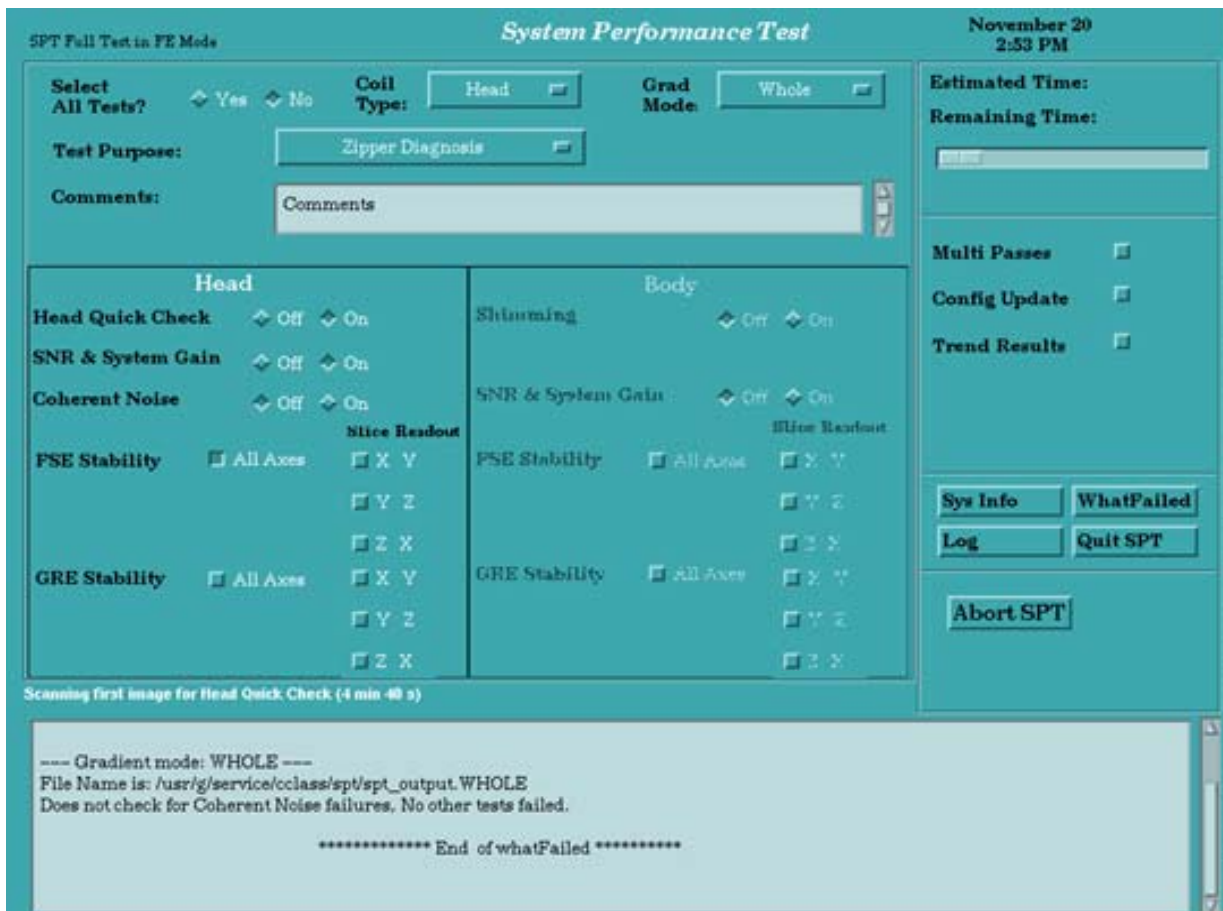

**WHATFAILED LISTING**  
 ILLUSTRATION E-21

**E-1-4SPT Full Test Mode Procedure (Release 10.X) (Continued)**

- i. If desired, click the **Sys Info** button to display system settings. See an example in Illustration E-22.

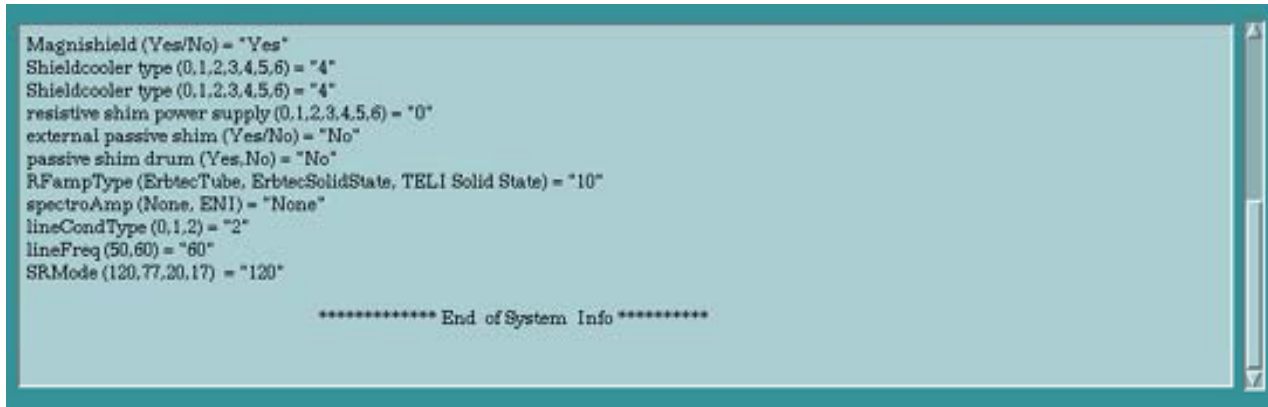

**EXAMPLE SYS INFO LISTING**  
ILLUSTRATION E-22

**Note**

This screen will be displayed until you quit SPT, so if you're in a troubleshooting mode, all you need to do is press the **[Start SPT]** button to go again.

- 6. To exit SPT, click the **[Quit SPT]** button. When prompted "WARNING: Quit SPT?", click **[Ok]**.
- 7. To view SPT results, follow the steps on Illustration E-23 to open the Report Manager.

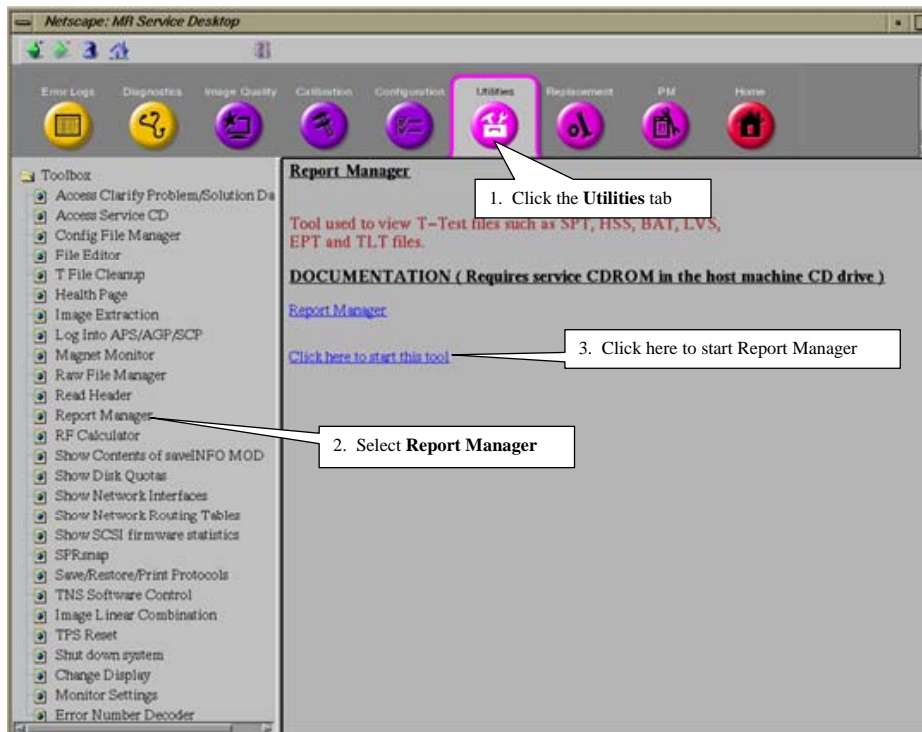

**ACCESSING REPORT MANAGER**  
ILLUSTRATION E-23

**E-1-4SPT Full Test Mode Procedure (Release 10.X) (Continued)**

- When prompted for a password, enter the same password used for the Service Methods CD-ROM. Press **<Enter>**. The File Open screen will display available reports. See Illustration E-24.

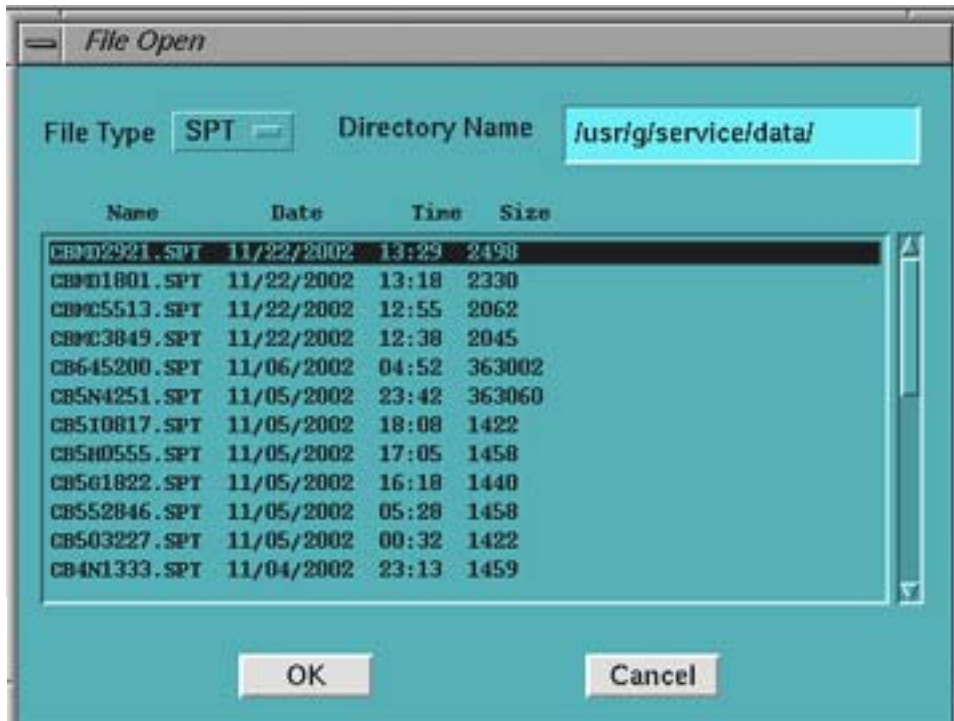

ACCESSING SPT REPORTS  
 ILLUSTRATION E-24

- To view an SPT report, first make sure the File Type is **SPT**. (If it is not, click the button following “File Type” and select **SPT** from the list.
- Select the report you’d like to view, then click **[OK]**.  
 Test results will appear in the Report Manager window. Use the **[Previous]** and **[Next]** buttons to view individual pages of the report.
- To print a report, select **File**, then **Print** from the Report Manager menu.
- To view another report, select **File**, then **Open**. Select the report from the list, then click **[OK]**.

**Note**

For additional information on Report Manager, select **[Software Utilities]** from the Service Methods CD-ROM, then **[Report Manager Tool]**.

**E-1-4SPT Full Test Mode Procedure (Release 10.X) (Continued)**

TABLE E-9  
**SPT SPECIFICATION FILES**

<b>PARAMETERS</b>	<b>FILE NAME</b>
Calibration Specification File	cal.spt.
Eddy Current Specification File	eddy1.spt
Large Volume Shim Specification Files:	
GE S1 Magnets	ge_s1.spt
GE S2 Magnets	ge_s2.spt
GE S3 Magnets	ge_s3.spt
GE S-IV Magnets	ge_s4.spt
GE S-V Magnets	ge_s5.spt
GE S-X Magnets	ge_sx.spt
GE S-XC Magnets	ge_sxc.spt
Oxford Magnets	ox.spt
GE Cx Magnets	ge_cx.spt
Fast Recalled Echo (FSE) Stability Specification File	fsestb.spt
Gradient Recalled Echo (GRE) Stability Specification File	grestb.spt
Signal to Noise (SNR) File	snr.spt
Control Parameters File	spt_params.cfg